

HDT BASE-X® MODEL 305 SHELTER

A Multi-Function Shelter for 12 -14 Personnel



The HDT Base-X Expedition Shelter system patented folding frame is recognized world-wide as the most advanced, lightweight, rapid-deploying tactical soft-walled shelter system on the market today. The unique patented folding frame design gives the system its superior strength and its rapid set-up and strike capabilities. This performance is achieved while keeping the system to a minimum weight and size when packed, making it more mobile and easier to embark. Missions that require speed and agility have relied on HDT's modular shelter systems design allowing for modular complexing to segment various activities. Our modular shelter systems allow rapid response to changing threats. HDT Base-X Shelters are user-friendly. The advanced frame guarantees quick setup and superior strength.

The Model 305 provides an interior clear span of 18' (5.49 m) wide. This shelter will house between 12-14 personnel.

It is also ideal for brigade and regiment size command and control, medical, communication, and logistics operations.

KEY FEATURES

- Lightweight, low-cube, man-portable
- Pre-installed floor, electrical wiring and HVAC plenum
- Meets or exceeds all US Military requirements
- No ancillary equipment required for setup or strike
 - Set up in minutes with only 4 personnel
- Operational in extreme weather conditions
- User friendly set up and tear down
- The Marine Corp standard



HDT BASE-X® MODEL 305 SHELTER

A Multi-Function Shelter for 12-14 Personnel



Shelter		Shelter with Stove Pipe Openings***		
HDT Part Number				
Olive Drab	603050D		60305SP0D	
Tan	60305TN		60305SPTN	
NSN				
Olive Drab	8340-01-533-1685		8340-01-545-5869	
Tan	8340-01-533-1686		8340-01-545-5884	
Interior Dimensions				
Floor Space	18' x 25'	5.49 x 4.57 m	18' x 25'	5.49 x 4.57 m
Area	450 ft ²	48.1 m ²	450 ft ²	48.1 m ²
Packed Dimensions				
Package 1*	63" x 38" x 28"	160 x 97 x 71 cm	63" x 38" x 28"	160 x 97 x 71 cm
Package 2**	63" x 30" x 20"	160 x 76 x 51 cm	63" x 30" x 20"	160 x 76 x 51 cm
Weight				
Package 1*	365 lbs	123 kg	365 lbs	123 kg
Package 2**	208 lbs	71 kg	208 lbs	71 kg
Total	573 lbs	194 kg	573 lbs	194 kg
Set-Up				
Time	12 minutes		12 minutes	
Personnel	4 each		4 each	

*Includes outer cover, frame, carry bag

**Includes carry bag, liner with pre-installed floor, electrical wiring, HVAC plenum, repair kit, and stake kit

***HDT offers an Expedition Shelter line with stove pipe openings. The outer fabric of the shelter contains a stovepipe vent, and the liner fabric in the interior of the shelter has a stovepipe clearance panel.

Products, product specifications and data are subject to change without notice to improve reliability, function, and/or design. Please contact Customer Service at 800.969.8527 for the most up-to-date product information.

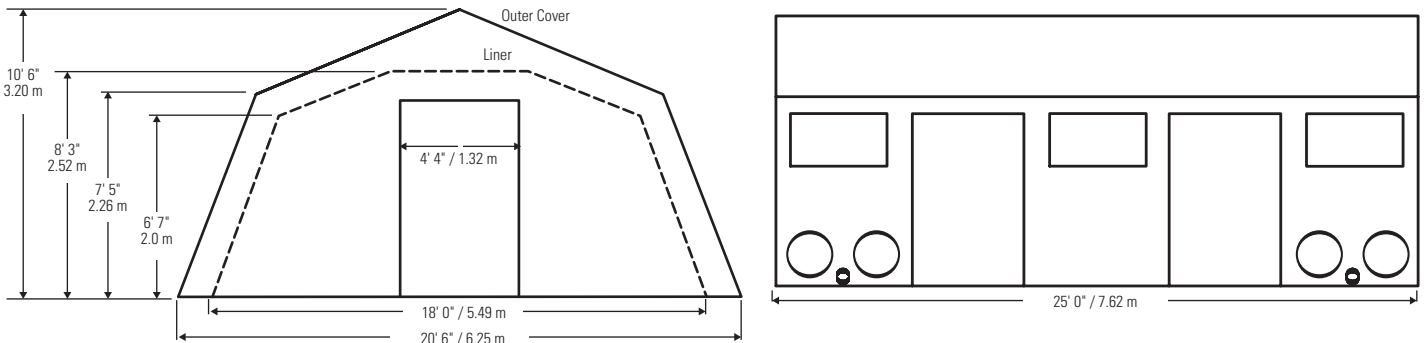

HDT Global

30500 Aurora Road Suite 100
 Solon, OH 44139 USA
 P 800.969.8527 / 216.HDT.6111
 sales@hdtglobal.com

NON-EXPORT CONTROLLED INFORMATION

Revision 7 03-23 01-01-01-0023