

HDT DRASH® TURF CART, 5 TON ECU HD

60,000 BTU/H (17.6 kW) Air Conditioning



HDT's DRASH 5 Ton ECU offers 60K BTU/H (17.6 kW) cooling capacity. The unit is equipped with eight supply ducts.

An HDT DRASH Turf Cart is available for use with the DRASH 5 Ton ECU. It is designed to easily transport DRASH ECUs weighing up to 2200 lbs (997.9 kg). This storage tray is capable of holding up to 120 lbs (54.4 kg) and has four tie down rings to safely secure the unit before moving. The turf cart color is available in tan or green. The towbar is equipped with two front wheel brakes. When towbar is released, the weight of it holds the brakes when ECU is in operation.

KEY FEATURES

- Eight (8) 4" supply ducts with storage bags, cap is available to cover the unused 4" ports
- Customized adaptor plenum (ECU outlet) is available to distribute cold air to suit various applications, see below
- 2,200 lbs (997.9 kg) cart capacity
- Includes handle with 3" diameter tow ring
- Front wheel steering
- Cart braking capability
- Low center of gravity with wide base, heavy duty cart
- Ease of ECU filter replacement, no interference with cart wheels
- Electric resistive heat is built-in, additional fuel fire heater is optional upon request
- Military standard ECU used in the TMSS Medium System



HDT DRASH® TURF CART, 5 TON ECU HD

60,000 BTU/H (17.6 kW) Air Conditioning



DRASH TURF CART WITH 5 TON ECU HD SPECIFICATIONS

Ordering information

Tan*

Part number	1016096
NSN	N/A
On GSA Contract	N/A

Refrigerant

R-407C

ECU capacity

Cooling	60,000 BTU/H
	17.6 kW

Air flow

	2,000 CFM at 1 iwg
	3398 m ³ /h at 0.25 kPa

Power

Requirements	208VAC / 3 Phase / 60 Hz
Maximum power draw	14 kW

Dimensions (L x W x H)

	105.6" x 67.5" x 67.9"
	268.2 x 171.5 x 172.5 cm

Weight

	1,470 lbs
	666.8 kg

* Other color available upon request
** 380-416VAC, 50Hz option is available

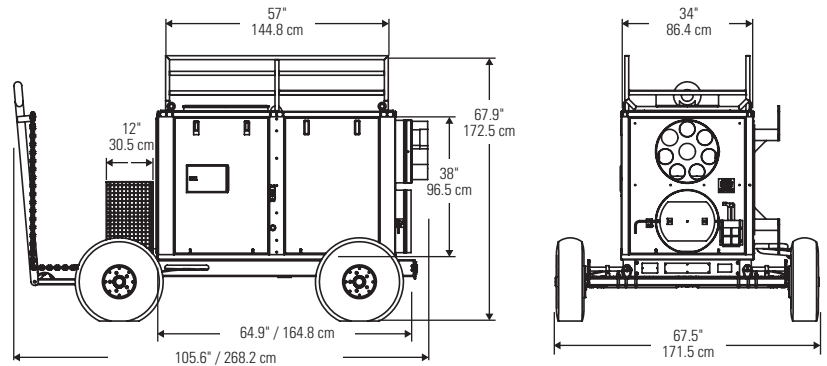

HDT Global

30500 Aurora Road Suite 100
Solon, OH 44139 USA
P 800.969.8527 / 540.887.4700
sales@hdtglobal.com

THIS COMMODITY, TECHNOLOGY OR SOFTWARE IS SUBJECT TO THE EXPORT ADMINISTRATION REGULATIONS (EAR), 15 CFR 730-774, OF THE UNITED STATES OF AMERICA.

Revision 1 05-16 01-05-02-0362