

OPERATOR'S, UNIT, AND INTERMEDIATE MAINTENANCE MANUAL

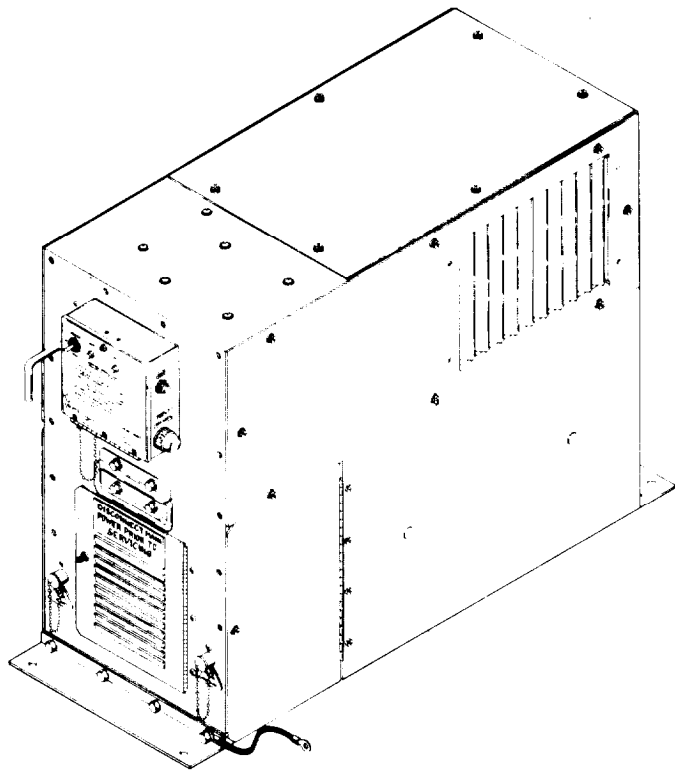

**HEATER, SPACE, MULTIFUEL
WITH BLOWER, 60,000 BTU/HR, 120 V
UH-68G
(4520-01-203-4410)**

TABLE OF CONTENTS i

OPERATING
INSTRUCTIONS 2-1

UNIT MAINTENANCE
INSTRUCTIONS 3-1

INTERMEDIATE
MAINTENANCE
INSTRUCTIONS 4-1

MAINTENANCE
ALLOCATION
CHART B-1

EXPENDABLE
SUPPLIES AND
MATERIALS LIST E-1

TORQUE LIMITS G-1

GLOSSARY

ALPHABETICAL INDEX

HEADQUARTERS, DEPARTMENT OF THE ARMY

4 NOVEMBER 1986

CHANGE

HEADQUARTERS
DEPARTMENT OF THE ARMY
WASHINGTON, D.C., 13 December 1989

No. 2

Operator's, Unit, and Intermediate Maintenance Manual

HEATER, SPACE, MULTIFUEL
WITH BLOWER, 60,000 BTU/HR, 120 V
MODEL UH-68G and UH-68G1
(4520-01-203-4410)
(4520-01-297-6803)

Approved for public release; distribution is unlimited.

TM 5-4520-253-13, 4 November 1986, is changed as follows:

1. Title is changed as shown above.
2. Remove and insert pages as indicated below. New or changed text material is indicated by a vertical bar in the margin. An illustration change is indicated by a miniature pointing hand.

Remove pages

i and ii
1-1 through 1-5/1-6

2-1 and 2-2
2-5 through 2-8

2-9 and 2-10
3-1 and 3-2
3-11 and 3-12
3-33 through 3-40

3-47 and 3-48
3-53 and 3-54
3-61 through 3-66
4-11 through 4-14

4-17 and 4-18

4-19 and 4-20
4-25 and 4-26

4-27 through 4-32

Index 1 and Index 2

Insert pages

i and ii
1-1 through 1-6
1-7 and 1-8
2-1 and 2-2
2-5 through 2-8
2-8.1 and 2-8.2
2-9 and 2-10
3-1 and 3-2
3-11 and 3-12
3-33 through 3-40
3-40.1/3-40.2
3-47 and 3-48
3-53 and 3-54
3-61 through 3-66
4-11 through 4-14
4-14.1/4-14.2
4-17 and 4-18
4-18.1/4-18.2
4-19 and 4-20
4-25 and 4-26
4-26.1 through 4-26.4
4-27 through 4-32
4-32.1/4-32.2
Index 1 and Index 2

3. Retain this sheet in front of manual for reference purposes.

By Order of the Secretary of the Army:

CARL E. VUONO
General United States Army
Chief of Staff

Official:

WILLIAM J. MEEHAN, II
Brigadier General United States Army
The Adjutant General

DISTRIBUTION:

To be distributed in accordance with DA Form 12-25A, Operator's, Unit, and Direct Support and General Support Maintenance requirements for Heater, Space (UH68G).

CHANGE-· }
No. 1 }

HEADQUARTERS
DEPARTMENT OF THE ARMY
WASHINGTON, D.C., 30 September 1988

Operator's, Unit, and Intermediate Maintenance Manual

HEATER, SPACE, MULTIFUEL WITH BLOWER
60,000 BTU/HR, 120 V, UH-68G
(4520-01-203-4410)

TM 5-4520-253-13, 4 November 1986, is changed as follows:

1. Remove and insert pages as indicated below. New or changed text material is indicated by a vertical bar in the margin. An illustration change is indicated by a miniature pointing hand.

Remove pages

i and ii
2-1 and 2-2

2-3 and 2-4
2-9 and 2-10
3-9 through 3-16
3-17 and 3-18
3-19 through 3-24

Insert pages

i and ii
2-1 and 2-2
2-2.1 through 2-2.5/2-2.6
2-3 and 2-4
2-9 and 2-10
3-9 through 3-16
3-17
3-24

2. Retain this sheet in front of manual for reference purposes.

By order of the Secretary of the Army:

CARL E. VUONO
General, United States Army
Chief of Staff

Official:

WILLIAM J. MEEHAN, II
Brigadier General, United States Army
The Adjutant General

DISTRIBUTION:

To be distributed in accordance with DA Form 12-25A, Operator's, Unit and Direct Support and General Support Maintenance requirements for Heater, Space, Multifuel, 60,000 BTU (UH-68F).

WARNING

DEATH OR SERIOUS INJURY

could occur if fuel is not handled carefully. Use in a well-ventilated area away from open flame, arcing equipment, ignition sources, heaters, or excessive heat. Engines must be turned off and cool before refueling. Use proper refueling procedures and equipment to avoid spillage. Do not run engines near open fuel containers. Do not use fuel as a cleaning solvent. **DO NOT SMOKE.**

EXPLOSION HAZARD

Do not operate heater if fuel leakage is detected.

CARBON MONOXIDE (EXHAUST GAS) CAN KILL YOU

Do not operate heater in enclosure unless exhaust gases are piped outside. Exhaust gases contain carbon monoxide, a colorless, odorless, deadly poisonous gas. Failure to provide proper elimination of the exhaust can cause severe illness or death.

SERIOUS INJURY

Do not connect power cable to 120 V ac, 50/60 Hz electrical source until power cable has been properly connected to power plug.

FIRE HAZARD

During operation, exhaust pipe becomes hot enough to cause combustion of wood or other flammable building materials. Provide adequate space and fireproof insulation between exhaust pipe and wall to prevent fire.

HEALTH AND SAFETY HAZARD

Dry cleaning solvent P-D-680 (safety or Stoddard's Solvent) is potentially dangerous. Avoid repeated and prolonged breathing of vapors and skin contact with the liquid. Do not use near open flame, arcing equipment, or other ignition sources. Always wear eye protection and protective clothing. Flash point of P-D-680 is 100° to 138° F (38° to 59°C).

WARNING

DEATH OR SERIOUS INJURY

could occur if compressed air is directed against the skin. Do not use compressed air for cleaning or drying unless the pressure is/has been reduced to 30 psi (207 kPa) or less. When working with compressed air always use chip guards, eye protection, and other personal protective equipment.

ELECTRIC SHOCK

Death or serious injury could occur if precautions are not taken when maintaining this equipment. Position HEATER-OFF-FAN switch to OFF, remove power cable plug from POWER RECEPTACLE, and ground capacitors C1 and C2 prior to gaining access to heater compartments, Terminals of capacitors are accessible at end cover of combustion blower. Always disconnect power cable before making continuity tests or before repairing heater. Always have another person standing by who is trained in electric shock first aid.

Remove electrical charge from ventilating air motor capacitor C3 by shorting out contacts using tool having insulated handle.

SEVERE BURNS

Allow sufficient time for heater to cool to room temperature before gaining access to heater compartments.

SEVERE BURNS

may result from touching surfaces of and near heat exchanger and exhaust system.

For artificial respiration, refer to FM 21-11.

Operator's, Unit, and Intermediate Maintenance Manual
HEATER, SPACE, MULTIFUEL WITH BLOWER
60,000 BTU/HR, 120 V, MODELS UH-68G AND UH-68G1
(4520-01-203-4410)
(4520-01-297-6803)

REPORTING ERRORS AND RECOMMENDING IMPROVEMENTS

You can help improve this manual. If you find any mistakes or if you know of a way to improve the procedures, please let us know. Mail your letter, DA Form 2028 (Recommended Changes to Publications and Blank Forms), or DA Form 2028-2 located in back of this manual direct to: Commander, U.S. Army Troop Support Command, Attention: AMSTR-MCTS, 4300 Goodfellow Boulevard, St. Louis, Missouri 63120-1798. A reply will be furnished to you.

			Page
CHAPTER	1	INTRODUCTION	1-1
Section	I	General Information	1-1
Section	II	Equipment Description and Data	1-2
Section	III	Technical Principles of Operation	1-5
CHAPTER	2	OPERATING INSTRUCTIONS	2-1
Section	I	Description and Use of Operator's Controls and Indicators	2-1
Section	II	Operator Preventive Maintenance Checks and Services	2-2.1
Section	III	Operation Under Usual Conditions	2-3
Section	IV	Operation Under Unusual Conditions	2-10
CHAPTER	3	UNIT MAINTENANCE INSTRUCTIONS	3-1
Section	I	Lubrication Instructions	3-1
Section	II	Repair Parts, Special Tools, TMDE, and Support Equipment	3-2
Section	III	Service Upon Receipt of Equipment	3-2
Section	IV	Unit Preventive Maintenance Checks and Services	3-10
Section	V	Troubleshooting	3-24
Section	VI	Maintenance Procedures	3-36
Section	VII	Preparation for Storage or Shipment	3-126
CHAPTER	4	INTERMEDIATE MAINTENANCE INSTRUCTIONS	4-1
Section	I	Troubleshooting	4-1
Section	II	Maintenance Procedures	4-11

	Page
APPENDIX A. REFERENCES	A-1
APPENDIX B. MAINTENANCE ALLOCATION CHART	B-1
APPENDIX C. COMPONENTS OF END ITEMS AND BASIC ISSUE ITEMS LIST	C-1
APPENDIX D. ADDITIONAL AUTHORIZATION LIST	D-1
APPENDIX E. EXPENDABLE SUPPLIES AND MATERIALS LIST	E-1
APPENDIX F. ILLUSTRATED LIST OF MANUFACTURED ITEMS	F-1
APPENDIX G. TORQUE LIMITS	G-1
	Glossary 1
	Index 1

LIST OF TABLES

Number	Title	Page
2-1	Controls and Indicators	2-1
2-2	Operator Preventive Maintenance Checks and Services	2-2.1
3-1	Additional Items	3-5
3-2	Unit preventive Maintenance Checks and Services	3-12
3-3	Unit Maintenance Troubleshooting	3-25
3-4	Plug Wiring Sequence	3-48
3-5	Control Box Harness Wires	3-53
3-6	Fabricated Control Box Harness Wires	3-54
3-7	Plug Wire Connections	3-126
4-1	Intermediate Maintenance Troubleshooting	4-2
4-2	Receptacle Wiring Sequence	4-22
4-2.1	Harness Receptacle Wiring Sequence	4-26.1
4-2.2	Harness Plug Wiring Sequence	4-26.2
4-3	Printed Circuit (PC) Board Testing	4-28

CHAPTER 1 INTRODUCTION

Section I. GENERAL INFORMATION

1-1. SCOPE

Type of Manual: Operator's, Unit, and Intermediate Maintenance Manual.

Model Number and Equipment Name: Model UH-68G and Model UH-68G1 Heater, Space, Multi-fuel With Blower, 60,000 Btu/Hour, 120 Volt, manufactured by Hunter Manufacturing Company, Cleveland, Ohio 44139.

Purpose of Equipment: Circulates heated air in enclosed spaces to maintain temperature within desired range. Designed to provide safe heating for both equipment and personnel.

1-2. MAINTENANCE FORMS AND RECORDS

Department of the Army forms and procedures used for equipment maintenance will be those prescribed by DA Pam 738-750, The Army Maintenance Management System (TAMMS).

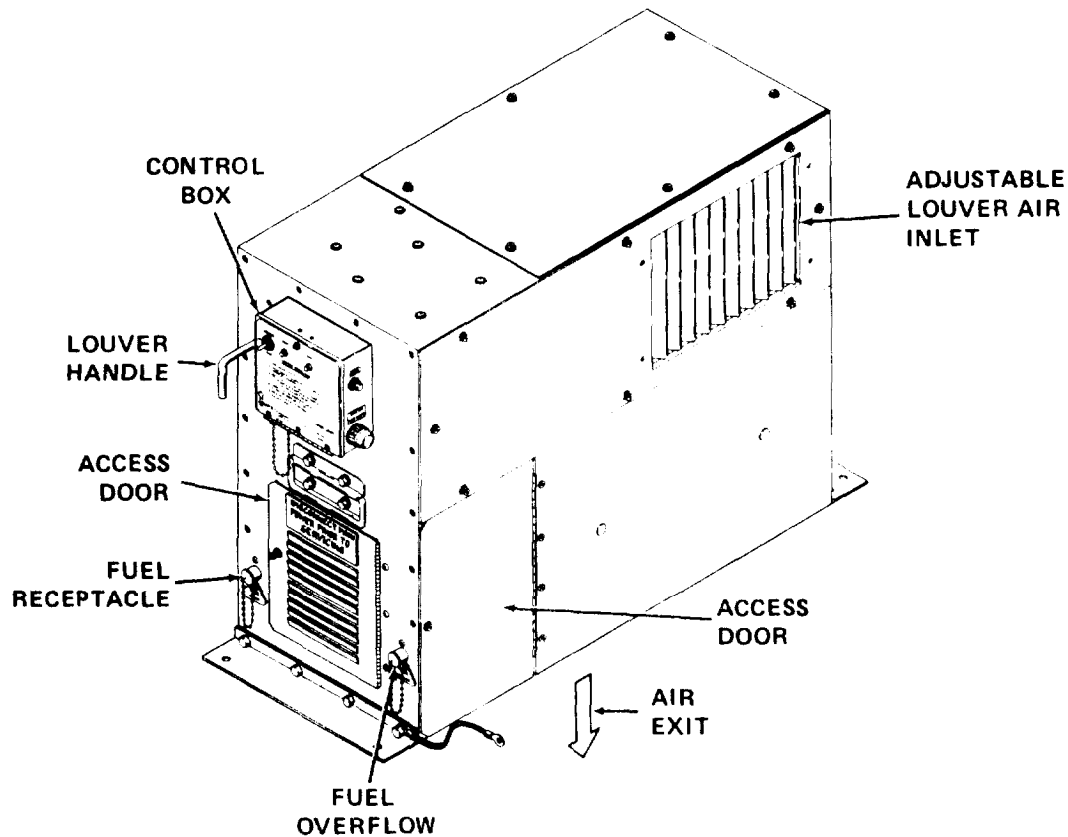

MODEL UH-68G AND UH-68G1 SPACE HEATER

1-3. REPORTING EQUIPMENT IMPROVEMENT RECOMMENDATIONS (EIR'S)

If your space heater needs improvement, let us know. Send us an EIR. You, the user, are the only one who can tell us what you don't like about your equipment. Let us know why you don't like the design or performance. Put it on an SF 368 (Quality Deficiency Report). Mail it to us at Commander, Headquarters, U.S. Army Troop Support Command, Attention: AMSTR-QX, 4300 Goodfellow Boulevard, St. Louis, Missouri 63120-1798. We will send you a reply.

1-4. DESTRUCTION OF ARMY MATERIEL TO PREVENT ENEMY USE

Command decisions, according to tactical situation, will determine when destruction of the space heater will be accomplished. A destruction plan will be prepared by the using organization, unless one has been prepared by higher authority. For general destruction procedures for this equipment, refer to TM 750-244-3, Procedures for Destruction of Equipment to Prevent Enemy Use.

1-5. PREPARATION FOR STORAGE OR SHIPMENT

Contact unit maintenance for preparation for storage or shipment. Refer to paragraphs 3-20 through 3-22.

1-6. NOMENCLATURE CROSS-REFERENCE LIST

For precise identification, simplified nomenclature has been established for clarity and is shown in the nomenclature cross-reference list.

NOMENCLATURE CROSS-REFERENCE LIST

This listing includes nomenclature cross-references used in this manual.

Common Name

Official Nomenclature

Space heater

Heater, Space, Multifuel With Blower, 60,000 BTU/HR,
120 V

Section II. EQUIPMENT DESCRIPTION AND DATA

1-7. PURPOSE OF HEATER

Model UH-68G and UH-68G1 space heaters burn gasoline or diesel fuel to generate heated air. Fuel is pumped from a remote source by an external fuel pump, forced through a spray nozzle, ignited, and burned in the combustion chamber of a heat exchanger. A fan blows air across the heat exchanger and into the space to be heated. Temperature is controlled by a room thermostat. Model UH-68G and UH-68G1 have the following applications:

- To heat rooms, maintenance buildings, storage facilities, shop, maintenance and communication vans.
- To supply forced fresh air ventilation without heating.

1-8. CAPABILITIES AND FEATURES

- Multifuel capability.
- Variable temperature range.
- Variable mounting attitude capability.
- Remote room thermostat control.
- Automatic shutdown to prevent overheating.

1-9. LOCATION AND DESCRIPTION OF MAJOR COMPONENTS

- (A) CONTROL BOX. Provides controls for operating heater or fan, reset buttons, and indicator lights.
- (B) HEATER CASE ASSEMBLY. Houses components of space heater.
- (C) PC BOARD CONTROL. Monitors and controls all functions of the space heater.
- (D) COMBUSTION BLOWER. Provides combustion air to burner of heat exchanger assembly.
- (E) IGNITION TRANSFORMER. Provides current for the igniter.
- (F) VENTILATING MOTOR ASSEMBLY. Blows fresh air across heat exchanger.
- (G) HEAT EXCHANGER. Fuel burns inside heat exchanger. Air flows over exterior of heat exchanger and is heated. Heated air is blown out of heat exchanger.
- (H) BURNER HEAD. Generates air-fuel mixture which burns inside heat exchanger.
- (I) CARBURETOR. Delivers controlled amount of fuel to burner head.

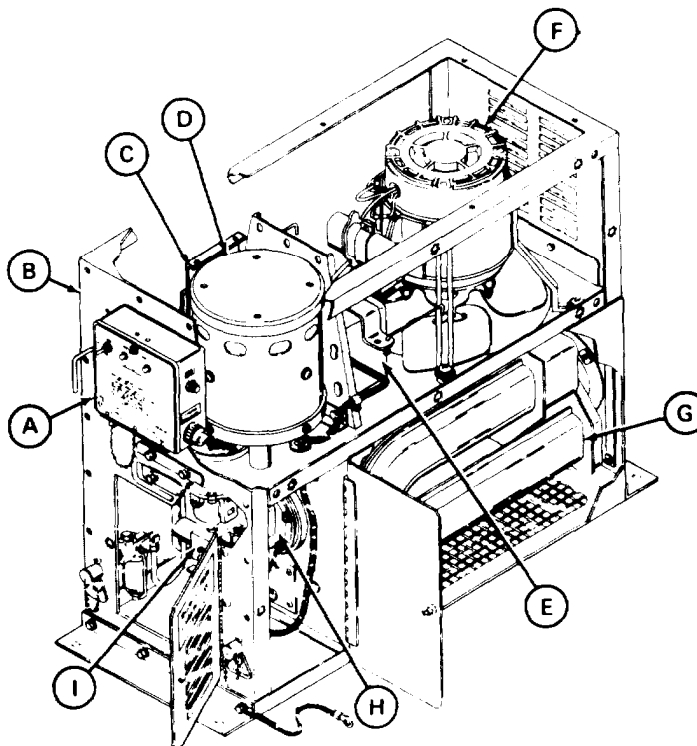

COMPONENTS OF UH-68G AND UH-68G1 SPACE HEATER

1-10. EQUIPMENT DATA

Manufacturer	Hunter Manufacturing Company
Model numbers	UH-68G and UH-68G1
Voltage	120 V ac
Cycles	50 to 60 Hz
Current draw	7.0 amp
Heating rate	60,000 Btu/hr
Air delivery rate	675 cfm (0.319 cu m/s) - 50 Hz 575 cfm (0.271 cu m/s) - 60 Hz
Fuel	Gasoline (up to 100-octane grade) Diesel fuel, VV-F-800, Class DF-1, DF-2, or DF-A
Overall dimensions and weight	
Height	21.187 in. (53.815 cm)
Width	10.875 in. (27.623 cm)
Depth	24.125 in. (61.278 cm)
Weight	120 lb (54.43 kg)

1-10.1 DIFFERENCES BETWEEN MODELS

Model UH-68G and UH-68G1 do not differ with regard to purpose, capabilities, features, or location and description of major components. Model UH-68G1 has a receptacle and plug connector added to the printed circuit (PC) board wiring harness. Model UH-68G has no connector in the harness. The receptacle and plug connector reduces the time and effort needed to replace the PC board assembly. If the PC board assembly must be replaced in a Model UH-68G space heater, a Model UH-68G1 printed circuit board assembly may be used. Electrical receptacles for power, external fuel pump, and room thermostat, located on the control box and heater case assembly, are soldered and potted connectors for the Model UH-68G. Electrical receptacles for the Model UH-68G1 are soldered and sealed with a grommet, ferrule, and endbell.

PC BOARD HARNESS CONNECTOR

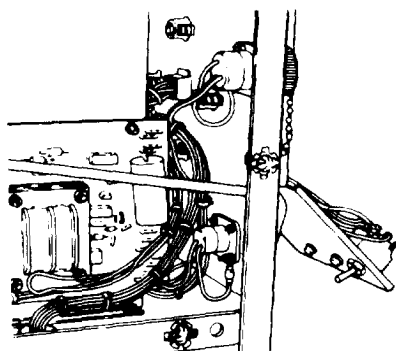

MODEL UH-68G

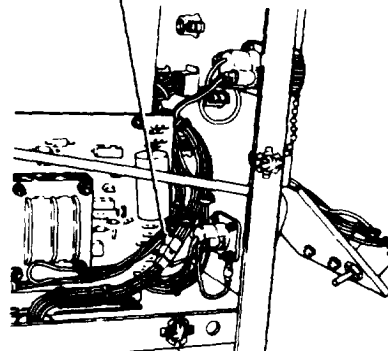

MODEL UH-68G1

Section III. TECHNICAL PRINCIPLES OF OPERATION

1-11. HEATER OPERATING PRINCIPLES

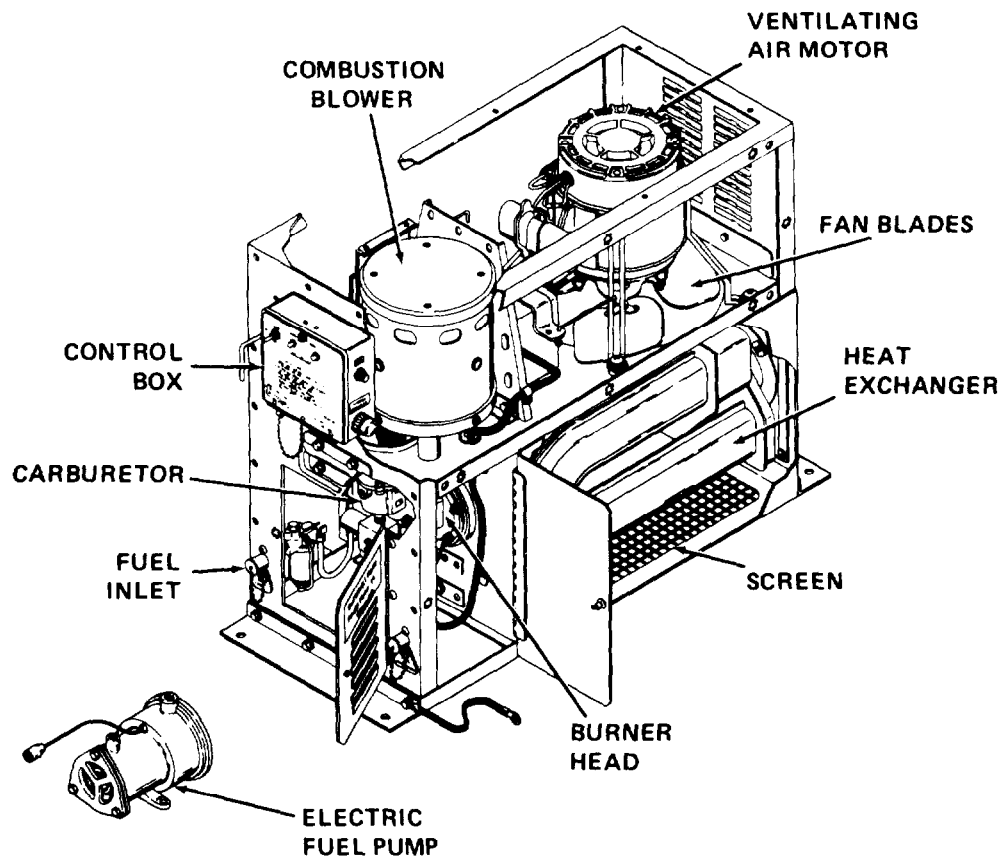

CONTROL BOX - contains controls and indicators. One control sets in motion a sequence of events which causes startup and operation of the heater.

CARBURETOR - controls flow of fuel to burner head.

COMBUSTION BLOWER - provides air to mix with fuel for combustion.

HEAT EXCHANGER - provides chamber where fuel is burned and heat generated. Combustion fumes are exhausted outside enclosure being heated.

VENTILATING AIR MOTOR - rotates fan blades and directs stream of air across heat exchanger and through screen. Continues operation after heater is turned off at control box until heater has cooled. Can be used to circulate unheated air.

ELECTRIC FUEL PUMP - not mounted on heater. Pumps fuel from remote supply to fuel inlet.

1-12. ELECTRICAL SEQUENCE OF OPERATION

FUNCTIONS. The heater has five functions: (1) START, (2) RUN, (3) PURGE, (4) FAULT, and (5) FAN.

START. With the heater connected to a 120 volt power source, potential is applied through circuit breaker CB1, the line side of HEATER-OFF-FAN switch S1, and flame switch FS1. Circuit breaker CB1 protects the heater circuitry from direct shorts or overloads.

RUN. When HEATER-OFF-FAN switch is turned to the HEAT position, three parallel circuits are closed. One circuit powers white HEAT light DS2. One circuit powers carburetor heater HR1 through carburetor thermostat-S2. This circuit is completed when the temperature is below 400° F. The third circuit sends power through connector J2 to the room thermostat. When the thermostat contacts are closed, calling for heat, power passes back through connector J2 to circuit breaker CB2. When pressed, circuit breaker CB2 allows current to flow to three circuits necessary for combustion: air, ignition, and fuel.

COMBUSTION. Combustion blower B2 supplies air needed for burning fuel. Combustion blower B2 is electrically suppressed by two feed-through capacitors C1 and C2. Combustion blower B2 also incorporates normally closed thermal overload switch S5.

IGNITION. Ignition transformer T1 supplies the spark necessary to ignite the fuel for burning. Transformer T1 increases the applied 120 volts to 6000 volts across igniter plug E1, which is much like an automobile spark plug.

FUEL. The power from circuit breaker CB2 passes through two overheat switches S3 and S4 before going to stepdown transformer T2 which decreases 120 volts to 24 volts. The 24 volts alternating current is converted to 24 volts direct current by bridge rectifier CR1. The 24 volts direct current powers fuel solenoid L1 and fuel pump L2, used to supply fuel for combustion.

HEAT. If all three items (spark, fuel, and combustion air) are present in their proper amounts, combustion takes place in the heat exchanger, producing heat. If heat is sensed by flame switch FS1 within a preset time after main HEATER-OFF-FAN switch S1 is closed, the heater will continue to operate and ventilating air motor B1 will operate.

FLAME SWITCH. Flame switch (FS1) is a normally open (NO), normally closed (NC) thermal switch. The NC contacts complete the circuit for the time delay through the windings of the vent motor (B1). When the heat exchanger reaches approximately 125°F the FS1 contacts reverse. The FS1 reversing action opens the circuit to the time delay and activates the B1 motor to circulate warm air.

PURGE. When the contacts of room thermostat S7 are opened or HEATER-OFF-FAN switch S1 is turned to the OFF position when the heater is hot, the unit will go into its purge cycle. Potential is applied through circuit breaker CB1 to the normally open contacts of flame switch FS1, now closed because of the hot heat exchanger, to ventilating air motor B1. Ventilating air motor B1 will stay in the circuit until the heat exchanger cools enough to allow the contacts of flame switch FS1 to open.

FAN. When HEATER-OFF-FAN switch S1 is placed in the FAN position, ventilating air motor B1 will be started with the aid of start capacitor C3. Capacitor C3 is disconnected by the RPM increase of ventilating air motor B1. Ventilating air motor B1 is protected by overload switch S6, connected to the windings.

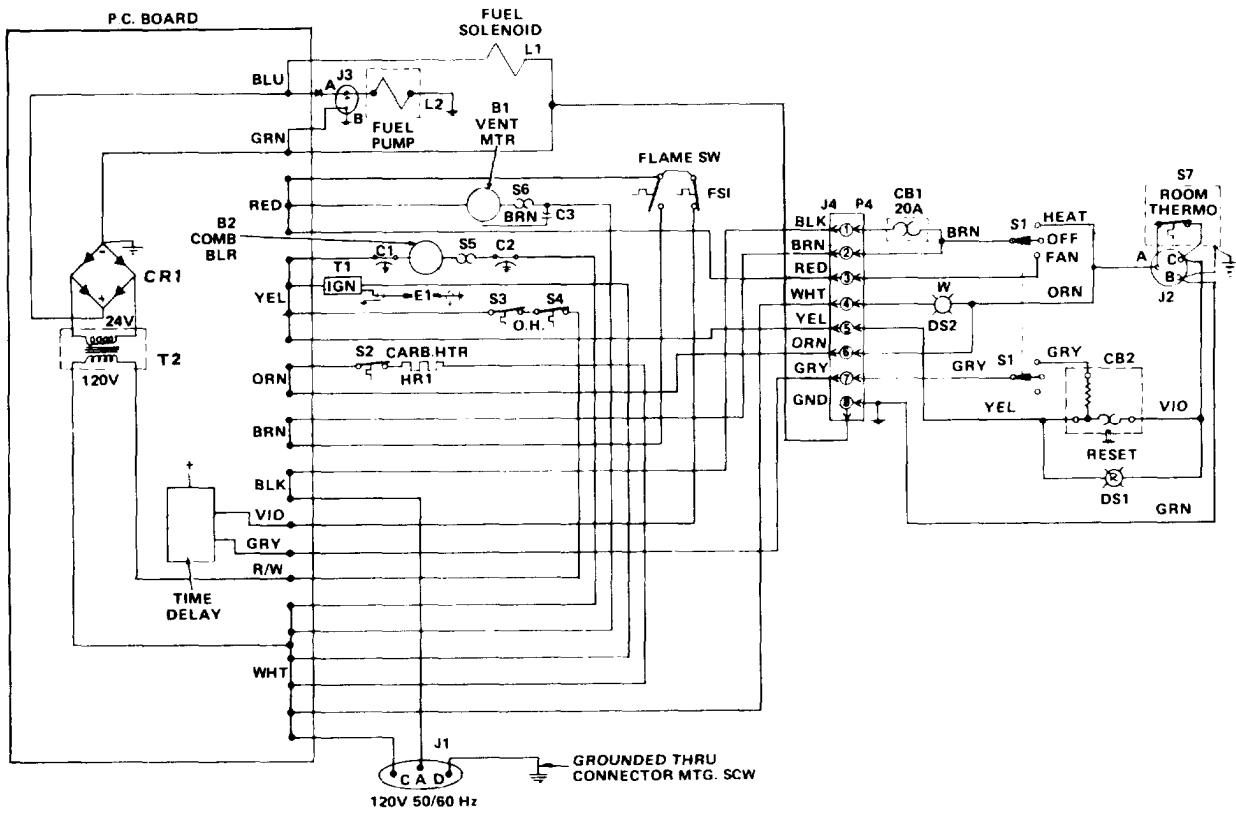

MODEL UH-68G

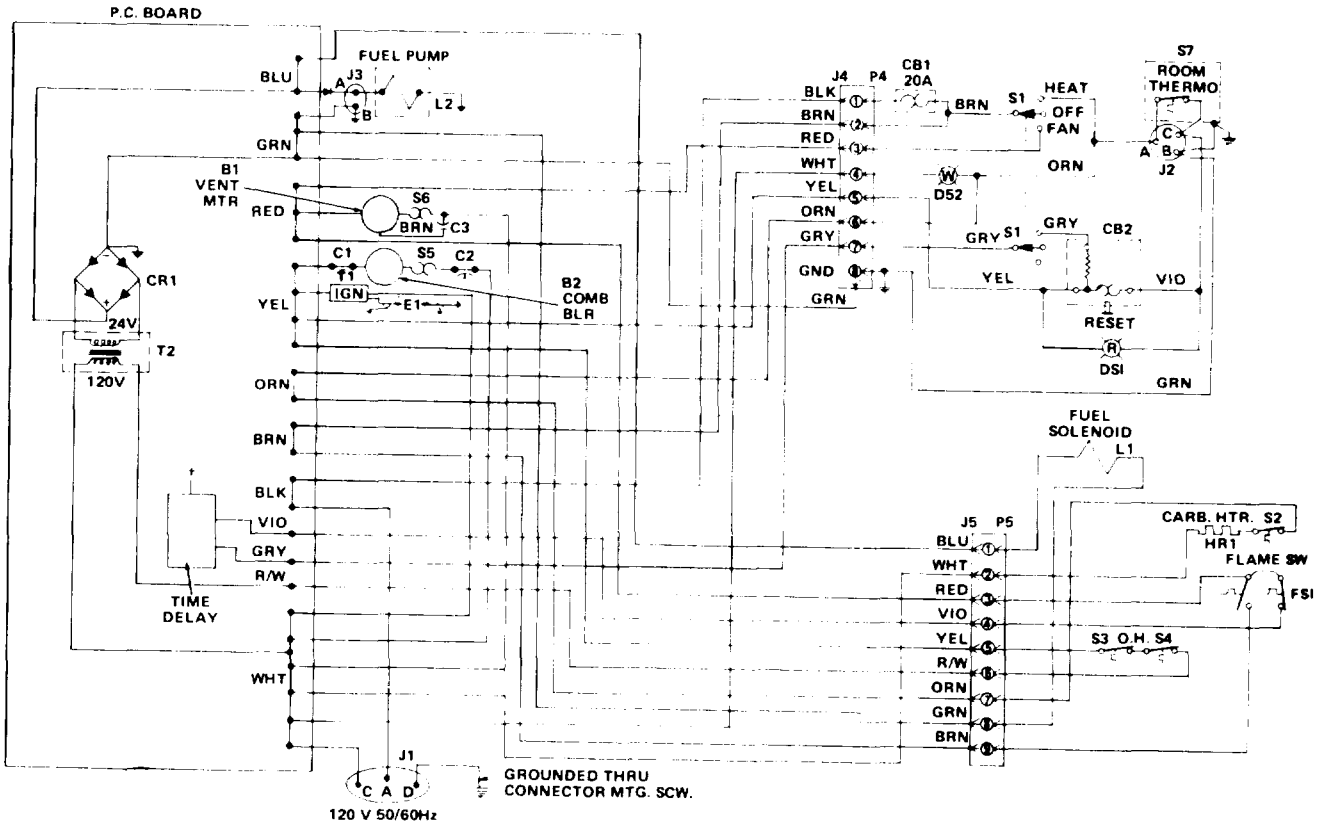

MODEL UH-68G1

**CHAPTER 2
OPERATING INSTRUCTIONS**

Section I. DESCRIPTION AND USE OF OPERATOR'S CONTROLS AND INDICATORS

2-1. OPERATOR CONTROLS AND INDICATORS

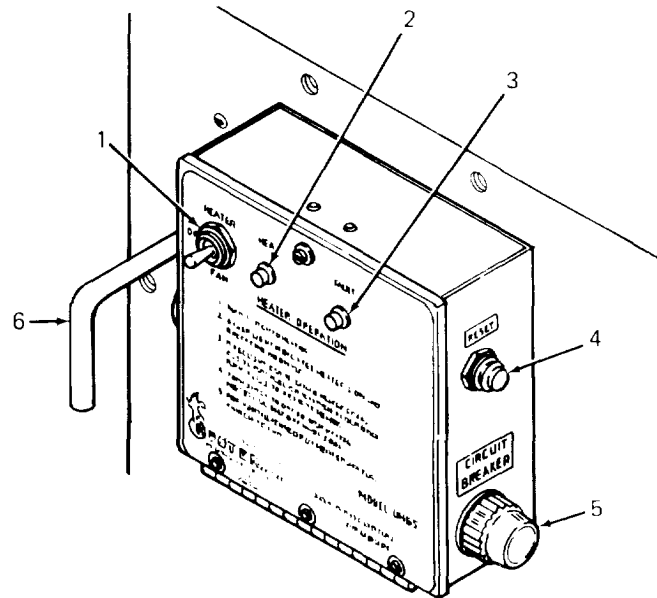
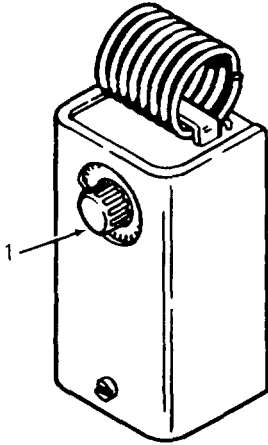

Table 2-1. Controls and Indicators

Key	Control or Indicator	Function
1	HEATER-OFF-FAN switch	Starting and stopping of heater. HEATER position circulates heated air. FAN position circulates unheated air. When switched to OFF from HEATER position, heater continues to run until heater has cooled.
2	White HEAT light	Indicates heater is in HEAT mode.
3	Red FAULT light	Indicates heater has stopped because of: <ul style="list-style-type: none"> a. Ignition failure. b. Lack of fuel. c. Combustion blower failure.
4	RESET circuit breaker	Resets heater circuits causing heater to repeat normal starting procedure.

Table 2-1. Controls and Indicators-Continued

Key	Control or Indicator	Function
5	CIRCUIT BREAKER	Disconnects power if short circuit occurs. Press to reset.
6	Louver handle	Controls air intake louvers to attain optimum air flow.



NOTE

Heat output is constant when heater is operating. Raising thermostat setting does not heat enclosure faster. Set thermostat only to temperature desired.

7	Temperature adjustment knob	For selecting temperature desired in enclosure. Rotate until desired temperature is aligned with index mark.
---	-----------------------------	--

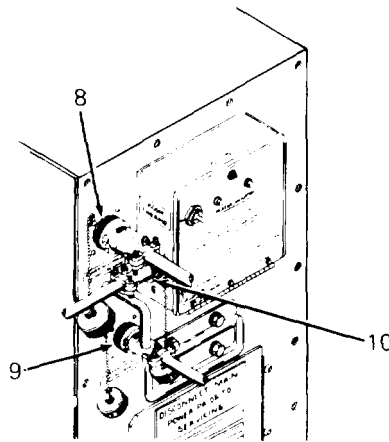

8	POWER RECEPTACLE	Connection for external source of 120 V ac, 50/60 Hz electrical power.
9	EXTERNAL FUEL PUMP RECEPTACLE	Connection for plugging in external electric fuel pump,
10	ROOM THERMO RECEPTACLE	Connection for plugging in remote thermostat which controls heat of enclosure.

Section II. OPERATOR PREVENTIVE MAINTENANCE CHECKS AND SERVICES (PMCS)

2-1.1 INTRODUCTION

a. General. Your Preventive Maintenance Checks and Services table lists the inspections and care of your equipment required to keep it in good operating condition.

(1) Before you operate. Always keep in mind the CAUTIONS and WARNINGS. Perform your before (B) PMCS.

(2) While you operate. Always keep in mind the CAUTIONS and WARNINGS. Perform your during (D) PMCS.

(3) After you operate. Be sure to perform your after (A) PMCS.

(4) If your equipment fails to operate. If your equipment does not perform as required, notify unit maintenance to troubleshoot problem. Report any malfunctions or failures on the proper DA Form 2404, or refer to DA PAM 738-750.

b. PMCS columnar entries.

(1) Item number column. This is the order in which you perform checks and services on (equipment name). The entry in this column will also be used as a source of item numbers for the "TM Item Number" column on DA Form 2404, Equipment Inspection and Maintenance Worksheet, in recording results of PMCS.

(2) Interval columns. The interval column of your PMCS table tells you when to do a certain check or service.

(3) Item to be inspected. Identification of item to be inspected.

(4) Procedures column. The procedures column of your PMCS table tells you how to do the required checks and services. Carefully follow these instructions. If you do not have the tools, or if the procedure tells you to, have the next higher level of maintenance do the work.

(5) Equipment is not ready/available if: column. Entries in this column will be keyed specifically to checks listed in the "procedures" column for the purpose of identifying, for the check, the criteria that will cause the equipment to be classified as not ready/available because of inability to perform its primary Combat Mission. An entry in this column will:

- Identify conditions that make the equipment not ready/available for readiness reporting.
- Deny use of the equipment until corrective maintenance has been performed.

c. Special instructions. Leakage definitions for operator/crew PMCS shall be classified as follows:

Class I Seepage of fluid (as indicated by wetness or discoloration) not great enough to form drops.

Class II Leakage of fluid great enough to form drops but not enough to cause drops to drip from item being checked/inspected.

Class III Leakage of fluid great enough to form drops that fall from the item being checked/inspected.

CAUTION

Equipment operation is allowable with minor leakages (Class I or II). Of course, you must consider the fluid capacity in the item/system being checked/inspected. When in doubt, notify your supervisor.

When operating with Class I or II leaks, continue to check fluid levels as required in your PMCS.

Class III leaks should be reported to your supervisor.

Table 2-2. Operator Preventive Maintenance Checks and Services

NOTE

If the equipment must be kept in continuous operation, check and service only those items that can be checked and serviced without disturbing operation. Make the complete checks and services when the equipment can be shut down.

B—Before Operation

D—During Operation

A—After Operation

Item No.	Interval			ITEM TO BE INSPECTED PROCEDURE	Equipment is Not Ready/ Available If:
	B	D	A		
				<p>FUEL LINE SYSTEM</p> 	

Table 2-2. Operator Preventive Maintenance Checks and Services-Continued

B—Before Operation

D—During Operation

A—After Operation

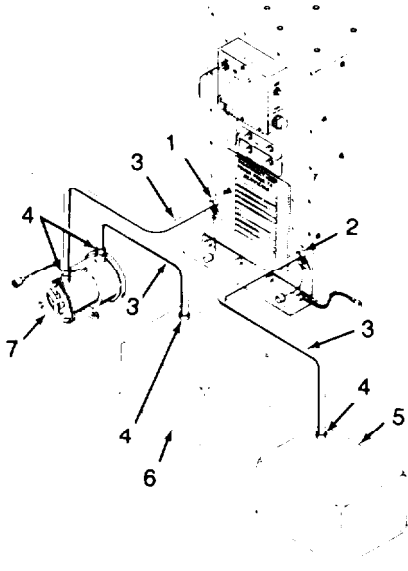
Item No.	Interval			ITEM TO BE INSPECTED PROCEDURE	Equipment is Not Ready/ Available if:
	B	D	A		
1	•			<ul style="list-style-type: none"> Inspect the following fuel system components for leaks: <ol style="list-style-type: none"> (1) Fuel inlet fitting (2) Fuel overflow fitting (3) Fuel lines (4) Fuel connections (5) Fuel overflow container (6) Fuel supply container (7) External fuel pump Tighten any loose connections. <p>EXHAUST SYSTEM</p>	Leak greater than Class I at fitting and any leak in fuel line itself or fuel container.
2		•		<ul style="list-style-type: none"> Inspect entire exhaust system for leaks resulting from damage, corrosion, and/or loose components. inspect through-the-wall installation for evidence of overheated, singed, or burned wood or other flammable building materials. Tighten loose connection. 	Exhaust line punctured or rusted through. Building material damaged by heat.
3			•	<ul style="list-style-type: none"> inspect exhaust system for fresh carbon buildup or other evidence of exhaust leaks. <p>EXTERNAL ELECTRICAL CONNECTIONS</p>	Exhaust line punctured or rusted through.
4			•	<ul style="list-style-type: none"> Check electrical plugs for tight seating in receptacles. Check ground strap for secureness. Tighten loose connections. <p>HEATER CASE</p> 	
5			•	<ul style="list-style-type: none"> Inspect adjustable louvers (1), fixed louvers (2), and screen (3) for obstructions. Remove obstructions. 	

Table 2-2. Operator Preventive Maintenance Checks and Services-Continued

B—Before Operation

D—During Operation

A—After Operation

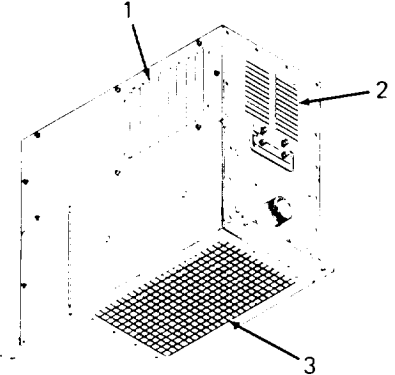
Item No.	Interval			ITEM TO BE INSPECTED PROCEDURE	Equipment is Not Ready/ Available If:
	B	D	A		
6			•	<p>HEATER OPERATION</p> <div style="text-align: center; border: 1px solid black; padding: 5px; width: fit-content; margin: 0 auto;">WARNING</div> <p>Surfaces of and near heat exchanger and exhaust system can become hot enough to cause severe burns if touched.</p> <p>Do not operate heater in enclosure unless exhaust gases are piped outside. Exhaust gases contain carbon monoxide, a colorless, odorless, deadly poisonous gas. Failure to provide proper elimination of the exhaust can cause severe illness or death.</p> <p>Monitor operation of unit using senses of sight, hearing, touch, and smell:</p> <ol style="list-style-type: none"> a. Look for signs of excessive vibration, fuel leaks, exhaust leaks, arcing, overheating of heater and/or electrical components, and incomplete combustion. b. Listen for abnormal noise that may indicate possible failures in motor bearings, fans, fuel feed systems, combustion chamber, and heat exchanger. c. Touch cool portions of heater to determine vibration level. d. Note unusual smells that may indicate overheating, exhaust leaks, heat exchanger leaks, fuel leaks, incomplete combustion, and faulty electrical circuits. e. If inspection indicates combustion problem, open front access door (1) and adjust fuel needle (2) as follows: 	<p>Excessive vibration, fuel leaking, exhaust leaking, defects in electrical system, burned out bearing, damaged fan, leaking heat exchanger.</p> <p>Combustion problems continue after fuel needle adjusted</p>

Table 2-2. Operator Preventive Maintenance Checks and Services-Continued

B—Before Operation

D—During Operation

A—After Operation

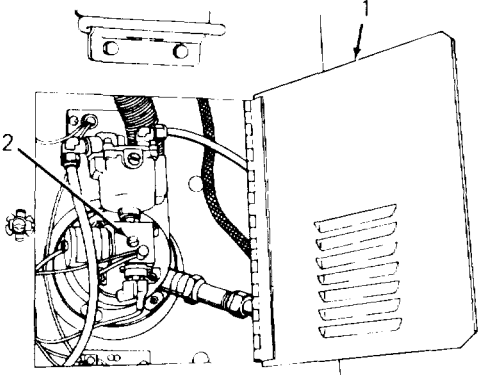
Item No.	Interval			ITEM TO BE INSPECTED PROCEDURE	Equipment is Not Ready/ Available If:
	B	D	A		
				<p style="text-align: center;">CAUTION</p> <p>When turning needle valve all the way in, do not force. Use light pressure to avoid damage to valve.</p>  <p>(1) Turn fuel needle (2) clockwise as far as possible.</p> <p>(2) Turn fuel needle (2) counterclockwise in 1/8-turn increments. Increase fuel flow until there is no odor of unburned fuel and no smoke in exhaust fumes.</p> <p>(3) In low ambient temperatures it may be necessary to increase fuel flow to achieve smooth burner operation.</p>	

SECTION III. OPERATION UNDER USUAL CONDITIONS**2-2. DAILY CHECKS**

Before operation, heater must be connected to 120 V ac, 50/60 Hz electrical power supply and external fuel supply. Temperature is controlled by remote thermostat. Before starting heater, make following checks:

WARNING

Death or serious injury could occur if fuel is not handled carefully. Use in a well-ventilated area away from open flame, arcing equipment, ignition sources, heaters, or excessive heat. Engines must be turned off and cool before refueling. Use proper refueling procedures and equipment to avoid spillage. Do not run engines near open fuel containers. Do not use fuel as a cleaning solvent. DO NOT SMOKE.

a. Ensure plugs are completely inserted and threaded sleeves tightened at the following electrical connections:

(1) POWER RECEPTACLE (8, table 2-1).

(2) EXTERNAL FUEL PUMP RECEPTACLE (9, table 2-1).

(3) ROOM THERMO RECEPTACLE (10, table 2-1).

b. Ensure fuel level in fuel supply container is adequate for the period of operation required. Ensure fuel shut-off valve on fuel supply container is open.

WARNING

Do not operate heater if fuel leakage is detected.

2-3. OPERATING PROCEDURES

Heater can be operated in either of two modes:

a. Heating mode.

b. Fan mode.

2-4. OPERATION IN HEATING MODE

WARNING

Do not operate heater in enclosure unless exhaust gases are piped outside. Exhaust gases contain carbon monoxide, a colorless, odorless, deadly poisonous gas. Failure to provide proper elimination of the exhaust can cause severe illness or death.

- a. Set remote thermostat at desired temperature and open shutoff valve at fuel container.
- b. Place HEATER-OFF-FAN switch (1) in HEATER position. White HEAT light (2) will come on and burner will ignite. Burner will alternately turn off and on in response to thermostat contacts opening and closing. White light will remain on. Ventilating motor circulates warm air from heater.
- c. If ignition does not occur within a predetermined time, power automatically shuts off and red FAULT light (3) will come on. Push RESET button (4) to reactivate starting cycle.

WARNING

Death or serious injury could occur if fuel is not handled carefully. Use in a well-ventilated area away from open flame, arcing equipment, ignition sources, heaters, or excessive heat. Engines must be turned off and cool before refueling. Use proper refueling procedures and equipment to avoid spillage. Do not run engines near open fuel containers. Do not use fuel as a cleaning solvent. DO NOT SMOKE.

- d. If heater shuts down shortly after starting, red FAULT light (3) will come on, Check fuel supply and replenish if necessary. Allow 3 to 5 minutes for heater to cool, and press RESET button (4).
- e. Open or close louvers with louver handle (5) to obtain optimum air intake for the ventilating motor.

2-5. OPERATION IN FAN MODE

- a. Place HEATER-OFF-FAN switch (1) in FAN position.
- b. Ventilating motor will start and white light will come on. There is no thermostat control in fan mode. If heater is still warm from heater operation, warm air will circulate until heat exchanger cools. Otherwise, room temperature will be recirculated.

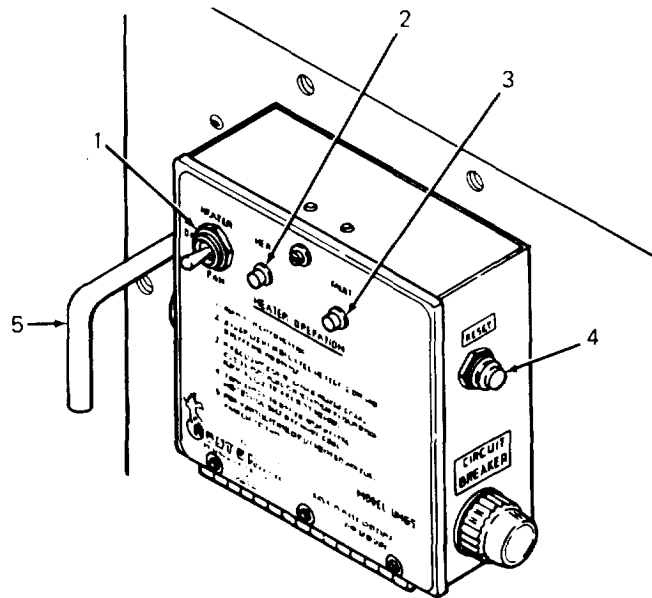

2-6. SHUTDOWN

- a. Place HEATER-OFF-FAN switch in OFF position.

CAUTION

Do not disconnect power cable from POWER RECEPTACLE until heater has completed purge cycle.

- b. For several minutes after operation in heater mode, ventilating motor will continue to run. After heater has cooled, heater will shut off automatically. ■

2-7. OPERATION OF AUXILIARY EQUIPMENT

There are no special instructions for operation of auxiliary equipment. External fuel pump operates in response to heater controls. Thermostat needs only to be set at desired temperature.

2-8. INFORMATION PLATES AND DECALS

Heater has the following identification, warning, and instruction plates and labels:

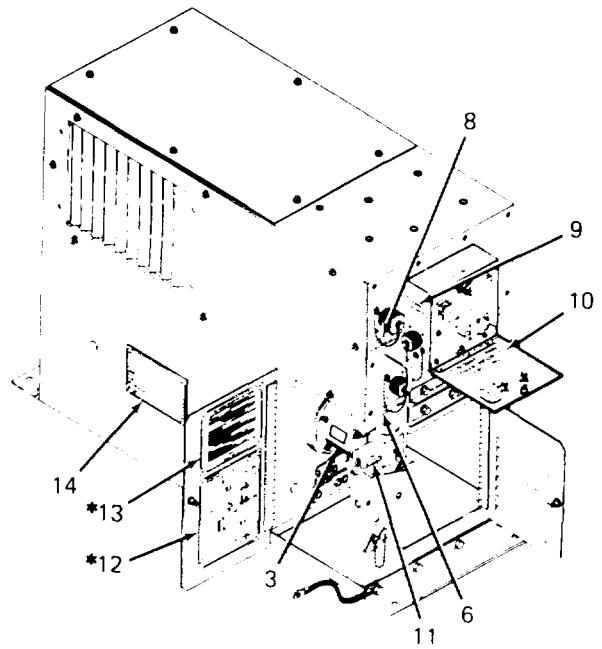
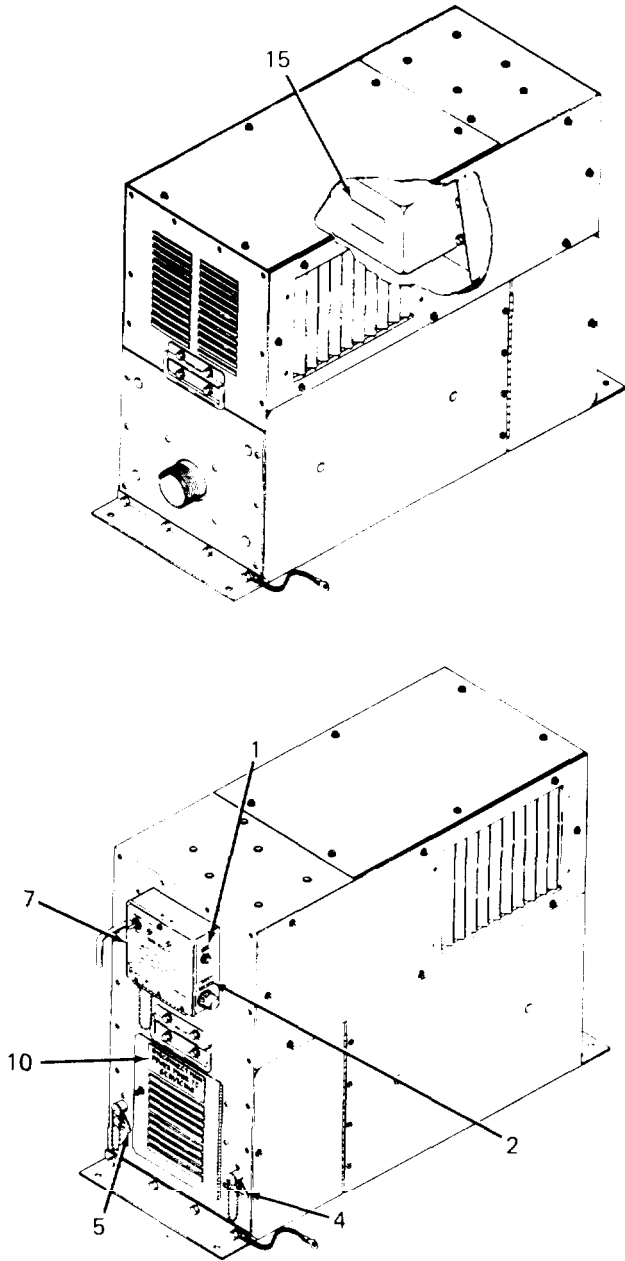

***NOTE**

Items 12 and 13 may be located on opposite panel.

1. **RESET label.** Identifies RESET button.



2. **CIRCUIT BREAKER label.** Identifies CIRCUIT BREAKER button.



3. **Igniter plate.** identifies specific igniter to be used and provides part number.

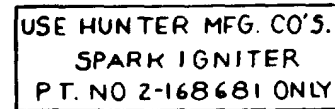

4. **FUEL OVERFLOW tag.** Metal tag identifying FUEL OVERFLOW fitting.

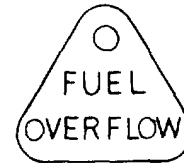

5. **FUEL INLET tag.** Metal tag identifying FUEL INLET fitting.

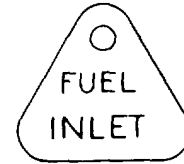

6. **EXTERNAL FUEL PUMP RECEPTACLE label.** Identifies electrical receptacle for plugging in electric fuel pump.



7. **Control box cover name plate.** Identifies HEATER: OFF-FAN switch and provides minimal operating instructions.

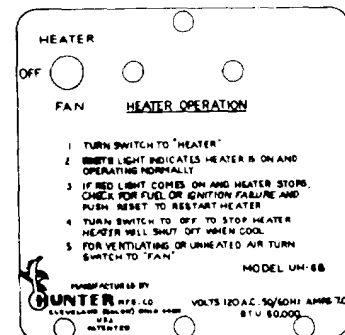

8. **POWER RECEPTACLE label.** Identifies electrical receptacle for plugging in external 120 V ac, 50/60 Hz external power.

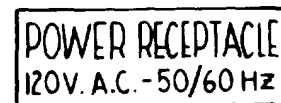

9. **ROOM THERMO decal.** Identifies electrical receptacle for plugging in remote thermostat.



10. **Warning label.** Warns against servicing heater without first disconnecting main power.



11. **FUEL ADJUSTMENT label.** Provides arrow locating fuel needle.

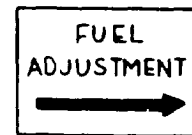

12. Wiring diagram plate. Provides wiring diagram of electrical circuits controlling heater.

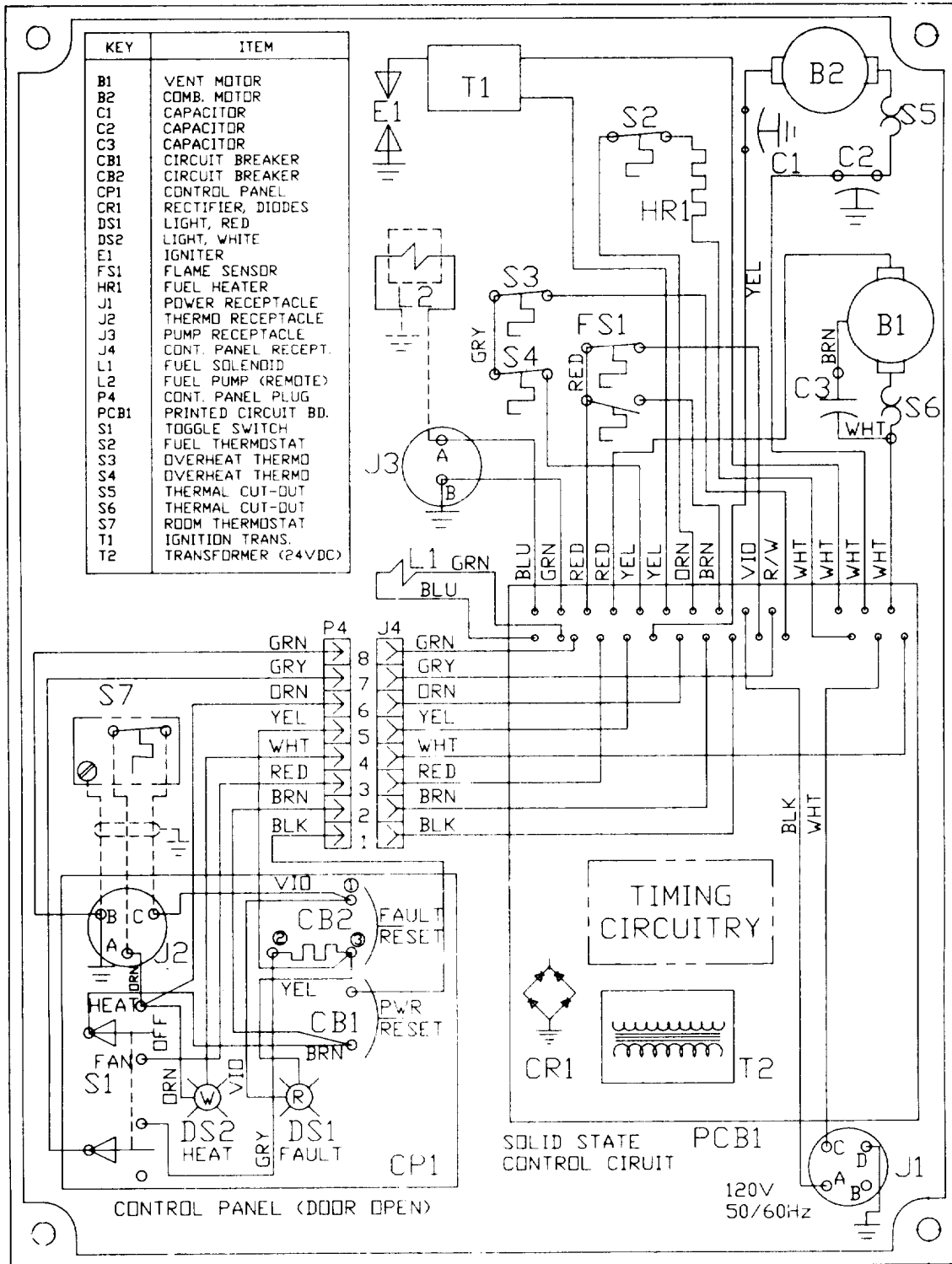

MODEL UH-68G

13. **Sequence of operation information plate.** Highlights sequence of electrical operation of heater and corrective steps to be taken

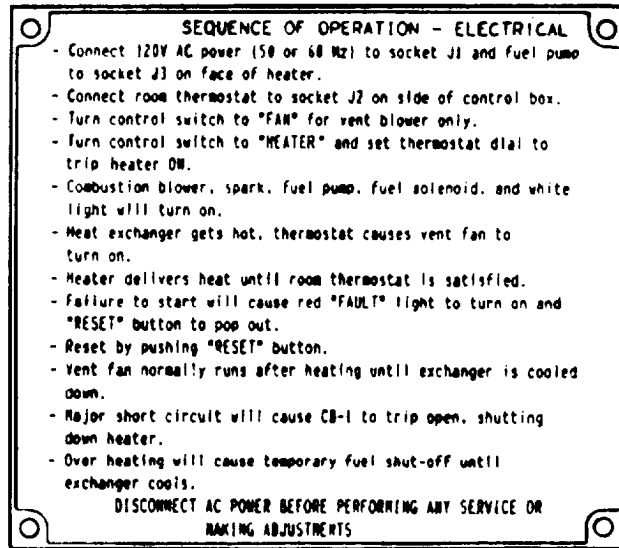

14. **Identification plate.** Provides NSN number, part number, name of manufacturer, contract number, date, serial number, and weight.

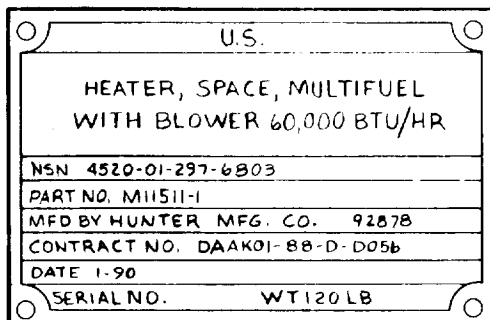

MODEL UH-68G1

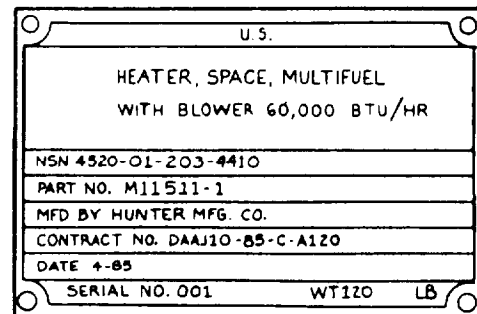

MODEL UH-68G

15. **Identification label.** Identifies ignition transformer. Provides name of manufacturer, part number, electrical values for primary and secondary windings, and states ONE END GROUNDED.

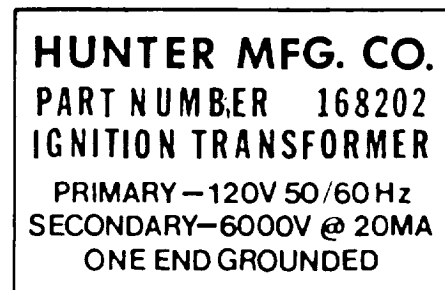

SECTION IV. OPERATION UNDER UNUSUAL CONDITIONS

2-9. OPERATION IN EXTREME COLD, BELOW 10°F (-12°C)

Thermostatically controlled fuel heater automatically heats fuel when temperature drops below 40° ±6°F (4° ±3°C). Preheating of fuel aids combustion and ignition during extremely cold conditions. No operating procedures are required for fuel heater. Take the following steps during extremely cold conditions:

WARNING

Death or serious injury could occur if fuel is not handled carefully. Use in a well-ventilated area away from open flame, arcing equipment, ignition sources, heaters, or excessive heat. Engines must be turned off and cool before refueling. Use proper refueling procedures and equipment to avoid spillage. Do not run engines near open fuel containers. Do not use fuel as a cleaning solvent. DO NOT SMOKE.

- a. Keep fuel tank full to prevent condensation in tank.
- b. Clean snow and ice from fuel tank filler to prevent moisture from entering fuel tank, causing freezing in fuel lines.

2-10. OPERATION AT HIGH ALTITUDES

- a. Heater is designed to operate at elevations up to 10,000 feet (3046 m) above sea level without special service or adjustment.
- b. At 10,000-foot altitude (3048 m), heat output may be reduced approximately 15 percent. This is normal condition which cannot be prevented. Optimum performance can be obtained by following all service instructions carefully.

2-11. OPERATION UNDER RAINY OR HUMID CONDITIONS

- a. Wipe all accessible exposed areas frequently.
- b. Paint all chipped or scratched surfaces to prevent rust.
- c. Cover heater when not in use.

**CHAPTER 3
UNIT MAINTENANCE INSTRUCTIONS**

Section I. LUBRICATION INSTRUCTIONS

NOTE

3-1. LOUVERS

Lubricate louver pivots on both sides of heater with MIL-A-907 antiseize compound.

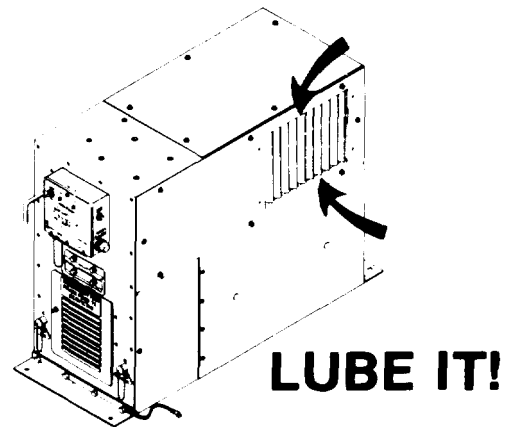

3-2. DOORS

Lubricate left and right side door hinges, control box cover hinge, and front access door hinge with MIL-A-907 antiseize compound.

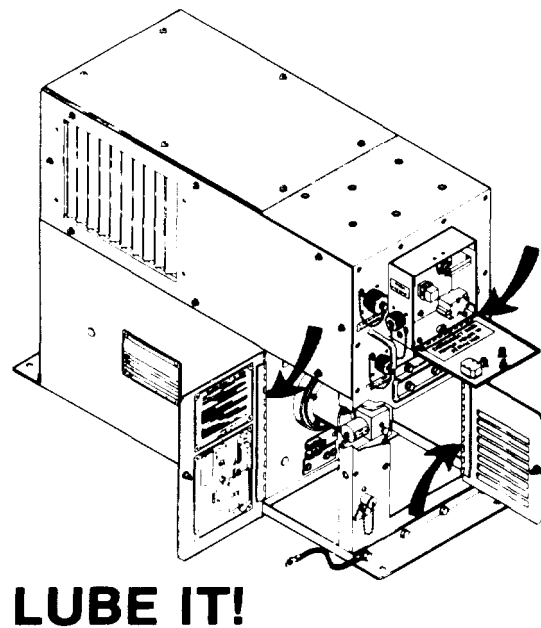

Section II. REPAIR PARTS, SPECIAL TOOLS, TEST MEASUREMENT DIAGNOSTIC EQUIPMENT (TMDE), AND SUPPORT EQUIPMENT

3-3. COMMON TOOLS AND EQUIPMENT

For authorized common tools and equipment, refer to the Modified Table of Organization and Equipment (MTOE) applicable to your unit.

3-4. SPECIAL TOOLS, TMDE, AND SUPPORT EQUIPMENT

For special tools, TM DE, and support equipment, refer to Appendix B and to the repair parts and special tools list, TM 5-4520-253-23P, covering unit and intermediate maintenance for this equipment.

3-5. REPAIR PARTS

Repair parts are listed and illustrated in the repair parts and special tools list, TM 5-4520-253-23P, covering unit and intermediate maintenance for this equipment.

Section III. SERVICE UPON RECEIPT OF EQUIPMENT

3-6. UNPACKING

- a. Avoid damaging shipping carton and crate during unpacking.
- b. Retain empty shipping carton and crate for repackaging.

3-7. INSPECTION

Heater as shipped includes following additional items:

- 1 room thermostat
- 1 power plug (4-pin)
- 1 bushing (used with power plug)
- 1 room thermostat plug (3-pin)
- 1 fuel pump plug (2-pin)
- 2 side covers
- 1 fuel pump

Inspect heater as follows:

- a. Inspect the equipment for damage incurred during shipment. If the equipment has been damaged, report the damage on SF Form 384, Report of Discrepancy (ROD).
- b. Check the equipment against the packing slip to see if the shipment is complete. Report all discrepancies in accordance with the instructions of DA Pam 738-750.
- c. Check to see whether the equipment has been modified.
- d. Inspect for loose or missing hardware.

3-8. MOUNTED POSITION OF HEATER

The heater can be modified to direct air flow upward, downward, or toward either side. For purposes of this description, the initial position will be upright with air flow directed downward.

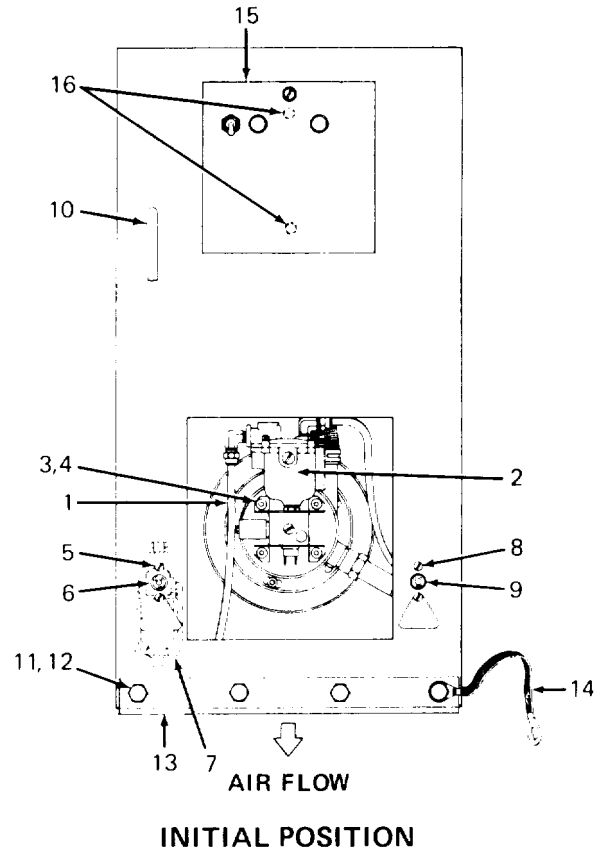

3-9. LEFT SIDE MOUNTING

a. Disconnect fuel line (1) from carburetor (2). Remove four machine screws (3) and lock washers (4) which secure carburetor to burner head. Rotate carburetor 90° so that float bowl is vertical and re-install screws and lock washers. Reconnect fuel line (1) to carburetor (2).

b. Remove screws (5) which secure assembled fuel inlet fitting (6) and fuel filter (7). Remove screws (8) which secure fuel overflow fitting (9). Reverse positions of fittings and their fuel tags. Move fuel inlet fitting (6) and fuel filter (7) as a unit.

c. After fuel inlet fitting (6) is secured, rotate fuel filter (7) so that bowl is vertical.

d. Adjust louver handle (10) to open louvers.

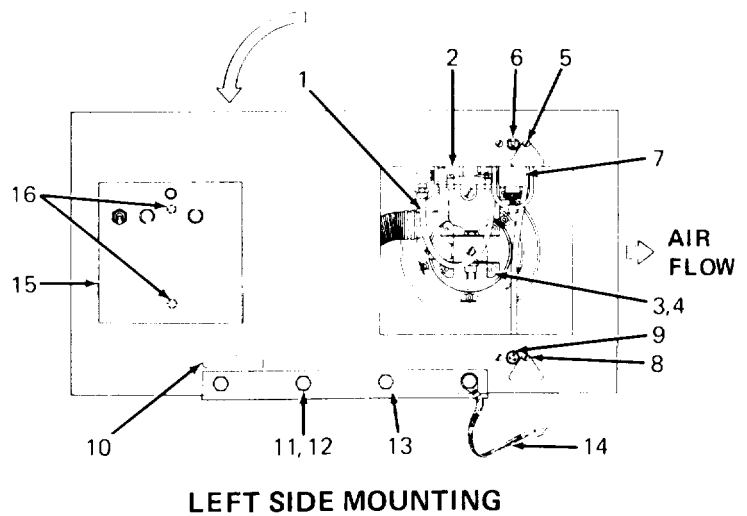

- e. Remove cap screws (11) and washers (12) which fasten mounting brackets (13) and grounding strap (14) to heater case. Reposition brackets to permit mounting of heater on its left side using 5/16-inch bolts or lag screws.
- f. Open control box (15) and unlock two studs (16) which secure control box to heater case. Rotate control box so that cover is upright. Tighten studs. Close control box.

3-10. RIGHT SIDE MOUNTING

- a. Disconnect fuel line (1) from carburetor (2), Remove four machine screws (3) and lock washers (4) which secure carburetor to burner head. Rotate carburetor 90° so that float bowl is vertical and re-install screws and lock washers. Reconnect fuel line to carburetor.
- b. Be sure fuel inlet fitting (6) is secure, and rotate fuel filter (7) so that bowl is vertical.
- c. Adjust louver handle (10) to open louvers.
- d. Remove cap screws (11) and washers (12) which fasten mounting brackets (13) and grounding strap (14) to heater case. Reposition brackets to permit mounting of heater on its right side using 5/16-inch bolts or lag screws.
- e. Open control box (15) and unlock two studs (16) which secure control box to heater case. Rotate control box so that cover is upright. Tighten studs. Close control box.

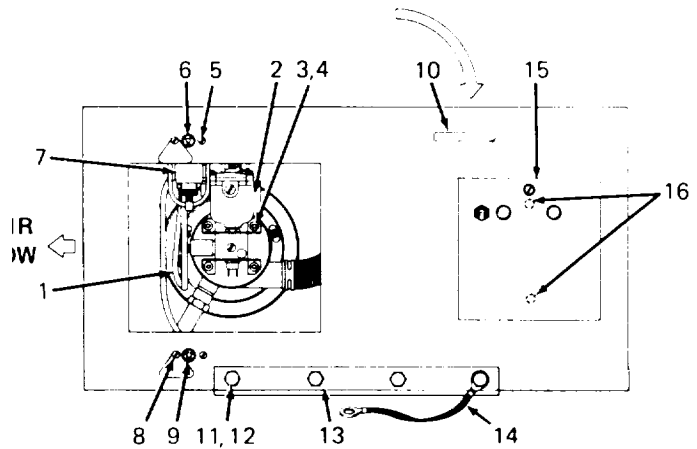

RIGHT SIDE MOUNTING

3-11. INVERTED MOUNTING

- a. Disconnect fuel line (1) from carburetor (2). Remove four machine screws (3) and lock washers (4) which secure carburetor to burner head. Rotate carburetor 180° so that float bowl is vertical. Reinstall screws and lock washers. Reconnect fuel line to carburetor.
- b. Remove screws (5) that secure fuel inlet fitting (6) to front of heater case. Invert position of this fitting and fuel filter (7) as a unit.
- c. After fuel inlet fitting (6) is secured, make sure that fuel filter (7) is vertical.
- d. Adjust louver handle (10) to open louvers.
- e. Remove cap screws (11) and washers (12) which fasten mounting brackets (13) and grounding strap (14) to heater case. Reposition brackets to permit mounting of heater in inverted position using 5/16-inch bolts or lag screws.

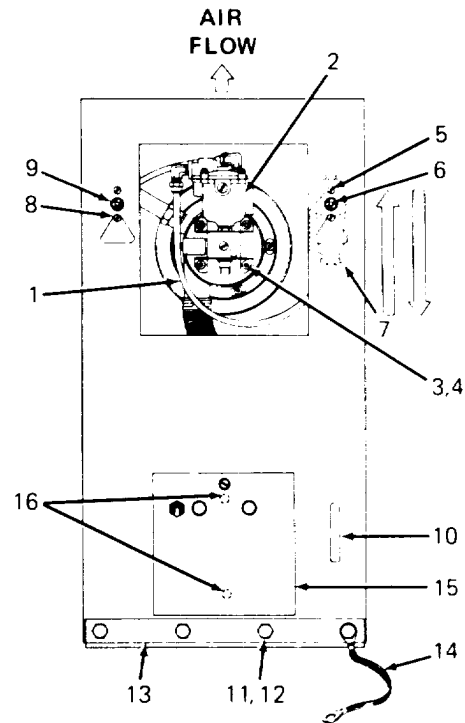

INVERTED MOUNTING

- f. Open control box (15) and unlock two studs (16) which secure control box to heater case. Rotate control box 180° so that cover is upright. Tighten studs. Close control box.

3-12. ADDITIONAL ITEMS REQUIRED

In addition to items furnished with heater (para 3-7), items listed in table 3-1 are necessary for installation.

Table 3-1. Additional Items

Number of Items/ Quantity	Description	Function
AR	3-wire, 16-gauge shielded cable	Connects room thermostat to heater.
AR	3-wire, 12-gauge cable	Connects power plug to power source.
AR	2-wire, 16-gauge cable	Connects fuel pump to heater.
1	Fuel line	Connects fuel container to external fuel pump.
1	Fuel line	Connects external fuel pump to fuel inlet fitting.
1	Fuel line	Connects fuel overflow fitting to overflow container.
2	1/4-inch mounting bolts (washers and nuts, if needed) or lag screws	Secures external fuel pump.
1	Electrical plug	Mates with external fuel pump connector (MS27142-2).
1	Fuel container, with shutoff valve	Provides fuel supply for heater.
1	Overflow container	Collects overflow fuel at fuel overflow fitting of heater.
1	Exhaust line	Mates with 2-inch male pipe fitting at rear of heater.
4	5/16-inch mounting bolts (washers and nuts if needed) or lag screws	Secures heater to mounting surface.

3-13. LOCATION OF HEATER

WARNING

Do not locate heater where expelled exhaust gases can be recirculated into heated space. Exhaust gases contain carbon monoxide, a colorless, odorless, deadly poisonous gas. Failure to provide proper elimination of the exhaust can cause severe illness or death.

- a. Position heater so that exhaust can be vented to outside with short, direct run. Fresh air is normally pulled in through side louvers.
- b. If louvers are obstructed or a greater air flow is required, remove screws (1) and lock washers (2) and lift off bottom cover (3).
- c. Package screws and lock washers and tape or otherwise secure to bottom cover. Identify bottom cover and retain. Bottom cover (3) must be reinstalled when heater is prepared for shipment or storage.
- d. If louvers are not needed as air inlets, install side covers (4). Remove screws (5) and lock washers (6) from side panels (7) and use to install side covers.

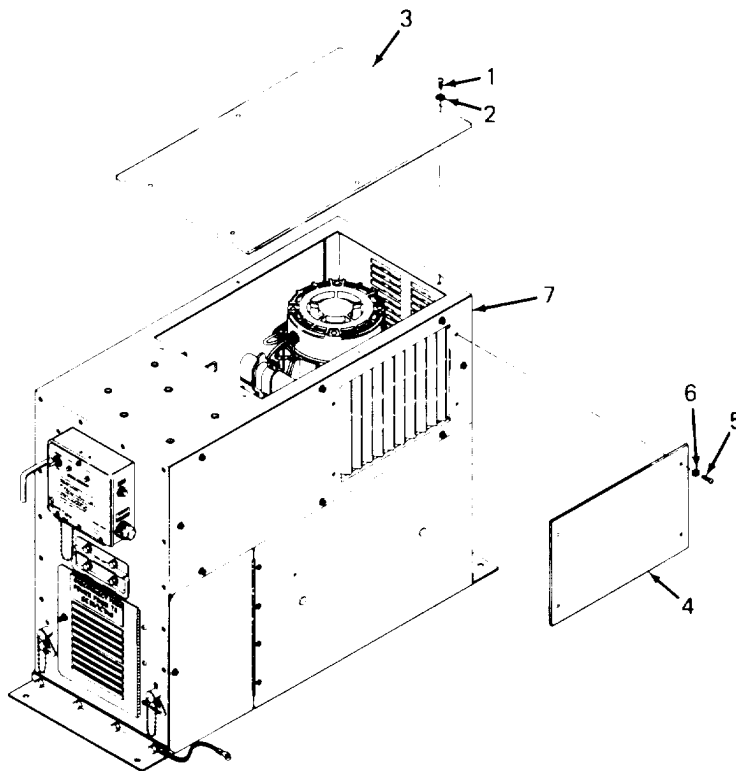

3-14. INSTALLATION

- a. Place heater in selected position and secure in place using 5/16-inch bolts (washers and nuts, if needed) or lag screws.

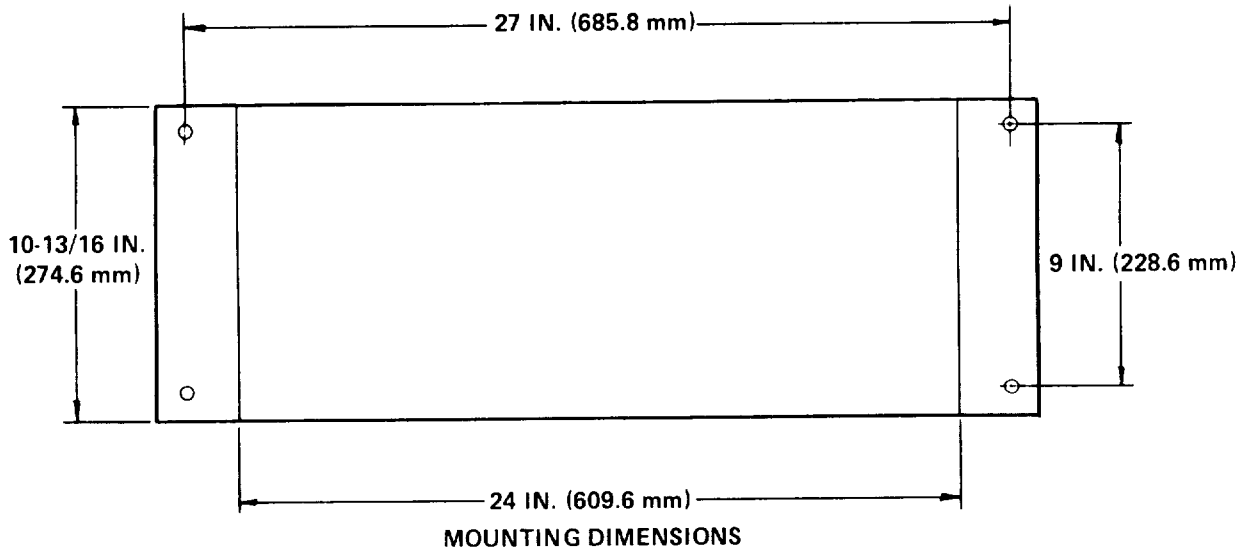

CAUTION

- Do not install room thermostat**
- in line with heater air inlet
 - in line with heater air discharge
 - in drafty area
 - on uninsulated outside wall.

- b. Mount room thermostat in upright position on an inside or insulated wall in the area to be heated. Connect one end of 3-wire, 16-gauge, shielded cable to thermostat. Refer to TEST/ADJUST/REMOVE/INSTALL ROOM THERMOSTAT, page 3-120.
- c. Attach other end of cable to room thermostat plug (3-pin). Refer to REMOVE/INSTALL POWER, FUEL PUMP, AND ROOM THERMOSTAT PLUGS, page 3-124. Connect assembled plug to ROOM THERMO receptacle on side of heater control box.

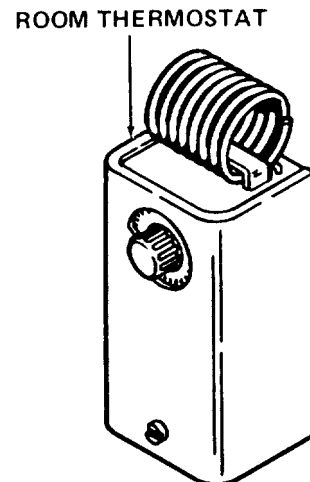

WARNING

Do not connect power cable to 120 V ac, 50/60 Hz electrical source until power cable has been properly connected to power plug.

- d. Install power plug (4-pin) on 3-wire, 12-gauge cable. Refer to REMOVE/INSTALL POWER, FUEL PUMP, AND ROOM THERMOSTAT PLUGS, page 3-124.
- e. At other end of cable, connect black wire to L1 and white wire to L2 of power source. Connect green wire to power source ground.
- f. Install external fuel pump. Secure with 1/4-inch mounting bolts (washers and nuts, if needed) or lag screws. If fuel pump is mounted on wood or other nonconducting material, be sure to ground pump body.
- g. Connect fuel supply line (1) between FUEL INLET fitting (2) and external fuel pump (3). Connect fuel line (4) between fuel container (5) and external fuel pump. Connect line (6) for receiving fuel overflow to FUEL OVERFLOW fitting (7) and overflow container (8). Tighten all connections securely.

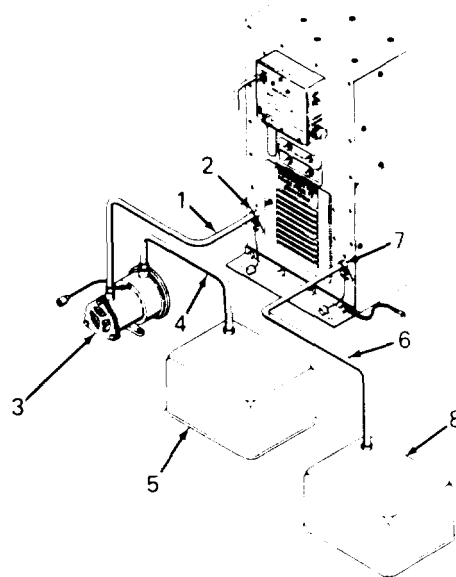

CAUTION

Following step connects 24 V dc circuit. Be sure correct polarity is maintained.

- h. Install fuel pump plug (2-pin) on 2-wire, 16-gauge cable. Refer to REMOVE/INSTALL POWER, FUEL PUMP, AND ROOM THERMOSTAT PLUGS, page 3-124. Connect other end of cable to electrical plug for mating with fuel pump connector and connect to fuel pump. Connect fuel pump plug to EXTERNAL FUEL PUMP RECEPTACLE on front of heater.

WARNING

During operation, exhaust pipe becomes hot enough to cause combustion of wood or other flammable building materials. Provide adequate space and fireproof insulation between exhaust pipe and wall to prevent fire.

- i. Connect exhaust line to exhaust fitting at rear of heater. Extend line outside of building. Be sure there are no sharp bends or turns in line. Be sure there is no reduction of inside diameter of the exhaust line.
- j. Connect grounding strap to ground.
- k. With HEATER-OFF-FAN switch in OFF position, insert power plug into POWER RECEPTACLE on front of heater.
- l. During initial operation of heater, test heated air output carbon monoxide level in accordance with table 3-2, item 15.

3-15. PRELIMINARY SERVICING AND ADJUSTMENT OF HEATER

WARNING

Death or serious injury could occur if fuel is not handled carefully. Use in a well-ventilated area away from open flame, arcing equipment, ignition sources, heaters, or excessive heat. Engines must be turned off and cool before refueling. Use proper refueling procedures and equipment to avoid spillage. Do not run engines near open fuel containers. Do not use fuel as a cleaning solvent. DO NOT SMOKE.

- a. Be sure heater has adequate fuel supply.
- b. Refer to paragraphs 2-4, 2-5, and 2-6 and check operation and shutdown of heater in both heating mode and fan mode.
- c. After allowing heater to warm up, check exhaust fumes for smoke and check for odor of unburned fuel. If either condition occurs, open front access door (1) and adjust fuel needle (2) as follows:

CAUTION

When turning needle valve all the way in, do not force. Use light pressure to avoid damage to valve.

- (1) Turn fuel needle (2) clockwise as far as possible.

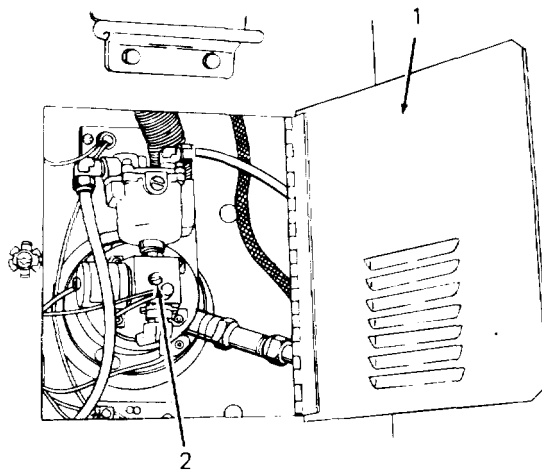

(2) Turn fuel needle (2) counterclockwise in 1/8-turn increments. Increase fuel flow until there is no odor of unburned fuel and no smoke in exhaust fumes.

(3) In low ambient temperatures it may be necessary to increase fuel flow to achieve smooth burner operation.

d. If heater fails to start or operate properly, refer to table 3-3.

Section IV. UNIT PREVENTIVE MAINTENANCE CHECKS AND SERVICES

3-16. GENERAL

a. Systematic, periodic Preventive Maintenance Checks and Services (PMCS) are essential to ensure that heater is ready for operation at all times. In performing all PMCS, always keep in mind and observe WARNINGS and CAUTIONS.

b. The purpose of a preventive maintenance program is to discover and correct defects and deficiencies before they can cause serious damage or complete failure of equipment. Service intervals assigned provide reasonable maintenance levels without excessive interruption of heater's use.

3-17. PREVENTIVE MAINTENANCE CHECKS AND SERVICES

a. PMCS are provided in table 3-2.

b. All defects and deficiencies discovered during maintenance inspections must be recorded, together with corrective action taken, on DA Form 2404, Equipment Inspection and Maintenance Worksheet.

c. Front and side doors provide access in area of carburetor and burner head. Access to combustion blower, ventilating air motor, ignition transformer, and louver linkage is provided by removable side louver panels and bottom cover.

d. Item numbers are assigned to each check or service task. These numbers are to be used as a source of item numbers for the TM Number column on DA Form 2404, Equipment Inspection and Maintenance Worksheet, in recording results of PMCS.

e. The service intervals are divided into two categories: M—Monthly, and Q—Quarterly. A dot (•) is placed in the interval column for each check and service. If the same check or service is made in two intervals, a dot is placed in each applicable column.

f. The ITEM TO BE INSPECTED column lists the item to be checked or serviced.

g. The PROCEDURE column describes the procedure by which the check or service is to be performed, illustrations are included to assist in locating that part of the equipment requiring the check or service.

h. An entry in the Equipment Is Not Ready/Available column will:

(1) Identify conditions that make the heater not ready/available for readiness reporting purposes.

(2) Deny use of heater until corrective maintenance has been performed.

i. For PMCS purposes, leaks shall be classified as follows:

(1) Class I Seepage of fluid (as indicated by wetness or discoloration) not great enough to form drops.

(2) Class II Leakage of fluid great enough to form drops but not enough to cause drops to drip from item being checked/inspected.

(3) Class III Leakage of fluid great enough to form drops that fall from the item being checked/inspected.

Table 3-2. Unit Preventive Maintenance Checks and Services

NOTE

If the equipment must be kept in continuous operation, check and service only those item that can be checked and serviced without disturbing operation. Make the complete checks and services when the equipment can be shut down.

M—Monthly

Q-Quarterly

Item No.	Interval		ITEM TO BE INSPECTED PROCEDURE
	M	Q	
1	✓		<p>CONTROL BOX</p> <p>Unlock stud assembly on control box cover Lower cover. Clean as follows:</p> <p style="text-align: center;"><u>WARNING</u></p> <p>Dry cleaning solvent P-D-680 (safety or Stodard’s Solvent) is potentially dangerous. Avoid repeated and prolonged breathing of vapors and skin contact with the liquid. Do not use near open flame, arcing equipment, or other ignition sources. Always wear eye protection and protective clothing. Flash point of P-D-680 is 100° to 138°F (38° to 59°C).</p> <p>Death or serious injury could occur if compressed air is directed against the skin. Do not use compressed air for cleaning or drying unless the pressure is/has been reduced to 30 psi (207 kPa) or less. When working with compressed air always use chip guards, eye protection, and other personal protective equipment.</p> <p>a. Remove grease, oil, and fuel deposits by wiping with rags dampened with P-D-680 cleaning solvent. Remove excess cleaning solvent and dry with compressed air.</p> <p>b. Clean electrical components by loosening dirt and dust with clean, dry, soft-bristle brush then blowing dirt and dust away using compressed air.</p> <p>c. Dirt deposits that cannot be removed by this method shall be cleaned with minimum quantities of cleaning solvent. Dry immediately with compressed air.</p>

Table 3-2. Unit Preventive Maintenance Checks and Services-Continued

M—Monthly

Q-Quarterly

Item No.	Interval		ITEM TO BE INSPECTED PROCEDURE
	M	Q	
2	•		<div style="display: flex; justify-content: space-around;"> <div style="text-align: center;">  <p>MODEL UH-68G1</p> </div> <div style="text-align: center;">  <p>MODEL UH-68G</p> </div> </div> <p>Inspect electrical wiring (1), connections (2), soldered terminals (3), circuit breakers (4), room thermostat receptacle (5), harness plug (6), HEATER-OFF-FAN switch (7), and Indicator light wires (8).</p>

Table 3-2. Unit Preventive Maintenance Checks and Services-Continued

M—Monthly

Q—Quarterly

Item No.	Interval		ITEM TO BE INSPECTED PROCEDURE
	M	Q	
3	•		<p>HEATER CASE</p> <p>Clean and inspect exterior of heater case as follows:</p> <p style="text-align: center;"><u>WARNING</u></p> <p>Dry cleaning solvent P-D-680 (safety or Stodard's Solvent) is potentially dangerous. Avoid repeated and prolonged breathing of vapors and skin contact with the liquid. Do not use near open flame, arcing equipment, or other ignition sources. Always wear eye protection and protective clothing. Flash point of P-D-680 is 100° to 138°F (38° to 59°C).</p> <p>Death or serious injury could occur if compressed air is directed against the skin. Do not use compressed air for cleaning or drying unless the pressure is/has been reduced to 30 psi (207 kPa) or less. When working with compressed air always use chip guards, eye protection, and other personal protective equipment.</p> <p>a. Remove grease, oil, and fuel deposits by wiping with rags dampened with P-D-680 cleaning solvent. Remove excess cleaning solvent and dry with compressed air.</p> <p>b. Forward to intermediate maintenance for painting and other repair.</p> <p style="text-align: center;"><u>WARNING</u></p> <p>Death or serious injury could occur if precautions are not taken when maintaining this equipment. Position HEATER-OFF-FAN switch to OFF, remove power cable plug from POWER RECEPTACLE, and ground capacitors C1 and C2 prior to gaining access to heater compartments. Terminals of capacitors are accessible at end cover of combustion blower. Always disconnect power cable before making continuity tests or before repairing heater. Always have another person standing by who is trained in electric shock first aid.</p>

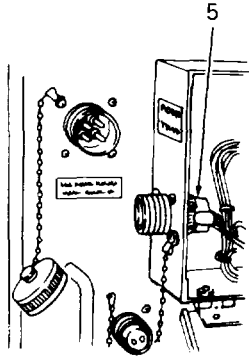
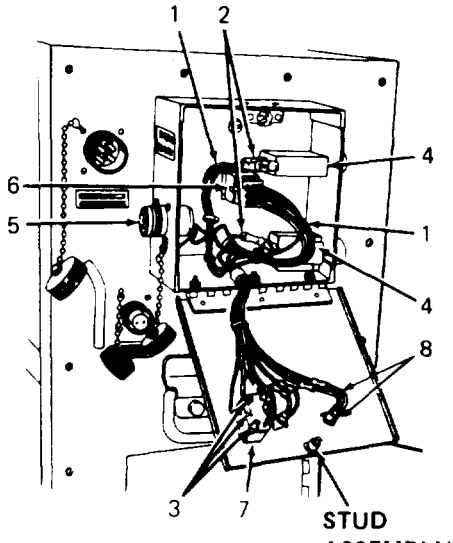
Table 3-2. Unit Preventive Maintenance Checks and Services-Continued

M—Monthly

Q-Quarterly

Item No.	Interval		ITEM TO BE INSPECTED PROCEDURE
	M	Q	
4	•	•	<p style="text-align: center;">WARNING</p> <p>Remove electrical charge from ventilating air motor capacitor C3 by shorting out contacts using tool having insulated handle.</p> <p>Allow sufficient time for heater to cool to room temperature before gaining access to heater compartments.</p> <p>Remove right-hand louver panel (1) and left-hand louver panel (2). Clean and inspect interior including combustion blower and ventilating air motor. Lubricate louver pivots with MIL-A-907 antiseize compound.</p> 
5	•		<p>Open left heater case door (3), front access door (4), right heater case door (5), and control box cover (6). Clean and inspect interior of heater. Lubricate door and cover hinges with MIL-A-907 antiseize compound.</p>

Table 3-2. Unit Preventive Maintenance Checks and Services-Continued

M—Monthly

Q—Quarterly

Item No.	Interval		ITEM TO BE INSPECTED PROCEDURE
	M	Q	
6			<p>FUEL SYSTEM</p>  <p>FUEL FILTER</p> <ul style="list-style-type: none"> • Clean and inspect fuel filter as follows: <ol style="list-style-type: none"> a. Loosen thumbscrew (1) on wire bail (2). Swing bail out from under filter bowl (3). b. Remove bowl, filter element (4), and gasket (5) from filter head (6). <p style="text-align: center;"><u>WARNING</u></p> <p>Dry cleaning solvent P-D-680 (safety or Stoddard's Solvent) is potentially dangerous. Avoid repeated and prolonged breathing of vapors and skin contact with the liquid. Do not use near open flame, arcing equipment, or other ignition sources. Always wear eye protection and protective clothing. Flash point of P-D-680 is 100° to 138°F (38° to 59°C).</p> <p>Death or serious injury could occur if compressed air is directed against the skin. Do not use compressed air for cleaning or drying unless the pressure is/has been reduced to 30 psi (207 kPa) or less. When working with compressed air always use chip guards, eye protection, and other personal protective equipment.</p>

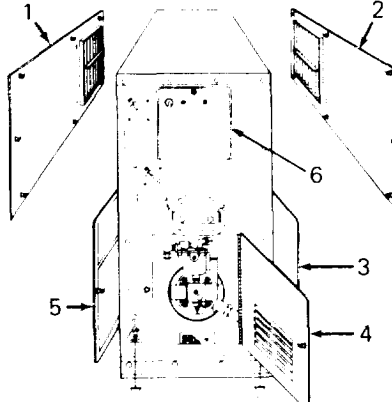
Table 3-2. Unit Preventive Maintenance Checks and Services-Continued

M—Monthly

Q-Quarterly

Item No.	INTERVAL		ITEM TO BE INSPECTED PROCEDURE
	M	Q	
7			<p>c. Clean filter element (4), gasket (5), and bowl (3) in P-D-680 dry cleaning solvent. Shake off excess, and dry parts with compressed air. If filter element cannot be cleaned, replace with new element. If gasket is cracked or damaged, replace it.</p> <p>d. Install filter element (4) and gasket (5) in filter head (6). Place filter bowl (3) over filter element and against gasket.</p> <p>e. Swing wire bail (2) under bowl and tighten thumbscrew(1) against bottom of bowl until leakproof seal is achieved.</p> <p>HEATER</p> <ul style="list-style-type: none"> • Newly installed heater shall be tested for carbon monoxide contamination of heated air prior to regular service. Heater used on seasonal basis shall be tested prior to first use at beginning of season. Upon successful completion of first test, normal test interval shall be used. If for any reason carbon monoxide contamination is suspected, additional tests shall be conducted as necessary to ensure safety personnel. • Test heated air output for carbon monoxide contamination using Carbon Monoxide Tester (8014K [96355] or equal). <p style="text-align: center;"><u>WARNING</u></p> <p style="text-align: center;">Do not operate heater in enclosure unless exhaust gases are piped outside. Exhaust gases contain carbon monoxide, a colorless, odorless, deadly poisonous gas. Failure to provide proper elimination of the exhaust can cause severe illness or death.</p> <p>a. Place HEATER-OFF-FAN switch in HEATER position.</p> <p>b. Allow heater to completely warm up. Set room thermostat high enough to ensure at least 10 minutes of continuous combustion during testing.</p> <p>c. Cut off tips A and B of fresh tube by turning each tube end in tip breaker.</p> <p>d. Insert tip A, marked with red dot, securely into hand pump inlet. Push handle all the way in.</p> <p>e. Line up pump handle guide marks with red dots on pump. Pull handle all the way out and lock with half turn.</p>

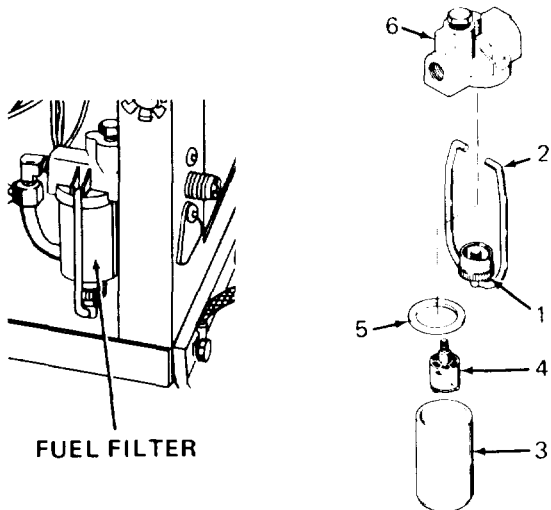
Table 3-2. Unit Preventive Maintenance Checks and Services-Continued

M—Monthly

Q-Quarterly

Item No.	Interval		ITEM TO BE INSPECTED PROCEDURE
	M	Q	
			<p>The diagram illustrates the components and internal structure of a gas detector tube. The top part shows the external assembly, including a handle, a guide, marks on the tube, a tube tip breaker, a check valve, and an inlet. The bottom part shows a cross-section of the tube, identifying the end plugs, reagent, stained area, gas inlet, original resin, protective agent, and specific points B, X, C, D, and A.</p> <p>f. Place tester at center of heater output. Allow air being sampled to flow through detector tube into evacuated pump for 3 minutes. Release handle with half turn. The handle should move back no more than 5 cc (0.306 cu in.).</p> <p>g. Perform step f two more times for a total of 9 minutes of sampling.</p> <p>h. Remove tube from pump and place vertically on concentration chart. Position tube with stained end down so that the boundary between end plug and resin at inlet (point O) is over line O-O and point X is over line X-X. Read air concentration corresponding to length of stain O-C.</p> <p>i. If carbon monoxide level exceeds 35 ppm, isolate cause and repair heater.</p> <p>All data on Pages 3-18 through 3-23 have been deleted.</p>

Section V. TROUBLESHOOTING

3-18. GENERAL

a. This section contains troubleshooting information for locating and correcting most of the operating troubles which are the responsibility of unit maintenance. Each malfunction is followed by a list of tests or inspections which help determine probable causes and corrective actions to take.

b. This manual cannot list all malfunctions that may occur nor all tests or inspection and corrective actions possible to correct those malfunctions. If a malfunction is not listed, or is not corrected by listed corrective actions, notify your supervisor.

c. Table 3-3 lists the common malfunctions which you may find during the operation or maintenance of the heater or its components. Perform the tests/inspections and corrective actions in the order listed.

NOTE

Before you use this table, be sure you have performed all applicable operating procedures.

Table 3-3. Unit Maintenance Troubleshooting

WARNING

Death or serious injury could occur if precautions are not taken when maintaining this equipment. Position HEATER-OFF-FAN switch to OFF, remove power cable plug from POWER RECEPTACLE, and ground capacitors C 1 and C2 prior to gaining access to heater compartments. Terminals of capacitors are accessible at end cover of combustion Mower. Always disconnect power cable before making continuity tests or before repairing heater. Always have another person standing by who is trained in electric shock first aid.

Allow sufficient time for heater to cool to room temperature before gaining access to heater compartments.

MALFUNCTION

TEST OR INSPECTION

CORRECTIVE ACTION

1. HEATER FAILS TO START WHEN SWITCH IS SET TO HEATER; INDICATOR LIGHTS OUT

WARNING

Death or serious injury could occur if fuel is not handled carefully. Use in a well-ventilated area away from open flame, arcing equipment, ignition sources, heaters, or excessive heat. Engines must be turned off and cool before refueling. Use proper refueling procedures and equipment to avoid spillage. Do not run engines near open fuel containers. Do not use fuel as a cleaning solvent. DO NOT SMOKE.

Step 1. Check fuel supply.

Replenish fuel supply.

Table 3-3. Unit Maintenance Troubleshooting – Continued

MALFUNCTION	TEST OR INSPECTION	CORRECTIVE ACTION
-------------	--------------------	-------------------

Step 2. Check for tripped reset circuit breaker.

Press RESET and CIRCUIT BREAKER buttons.

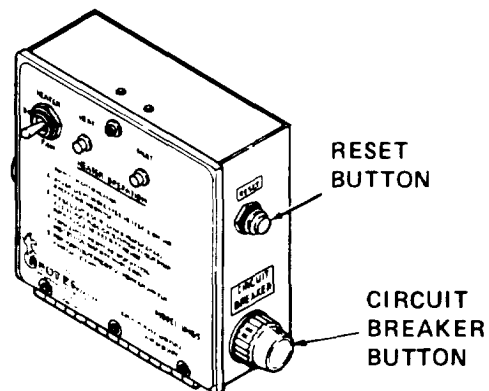

WARNING

Death or serious injury could occur if precautions are not taken when maintaining this equipment. Be sure that any power cables are unplugged/disconnected. Be sure that the equipment is properly grounded. Always have another person standing by who is trained in electric shock first aid.

Step 3. Check power source of 120 V ac.

Restore 120 V ac power or repair power source,

Step 4. Check power cable. Disconnect power cable from POWER RECEPTACLE heater. Check for 120 V ac between pins A and C of plug.

To replace defective power cable, disconnect power cable from 120 V ac source. Replace power plug as described in REMOVE/INSTALL POWER, FUEL PUMP, AND ROOM THERMOSTAT PLUGS, page 3-124. Connect new power cable to 120 V ac source.

Step 5. Check POWER RECEPTACLE. Disconnect power cable and check for continuity through pins A, C, and D of receptacle.

Replace defective receptacle as described in INSPECT/REMOVE/INSTALL POWER RECEPTACLE AND EXTERNAL FUEL PUMP RECEPTACLE, page 3-60.

Table 3-3. Unit Maintenance Troubleshooting – Continued

MALFUNCTION	TEST OR INSPECTION	CORRECTIVE ACTION
-------------	--------------------	-------------------

Step 6. Check HEATER-OFF-FAN switch. Disconnect power cable, open control box, and check for continuity as follows:

- a. Between terminals (6 and 1), switch in FAN position.
- b. Between terminals (3 and 2), switch in FAN position.
- c. Between terminals (3 and 4), switch in HEATER position. Terminal (5) is not used in this application.

Replace defective switch as described in INSPECT/TEST/REMOVE/INSTALL HEATER-OFF-FAN SWITCH, page 3-55.

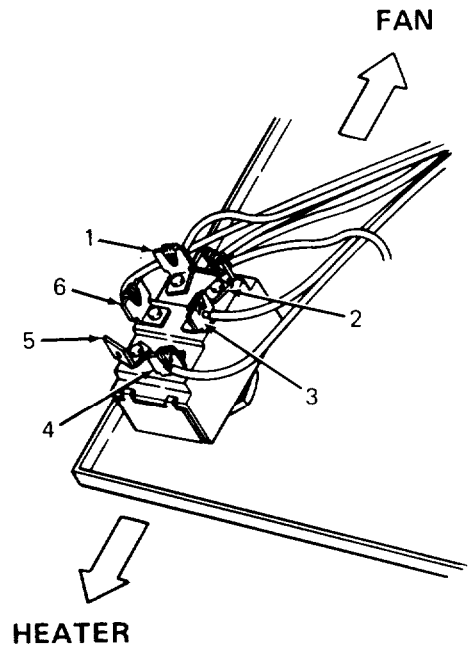

2. HEATER FAILS TO START WHEN SWITCH IS SET TO HEATER, WHITE LIGHT ON, RED LIGHT OFF.

Step 1. Check room thermostat setting for low temperature adjustment.

Set room thermostat temperature adjustment knob to at least five degrees above room temperature.

Step 2. Check for defective room thermostat. Place HEATER-OFF-FAN switch in OFF position. Remove room thermostat cover. Set temperature adjustment knob to maximum and check for continuity between terminals.

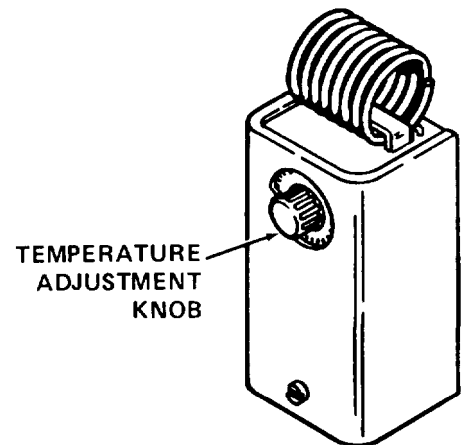

If no continuity, disconnect 3-wire, 16-gauge, shielded cable. Remove thermostat and replace as described in TEST/ADJUST/REMOVE/INSTALL ROOM THERMOSTAT, page 3-120.

Table 3-3. Unit Maintenance Troubleshooting – Continued

MALFUNCTION	TEST OR INSPECTION	CORRECTIVE ACTION
-------------	--------------------	-------------------

WARNING

Death or serious injury could occur if precautions are not taken when maintaining this equipment. Be sure that any power cables are unplugged/disconnected. Be sure that the equipment is properly grounded. Always have another person standing by who is trained in electric shock first aid.

Step 3. Check room thermostat cable. With cable plugged into ROOM THERMO receptacle, remove cover from room thermostat, turn temperature adjustment knob to high setting, place HEATER-OFF-FAN switch in HEATER position, and check for 120 V ac across thermostat switch terminals. No voltage at thermostat switch terminals indicates defective cable or plug. Check plug for loose connections or damage. Check cable wires for continuity.

To replace defective room thermostat plug, refer to REMOVE/INSTALL POWER, FUEL PUMP, AND ROOM THERMOSTAT PLUGS, page 3-124. To replace defective room thermostat cable, refer also to page 3-121.

3. HEATER STARTS, THEN STOPS. RED FAULT LIGHT COMES ON.

WARNING

Death or serious injury could occur if fuel is not handled carefully. Use in a well-ventilated area away from open flame, arcing equipment, ignition sources, heaters, or excessive heat. Engines must be turned off and cool before refueling. Use proper refueling procedures and equipment to avoid spillage. Do not run engines near open fuel containers. Do not use fuel as a cleaning solvent. DO NOT SMOKE.

Step 1. Check for low fuel supply.

Replenish fuel supply.

Step 2. Check fuel shutoff valve.

Be sure fuel shutoff valve is completely open during operation.

Table 3-3. Unit Maintenance Troubleshooting – Continued

MALFUNCTION	TEST OR INSPECTION	CORRECTIVE ACTION
Step 3. Check fuel filter.	Clean and inspect fuel filter as described in table 3-2.	 <p data-bbox="1089 699 1256 722">FUEL FILTER</p>
Step 4. Check fuel pump operation by checking for 24 V dc between fuel pump connector and case.	If 24 V dc is present, replace fuel pump.	
Step 5. Check fuel pump cable. Disconnect cable from heater. Check fuel pump plug for loose connections or damage. Check cable wires for continuity:	Replace defective cable. To remove and install plug, refer to REMOVE/INSTALL POWER, FUEL PUMP, AND ROOM THERMOSTAT PLUGS, page 3-124.	
Step 6. Check external fuel pump receptacle for damage. Inspect for burned contacts and other damage.	Replace defective receptacle as described in INSPECT/REMOVE/INSTALL POWER RECEPTACLE AND EXTERNAL FUEL PUMP RECEPTACLE, page 3-60.	
WARNING		
Death or serious injury could occur if precautions are not taken when maintaining this equipment. Be sure that any power cables are unplugged/disconnected. Be sure that the equipment is properly grounded. Always have another person standing by who is trained in electric shock first aid.		
Step 7. Check external fuel pump receptacle for 24 V dc.	If current is not present, forward heater to intermediate maintenance for testing of PC board.	

Table 3-3. Unit Maintenance Troubleshooting – Continued

MALFUNCTION	TEST OR INSPECTION	CORRECTIVE ACTION
-------------	--------------------	-------------------

	Step 8. Check igniter assembly. Remove igniter from burner head. Inspect for fouling and burned electrode (1). End of electrode must be flush with face (2) to 0.010 inch (0.254 mm) underflush.	
--	--	--

If badly fouled or burned, replace igniter.

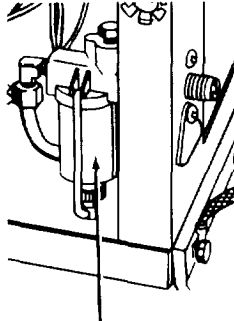
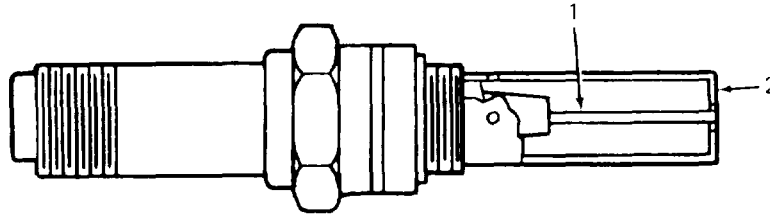

	Step 9. Test transformer assembly.	
--	------------------------------------	--

CAUTION

When checking spark, do not allow spark gap to exceed 1/8 inch (3.175 mm). Larger gap will cause excessively high potential buildup resulting in insulation breakdown either internally or in ignition cable.

- a. Disconnect fuel pump cable from EXTERNAL FUEL PUMP RECEPTACLE, Close shutoff valve at fuel container. Disconnect ignition cable (1) from igniter assembly. Position spring (2) at tip of cable not more than 1/8 inch (3.175 mm) from grounded surface (3). Place HEATER-OFF-FAN switch in HEATER position, If no spark is observed, inspect connector (4) for signs of burning or improper installation.

If defective, replace kitted parts as described in REMOVE/INSTALL/TEST REPAIR IGNITION TRANSFORMER AND CABLE, page 3-110.

Table 3-3. Unit Maintenance Troubleshooting – Continued

MALFUNCTION	TEST OR INSPECTION	CORRECTIVE ACTION
-------------	--------------------	-------------------

b. Inspect terminals (5) and potting of wires (6 and 7) to PC board.

Reconnect as needed. If spark is still not observed, replace transformer (8).
If PC board wires appear defective, forward unit to organizational maintenance.

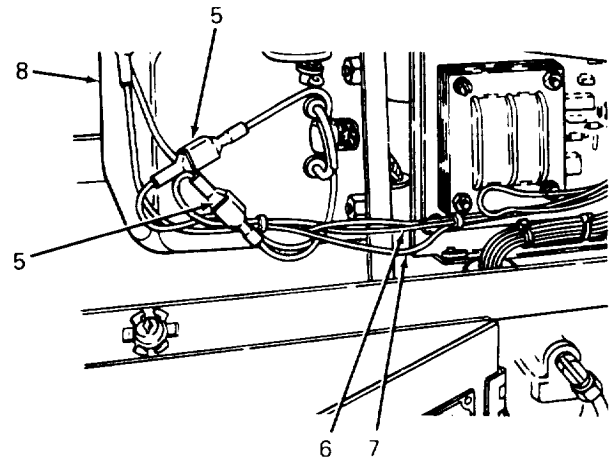
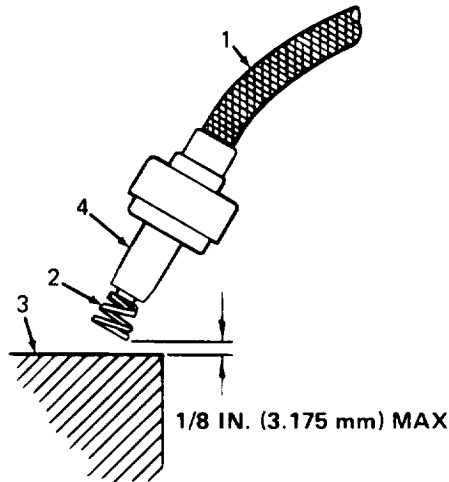

4. HEATER BACKFIRES

Step 1. Check igniter assembly. Remove igniter from burner head. Inspect for fouling and burned electrode (1), End of electrode must be flush with face (2) to 0.010 inch (0.254 mm) underflush.

If badly fouled or burned, replace igniter.

Step 2. Check ignition cable connector for burned spring and damaged connector.

If spring is burned or connector damaged, replace kitted parts as described in REMOVE/INSTALL/TEST/REPAIR IGNITION TRANSFORMER AND CABLE, page 3-110.

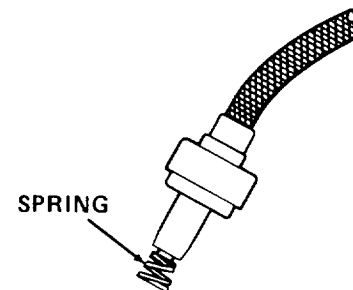
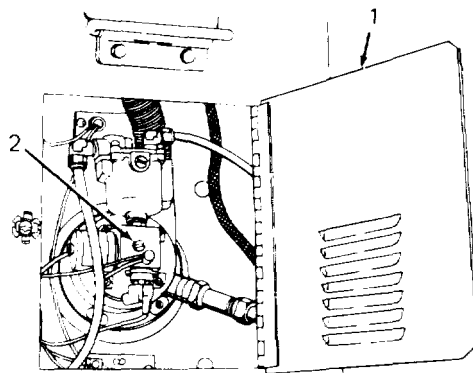

Table 3-3. Unit Maintenance Troubleshooting – Continued

MALFUNCTION	TEST OR INSPECTION	CORRECTIVE ACTION
-------------	--------------------	-------------------

Step 3. Check fuel/air mixture.

Open front access door (1) and adjust fuel needle (2) as follows:



CAUTION

When turning needle valve all the way in, do not force. Use light pressure to avoid damage to valve.

- a. Turn fuel needle (2) clockwise as far as possible.
- b. Turn fuel needle (2) counterclockwise in 1/8-turn increments. Increase fuel flow until there is no odor of unburned fuel and no smoke in exhaust fumes.
- c. In low ambient temperatures it may be necessary to increase fuel flow to achieve smooth burner operation.

Step 4. Check exhaust system for blockage, kinks, or bends.

Straighten exhaust line or replace as needed.

5. HEATER SMOKES

Step 1, Check fuel/air mixture.

Refer to malfunction 4, step 3.

Table 3-3. Unit Maintenance Troubleshooting – Continued

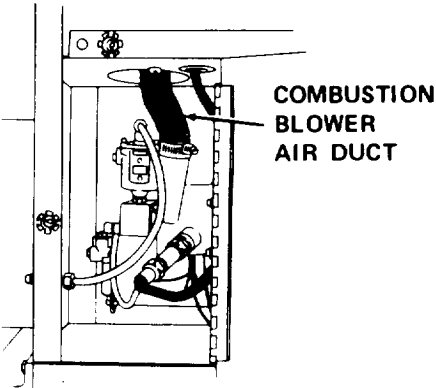
MALFUNCTION	TEST OR INSPECTION	CORRECTIVE ACTION	
Step 2. Check air duct of combustion blower.	If air duct has cracks, holes or is badly dented, replace.	Step 3. Check combustion blower for loss of power.	
	If blower runs slower than usual at normal voltage, forward heater to intermediate maintenance for repair or replacement.		

6. ROOM AIR CONTAMINATED WITH EXHAUST FUMES

WARNING

Do not operate heater in enclosure unless exhaust gases are piped outside. Exhaust gases contain carbon monoxide, a colorless, odorless, deadly poisonous gas. Failure to provide proper elimination of the exhaust can cause severe illness or death.

Step 1. Check exhaust system.

- a. Inspect for leaks caused by corrosion and loose connections.

Replace leaking exhaust line.

- b. Check installation to determine whether exhaust fumes from outside are being drawn back into room or enclosure.

Correct installation if needed. Test heated air as described in table 3-2, item 15, to determine carbon monoxide level.

Step 2. Check heat exchanger.

If heat exchanger is leaking, forward heater to intermediate maintenance for replacement.

Table 3-3. Unit Maintenance Troubleshooting -- Continued

MALFUNCTION	TEST OR INSPECTION	CORRECTIVE ACTION
-------------	--------------------	-------------------

7. RESET CIRCUIT BREAKER TRIPPED REPEATEDLY WHEN HEATER-OFF-FAN SWITCH IS SET TO HEATER

Step 1. Check flame switch and bracket assembly for continuity.

- a. For Model UH-68G1, check receptacle (1) and plug (2) in harness connected to PC board assembly (3). Plug should be securely connected to receptacle.
 If receptacle (1) or plug (2) is damaged or cannot be securely connected, forward heater to intermediate maintenance for replacement.
- b. Remove two screws (4) and lock washers (5). Pull flame switch and bracket assembly (6) out of opening (7) in heater bulkhead.
- c. Disconnect red and violet wires from flame switch (8). Using volt ohmmeter, place one probe against each terminal of flame switch (8). Meter should indicate zero resistance.
- d. Heat bottom of flame switch (8) to 130°F (54°C) and place probes on terminals. Switch should snap (open) and meter should indicate infinite resistance.
- e. Connect red and violet wires to flame switch (8).

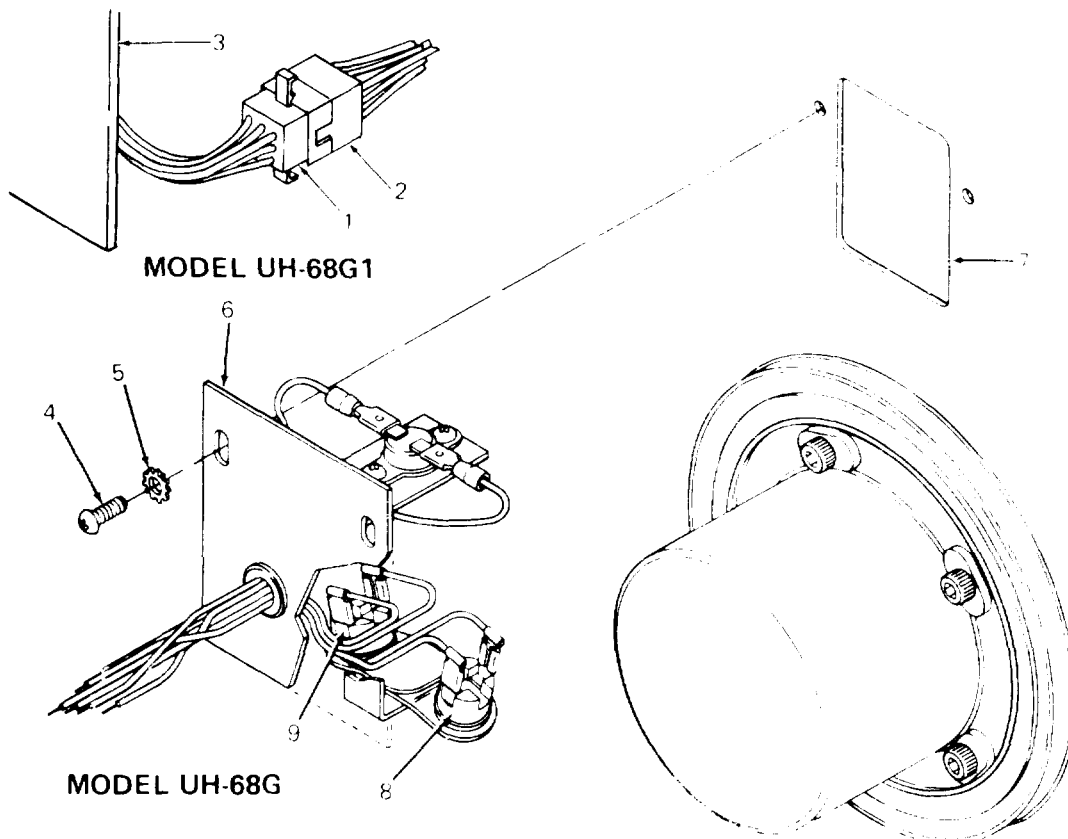

Table 3-3. Unit Maintenance Troubleshooting – Continued

MALFUNCTION	TEST OR INSPECTION	CORRECTIVE ACTION
	f. Disconnect red and brown wires from flame switch (9). Using volt ohmmeter, place one probe against each terminal of flame switch (9). Meter should indicate infinite resistance.	
	g. Heat bottom of flame switch (9) to 130°F (54°C) and place probes on terminals. Switch should snap (close) and meter should indicate zero resistance.	
	h. Connect red and brown wires to flame switch (9).	
	i. Install flame switch and bracket assembly (6) in opening (7) and attach to heater bulkhead using two screws (4) and lock washers (5). With screws loosened, adjust flame switch and bracket assembly downward as far as it will go. This seats the flame switches (8 and 9) against the heat exchanger. Tighten screws (4).	
	If either flame switch (8 or 9) is defective, replace flame switch and bracket assembly (6).	

Section VI. MAINTENANCE PROCEDURES

INDEX

	Page		Page
Carburetor	3-92	Power Receptacle and External Fuel	3-60
Circuit Breaker	3-41	Pump Receptacle	
Combustion Blower	3-100	Printed Circuit (PC) Board	3-65
Control Box	3-37	Assembly	
Data Plates	3-80	RESET Circuit Breaker	3-43
Doors and Bottom Cover	3-76	Room Thermostat Receptacle	3-39
Fuel Filter	3-89	Room Thermostat	3-120
Fuel Lines and Fittings	3-85	Safety Thermostats and Flame	3-105
HEAT and FAULT Lights	3-58	Switch and Bracket Assembly	
Heater Case Assembly	3-66	Side Panels and Louver Linkage	3-71
Heater Case Covers	3-123	Solenoid	3-97
HEATER-OFF-FAN Switch	3-55	Ventilating Air Motor	3-102
Igniter Assembly	3-117	Wire Terminals	3-49
Ignition Transformer and Cable	3-110	Wiring Harness, Control Box	3-45
Labels	3-84	Wiring Harness Plug	3-46
Power, Fuel Pump, and Room	3-124	Wiring Harness Wires	3-51
Thermostat Plugs			

3-19. GENERAL INSTRUCTIONS

Maintenance instructions in this section will list resources required, personnel required, and equipment condition for the start of the procedure. Note the following:

- Resources required are not listed unless they apply to the procedure.
- ⌘ • Personnel required are listed only if the task requires more than one. If PERSONNEL is not listed, it means one person can do the task.
- The normal standard equipment condition to start a maintenance task is heater shut down and at room temperature. EQUIPMENT CONDITION is not listed unless some other condition is required besides power "off and equipment cooled.

CONTROL BOX ASSEMBLY PROCEDURES INDEX

PROCEDURE	PAGE
Inspect/Remove/Install Control Box	3-37
Inspect/Remove/Install Room Thermostat Receptacle	3-39
Inspect/Test/Remove/Install Circuit Breaker	3-41
Inspect/Test/Remove/Install RESET Circuit Breaker	3-43
Inspect Control Box Wiring Harness	3-45
Repair Control Box Harness Plug	3-46
Repair Wire Terminals	3-49
Replace Control Box Harness Wires	3-51
Inspect/Test/Remove/Install HEATER-OFF-FAN Switch	3-55
Remove/Install HEAT and FAULT Lights	3-58
Inspect/Remove/Install Power Receptacle and External Fuel Pump Receptacle	3-60
Inspect Printed Circuit (PC) Board Assembly	3-65

INSPECT/REMOVE/INSTALL CONTROL BOX

TOOLS: Tool kit, service, refrigeration unit
NSN 5180-00-596-1474

REFERENCES: Table 3-2 for cleaning procedure for control box.

GENERAL SAFETY INSTRUCTIONS:

Power off.
Heater cool.

INSPECTION :

WARNING

Death or serious injury could occur if precautions are not taken when maintaining this equipment. Position HEATER-OFF-FAN switch to OFF, remove power cable plug from POWER RECEPTACLE, and ground capacitors C1 and C2 prior to gaining access to heater compartments. Terminals of capacitors are accessible at end cover of combustion blower. Always disconnect power cable before making continuity tests or before repairing heater. Always have another person standing by who is trained in electric shock first aid.

Allow sufficient time for heater to cool to room temperature before gaining access to heater compartments.

1. Release stud (1) in control box cover and open control box as shown. Check RESET circuit breaker (2), circuit breaker (3), FAULT light (4), HEAT light (5), HEATER-OFF-FAN switch (6), and room thermostat receptacle (7) for security.

INSPECT/REMOVE/INSTALL CONTROL BOX (CONT)

2. Check quick disconnect terminals (8), ring terminals (9), and butt connectors (10) for loose connections. Replace loose butt connectors.
3. Check HEATER OFF FAN soldered wire connections (11) for broken solder
4. Check for loose wires (12) at room thermostat receptacle (7) inside control box.
5. Check stud (1) for security, bent or broken pins, and other damage. Replace defective stud by removing solid washer (13). Install new stud and press on new washer (13).
6. Check stud receptacle (14) for security and distortion. Tighten or replace rivets (15) as needed. Remove defective receptacle by drilling out rivets. Install new receptacle.

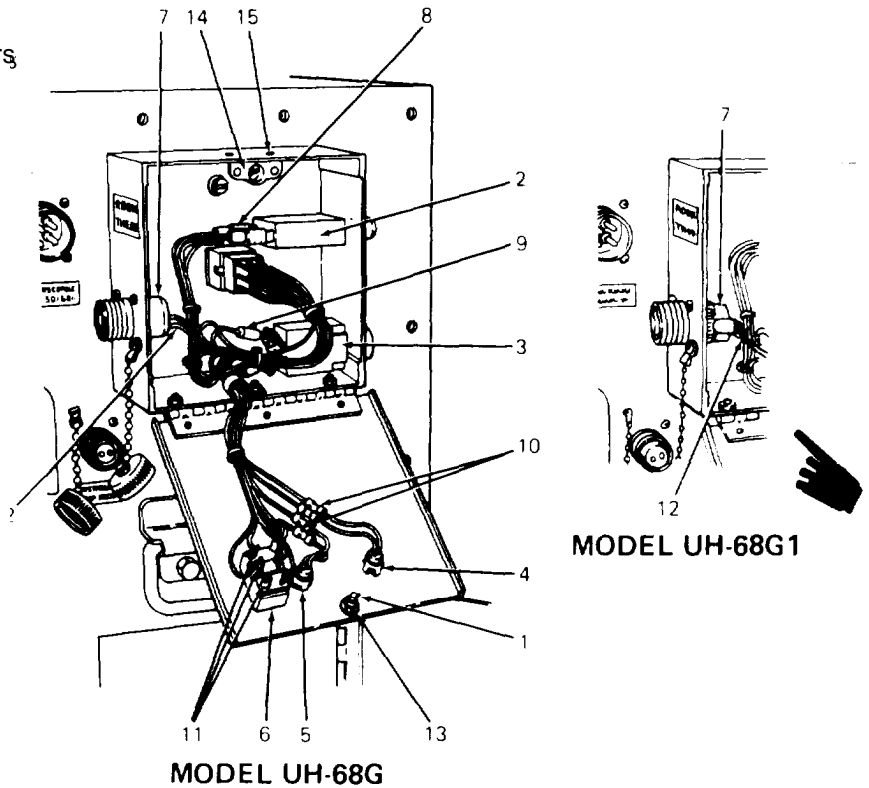

7. If control box needs cleaning, refer to table 3-2.

REMOVAL:

1. Release stud (1) and open control box.
2. Disconnect control box harness by pulling plug (2).
3. Unlock studs (3) and lift off control box assembly (4).
4. Check camlock receptacles (16) in heater case wall. Replace defective receptacles.

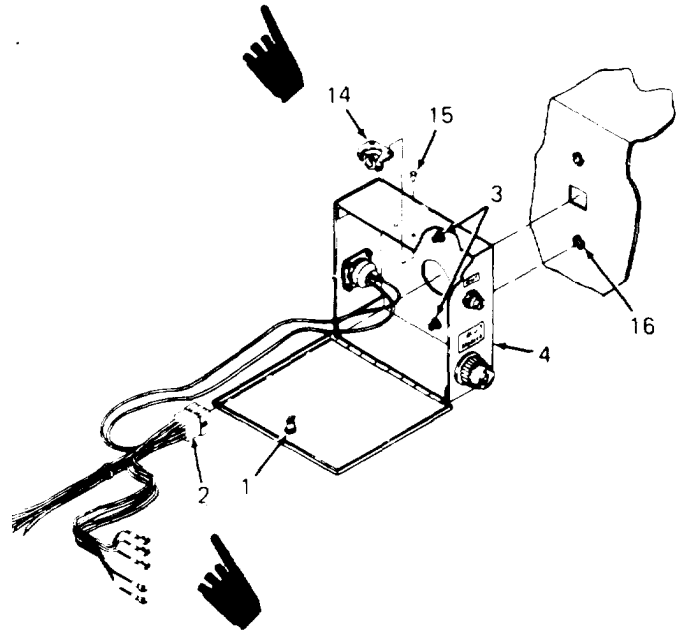

INSTALLATION:

1. Align studs (3) with pair of receptacles in heater case. Tighten studs.
2. Connect plug (2) to receptacle in heater case.
3. Close control box cover and secure with stud (1).

INSPECT/REMOVE/INSTALL ROOM THERMOSTAT RECEPTACLE

TOOLS: Tool kit, service, refrigeration unit
 NSN 5180-00-596-1474

Solder gun kit
 NSN 3439-00-930-1638

MATERIALS/PARTS: Sealant (Item 10, Appendix E)
 Solder (Item 12, Appendix E)
 Tape (Item 14, Appendix E)
 Room Thermostat Receptacle

GENERAL SAFETY INSTRUCTIONS:

Power off.
 Heater cool.

INSPECTION:

1. Check for presence of dust cap (1) and chain (2).
2. Check threads on room thermostat receptacle (3) and inside dust cap (1) for stripping and crossing.
3. Carefully inspect for signs of arcing, burning, or other damage.

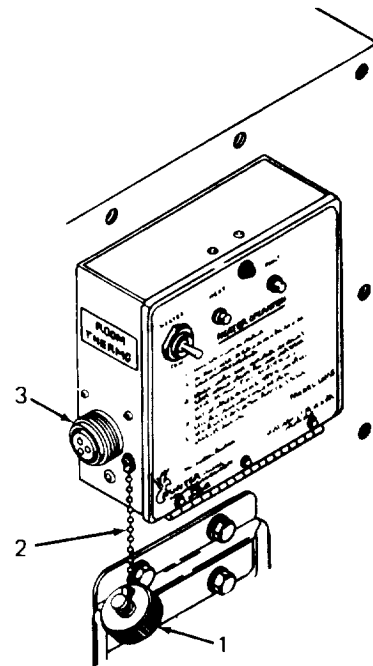

WARNING

Death or serious injury could occur if precautions are not taken when maintaining this equipment. Position-HEATER-OFF-FAN switch to OFF, remove power cable plug from POWER RECEPTACLE, and ground capacitors C1 and C2 prior to gaining access to heater compartments. Terminals of capacitors are accessible at end cover of combustion blower. Always disconnect power cable before making continuity tests or before repairing heater. Always have another person standing by who is trained in electric shock first aid.

4. Open control box cover and check for damage to room thermostat receptacle inside control box. Replace defective receptacle.

INSPECT/REMOVE/INSTALL ROOM THERMOSTAT RECEPTACLE (CONT)

REMOVAL:

1. Remove screw (1), lock washers (2 and 3), and nut (4) attaching ground wire (5).

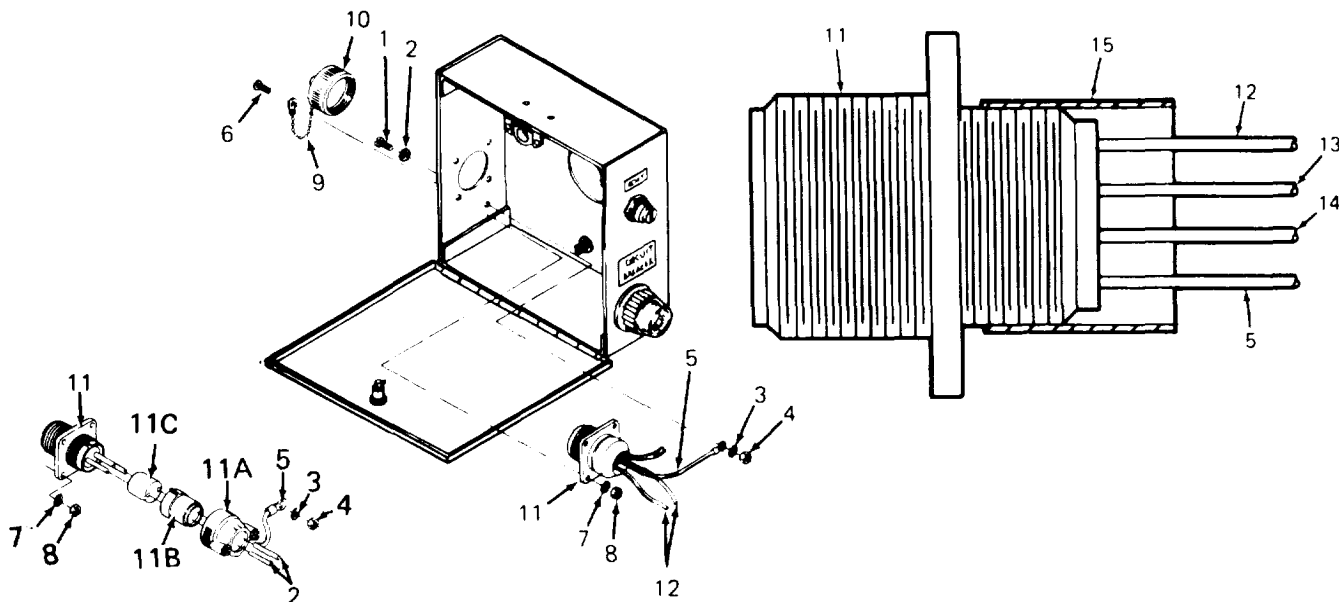

MODEL UH-68G1

MODEL UH-68G

2. Remove four screws (6), lock washers (7), and nuts (8). One screw (6) also attached chain (9) of dust cover (10), Retain chain and dust cover.
3. Pull room thermostat receptacle (11) out of mounting hole from inside control box.
4. For Model UH-68G, control box harness wires connected to room thermostat receptacle (11) are potted to the receptacle. To remove receptacle, cut orange wire (12), green harness wire (13), violet wire (14), and ground (green) wire (5) as close to receptacle as possible. Discard receptacle. Harness wires are long enough to allow cutting close to receptacle and installing new receptacle.
5. For Model UH-68G 1, control box harness wires connected to room thermostat receptacle (11) are soldered and mechanically sealed to the receptacle. To disassemble and remove receptacle, unscrew endbell (11A) from room thermostat receptacle and slide it back over the wires (5, 12, 13, and 14). Pull back ferrule (11B) and grommet (11C) to expose soldered ends of the wires. Unsolder or cut wires as close to receptacle as possible.

INSTALLATION:

1. Strip 1/4 inch (6.35 mm) of insulation from the cut ends of orange wire (12), green harness wire (13), violet wire (14), and ground (green) wire (5).
2. For Model UH-68G1, thread wires (5, 12, 13, and 14) through endbell (11A) and ferrule (11B). Thread the stripped end of each wire through grommet (11C) as follows:
 - a. Slide out orange wire (12) through grommet (11C) opening A.
 - b. Slide out green harness wire (13) and ground (green) wire (5) through opening B.
 - c. Slide out violet wire (14) through grommet opening C.

INSPECT/REMOVE/INSTALL ROOM THERMOSTAT RECEPTACLE (CONT)

3. Solder wires(12, 13, 14, and 5) to new room thermostat receptacle (11) as follows:
 - a. Solder orange wire (12) to terminal A.
 - b. Solder green harness wire(13) and ground (green) wire (5) to terminal B.
 - c. Solder violet wire (14) to terminal C.
4. For Model UH68G, make potting rim (15) around room thermostat receptacle (11) using tape. Rim must project beyond receptacle around wires (12, 13, 14, and 5) 1/4 inch (6.35 mm) or more; fill rim with sealant and allow 8 hours to cure.
5. For Model UH-68G1, push grommet (11C) into rear of room thermostat receptacle (11), seat ferrule (11B) over grommet, and tighten endbell (11A) to threads on rear of receptacle.
6. Position room thermostat receptacle (11) in mounting hole from inside control box.
7. Secure room thermostat receptacle (11) with four screws (6), lock washers (7), and nuts (8). Use one screw (6) to attach chain (9) of dust cover (10).
8. Attach ground wire (5) using screw (1), lock washers (2 and 3), and nut (4).

INSPECT/TEST/REMOVE/INSTALL CIRCUIT BREAKER

TEST EQUIPMENT: Volt ohmmeter

TOOLS: Tool kit, service, refrigeration unit
NSN 5180-00-596-1474

GENERAL SAFETY INSTRUCTIONS:

Power off.
Heater cool

INSPECTION:**WARNING**

Death or serious injury could occur if precautions are not taken when maintaining this equipment. Position HEATER-OFF-FAN switch to OFF, remove power cable plug from POWER RECEPTACLE, and ground capacitors C1 and C2 prior to gaining access to heater compartments. Terminals of capacitors are accessible at end cover of combustion blower. Always disconnect power cable before making continuity tests or before repairing heater. Always have another person standing by who is trained in electric shock first aid.

Allow sufficient time for heater to cool to room temperature before gaining access to heater compartments.

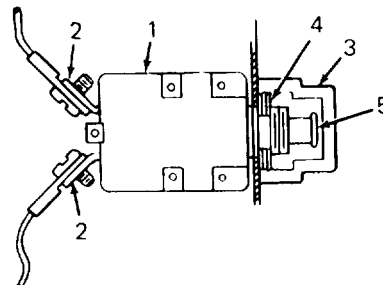

1. Check for cracked or broken body (1) and damaged terminals (2).
2. Remove flexible seal (3) and examine threads of circuit breaker and adapter (4). Replace seal.
3. If circuit breaker is in tripped position, depress button (5).

INSPECT/TEST/REMOVE/INSTALL CIRCUIT BREAKER (CONT)

TESTING:

1. Remove ring terminal from at least one circuit breaker terminal (2).
2. Using volt ohmmeter, check circuit breaker for continuity. If circuit breaker is open and continuity cannot be restored by pressing button, replace circuit breaker.

REMOVAL:

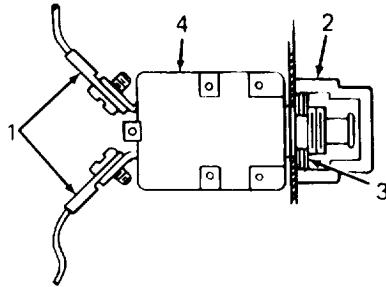

1. Unscrew flexible seal (2) and remove adapter (3).
2. Pull circuit breaker (4) out of mounting hole from inside control box.
3. Disconnect ring terminals (1).

INSTALLATION:

1. Connect ring terminals (1) to circuit breaker terminals.
2. Install circuit breaker (4) in mounting hole from inside control box.
3. Install adapter (3) and tighten securely. Screw flexible seal (2) onto adapter.

INSPECT/TEST/REMOVE/INSTALL RESET CIRCUIT BREAKER

TEST EQUIPMENT: Volt ohmmeter

GENERAL SAFETY INSTRUCTIONS:

Power off.
Heater cool.

INSPECTION:**WARNING**

Death or serious injury could occur if precautions are not taken when maintaining this equipment. Position HEATER-OFF-FAN switch to OFF, remove power cable plug from POWER RECEPTACLE, and ground capacitors C1 and C2 prior to gaining access to heater compartments. Terminals of capacitors are accessible at end cover of combustion blower. Always disconnect power cable before making continuity tests or before repairing heater. Always have another person standing by who is trained in electric shock first aid.

Allow sufficient time for heater to cool to room temperature before gaining access to heater compartments.

1. Check for cracked or broken body (1) and damaged quick disconnect terminals (2).

NOTE

Removal of seal boot (3) allows RESET circuit breaker to back out of mounting hole. Hold circuit breaker by hand during inspection.

2. Remove seal boot (3) and examine threads of RESET circuit breaker. Replace seal.
3. If circuit breaker is in tripped position, depress button (4),

TESTING:

1. Disconnect violet wires (5), yellow wires (6), and grey wire (7) at quick disconnect terminals (2).
2. Using volt ohmmeter, check RESET circuit breaker for continuity as follows:
 - a. Place one probe on terminal 1 and other probe on terminal 3. Meter should indicate continuity.
 - b. Place one probe on terminal 2 and other probe on terminal 3. Meter should indicate continuity.
3. If either test 2.a or b fails to indicate continuity, replace circuit breaker. Connect violet wires (5) to terminal 1, yellow wires (6) to terminal 3, and grey wire (7) to terminal 2.

INSPECT/TEST/REMOVE/INSTALL RESET CIRCUIT BREAKER (CONT)

REMOVAL:

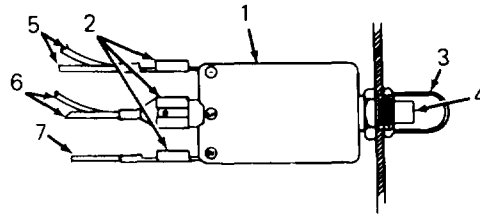

1. Disconnect violet wires (5), yellow wires (6), and grey wire (7) at quick disconnect terminals (2).
2. Unscrew seal boot (3) and pull RESET circuit breaker out of mounting hole from inside control box.

INSTALLATION:

1. Install RESET circuit breaker in mounting hole from inside control box.
2. Screw seal boot (3) onto circuit breaker and tighten securely.
3. Connect violet wires (5) to terminal 1, yellow wires (6) to terminal 3, and grey wire (7) to terminal 2.

INSPECT CONTROL BOX WIRING HARNESS

TEST EQUIPMENT: Volt ohmmeter

GENERAL SAFETY INSTRUCTIONS:

Power off.
Heater cool.

INSPECTION:

WARNING

Death or serious injury could occur if precautions are not taken when maintaining this equipment. Position HEATER-OFF-FAN switch to OFF, remove power cable plug from POWER RECEPTACLE, and ground capacitors C 1 and C 2 prior to gaining access to heater compartments. Terminals of capacitors are accessible at end cover of combustion blower. Always disconnect power cable before making continuity tests or before repairing heater. Always have another person standing by who is trained in electric shock first aid.

Allow sufficient time for heater to cool to room temperature before gaining access to heater compartments.

1. Check all leads (1) for cracked or burned insulation.
2. Check for broken or damaged terminals (2) on harness wires.
3. Check for secure connection to harness plug (3).
4. Check for broken soldered connections (4) at HEATER-OFF-FAN switch.
5. Check each harness wire for continuity.
6. Repair control box harness as needed.

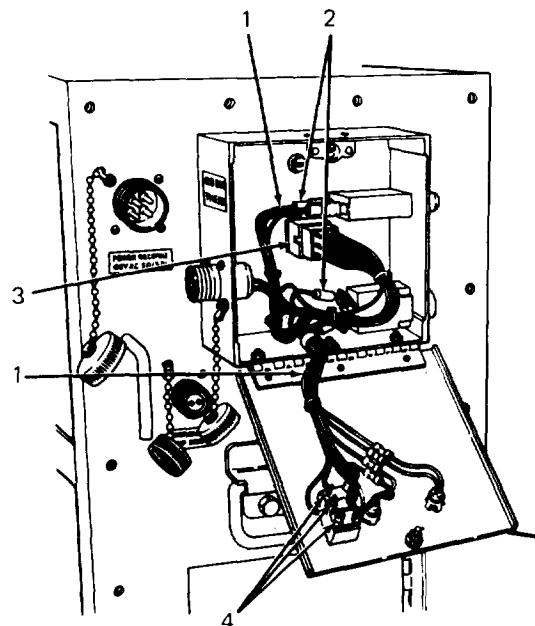

REPAIR CONTROL BOX HARNESS PLUG

TOOLS: Tool kit, service, refrigeration unit
NSN 5180-00-596-1474

MATERIALS/PARTS: Sealant (Item 10, Appendix E)
Tape (Item 14, Appendix E)
Control box harness plug
Female terminal (8)

GENERAL SAFETY INSTRUCTIONS:

Power off.
Heater cool.

REPAIR:

WARNING

Death or serious injury could occur if precautions are not taken when maintaining this equipment. Position HEATER-OFF-FAN switch to OFF, remove power cable plug from POWER RECEPTACLE, and ground capacitors C1 and C2 prior to gaining access to heater compartments. Terminals of capacitors are accessible at end cover of combustion blower. Always have another person standing by who is trained in electric shock first aid.

Allow sufficient time for heater to cool to room temperature before gaining access to heater compartments.

Control box harness wires are potted into control box harness plug. Repair consists of replacing plug. Control box harness wires are long enough to allow cutting close to the plug and installing new receptacle. Proceed as follows:

1. Open control box by unlocking stud (1).
2. Disconnect plug (2) from receptacle (3) at center of control box.
3. Tag and remove violet, yellow, and grey wires (4, 5, and 6) and disconnect them from RESET circuit breaker (7).
4. Remove screw (8), lock washers (9 and 10), and nut (11) attaching ground wire (12).
5. Remove four screws (13), lock washers (14), and nuts (15). One screw (13) also attaches chain (16) of dust cover (17). Retain chain and dust cover.
6. Pull room thermostat receptacle (18) out of mounting hole from inside control box, This will provide enough slack in the control box harness for replacing plug (2).

REPAIR CONTROL BOX HARNESS PLUG (CONT)

7. Tag harness wires (19) and cut as close to plug (2) as possible. Discard plug.
8. Strip 1/4 inch (6.35 mm) of insulation from end of each wire (19). Crimp new female terminal (20) on each wire.
9. Refer to table 3-4 and insert terminals (20) into numbered sockets in plug (2). Wire colors (original; see wiring diagram plate inside access door or refer to tags) and socket numbers must be in accordance with table 3-4.

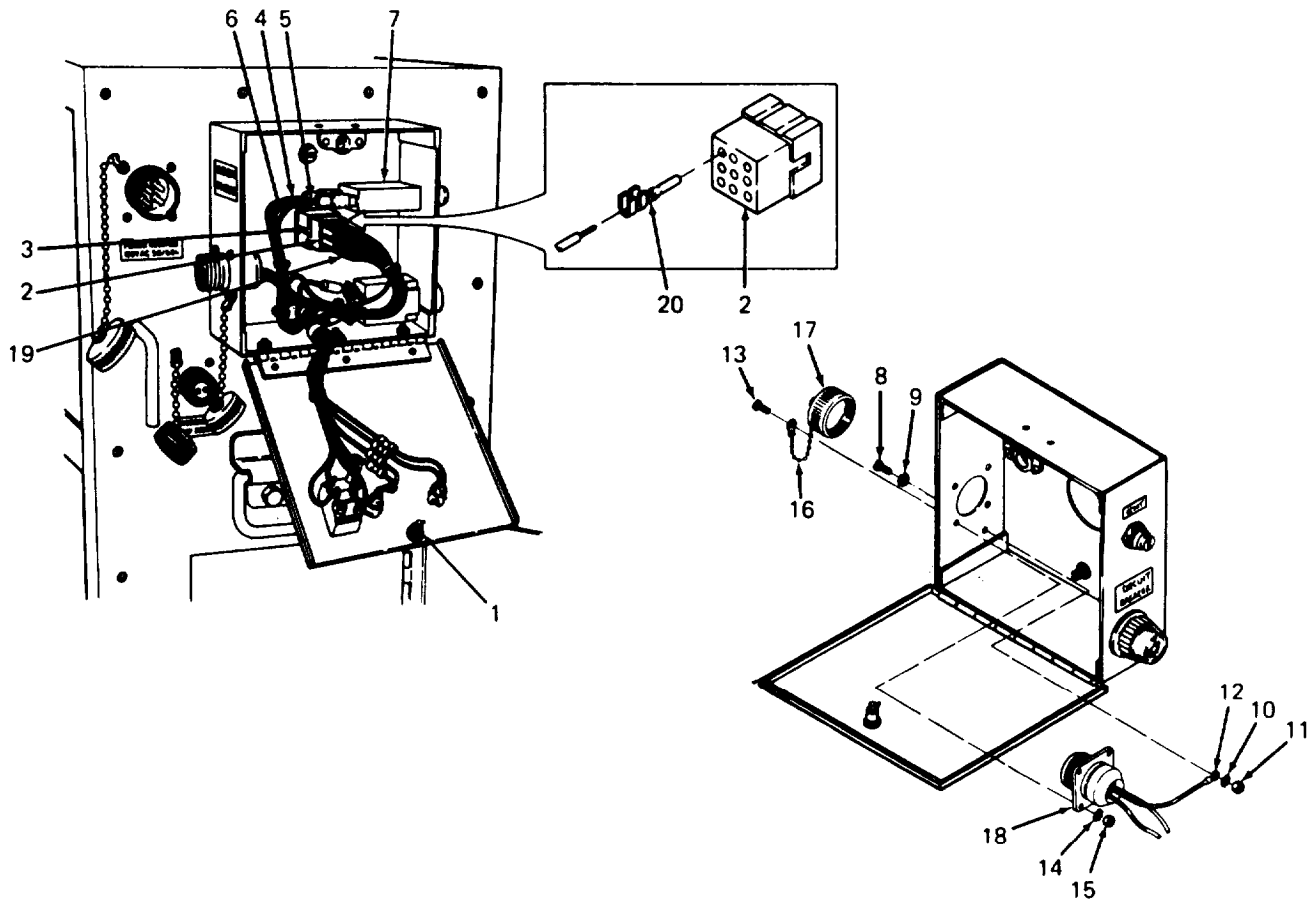

10. Make potting rim (21) around plug (2) using tape. Rim must project beyond plug around wires (19) 1/4 inch (6.35 mm) or more.
11. Fill rim with sealant and allow 8 hours to harden.
12. Position room thermostat receptacle (18) in mounting hole from inside control box.

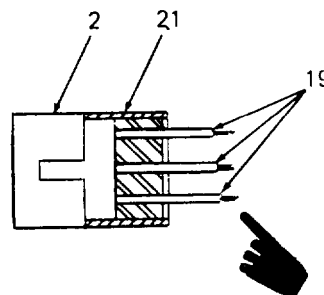

REPAIR CONTROL BOX HARNESS PLUG (CONT)

13. Secure room thermostat receptacle (18) with four screws (13), lock washers (14), and nuts (15).
Use one screw (13) to attach chain (16) of dust cover (17).
14. Attach ground wire (12) using screw (8), lock washers (9 and 10), and nut (11).
15. Connect wires (4, 5, and 6) to RESET circuit breaker as follows:
 - a. Connect violet wires to terminal number 1.
 - b. Connect yellow wires to terminal number 3
 - c. Connect grey wire to terminal number 2.
16. Connect plug (2) to receptacle (3).
17. Close control box and secure cover with stud (1).

Table 3-4. Plug Wiring Sequence

Wire Color	Socket No.
Black	1
Brown	2
Red	3
White	4
Yellow	5
Orange	6
Grey	7
Green	8
NOT USED	9

REPAIR WIRE TERMINALS

TOOLS: Tool kit, service, refrigeration unit
 NSN 5180-00-596-1747

MATERIALS/PARTS: Butt connector (4)

GENERAL SAFETY INSTRUCTIONS:

Power off.
 Heater cool.

EQUIPMENT CONDITION:

<u>Page</u>	<u>Condition Description</u>
3-39	Control box cover open,

REPAIR:



Death or serious injury could occur if precautions are not taken when maintaining this equipment. Position HEATER-OFF-FAN switch to OFF, remove power cable plug from POWER RECEPTACLE, and ground capacitors C1 and C2 prior to gaining access to heater compartments. Terminals of capacitors are accessible at end cover of combustion blower. Always disconnect power cable before making continuity tests or before repairing heater. Always have another person standing by who is trained in electric shock first aid.

Allow sufficient time for heater to cool to room temperature before gaining access to heater compartments.

1. Check butt connectors (1) for security. Replace loose butt connectors. Always use new butt connectors after disconnecting wire. Be sure 1/4 inch (6.35 mm) of good wire is stripped before installation.
2. Check ring tongue terminal (2) and ring terminals (3) for security, damage, and burning. Replace loose or damaged terminal. If damaged terminal is still firmly crimped to wire, cut wire close to terminal. Strip 3/8 inch (9.53 mm) of insulation and crimp on new terminal.
3. Check quick disconnect terminals (4) for security, damage, and burning. Be sure terminal makes firm contact with mating terminal. Replace loose, damaged, or poorly fitting terminals. If damaged terminal is still firmly crimped to wire, cut wire close to terminal. Strip 3/8 inch (9.53 mm) of insulation and crimp on new terminal.

REPAIR WIRE TERMINALS (CONT)

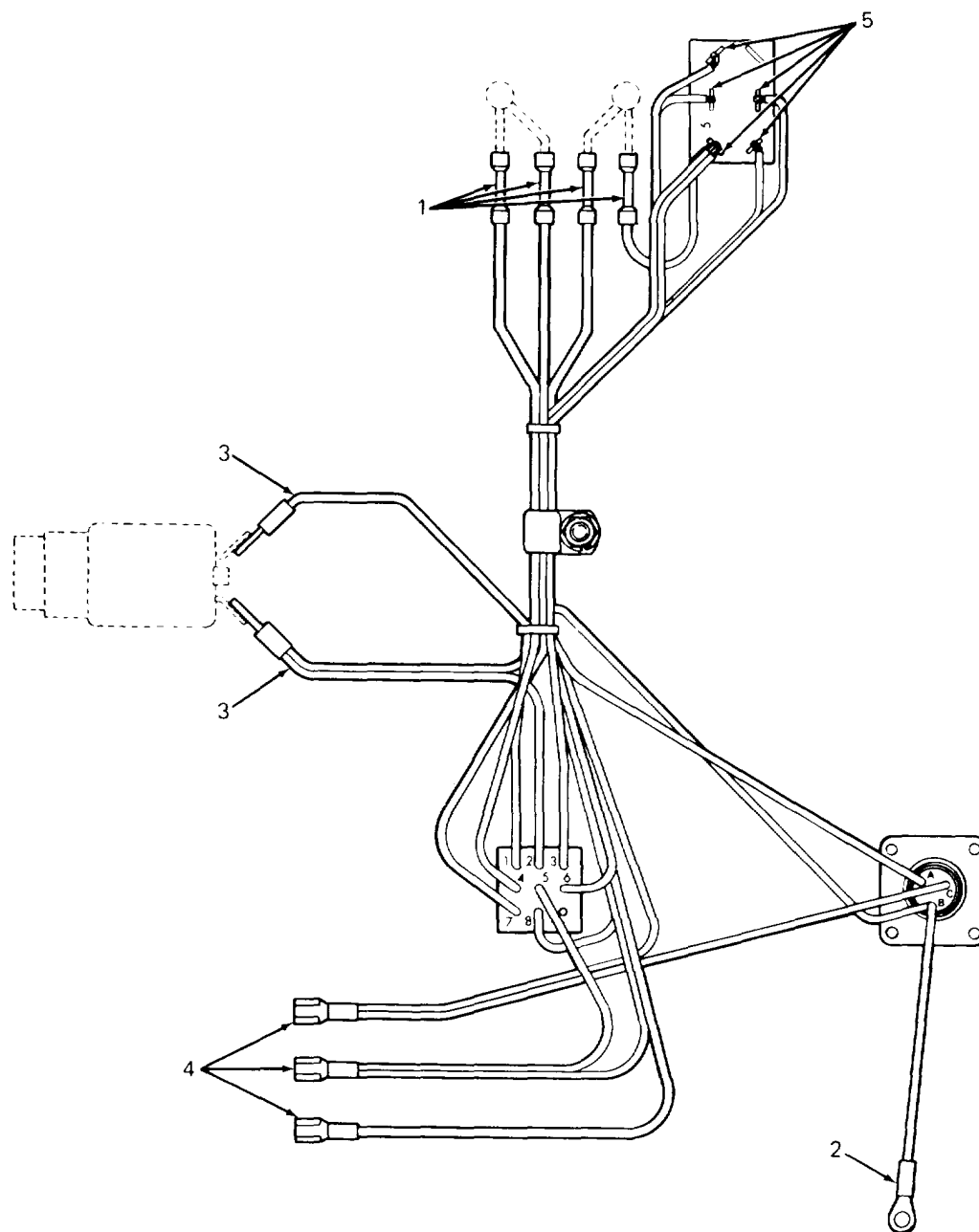

4. Check soldered wire ends (5) for weak or broken connections. Resolder where needed. Be sure 1/4 inch (6.35 mm) of good wire is stripped before soldering.

REPLACE CONTROL BOX HARNESS WIRES

TOOLS: Tool kit, service, refrigeration unit
NSN 5180-00-596-1474

MATERIALS/PARTS: Solder (Item 12, Appendix E)
Cable tie (2)

REFERENCES:

Page 3-39 INSPECT/REMOVE/INSTALL ROOM THERMOSTAT RECEPTACLE
Appendix F

EQUIPMENT CONDITION:

Page	<u>Condition Description</u>
3-39	Control box cover open.

GENERAL SAFETY INSTRUCTIONS:

Power off.
Heater cool.

REPLACEMENT:

Table 3-5 lists particulars for all of the control box harness wires. Table 3-6 lists only those wires which can be fabricated for replacement by unit maintenance. Opposite the index number of each replaceable wire in table 3-6 is the corresponding figure number in Appendix F and the appropriate action to be taken.

WARNING

Death or serious injury could occur if precautions are not taken when maintaining this equipment. Position HEATER-OFF-FAN switch to OFF, remove power cable plug from POWER RECEPTACLE, and ground capacitors C1 and C2 prior to gaining access to heater compartments. Terminals of capacitors are accessible at end cover of combustion blower. Always disconnect power cable before making continuity tests or before repairing heater. Always have another person standing by who is trained in electric shock first aid.

Allow sufficient time for heater to cool to room temperature before gaining access to heater compartments.

1. Cut two cable ties (17) and discard.
2. Release tension on harness clamp (18) by removing screw (19), lock washer (20), and nut (21).

REPLACE CONTROL BOX HARNESS WIRES (CONT)

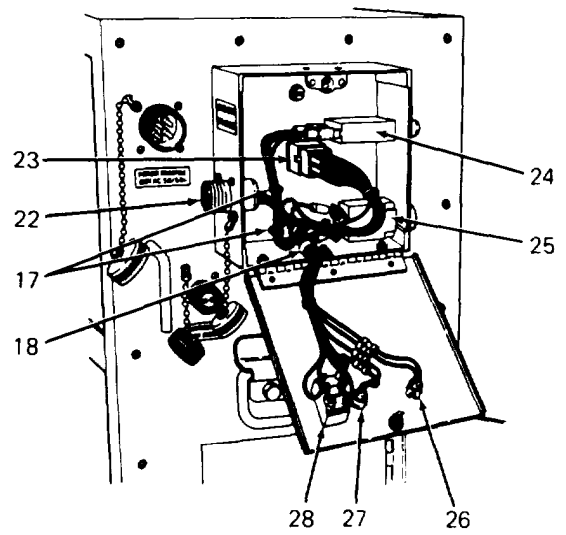
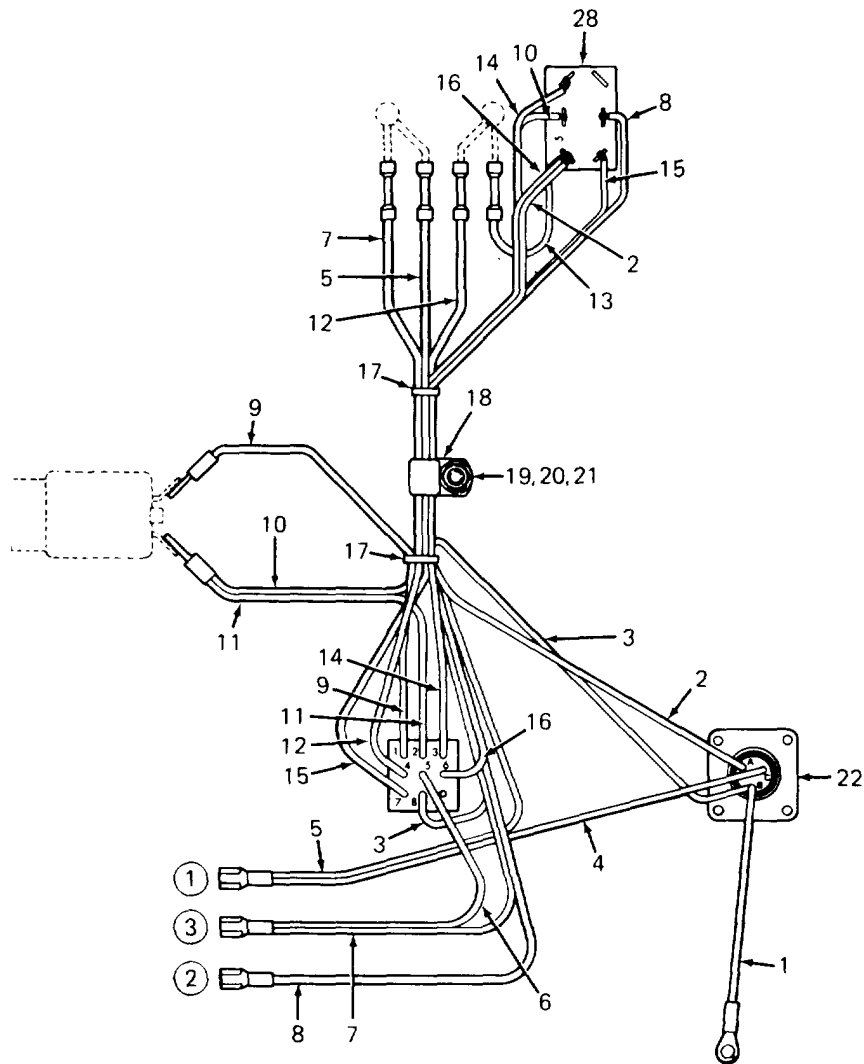

REPLACE CONTROL BOX HARNESS WIRES (CONT)

Table 3-5. Control Box Harness Wires

Wire Index No.	From	To	Color/ Wire Gauge	Inch (mm)
1	ROOM THERMO Receptacle B (22)	Ground	Green 20-gauge	3.0 (76.2)
2	ROOM THERMO Receptacle A (22)	HEATER-OFF-FAN Switch (28), FAN	Orange 16-gauge	9.5 (241.3)
3	ROOM THERMO Receptacle B (22)	Plug (Socket No. 8) (23)	Green 20-gauge	5.0 (127.0)
4	ROOM THERMO Receptacle C (22)	RESET Circuit Breaker, Contact No. 1	Violet 20-gauge	4.50 (114.3)
5	RESET Circuit Breaker (24) Contact No. 1	FAULT (Red) Light (26)	Violet 20-gauge	8.75 (222.3)
6	RESET Circuit Breaker (24) Contact No. 3	Plug (Socket No. 5) (23)	Yellow 16-gauge	6.75 (171.5)
7	RESET Circuit Breaker (24) Contact No. 3	FAULT (Red) Light (26)	Yellow 20-gauge	8.75 (222.3)
8	RESET Circuit Breaker (24) Contact No. 2	HEATER-OFF-FAN Switch (28), OFF	Grey 20-gauge	11.25 (285.8)
9	CIRCUIT BREAKER (25)	Plug (Socket No. 1) (23)	Black 16-gauge	5.00 (127.0)
10	CIRCUIT BREAKER (25)	HEATER-OFF-FAN Switch (28), OFF	Brown 16-gauge	8.00 (203.2)
11	CIRCUIT BREAKER (25)	Plug (Socket No. 2) (16)	Brown 16-gauge	5.00 (127.0)
12	HEAT (White) Light (27)	Plug (Socket No. 4) (23)	White 20-gauge	7.25 (184.2)
13	HEAT (White) Light (27)	HEATER-OFF-FAN Switch (28), FAN	Orange 20-gauge	2.00 (50.8)
14	HEATER-OFF-FAN Switch (28), HEATER	Plug (Socket No. 3) (23)	Red 16-gauge	10.75 (273.1)
15	HEATER-OFF-FAN Switch (28), FAN	Plug (Socket No. 7) (23)	Grey 20-gauge	9.75 (247.7)
16	HEATER-OFF-FAN Switch (28), FAN	Plug (Socket No. 6) (23)	Orange 20-gauge	9.50 (241.3)

REPLACE CONTROL BOX HARNESS WIRES (CONT)

3. Check wires for cracked, burned, or abraded insulation and replace as needed. Disconnect at least one end of any wire indicating open circuit and test for continuity. Replace if circuit is open.
4. Replace harness wire as follows:
 - a. Replace one wire at a time. Otherwise, old wires must be tagged and retained until new wire is installed.
 - b. Refer to appropriate figure in Appendix F and fabricate wire.
 - c. Install new wire between components in accordance with table 3-5. Be sure new wire is under harness clamp (18). When connecting wires with butt connectors, always use new connectors.
 - d. Secure harness clamp (18) using screw (19), lock washer (20), and nut (21).
 - e. Bind harness wires using two cable ties (17).

Table 3-6. Fabricated Control Box Harness Wires

Wire Index No.	Appendix F Fig. No.	Action
1	10	Refer to INSPECT/REMOVE/INSTALL ROOM THERMOSTAT RECEPTACLE, page 3-39.
2	9	Refer to INSPECT/REMOVE/INSTALL ROOM THERMOSTAT RECEPTACLE, page 3-39.
4	11	Refer to INSPECT/REMOVE/INSTALL ROOM THERMOSTAT RECEPTACLE, page 3-39.
5	4	Fabricate/Install
7	3	Fabricate/Install
8	2	Fabricate/Install
10	1	Fabricate/Install
13	5	Fabricate/Install

INSPECT/TEST/REMOVE/INSTALL HEATER-OFF-FAN SWITCH

TEST EQUIPMENT: Volt ohmmeter

TOOLS: Tool kit, service, refrigeration unit
NSN 5180-00-596-1474

Solder gun kit
NSN 3439-00-930-1638

MATERIALS/PARTS: Solder (Item 12, Appendix E)

GENERAL SAFETY INSTRUCTIONS:

Power off.

INSPECTION:

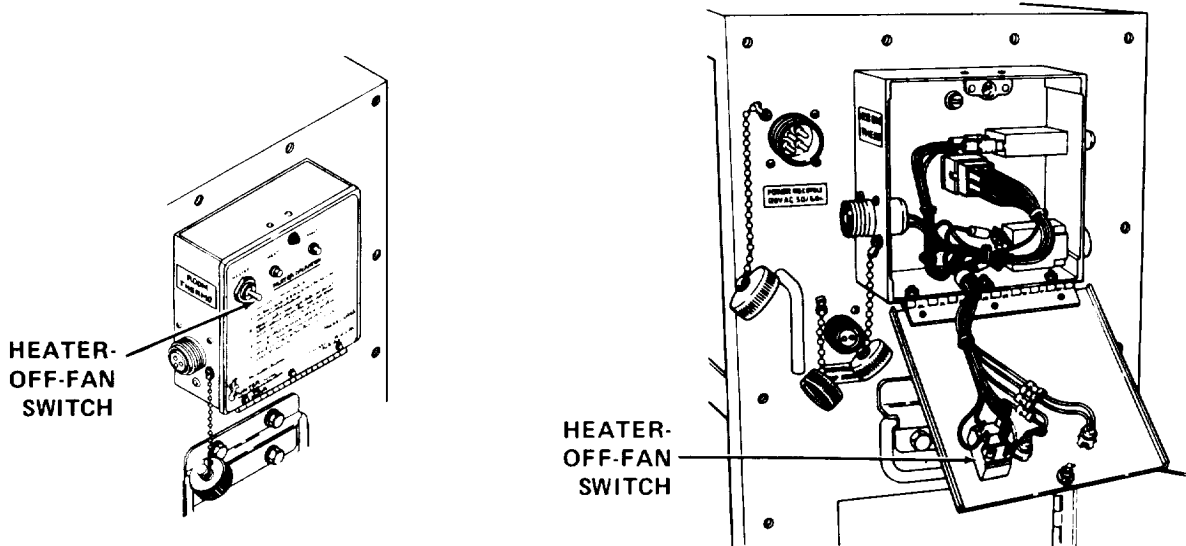

1. Operate HEATER-OFF-FAN switch. Be sure switch snaps firmly into all operating positions.

WARNING

Death or serious injury could occur if precautions are not taken when maintaining this equipment. Position HEATER-OFF-FAN switch to OFF, remove power cable plug from POWER RECEPTACLE, and ground capacitors C1 and C2 at end cover of combustion blower. Always have another person standing by who is trained in electric shock first aid.

2. Open control box and examine for damage to switch body or terminals. Replace defective switch.

INSPECT/TEST/REMOVE/INSTALL HEATER-OFF-FAN SWITCH (CONT)

TESTING:

1. Disconnect power cable and open control box. HEATER-OFF-FAN switch will appear as illustrated.
2. Check switch for continuity as follows:
 - a. Between terminals 6 and 1, switch in FAN position.
 - b. Between terminals 3 and 2, switch in FAN position.
 - c. Between terminals 3 and 4, switch in HEATER position.

Terminal 5 is not used in this application.

3. There must be no continuity between terminals 6 and 1, 3 and 2, or 3 and 4 when HEATER-OFF-FAN switch is in OFF position.
4. If HEATER-OFF-FAN switch fails any of above tests, replace switch.

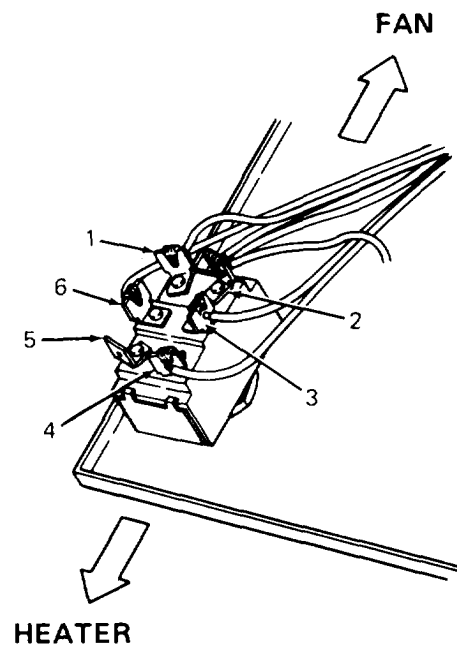

INSPECT/TEST/REMOVE/INSTALL HEATER-OFF-FAN SWITCH (CONT)

REMOVAL:

Complete removal of the HEATER-OFF-FAN switch is necessary only when replacing a defective switch. If removed from the control box cover for any other purpose, do not disconnect wires.

1. Remove hex nut at front of control box cover and pull HEATER-OFF-Fan switch out of mounting hole from back cover.

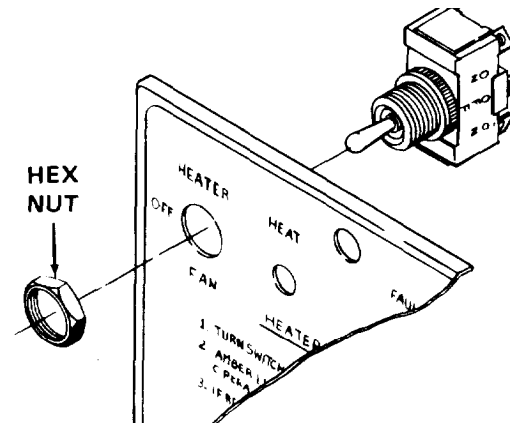

NOTE

Tag wires carefully before disconnecting. Different wires of the same color are connected to the HEATER-OFF-FAN switch.

2. Tag wires and cut as close to switch terminals (1, 3, 4, 5, and 6) as possible. Wire numbers are the same as those appearing table 3-5.

INSTALLATION:

1. Install new HEATER-OFF-FAN switch in mounting hole of control box cover. Insert switch from back of cover.

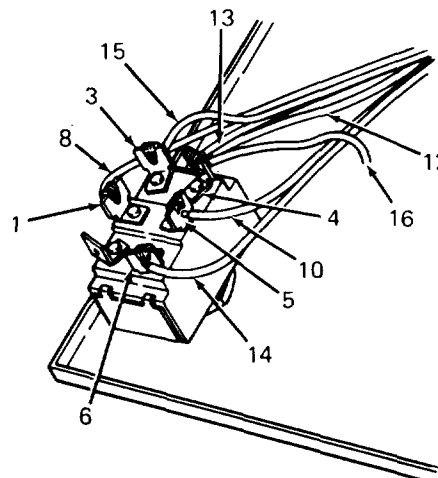

NOTE

Illustration shows HEATER-OFF-FAN switch as it appears to technician standing in front of control box with cover open. Note position of numeral 5 on bottom of switch.

2. Position HEATER-OFF-FAN switch as illustrated and secure with hex nut at front of control box cover.
3. Strip 1/4 inch (6.35 mm) of insulation from the cut end of each wire. Solder wires to terminals in accordance with tags. If in doubt as to location of any wire, find wire number in table 3-5 and check From/To columns.

REMOVE/INSTALL HEAT AND FAULT LIGHTS

TOOLS: Tool kit, service, refrigeration unit
NSN 5180-00-596-1474

Solder gun kit
NSN 3439-00-930-1638

MATERIALS/PARTS: Solder (Item 12, Appendix E)
L.E.D. FAULT light (red)
L.E.D. HEAT light (white)
Butt connector (4)

GENERAL SAFETY INSTRUCTIONS:

Power off.
Heater cool.

REMOVAL:

WARNING

Death or serious injury could occur if precautions are not taken when maintaining this equipment. Position HEATER-OFF-FAN switch to OFF, remove power cable plug from POWER RECEPTACLE, and ground capacitors C1 and C2 prior to gaining access to heater compartments. Terminals of capacitors are accessible at end cover of combustion blower. Always disconnect power cable before making continuity tests or before repairing heater. Always have another person standing by who is trained in electric shock first aid.

Allow sufficient time for heater to cool to room temperature before gaining access to heater compartments.

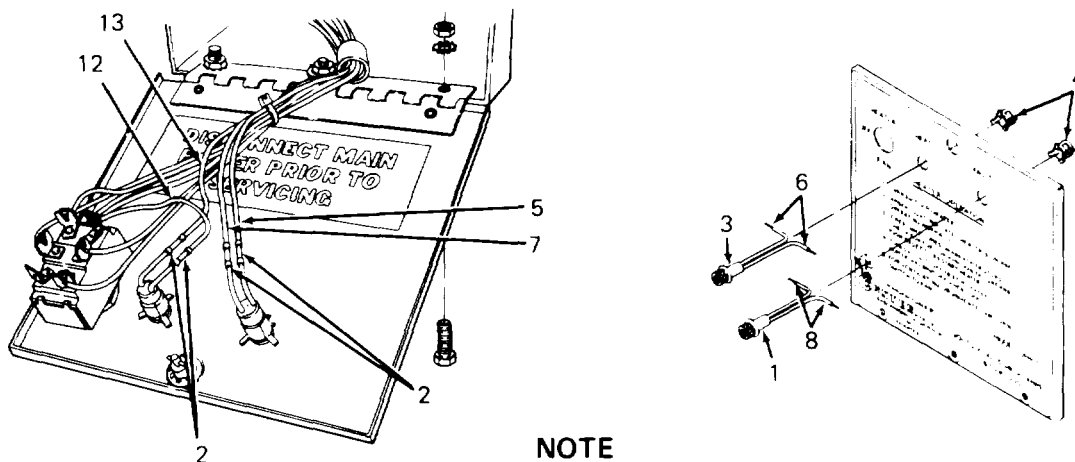

NOTE

HEAT or FAULT light will normally be removed for replacement only. Barrel fastener (4) will be destroyed during removal. New barrel fastener accompanies new light.

REMOVE/INSTALL HEAT AND FAULT LIGHTS (CONT)

1. To remove FAULT light (1), locate violet and yellow wires (5 and 7). Wire numbers are same as those appearing in table 3-5. Disconnect wires at butt connectors (2). Discard butt connectors. Proceed to step 3.
2. To remove HEAT light (3), locate white and orange wires (12 and 13). Wire numbers are same as those appearing in table 3-5. Disconnect wires at butt connectors (2). Discard butt connectors.
3. Grasp barrel fastener (4) with pliers and forcibly remove. Discard fastener.
4. Pull FAULT or HEAT light out of mounting hole from front of control box cover.

INSTALLATION:

1. Thread wires of FAULT or HEAT light through mounting hole from front of control box cover. Seat light in mounting hole.
2. Secure light with barrel fastener (4).
3. Leads (6) of HEAT light and leads (8) of FAULT light must have 1/4 inch (6.35 mm) of insulation stripped from ends.
4. Connect leads (6) of HEAT light to white and orange wires (12 and 13). Use new butt connectors (2).
5. Connect leads (8) of FAULT light to violet and yellow wires (5 and 7). Use new butt connectors (2).
6. If in doubt as to location of any wire, find wire number in table 3-5 and check From/To columns.

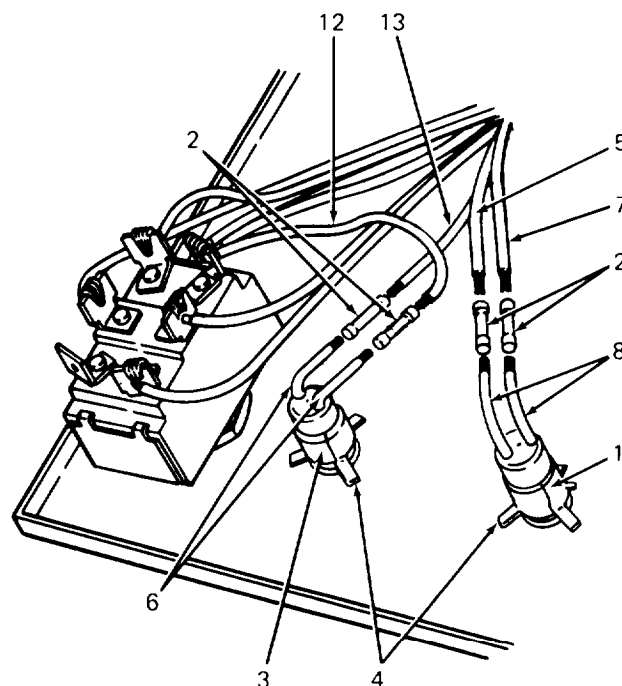

INSPECT/REMOVE/INSTALL POWER RECEPTACLE AND EXTERNAL FUEL PUMP RECEPTACLE

TOOLS: Tool kit, service, refrigeration unit
NSN 5180-00-596-1474

Solder gun kit
NSN 3439-00-930-1638

MATERIALS/PARTS: Sealant (Item 10, Appendix E)
Solder (Item 12, Appendix E)
Tape (Item 14, Appendix E)

GENERAL SAFETY INSTRUCTIONS:

Power off.
Heater cool.

INSPECTION:

WARNING

Death or serious injury could occur if precautions are not taken when maintaining this equipment. Position HEATER-OFF-FAN switch to OFF, remove power cable plug from POWER RECEPTACLE, and ground capacitors C1 and C2 prior to gaining access to heater compartments. Terminals of capacitors are accessible at end cover of combustion blower. Always disconnect power cable before making continuity tests or before repairing heater. Always have another person standing by who is trained in electric shock first aid.

Allow sufficient time for heater to cool to room temperature before gaining access to heater compartments.

1. Check for presence of dust caps (1 and 3) and chains (2 and 4).
2. Check threads on POWER RECEPTACLE (5), EXTERNAL FUEL PUMP RECEPTACLE (6), and inside dust caps (1 and 3) for stripping and crossing.
3. Carefully inspect both receptacles for signs of arcing, burning, or other damage.

WARNING

Death or serious injury could occur if precautions are not taken when maintaining this equipment. Position HEATER-OFF-FAN switch to OFF, remove power cable plug from POWER RECEPTACLE, and ground capacitors C1 and C2 at end cover of combustion blower. Always have another person standing by who is trained in electric shock first aid.

4. Remove six screws (7) and lock washers (8). Lift off bottom cover (9).

INSPECT/REMOVE/INSTALL POWER RECEPTACLE AND EXTERNAL FUEL PUMP RECEPTACLE (CONT)

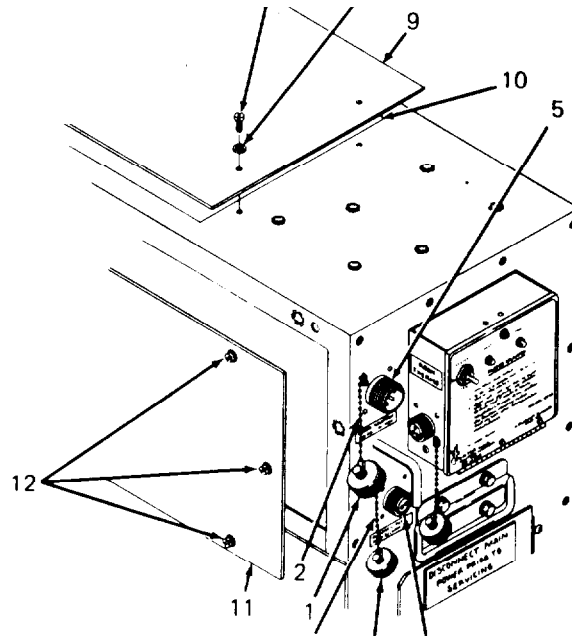

5. Reach through heater case opening (10) and disconnect louver linkage from louver.
6. Remove louver panel(11) by unlocking eight studs (12).
7. Check for damage to POWER RECEPTACLE (5) and EXTERNAL FUEL PUMP RECEPTACLE (6) inside heater case. Replace defective receptacle.

NOTE

For Model UH-68G, wires connected to POWER RECEPTACLE and EXTERNAL FUEL PUMP RECEPTACLE are potted to the receptacles. To remove a receptacle, wires must be cut and receptacle replaced. Pot wires to new receptacle.

For Model UH-68G1, wires connected to POWER RECEPTACLE and EXTERNAL FUEL PUMP RECEPTACLE are soldered and mechanically sealed to the receptacles. To remove a receptacle, receptacle must be disassembled, wires must be cut or unsoldered, and receptacle replaced.

REMOVAL:

1. Remove POWER RECEPTACLE as follows:
 - a. Remove four screws (1), lock washers (2), and nuts (3). Pull POWER RECEPTACLE (4) out of mounting hole from inside heater case.

INSPECT/REMOVE/INSTALL POWER RECEPTACLE AND EXTERNAL FUEL PUMP RECEPTACLE (CONT)

- b. For Model UH-68G1, unscrew endbell (4.1) from POWER RECEPTACLE (4) and slide it back over the wires (5, 6, and 7). Pull back ferrule (4.2) and grommet (4.3) to expose soldered ends of the wires.
- c. Tag black and white wires (5 and 6) and ground (green) wire (7). Cut wires as close to POWER RECEPTACLE as possible.

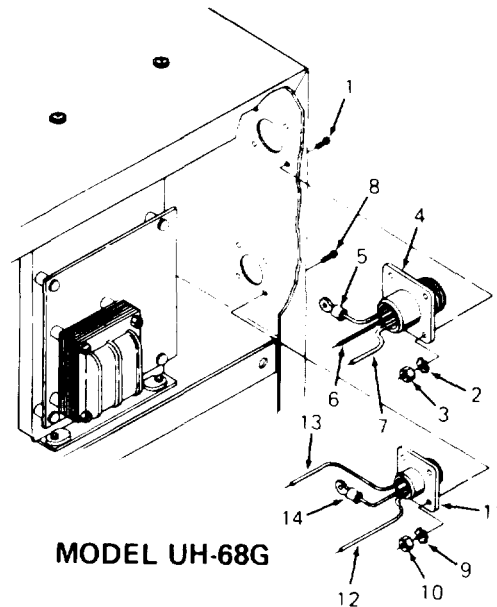

MODEL UH-68G

- 2. Remove EXTERNAL FUEL PUMP RECEPTACLE as follows:
 - a. Remove four screws (8), lock washers (9), and nuts (10). Pull EXTERNAL FUEL PUMP RECEPTACLE (11) out of mounting hole from inside heater case.
 - b. For Model UH-68G1, unscrew endbell (11.1) from EXTERNAL FUEL PUMP RECEPTACLE (11) and slide it back over the wires (12, 13, and 14). Pull back ferrule (11.2) and grommet (11.3) to expose soldered ends of the wires.
 - c. Tag green and blue wires (12 and 13) and ground (green) wire (14). Cut wires as close to EXTERNAL FUEL PUMP RECEPTACLE as possible.

INSTALLATION:

- 1. Prepare EXTERNAL FUEL PUMP RECEPTACLE (11) as follows:

- a. Strip 1/4 inch (6.35 mm) of insulation from cut ends of green and blue wires (12 and 13) and ground (green) wire (14).
- b. For Model UH-68G1, thread wires (12, 13, and 14) through end bell (11.1) and ferrule (11.2). Thread the stripped end of each wire through grommet (11.3) as follows:
 - (1) Slide blue wire (13) through grommet (11.3) opening A.
 - (2) Slide green wire (12) and ground (green) wire (14) through opening B.
- c. Solder wires (12, 13, and 14) to receptacle terminals as follows:
 - (1) Green wire (12) to terminal B.
 - (2) Blue wire (13) to terminal A.
 - (3) Ground (green) wire (14) to terminal B.

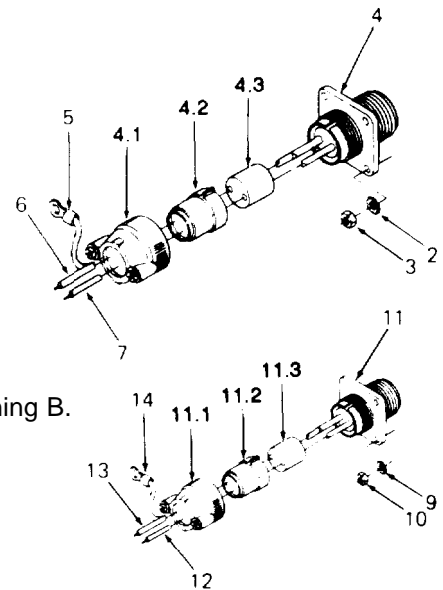

MODEL UH-68G1

- d. For Model UH-68G, pot wires as described in step 3, following.
- e. For Model UH-68G1, push grommet (11.3) into rear of receptacle (11), seat ferrule (11.2) over grommet, and tighten endbell (11.1) to threads on rear of receptacle.

INSPECT/REMOVE/INSTALL POWER RECEPTACLE AND EXTERNAL FUEL PUMP RECEPTACLE (CONT)

2. Prepare POWER RECEPTACLE (4) as follows:

- a. Strip 1/4 inch (6.35 mm) of insulation from cut ends of black and white wires (5 and 6) and ground (green) wire (7).
- b. For Model UH-68G1, thread wires (5, 6, and 7) through endbell (4.1) and ferrule (4.2). Thread the stripped end of each wire through grommet (4.3) as follows:
 - (1) Slide black wire (5) through opening A of grommet (4.3).
 - (2) Slide white wire (6) through opening C of grommet.
 - (3) Slide ground (green) wire (7) through opening D of grommet.
- c. Solder wires (5, 6, and 7) to receptacle terminals as follows:
 - (1) Black wire (5) to terminal A.
 - (2) White wire (6) to terminal C.
 - (3) Ground (green) wire (7) to terminal D.
- d. For Model UH-68G, pot wires as described in step 3, following.
- e. For Model UH-68G1, push grommet (4.3) into rear of receptacle (4), seat ferrule (4.2) over grommet, and tighten endbell (4.1) to threads on rear of receptacle.

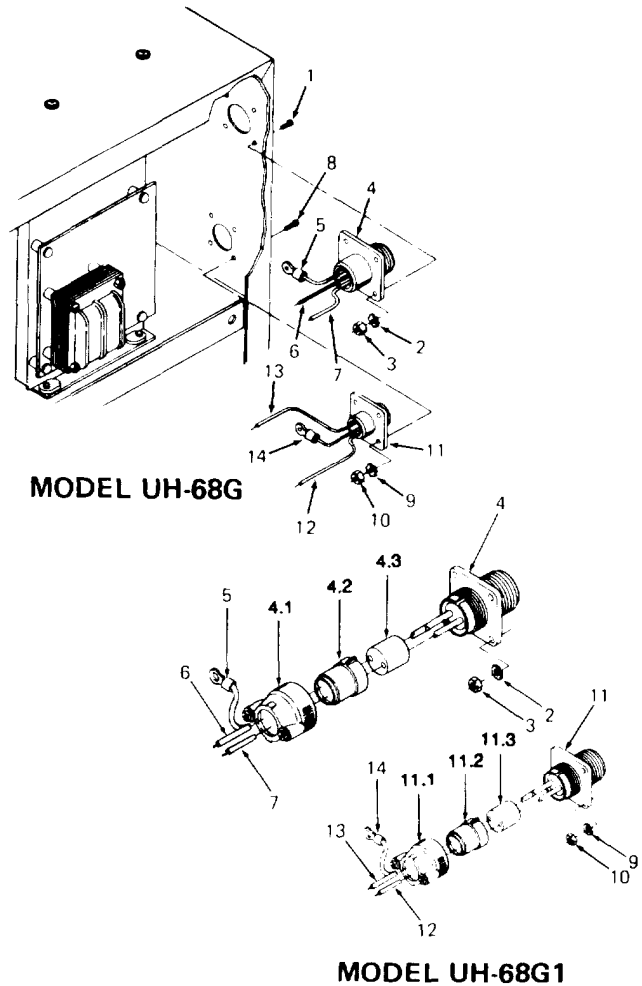

3. For Model UH-68G, the procedure for potting wires to POWER RECEPTACLE and EXTERNAL FUEL RECEPTACLE is the same for both receptacles. Proceed as follows:

- a. Make potting rim around receptacle using tape. Rim must project beyond receptacle around wires 1/4 inch (6.35 mm) or more.
- b. Fill rim with sealant and allow 8 hours to cure.

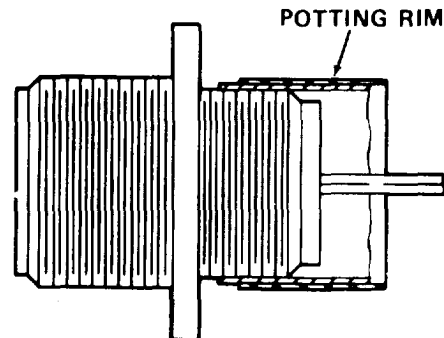

4. Install EXTERNAL FUEL PUMP RECEPTACLE (11) in mounting hole from inside heater case. Secure receptacle using four screws (8), lock washers (9), and nuts (10). Attach terminal end of ground wire (14) to one screw/lock washer/nut combination during this step.

INSPECT/REMOVE/INSTALL POWER RECEPTACLE AND EXTERNAL FUEL PUMP RECEPTACLE (CONT)

5. Install POWER RECEPTACLE (4) in mounting hole from inside heater case. Secure receptacle using four screws (1), lock washers (2), and nuts (3). Attach terminal end of ground wire (7) to one screw/lock washer/nut combination during this step.
6. Install louver panel (11) by locking eight studs (12).
7. Reach through heater case opening (10) and connect louver linkage to louver.
6. Install bottom cover (9) using six screws (7) and lock washers (8).

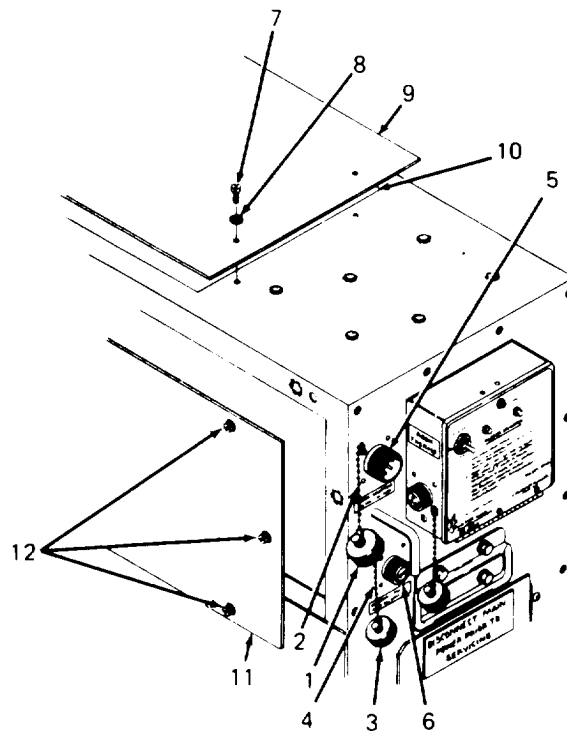

INSPECT PRINTED CIRCUIT (PC) BOARD ASSEMBLY**GENERAL SAFETY INSTRUCTIONS:**

Power off.
Heater cool.

INSPECTION:**W A R N I N G**

Death or serious injury could occur if precautions are not taken when maintaining this equipment. Position HEATER-OFF-FAN switch to OFF, remove power cable plug from POWER RECEPTACLE, and ground capacitors C1 and C2 prior to gaining access to heater Compartments. Terminals of capacitors are accessible at end cover of combustion blower. Always have another person standing by who is trained in electric shock first aid.

Allow sufficient time for heater to cool to room temperature before gaining access to heater compartments.

1. Check for secure mounting of PC board assembly (1).
2. Check PC board assembly (1) for breaks, cracks, or bare portions in potting.
3. Trace each wire of PC board assembly (2). Check for damaged insulation, loose or missing terminals, and loose or missing cable ties.
4. On Model UH-68G, check for loose wires and damaged potting at POWER RECEPTACLE (3) and EXTERNAL FUEL PUMP RECEPTACLE (4).
5. On Model UH-68G1, check for loose wires and damaged solder joints at POWER RECEPTACLE (3) and EXTERNAL FUEL PUMP RECEPTACLE (4).
6. Check PC board assembly receptacle (5) for loose wires and damaged potting.
7. On Model UH-68G1, check harness receptacle (6) and plug (7) for loose wires and damaged potting.
8. If PC board assembly does not pass above inspections, forward heater to intermediate maintenance for repair or replacement.

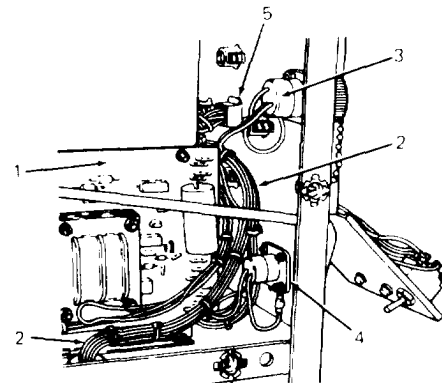
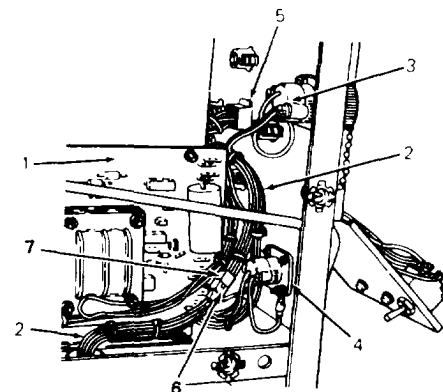
**MODEL UH-68G****MODEL UH-68G1**

HEATER CASE ASSEMBLY PROCEDURES INDEX

PROCEDURE	PAGE
Inspect/Service Heater Case Assembly	3-66
Adjust/Inspect/Service/Remove/install Side Panels and Louver Linkage	3-71
Adjust/Inspect/Service/Remove/install Doors and Bottom Cover	3-76
Inspect/Remove/Install Data Plates	3-80
Inspect/Remove/Install Labels	3-84

INSPECT/SERVICE HEATER CASE ASSEMBLY

TOOLS: Tool kit, service, refrigeration unit
 NSN 5180-00-596-1474

MATERIALS/PARTS: Antiseize compound (Item 1, Appendix E)
 Dry cleaning solvent (Item 13, Appendix E)

GENERAL SAFETY INSTRUCTIONS:

Power off.
 Heater cool.

INSPECTION:

WARNING

Death or serious injury could occur if precautions are not taken when maintaining this equipment. Position HEATER-OFF-FAN switch to OFF, remove power cable plug from POWER RECEPTACLE, and ground capacitors C1 and C2 prior to gaining access to heater compartments. Terminals of capacitors are accessible at end cover of combustion blower. Always have another person standing by who is trained in electric shock first aid.

Remove electrical charge from ventilating air motor capacitor C3 by shorting out contacts using tool having insulated handle.

Allow sufficient time for heater to cool to room temperature before gaining access to heater compartments.

1. Prepare heater case assembly for inspection as follows:
 - a. Open left door (1), front access door (2), and right door (3), Each door is released by unlocking one stud (4).

INSPECT/SERVICE HEATER CASE ASSEMBLY (CONT)

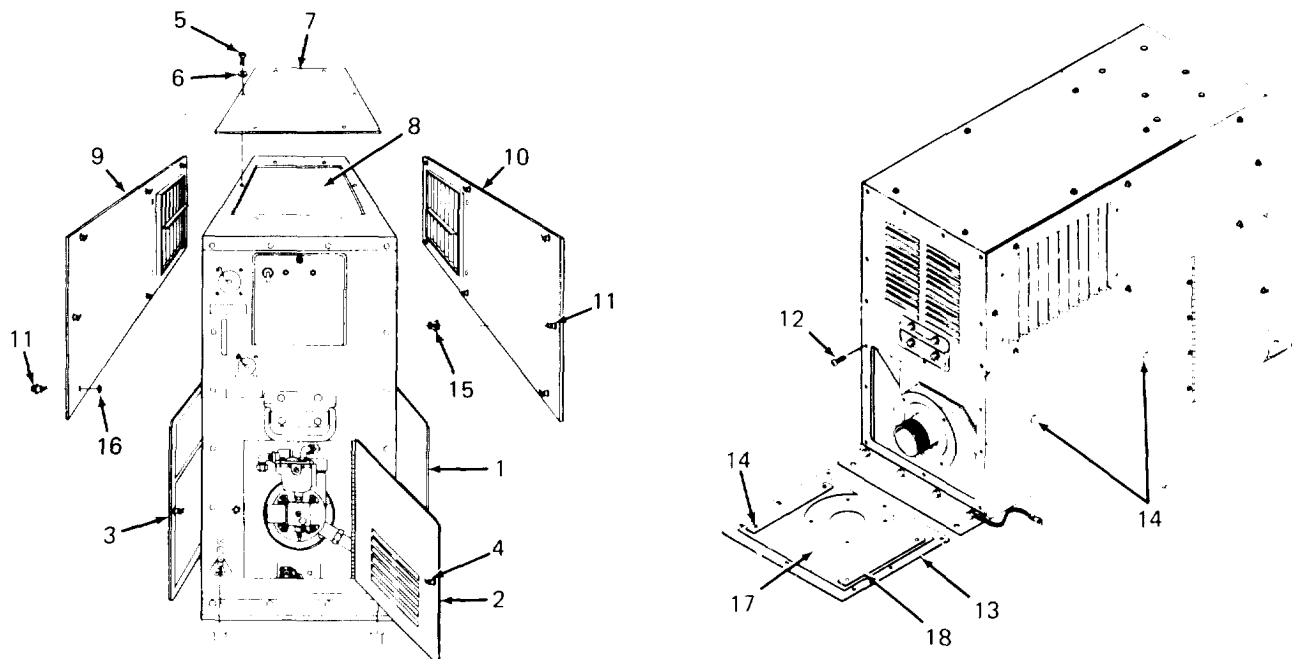

- b. Remove six screws (5) and lock washers (6) and lift off bottom cover (7).
 - c. Reach through heater case opening (8) and disconnect louver linkages from louvers.
 - d. Remove right-hand and left-hand louver panels (9 and 10) by unlocking eight studs (11) at each panel.
 - e. At exhaust end of heater case, remove eight screws (12) and lift off rear cover (13).
2. Examine heater case for surface rust and scratches.
 3. Check for missing or damaged hardware including rivets (14), studs (11), and stud receptacles (15). Replace as needed. To replace stud (11), remove solid washer (16). Install new stud and press on new washer.
 4. Check for dents, frame distortion, and broken welds.
 5. Check fixed louvers at rear of heater for obstructions. Be sure air can circulate freely through the louvers.
 6. Check shield (17) and straps (18) for security. The shield and straps are held by rivets (14).

INSPECT/SERVICE HEATER CASE ASSEMBLY (CONT)

7. Look through opening in rear of heater and check shields (1) and shield retainers (2) on either side of heat exchanger.

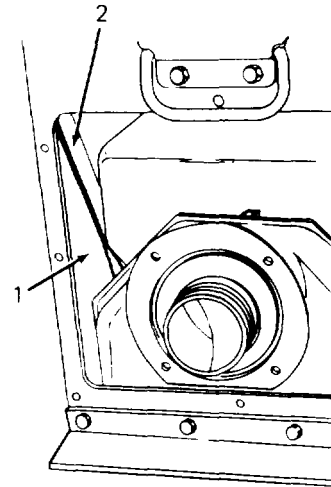

8. Check bulkhead for security.

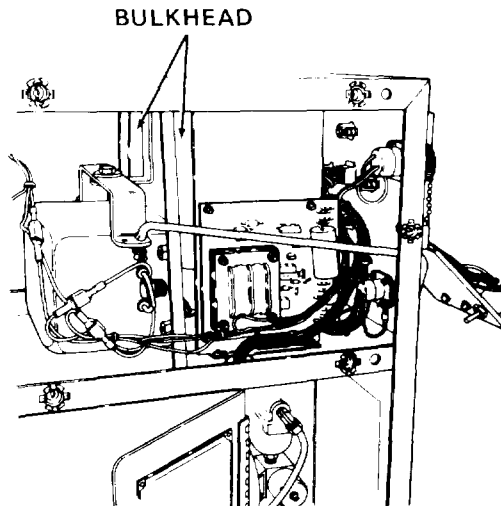

9. If heater case assembly needs painting or other repair, forward heater to intermediate maintenance.
10. Reassemble heater case assembly as follows:
 - a. Install rear cover (13) using eight screws (12).
 - b. Install louver panels (9 and 10) by locking eight studs (11) at each panel.
 - c. Reach through heater case opening (8) and connect louver linkages to louvers.
 - d. Install bottom cover (7) using six screws (5) and lock washers (6).
 - e. Close and lock doors (1, 2, and 3).

INSPECT/SERVICE HEATER CASE ASSEMBLY (CONT)

SERVICING:

WARNING

Dry cleaning solvent P-D-680 (safety or Stoddard's Solvent) is potentially dangerous. Avoid repeated and prolonged breathing of vapors and skin contact with the liquid. Do not use near open flame, arcing equipment, or other ignition sources. Always wear eye protection and protective clothing. Flash point of P-D-680 is 100° to 138° F (38° to 59°C).

Death or serious injury could occur if compressed air is directed against the skin. Do not use compressed air for cleaning or drying unless the pressure is/has been reduced to 30 psi (207 kPa) or less. When working with compressed air always use chip guards, eye protection, and other personal protective equipment.

Death or serious injury could occur if precautions are not taken when maintaining this equipment. Position HEATER-OFF-FAN switch to OFF, remove power cable plug from POWER RECEPTACLE, and ground capacitors C1 and C2 prior to gaining access to heater compartments. Terminals of capacitors are accessible at end cover of combustion blower. Always disconnect power cable before making continuity tests or before repairing heater. Always have another person standing by who is trained in electric shock first aid.

Remove electrical charge from ventilating air motor capacitor C3 by shorting out contacts using tool having insulated handle.

Allow sufficient time for heater to cool to room temperature before gaining access to heater compartments.

1. Remove grease, oil, and fuel deposits by wiping heater case with rags dampened with P-D-680 dry cleaning solvent. Remove excess dry cleaning solvent and dry with compressed air.
2. Remove six screws (1) and lock washers (2). Lift off bottom cover (3).
3. Reach through heater case opening (4) and disconnect louver linkages from louvers.
4. Remove louver panels (5 and 6) by unlocking eight studs (7) at each panel.
5. Clean and inspect interior including combustion blower and ventilating air motor.

INSPECT/SERVICE HEATER CASE ASSEMBLY (CONT)

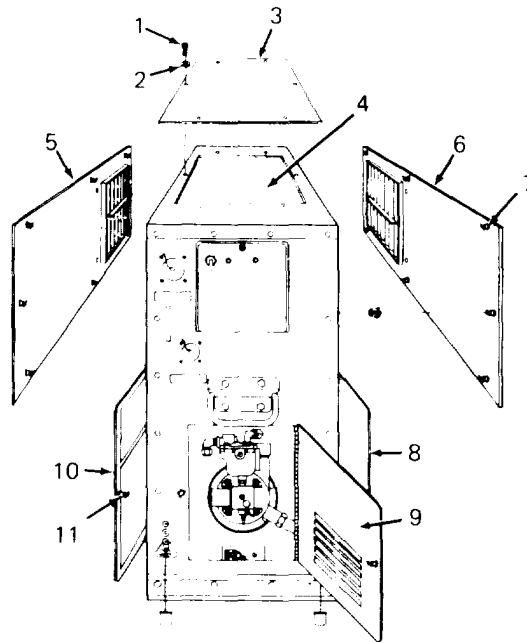

6. Open left heater case door (8), front access door (9), and right heater case door (10). Each door is released by unlocking one stud (11). Clean and inspect interior of heater. Lubricate door hinges with antiseize compound.
7. Close right heater case door (10), front access door (9), and left heater case door (8). Secure each door by locking one stud (11).
8. Install louver panels (5 and 6) by locking eight studs (7) at each panel.
9. Reach through heater case opening (4) and connect louver linkages to louvers.
10. Install bottom cover (3) using six screws (1) and lock washers (2).

ADJUST/INSPECT/SERVICE/REMOVE/INSTALL SIDE PANELS AND LOUVER LINKAGE

TOOLS: Tool kit, service, refrigeration unit
NSN 5180-00-596-1474

MATERIALS/PARTS: Antiseize compound (Item 1, Appendix E)
Dry cleaning solvent (Item 13, Appendix E)

GENERAL SAFETY INSTRUCTIONS:

Power off.
Heater cool.

ADJUSTMENT:

WARNING

Death or serious injury could occur if precautions are not taken when maintaining this equipment. Position HEATER-OFF-FAN switch to OFF, remove power cable plug from POWER RECEPTACLE, and ground capacitors C1 and C2 prior to gaining access to heater compartments. Terminals of capacitors are accessible at end cover of combustion blower. Always have another person standing by who is trained in electric shock first aid.

Remove electrical charge from ventilating air motor capacitor C3 by shorting out contacts using tool having insulated handle.

Allow sufficient time for heater to cool to room temperature before gaining access to heater compartments.

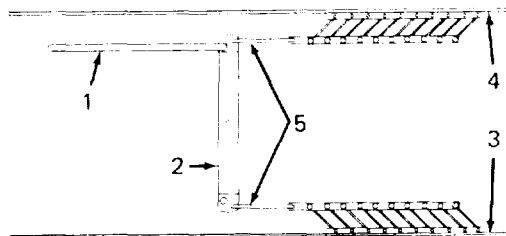

1. Side panel louvers are adjusted by a push-pull movement of louver handle (1). When louver handle is pushed in, pivot bar (2) turns clockwise to open louvers of right-hand louver panel (3) and close louvers of left-hand louver panel (4). Pulling on louver handle has opposite effect.
2. There is no adjustment within the linkage itself. Bent or distorted louver handle (1), pivot bar (2), or louver linkage (5) can cause binding and improper louver action. Distorted parts must be straightened or replaced to restore proper adjustment.

ADJUST/INSPECT/SERVICE/REMOVE/INSTALL SIDE PANELS AND LOUVER LINKAGE (CONT)

INSPECTION:

1. Remove six screws (1) and lock washers (2) and lift off bottom cover (3).
2. Observe through heater opening (4) and operate louver handle (5). Louvers (6) of side louver panels should open and close smoothly without binding at any point.
3. Check for broken pivots, disconnected linkage, and corrosion or distortion of parts. Replace defective parts. If louvers (6) are defective, replace louver panel.
4. If louver panel needs painting, forward to intermediate maintenance.

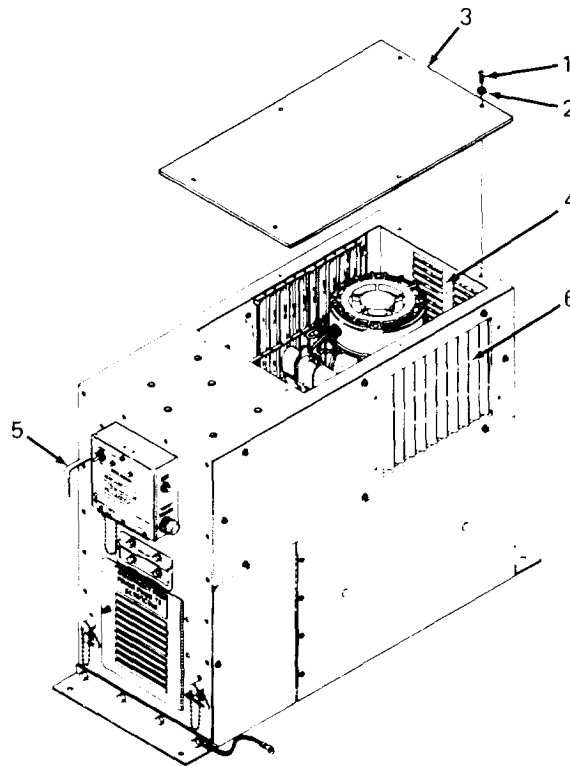

SERVICING:

WARNING

Dry cleaning solvent P-D-680 (safety or Stoddard's Solvent) is potentially dangerous. Avoid repeated and prolonged breathing of vapors and skin contact with the liquid. Do not use near open flame, arcing equipment, or other ignition sources. Always wear eye protection and protective clothing. Flash point of P-D-680 is 100° to 138° F (38° to 59° C).

Death or serious injury could occur if compressed air is directed against the skin. Do not use compressed air for cleaning or drying unless the pressure is/has been reduced to 30 psi (207 kPa) or less. When working with compressed air always use chip guards, eye protection, and other personal protective equipment.

1. Remove grease, oil, and fuel deposits by wiping with rags dampened with P-D-680 dry cleaning solvent. Remove excess dry cleaning solvent and dry with compressed air.
2. Lubricate louver pivots with antiseize compound.

ADJUST/INSPECT/SERVICE/REMOVE/INSTALL SIDE PANELS AND LOUVER LINKAGE (CONT)

REMOVAL:

WARNING

Death or serious injury could occur if precautions are not taken when maintaining this equipment. Position HEATER-OFF-FAN switch to OFF, remove power cable plug from POWER RECEPTACLE, and ground capacitors C1 and C2 at end cover of combustion blower. Always have another person standing by who is trained in electric shock first aid.

Remove electrical charge from ventilating air motor capacitor C3 by shorting out contacts using tool having insulated handle.

Allow sufficient time for heater to cool to room temperature before gaining access to heater compartments.

1. Remove six screws (1) and lock washers (2). Lift off bottom cover (3).
2. Reach through heater opening (4) and pull ends of louver linkages (5) out of holes in louver control bars (6).

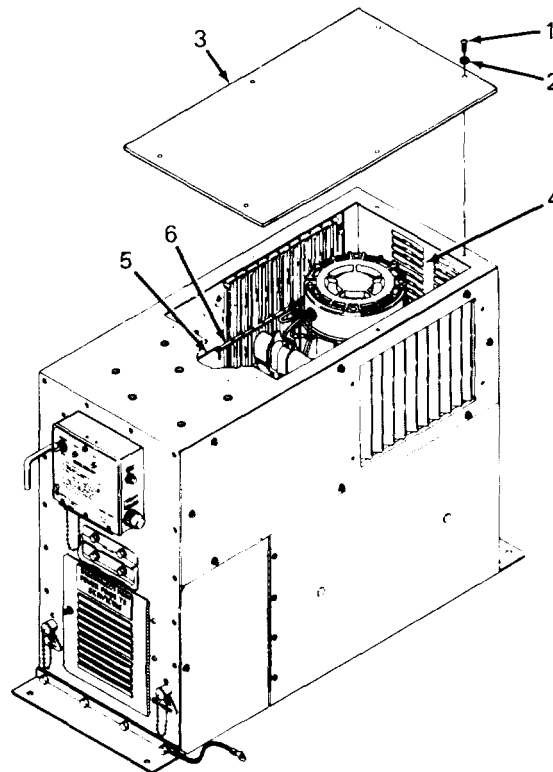

ADJUST/INSPECT/SERVICE/REMOVE/INSTALL SIDE PANELS AND LOUVER LINKAGE (CONT)

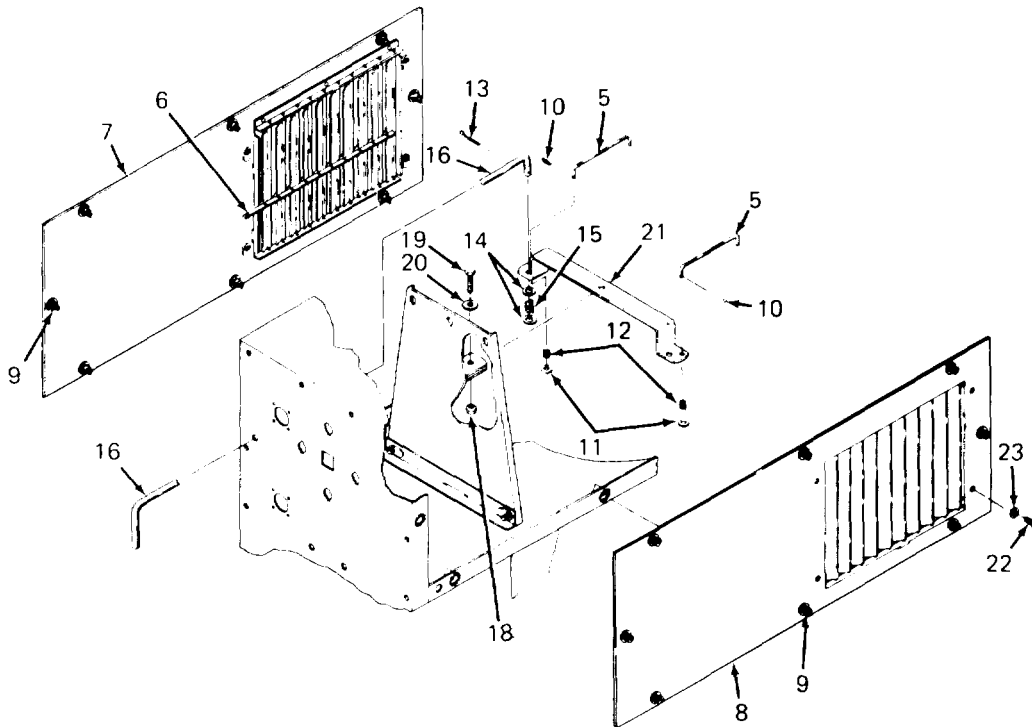

3. Remove right-hand and left-hand louver panels (7 and 8) by unlocking eight studs (9) at each panel,
4. Remove cotter pins (10), washers (11), and springs (12). Lift off louver linkages (5).
5. Remove cotter pin (13), washers (14), and spring (15). Lift off end of louver handle (16) and pull handle out through wall of heater case.
6. Unscrew nut (18) and remove screw (19) and washer (20). Lift off pivot bar (21).
7. Four screws (22) and lock washers (23) are installed in each louver panel at time of shipment. They secure side covers when side covers are used. If side covers are not used, do not remove screws (22) and lock washers (23).

INSTALLATION:



Do not overtighten nut (18) when installing pivot bar (21). Tighten only enough to allow free movement of the pivot bar.

1. Install pivot bar (21) using screw (19), washer (20), and nut (18). Place washer under head of screw.

**ADJUST/INSPECT/SERVICE/REMOVE/INSTALL SIDE PANELS AND
LOUVER LINKAGE (CONT)**

2. Install louver handle (16) through wall of heater case. Place end of louver handle through hole in pivot bar (21), place spring (15) and washers (14) over end of louver handle, and secure with cotter pin (13).
3. Place ends of louver linkages (5) through holes in pivot bar (21), place springs (12) and washers (11) over ends of louver linkages, and secure with cotter pins (10).
4. Install right-hand and left-hand louver panels (7 and 8) by locking eight studs (9) at each panel.
5. Reach through heater opening (4) and connect louver linkages (5) to louver control bars (6).
6. Install bottom cover (3) using six screws (1) and lock washers (2).

ADJUST/INSPECT/SERVICE/REMOVE/INSTALL DOORS AND BOTTOM COVER

TOOLS: Tool kit, service, refrigeration unit
 NSN 5180-00-596-1474

MATERIALS/PARTS: Antiseize compound (Item 1, Appendix E)
 Dry cleaning solvent (Item 13, Appendix E)

GENERAL SAFETY INSTRUCTIONS:

Power off.
 Heater cool.

ADJUSTMENT:

WARNING

Death or serious injury could occur if precautions are not taken when maintaining this equipment. Position HEATER-OFF-FAN switch to OFF, remove power cable plug from POWER RECEPTACLE, and ground capacitors C1 and C2 prior to gaining access to heater compartments. Terminals of capacitors are accessible at end cover of combustion blower. Always disconnect power cable before making continuity tests or before repairing heater. Always have another person standing by who is trained in electric shock first aid.

Allow sufficient time for heater to cool to room temperature before gaining access to heater compartments.

1. Right and left doors (1 and 2) and front access door (3) are adjusted by the same procedure as follows:
 - a. Loosen four screws (4) at right and left doors (1 and 2) or three screws (5) at front access door (3). Do not remove screws.
 - b. Adjust door vertically until studs (6 and 7) are aligned with their receptacles. Lock studs by rotating clockwise.
 - c. Tighten top and bottom screws (4 or 5) to slight tension. Door must be movable when tapped.
 - d. Tap door until top and bottom edges are perfectly horizontal. Tighten all screws (4 or 5) securely
2. There is no adjustment of the bottom cover.

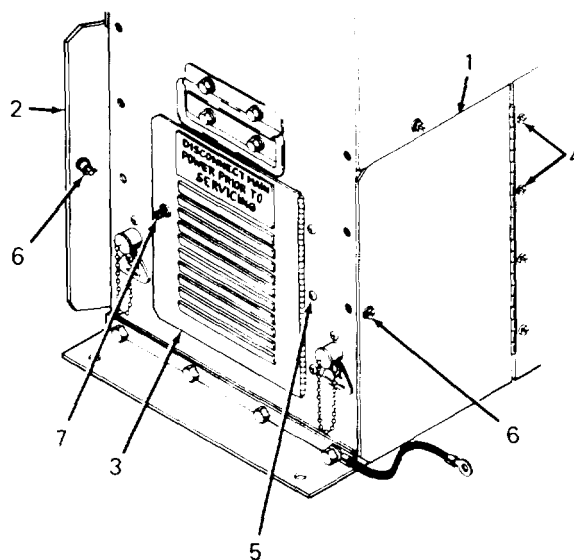

**ADJUST/INSPECT/SERVICE/REMOVE/INSTALL DOORS AND
BOTTOM COVER (CONT)****INSPECTION:**

1. Check doors and bottom cover for surface corrosion and scratches. If painting is required, forward heater to intermediate maintenance.
2. Check for dented or distorted doors and bottom cover. Doors that will not close properly and bottom cover which cannot be made to lie flat must be replaced.
3. Check studs for broken springs, bent pins, and looseness. Check for damaged and missing stud receptacles. Replace as needed. To replace stud, remove solid washer. Install new stud and press on new washer.
4. Check door hinges for broken tack welds. If welds are broken, replace door.

SERVICING:**WARNING**

Dry cleaning solvent P-D-680 (safety or Stoddard's Solvent) is potentially dangerous. Avoid repeated and prolonged breathing of vapors and skin contact with the liquid. Do not use near open flame, arcing equipment, or other ignition sources. Always wear eye protection and protective clothing. Flash point of P-D-680 is 100° to 138° F (38° to 59°C).

Death or serious injury could occur if compressed air is directed against the skin. Do not use compressed air for cleaning or drying unless the pressure is/has been reduced to 30 psi (207 kPa) or less. When working with compressed air always use chip guards, eye protection, and other personal protective equipment.

1. Remove grease, oil, and fuel deposits by wiping with rags dampened with P-D-680 dry cleaning solvent. Remove excess dry cleaning solvent and dry with compressed air.
2. Lubricate door hinges with antiseize compound.

ADJUST/INSPECT/SERVICE/REMOVE/INSTALL
 BOTTOM COVER (CONT)

DOORS

AND

REMOVAL:

WARNING

Death or serious injury could occur if precautions are not taken when maintaining this equipment. Position HEATER-OFF-FAN switch to OFF, remove power cable plug from POWER RECEPTACLE, and ground capacitors C1 and C2 at end cover of combustion blower. Always have another person standing by who is trained in electric shock first aid.

Remove electrical charge from ventilating air motor capacitor C3 by shorting out contacts using tool having insulated handle.

Allow sufficient time for heater to cool to room temperature before gaining access to heater compartments.

NOTE

Open right and left doors and front access door to allow access to hardware inside heater case during removal.

1. Remove six screws (1) and lock washers (2) and lift off bottom cover (3).
2. Remove four screws (4), lock washers (5), and nuts (6). Lift off left door (7). Use same procedure for removing right door.
3. Remove three screws (8), lock washers (9), and nuts (10). Lift off front access door (11).

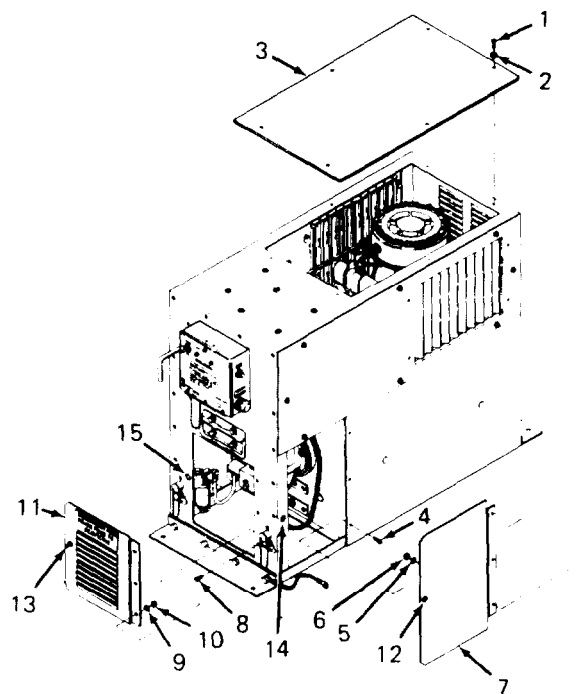

**ADJUST/INSPECT/SERVICE/REMOVE/INSTALL DOORS AND
BOTTOM COVER (CONT)****INSTALLATION:**

1. Loosely install front access door (11) using three screws (8), lock washers (9), and nuts (10). Do not tighten screws.
2. Loosely install left door (7) using four screws (4), lock washers (5), and nuts (6). Do not tighten screws. Use same procedure for installing right door.
3. Adjust each door vertically until studs (12 and 13) are aligned with receptacles (14 and 15). Lock studs by rotating clockwise,
4. Tighten top and bottom screws (4 or 8) to slight tension. Door must be movable when tapped.
5. Tap door until top and bottom edges are horizontal. Tighten all screws (4 or 8).
6. Install bottom cover (3) using six screws (1) and lock washers (2).

INSPECT/REMOVE/INSTALL DATA PLATES

TOOLS: Tool kit, service, refrigeration unit
NSN 5180-00-596-1474

Solder gun kit
NSN 3439-00-930-1638

MATERIALS/PARTS: Solder (Item 12, Appendix E)
Butt connector (4)
Tubular brass rivet, brazier head (8)
Pop rivet (4)

GENERAL SAFETY INSTRUCTIONS:

Power off.
Heater cool.

INSPECTION:

WARNING

Death or serious injury could occur if precautions are not taken when maintaining this equipment. Position HEATER-OFF-FAN switch to OFF, remove power cable plug from POWER RECEPTACLE, and ground capacitors C1 and C2 prior to gaining access to heater compartments. Terminals of capacitors are accessible at end cover of combustion blower. Always disconnect power cable before making continuity tests or before repairing heater. Always have another person standing by who is trained in electric shock first aid.

Allow sufficient time for heater to cool to room temperature before gaining access to heater compartments.

1. Check identification plate (1), name plate (2), wiring diagram plate (3), and sequence of operation plate (4) for legibility. If data plate (2, 3, or 4) is scratched, worn, or otherwise damaged causing all or part of it to be unreadable, replace plate. Identification plate (1) is not replaceable,
2. Check identification plate (1), wiring diagram plate (3), and sequence of operation plate (4) for loose or broken rivets. Tighten or replace rivets as needed,

INSPECT/REMOVE/INSTALL DATA PLATES (CONT)

3. Nameplate (2) is printed on heavy-gauge aluminum. It is the control box cover. Check for loose rivets at hinge. Check for distortion causing difficult closing or locking. Replace defective cover.

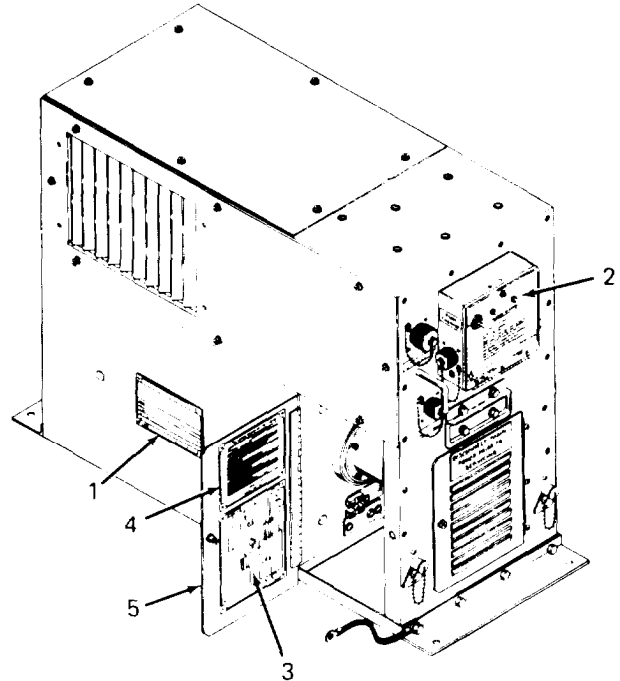
**REMOVAL:****NOTE**

Identification plate (1) is normally never removed. If removed, same identification plate must be installed.

1. Remove identification plate (1) by drilling out four blind rivets from outside heater case. Retain identification plate for reinstallation.
2. Remove wiring diagram plate (3) and sequence of operation plate (4) by drilling out eight tubular brass rivets from inside right door (5).

WARNING

Death or serious injury could occur if precautions are not taken when maintaining this equipment. Position HEATER-OFF-FAN switch to OFF, remove power cable plug from POWER RECEPTACLE, and ground capacitors C1 and C2 at end cover of combustion blower. Always have another person standing by who is trained in electric shock first aid.

3. Removal of the name plate consists of removing the control box cover (1). Proceed as follows:
 - a. Disconnect violet wire (5) and yellow wire (7) from leads of FAULT light (2). Disconnect white wire (12) and orange wire (13) from leads of HEAT light (3). Discard butt connectors (4). Wire numbers are same as those appearing in table 3-5.
 - b. Grasp barrel fasteners (6) with pliers and forcibly remove. Discard fasteners.

INSPECT/REMOVE/INSTALL DATA PLATES (CONT)

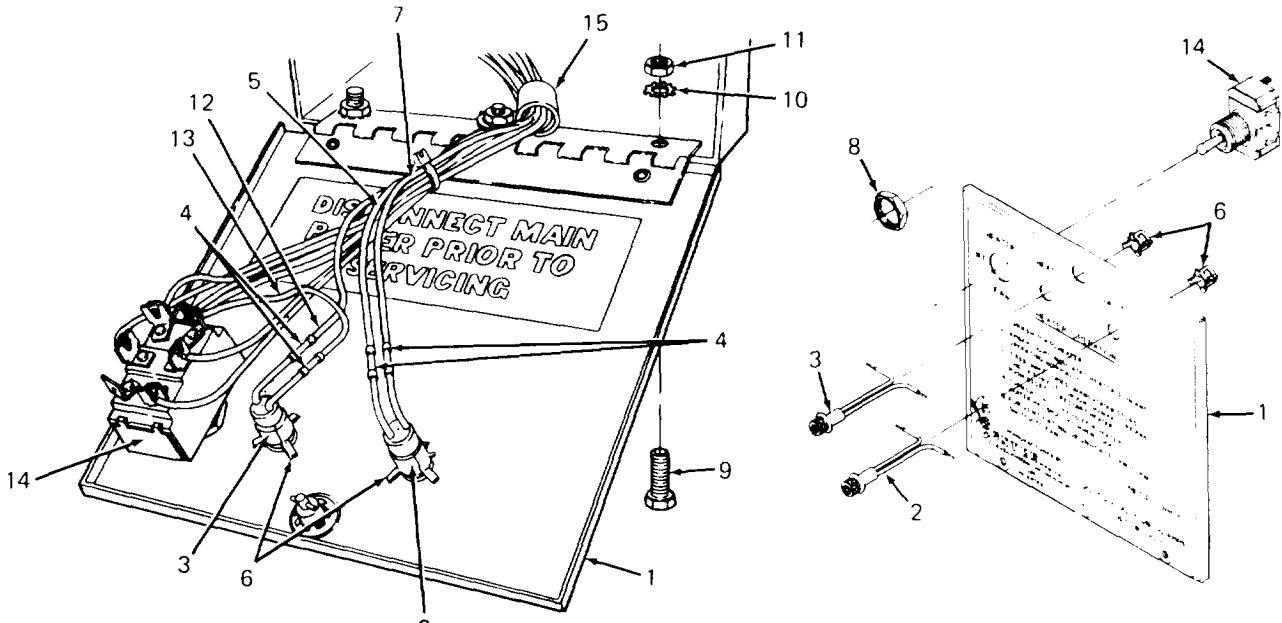

- c. Pull FAULT and HEAT lights (2 and 3) out of mounting holes from front of control box cover (1).
- d. Remove hex nut (8) at front of control box cover (1) and pull HEATER-OFF-FAN switch (14) out of mounting hole from back of cover.
- e. Remove three screws (9), lock washers (10), and nuts (11). One combination screw/lock washer/nut retains harness clamp (15). Remove harness clamp and lift off control box cover (1).

INSTALLATION:

1. Install original identification plate (1) using four blind rivets (2).
2. Install wiring diagram plate (3) using four tubular brass rivets (4). Install sequence of operation plate using four rivets (4). Install all rivets (4) with heads on outside of right door (6).

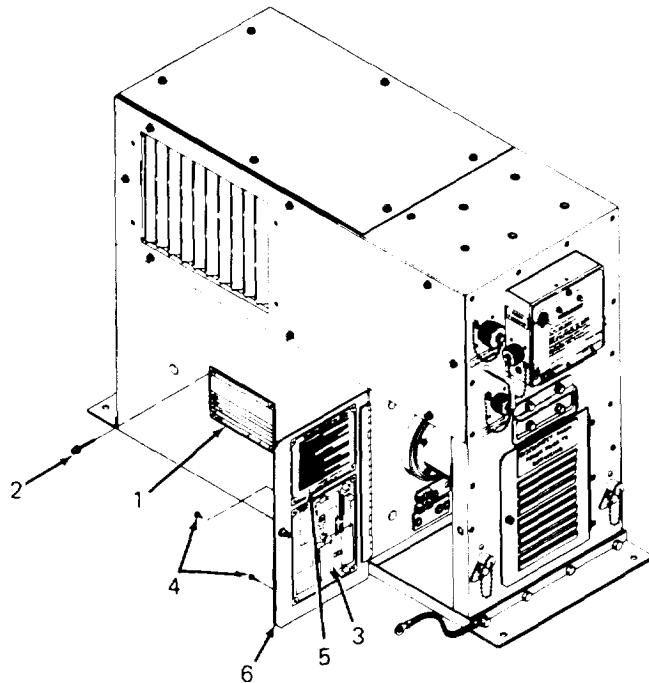

INSPECT/REMOVE/INSTALL DATA PLATES (CONT)

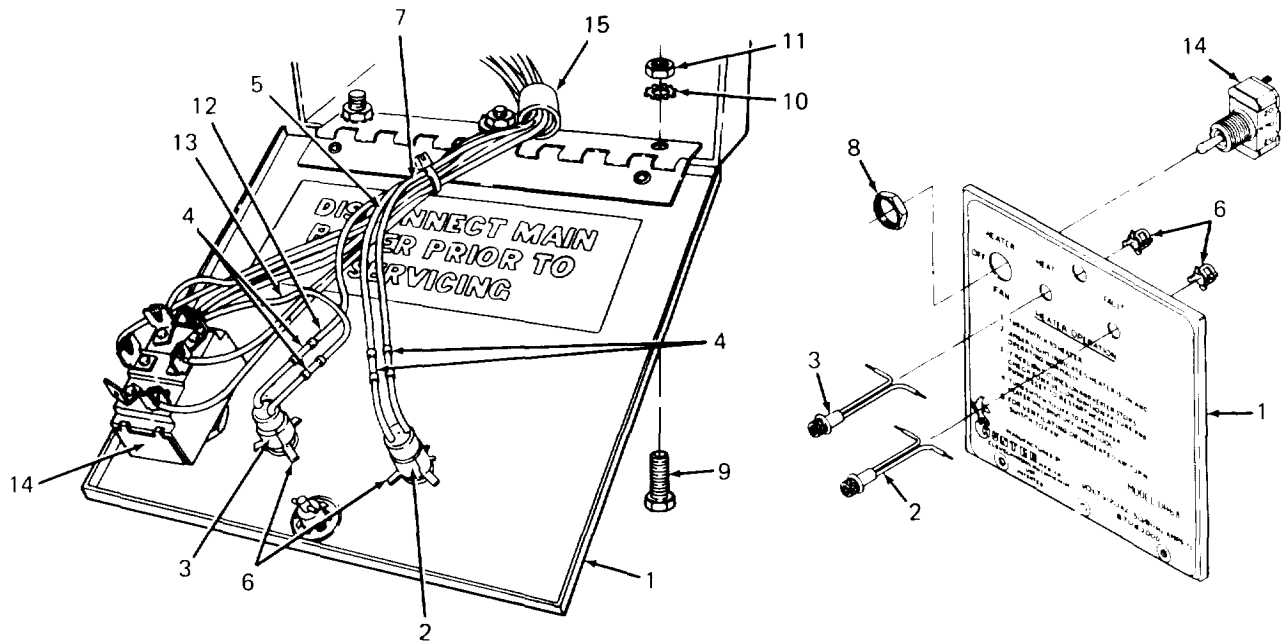

3. Install name plate by installing control box cover (1) as follows:

- a. Thread wires of FAULT and HEAT lights (2 and 3) through mounting holes from front of control box cover (1). Seat white light in mounting hole marked HEAT and red light in hole marked FAULT.
- b. Secure lights with barrel fasteners (6).
- c. Install HEATER-OFF-FAN switch (14) through mounting hole from back of cover (1) and secure at front of cover with hex nut (8).
- d. Install harness clamp (15) around harness wires. Install cover (1) on control box using three screws (9), lock washers (10), and nuts (11). Use one combination screw/lock washer/nut to secure harness clamp as illustrated.
- e. Connect violet wire (5) and yellow wire (7) to leads of FAULT light (2). Connect white wire (12) and orange wire (13) to leads of HEAT light (3). use new butt connectors (4).
- f. If in doubt as to location of any wire, find wire number in table 3-5 and check From/To columns.

INSPECT/REMOVE/INSTALL LABELS

MATERIALS/PARTS: Dry cleaning solvent (Item 13, Appendix E)

INSPECTION:

WARNING

Death or serious injury could occur if precautions are not taken when maintaining this equipment. Position HEATER-OFF-FAN switch to OFF, remove power cable plug from POWER RECEPTACLE, and ground capacitors C1 and C2 prior to gaining access to heater compartments. Terminals of capacitors are accessible at end cover of combustion blower. Always disconnect power cable before making continuity tests or before repairing heater. Always have another person standing by who is trained in electric shock first aid.

Allow sufficient time for heater to cool to room temperature before gaining access to heater compartments.

1. Refer to paragraph 2-8 and check all labels for legibility and security. If label is unreadable, replace.
2. If label has partially peeled, press it back in place. Replace labels which will not stick to surface.

REMOVAL/INSTALLATION:

1. Peel off defective label.

WARNING

Dry cleaning solvent P-D-680 (safety or Stoddard's Solvent) is potentially dangerous. Avoid repeated and prolonged breathing of vapors and skin contact with the liquid. Do not use near open flame, arcing equipment, or other ignition sources. Always wear eye protection and protective clothing. Flash point of P-D-680 is 100° to 138° F (38° to 59° C).

2. Use rag dampened with P-D-680 dry cleaning solvent to clean off old adhesive, dirt, and grease or oil. Allow surface to air dry.
3. Carefully apply appropriate pressure sensitive label.

FUEL SYSTEM PROCEDURES INDEX

PROCEDURE	PAGE
Inspect/Repair/Remove/Install Fuel Lines and Fittings	3-85
Service/Remove/install Fuel Filter	3-89
Inspect/Service/Adjust/Remove/Install Carburetor	3-92
Inspect/Test/Remove/Install Solenoid	3-97

INSPECT/REPAIR/REMOVE/INSTALL FUEL LINES AND FITTINGS

TOOLS: Tool kit, service, refrigeration unit
 NSN 5180-00-596-1474

GENERAL SAFETY INSTRUCTIONS:

- Power off.
- Heater cool.
- Well-ventilated area.

INSPECTION:



Death or serious injury could occur if precautions are not taken when maintaining this equipment. Position HEATER-OFF-FAN switch to OFF, remove power cable plug from POWER RECEPTACLE, and ground capacitors C1 and C2 prior to gaining access to heater compartments. Terminals of capacitors are accessible at end cover of combustion blower. Always disconnect power cable before making continuity tests or before repairing heater. Always have another person standing by who is trained in electric shock first aid.

Allow sufficient time for heater to cool to room temperature before gaining access to heater compartments.

Death or serious injury could occur if fuel is not handled carefully. Use in a well-ventilated area away from open flame, arcing equipment, ignition sources, heaters, or excessive heat. Engines must be turned off and cool before refueling. Use proper refueling procedures and equipment to avoid spillage. Do not run engines near open fuel containers. Do not use fuel as a cleaning solvent. **DO NOT SMOKE.**

1. Check nylon tubing fuel lines (1 and 2) for kinks, cuts, or breaks. Check for leaks at male elbows (3) and tighten fittings if needed.

INSPECT/REPAIR/REMOVE/ INSTALL FUEL LINES AND FITTINGS (CONT)

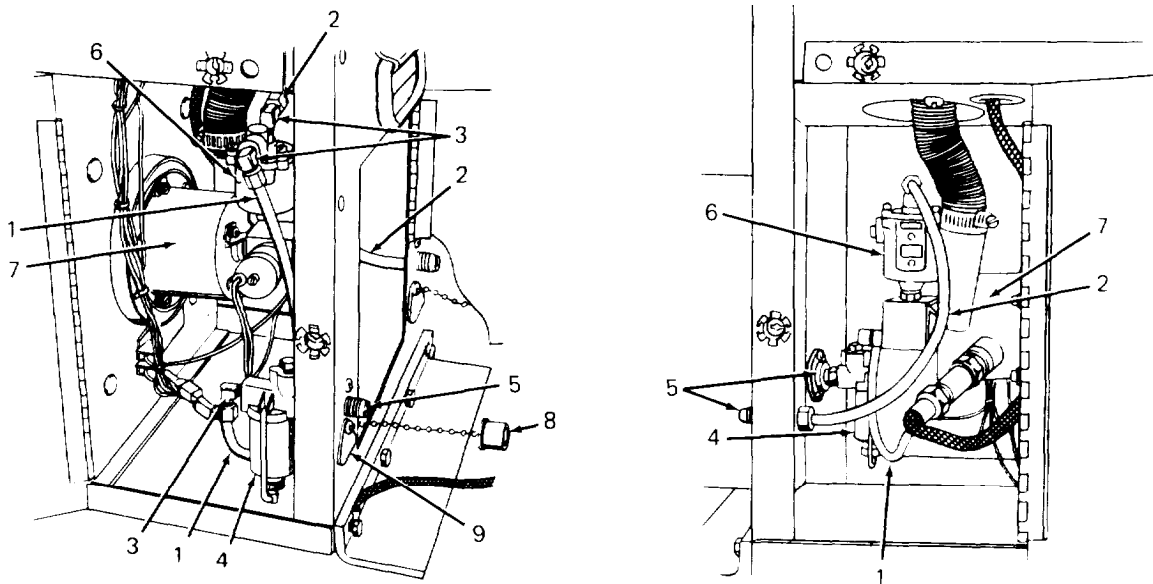

2. Check for fuel leaks in fuel filter (4). Check fuel filter bowl for security.
3. Check bulkhead fittings (5) for leaks and security.
4. Check carburetor (6) for leaks and secure mounting to burner head (7)
5. Check for presence of cap Plum (8) and fuel tags (9). Note position of fuel tags when heater is viewed from front and mounted as illustrated. FUEL INLET tag should be on-your left and FUEL OVERFLOW tag should be on your right. Replace cap plugs (8) if beaded connector is broken or cap missing. Replace missing fuel tags and reposition them under correct bulkhead fitting if needed.

REPAIR:

Repair consists of tightening loose connections, securing loosely mounted parts, and replacing damaged or defective parts.

INSPECT/REPAIR/REMOVE/INSTALL FUEL LINES AND FITTINGS (CONT)

REMOVAL:

WARNING

Death or serious injury could occur if fuel is not handled carefully. Use in a well-ventilated area away from open flame, arcing equipment, ignition sources, heaters, or excessive heat. Engines must be turned off and cool before refueling. Use proper refueling procedures and equipment to avoid spillage. Do not run engines near open fuel containers. Do not use fuel as a cleaning solvent. **DO NOT SMOKE.**

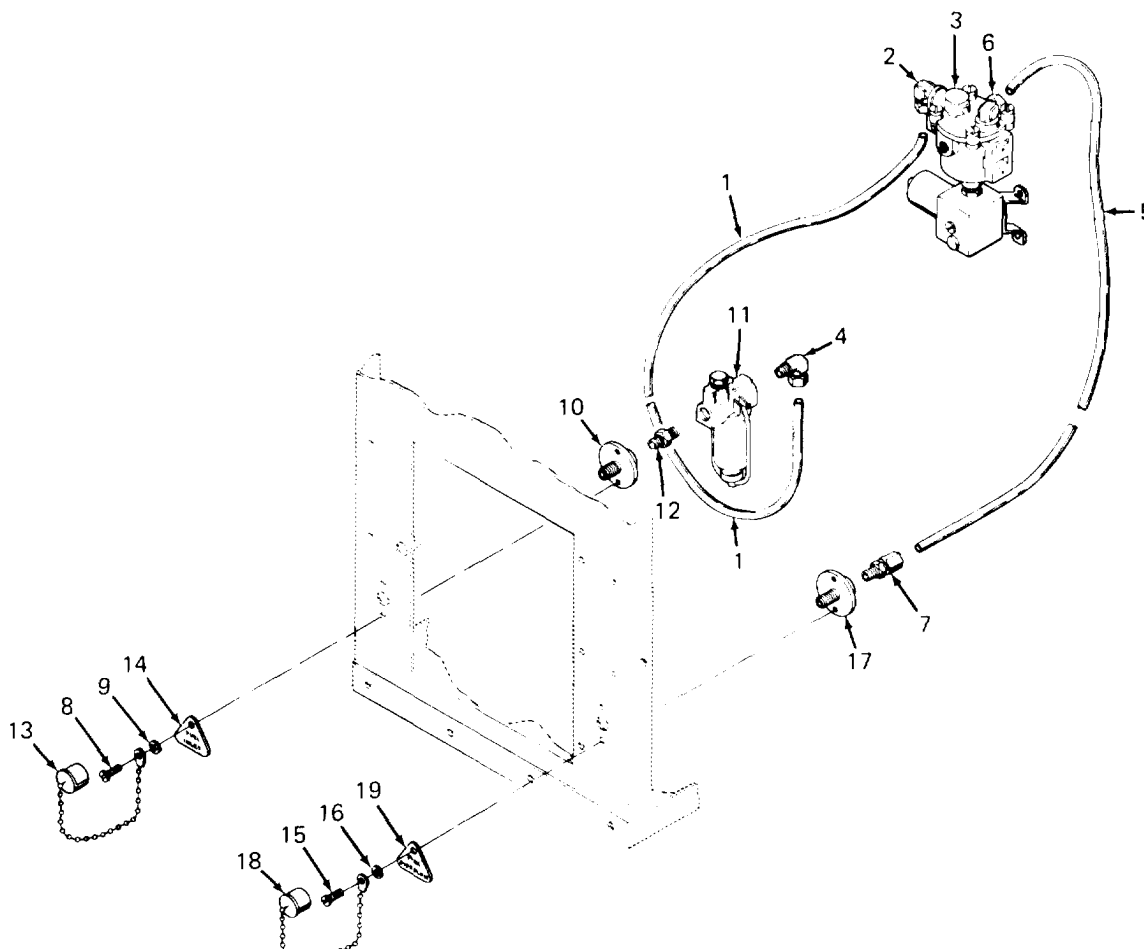

1. Close shutoff valve at fuel container.
2. Remove fuel line (1) by loosening nuts at male elbow (2) of carburetor (3) and male elbow (4) of fuel filter (11).

INSPECT/REPAIR/REMOVE/INSTALL FUEL LINES AND FITTINGS (CONT)

3. Remove fuel line (5) by loosening nuts at male elbow (6) of carburetor (3) and male connector (7).
4. Remove two screws (8) and lock washers (9) and pull FUEL INLET bulkhead fitting (10) out of mounting hole from inside heater case. Fuel filter (11) is attached.
5. Bottom screw (8) also retains cap plug (13) and FUEL INLET tag (14). Carefully retain these parts for reassembly.
6. Remove two screws (15) and lock washers (16) and pull FUEL OVERFLOW bulkhead fitting (17) out of mounting hole from inside heater case.
7. Bottom screw (15) also retains cap plug (18) and FUEL OVERFLOW tag (19). Carefully retain these parts for reassembly.
8. Disassemble FUEL INLET bulkhead fitting (10), fuel filter (11), nipple (12), and male elbow (4).
9. Disassemble FUEL OVERFLOW bulkhead fitting (17) and male connector (7).
10. With fuel lines and fittings disassembled, inspect fittings for stripped or crossed threads and other damage. Replace damaged or defective fittings.

INSTALLATION:

1. Assemble FUEL OVERFLOW bulkhead fitting (17) and male connector (7).
2. Assemble FUEL INLET bulkhead fitting (10), fuel filter (11), nipple (12), and male elbow (4).
3. Install FUEL OVERFLOW bulkhead fitting (17) in mounting hole from inside heater case and secure with two screws (15) and lock washers (16). Bottom screw (15) also secures cap plug (18) and FUEL OVERFLOW tag (19). Place tag between lock washer (16) and heater case. Fasten cap plug (18) between lock washer (16) and screw (15).
4. Install FUEL INLET bulkhead fitting (10) in mounting hole from inside heater case and secure with two screws (8) and lock washers (9). Bottom screw (8) also secures cap plug (13) and FUEL INLET tag (14). Place tag between lock washer (9) and heater case. Fasten cap plug (13) between lock washer (9) and screw (8).
5. Install fuel line (5) in male elbow (6) of carburetor (3) and male connector (7). Secure by tightening nuts of fittings.
6. Install fuel line (1) in male elbow (2) of carburetor (3) and male elbow (4), Secure by tightening nuts of fittings.
7. Open shutoff valve at fuel container if heater is to be used.

SERVICE/REMOVE/INSTALL FUEL FILTER

TOOLS: Tool kit, service, refrigeration unit
NSN 5180-00-596-1474

MATERIALS/PARTS: Dry cleaning solvent (Item 13, Appendix E)

GENERAL SAFETY INSTRUCTIONS:

Power off.
Heater cool.
Well-ventilated area.

SERVICE:**WARNING**

Death or serious injury could occur if precautions are not taken when maintaining this equipment. Position HEATER-OFF-FAN switch to OFF, remove power cable plug from POWER RECEPTACLE, and ground capacitors C1 and C2 at end cover of combustion blower. Always have another person standing by who is trained in electric shock first aid.

Allow sufficient time for heater to cool to room temperature before gaining access to heater compartments.

Death or serious injury could occur if fuel is not handled carefully. Use in a well-ventilated area away from open flame, arcing equipment, ignition sources, heaters, or excessive heat. Engines must be turned off and cool before refueling. Use proper refueling procedures and equipment to avoid spillage. Do not run engines near open fuel containers. Do not use fuel as a cleaning solvent. **DO NOT SMOKE.**

1. Close shutoff valve at fuel container.
2. Loosen thumbscrew (1) on wire bail (2). Swing bail out from under filter bowl (3)

SERVICE/REMOVE/INSTALL FUEL FILTER (CONT)

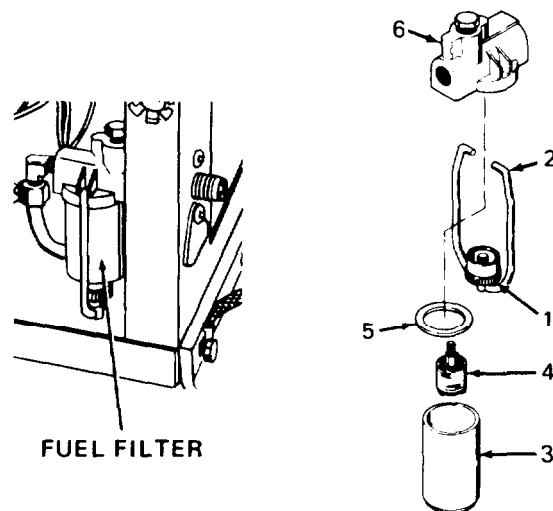

3. Remove bowl (3), filter element (4), and gasket (5) from filter head (6).

WARNING

Dry cleaning solvent P-D-680 (safety or Stoddard's Solvent) is potentially dangerous. Avoid repeated and prolonged breathing of vapors and skin contact with the liquid. Do not use near open flame, arcing equipment, or other ignition sources. Always wear eye protection and protective clothing. Flash point of P-D-680 is 100° to 138° F (38° to 59°C).

Death or serious injury could occur if compressed air is directed against the skin. Do not use compressed air for cleaning or drying unless the pressure is/has been reduced to 30 psi (207 kPa) or less. When working with compressed air always use chip guards, eye protection, and other personal protective equipment.

4. Clean filter element (4), gasket (5), and bowl (3) in P-D-680 dry cleaning solvent. Shake off excess and dry parts with compressed air. If filter element cannot be cleaned, replace with new element. If gasket is cracked or damaged, replace it.
5. Install filter element (4) and gasket (5) in filter head (6). Place filter bowl (3) over filter element and against gasket.
6. Swing wire bail (2) under bowl and tighten thumbscrew (1) against bottom of bowl until leakproof seal is achieved.

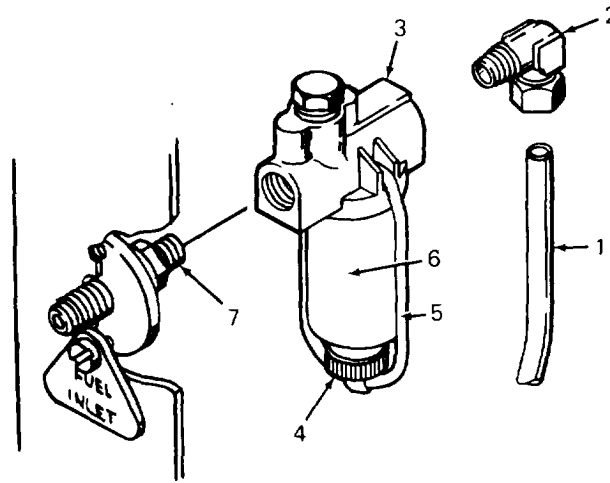
SERVICE/REMOVE/INSTALL FUEL FILTER (CONT)**REMOVAL:**

1. Disconnect fuel line (1) by loosening nut of male elbow (2).
2. Remove male elbow (2) from fuel filter (3).
3. Loosen thumbscrew (4), swing wire bail (5) out from under filter bowl (6), and remove bowl.
4. Remove fuel filter (3) from nipple (7).

INSTALLATION:

1. Install fuel filter (3) on nipple (4).
2. Assemble filter bowl (6) to fuel filter (3), swing bail (5) under filter bowl, and tighten thumbscrew (4).
3. Install male elbow (2) in fuel filter (3).
4. Install fuel line (1) in male elbow (2) and secure by tightening nut of elbow.
5. Open shutoff valve at fuel container if heater is to be used.

INSPECT/SERVICE/ADJUST/REMOVE/INSTALL CARBURETOR

TOOLS: Tool kit, service, refrigeration unit
NSN 5180-00-596-1474

MATERIALS/PARTS: Dry cleaning solvent (Item 13, Appendix E)

INSPECTION:

1. Check carburetor for security. Tighten screws (1) if needed.
2. Check nipple (2) and male elbows (3) for leaks,
3. Check solenoid (4) for security and leakage.
4. Check installation of carburetor heater (5) and electrical connections (6).

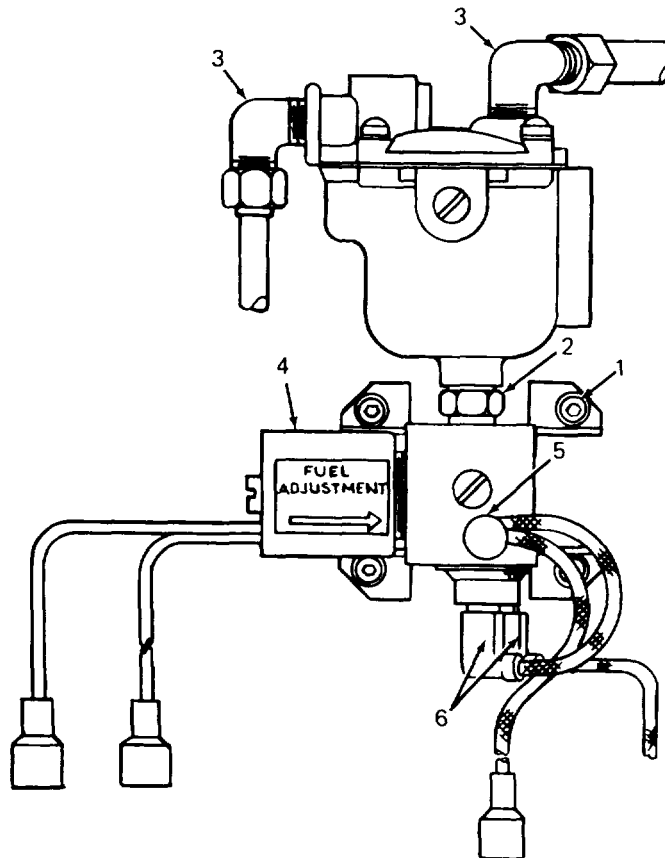

INSPECT/SERVICE/ADJUST/REMOVE/INSTALL CARBURETOR CONT**SERVICE:**

1. Disconnect fuel tube (1) by loosening nut of male elbow (2).
2. Remove elbow (2) and lift float bowl inlet screen (3) out of inlet (4) of float bowl (5).

WARNING

Death or serious injury could occur if fuel is not handled carefully. Use in a well-ventilated area away from open flame, arcing equipment, ignition sources, heaters, or excessive heat. Engines must be turned off and cool before refueling. Use proper refueling procedures and equipment to avoid spillage. Do not run engines near open fuel containers. Do not use fuel as a cleaning solvent. **DO NOT SMOKE.**

Dry cleaning solvent P-D-680 (safety or Stoddard's Solvent) is potentially dangerous. Avoid repeated and prolonged breathing of vapors and skin contact with the liquid. Do not use near open flame, arcing equipment, or other ignition sources. Always wear eye protection and protective clothing. Flash point of P-D-680 is 100° to 138° F (38° to 59° C).

Death or serious injury could occur if compressed air is directed against the skin. Do not use compressed air for cleaning or drying unless the pressure is/has been reduced to 30 psi (207 kPa) or less. When working with compressed air always use chip guards, eye protection, and other personal protective equipment.

3. Clean screen (3) by dissolving deposits in P-D-680 dry cleaning solvent.
4. Shake off excess dry cleaning solvent and dry with compressed air.
5. Check screen (3) for remaining deposits, punctures, or distortion. If screen cannot be completely cleared of deposits or is damaged, replace.
6. Install float bowl inlet screen (3) in inlet (4) of float bowl (5).
7. Install fuel tube (1) in male elbow (2) and tighten elbow nut.

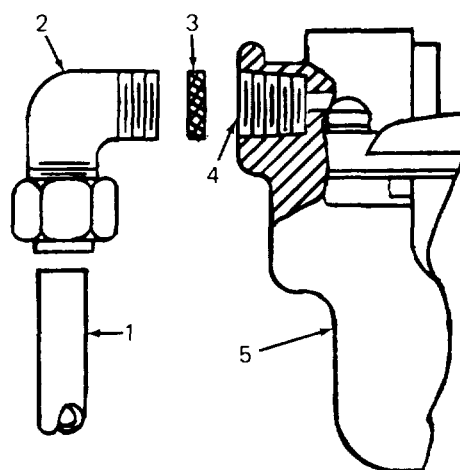

ADJUSTMENT:

WARNING

Do not operate heater in enclosure unless exhaust gases are piped outside. Exhaust gases contain carbon monoxide, a colorless, odorless, deadly poisonous gas. Failure to provide proper elimination of the exhaust can cause severe illness or death.

1. Place HEATER-OFF-FAN switch in HEATER position. Allow heater to heat up to normal operating temperature.
2. Open front access door (1) and locate fuel needle (2).

CAUTION

When turning needle valve all the way in, do not force. Use light pressure to avoid damage to valve.

3. Turn fuel needle (2) clockwise as far as possible.
4. Turn fuel needle (2) counterclockwise in 1/8-turn increments. Increase fuel flow until there is no odor of unburned fuel and no smoke in exhaust fumes.
5. In low ambient temperatures it may be necessary to increase fuel flow to achieve smooth burner operation.

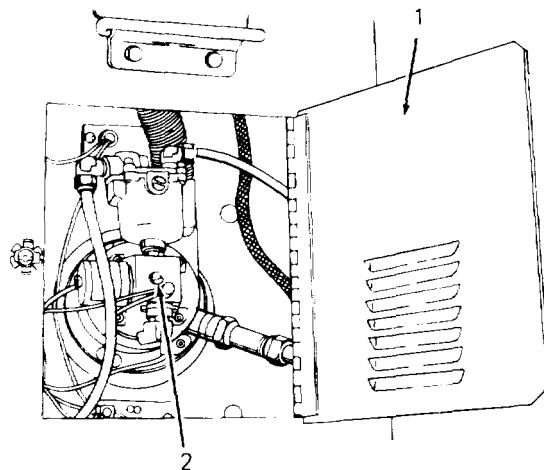

INSPECT/SERVICE/ADJUST/REMOVE/INSTALL CARBURETOR (CONT)

REMOVAL:

WARNING

Death or serious injury could occur if precautions are not taken when maintaining this equipment. Position HEATER-OFF-FAN switch to OFF, remove power cable plug from POWER RECEPTACLE, and ground capacitors C1 and C2 prior to gaining access to heater compartments. Terminals of capacitors are accessible at end cover of combustion blower. Always disconnect power cable before making continuity tests or before repairing heater. Always have another person standing by who is trained in electric shock first aid.

Allow sufficient time for heater to cool to room temperature before gaining access to heater compartments.

Death or serious injury could occur if fuel is not handled carefully. Use in a well-ventilated area away from open flame, arcing equipment, ignition sources, heaters, or excessive heat. Engines must be turned off and cool before refueling. Use proper refueling procedures and equipment to avoid spillage. Do not run engines near open fuel containers. Do not use fuel as a cleaning solvent. **DO NOT SMOKE.**

1. Close shutoff valve at fuel container.
2. Disconnect fuel lines (1 and 2) by loosening nuts of male elbows (3 and 4).
3. Tag orange wire (5) and disconnect from fuel preheat thermostat (6). Wire (5) is part of PC board assembly.
4. Tag wires and disconnect wire (7) from thermostat (6) and wire (8) from white wire of PC board assembly. Wires (7 and 8) are part of carburetor heater (9). Remove carburetor heater and retain for reassembly.
5. Tag and disconnect wires (10 and 11) from green and blue wires of PC board assembly.
6. Remove four screws (12) and lock washers (13) and lift off carburetor (14).

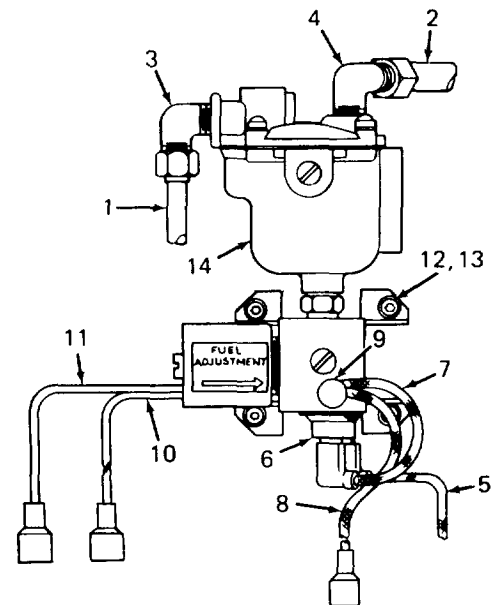

INSPECT/SERVICE/ADJUST/REMOVE/INSTALL CARBURETOR (CONT)

INSTALLATION:

1. Install carburetor on burner head using four screws (12) and lock washers (13).
2. Connect wires (10 and 11) to green and blue wires of PC board assembly in accordance with tags.
3. Install carburetor heater (9) in carburetor (14). Connect wire (8) to white wire of PC board assembly and wire (7) to fuel preheat thermostat (6).
4. Locate orange wire (5) and connect it to fuel preheat thermostat (6).
5. Install fuel lines (1 and 2) and secure by tightening nuts of male elbows (3 and 4).
6. Open shutoff valve at fuel container.

INSPECT/TEST/REMOVE/INSTALL SOLENOID

TOOLS: Tool kit, service, refrigeration unit
NSN 5180-00-596-1474

MATERIALS/PARTS: O-Ring

GENERAL SAFETY INSTRUCTIONS:

Power off.
Heater cool.

INSPECTION:**WARNING**

Death or serious injury could occur if precautions are not taken when maintaining this equipment. Position HEATER-OFF-FAN switch to OFF, remove power cable plug from POWER RECEPTACLE, and ground capacitors C1 and C2 prior to gaining access to heater compartments. Terminals of capacitors are accessible at end cover of combustion blower. Always disconnect power cable before making continuity tests or before repairing heater. Always have another person standing by who is trained in electric shock first aid.

Allow sufficient time for heater to cool to room temperature before gaining access to heater compartments.

1. Check for fuel leakage where solenoid (1) is screwed into carburetor body (2). Tighten solenoid with screwdriver to stop leakage.

INSPECT/TEST/REMOVE/INSTALL SOLENOID (CONT)

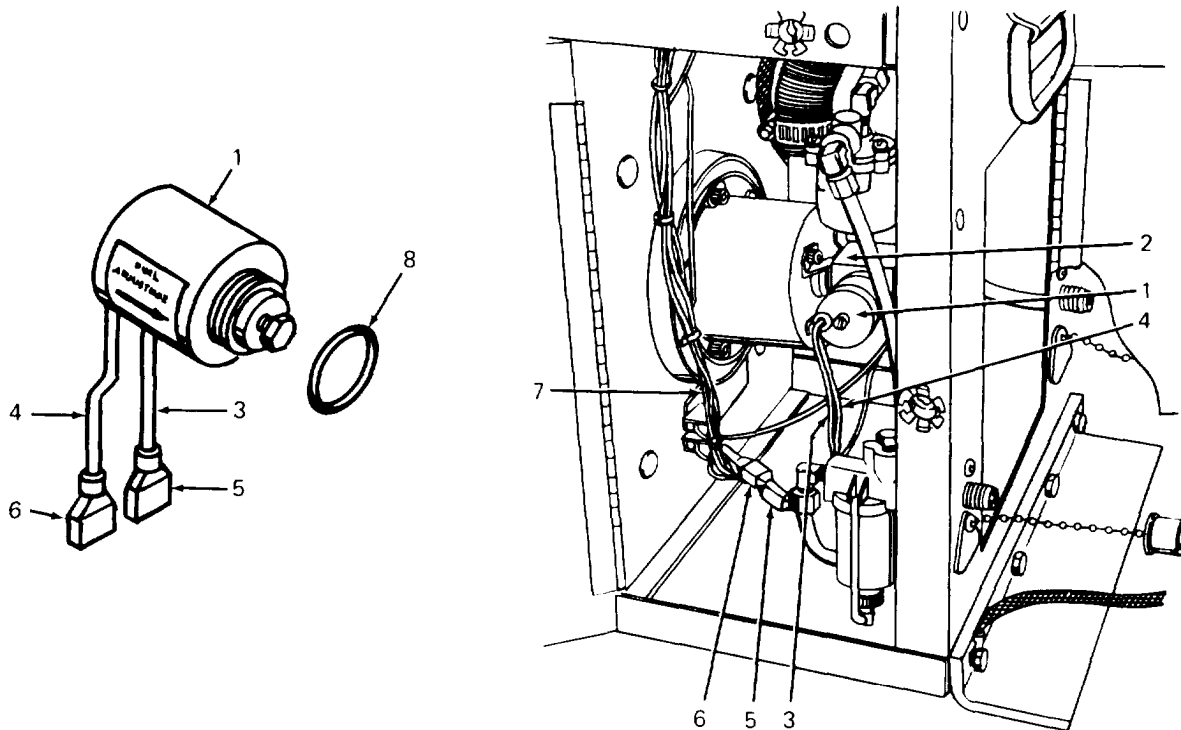

2. Check solenoid wires (3 and 4) for cuts or breaks in insulation and loose or damaged male coupler terminals (5 and 6). Replace defective terminals. If wire is damaged close to terminal end, small amount of wire can be removed. Wires must still be long enough to reach terminals of green and blue wires of PC board assembly wiring (7). Otherwise, replace solenoid (1).

TESTING:

1. Disconnect wires (3 and 4) from PC board assembly wiring (7). Tag all wires.
2. Connect wires (3 and 4) to a 24 V dc power source.
3. Alternately make and break the circuit by touching and removing one of wires (3 or 4) from the power source. If solenoid (1) is good, a clicking sound will be heard when the valve opens or closes. If no sound is heard, solenoid is defective. Replace with good solenoid.

INSPECT/TEST/REMOVE/INSTALL SOLENOID (CONT)**REMOVAL:****WARNING**

Death or serious injury could occur if fuel is not handled carefully. Use in a well-ventilated area away from open flame, arcing equipment, ignition sources, heaters, or excessive heat. Engines must be turned off and cool before refueling. Use proper refueling procedures and equipment to avoid spillage. Do not run engines near open fuel containers. Do not use fuel as a cleaning solvent. DO NOT SMOKE.

1. Close shutoff valve at fuel container,
2. Disconnect wires (3 and 4) from PC board assembly wiring (7). Tag all wires.
3. Use screwdriver to unscrew solenoid (1) from carburetor body (2).
4. Remove O-ring (8) and discard.

INSTALLATION:

1. Install new O-ring (8) in carburetor body (2).
2. Install solenoid (1) using screwdriver. Tighten securely.
3. Connect wires (3 and 4) to PC board assembly wiring (7) in accordance with tags.
4. Open shutoff valve at fuel container if heater is to be used.

ELECTRICAL PROCEDURES INDEX

PROCEDURE	PAGE
Inspect Combustion Blower	3-100
Inspect Ventilating Air Motor	3-102
Inspect/Test/Remove/Install Safety Thermostats and Flame Switch and Bracket Assembly	3-105

INSPECT COMBUSTION BLOWER

TOOLS: Tool kit, service, refrigeration unit
 NSN 5180-00-596-1474

INSPECTION:

WARNING

Death or serious injury could occur if precautions are not taken when maintaining this equipment. Position HEATER-OFF -FAN switch to OFF, remove power cable plug from POWER RECEPTACLE, and ground capacitors C1 and C2 prior to gaining access to heater compartments. Terminals of capacitors are accessible at end cover of combustion blower. Always have another parson standing by who is trained in electric shock first aid.

Allow sufficient time for heater to cool to room temperature before gaining access to heater compartments.

1. Remove six screws (1) and lock washers (2). Lift off bottom cover (3).
2. Reach through heater opening (4) and disconnect louver linkages from louvers.
3. Remove louver panels (5 and 6) by unlocking eight studs (7) at each panel.
4. Open side doors (8 and 9) and front access door (10).
5. Check mounting screws (11) for security.
6. Check support tube (12) for security. Be sure that screw (13) holds combustion blower (14) firmly against support tube (12).
7. Be sure hose clamps (15 and 16) are tight.
8. Check combustion blower air duct from all available angles for punctures, breaks, or distortion causing restricted air flow.

INSPECT COMBUSTION BLOWER (CONT)

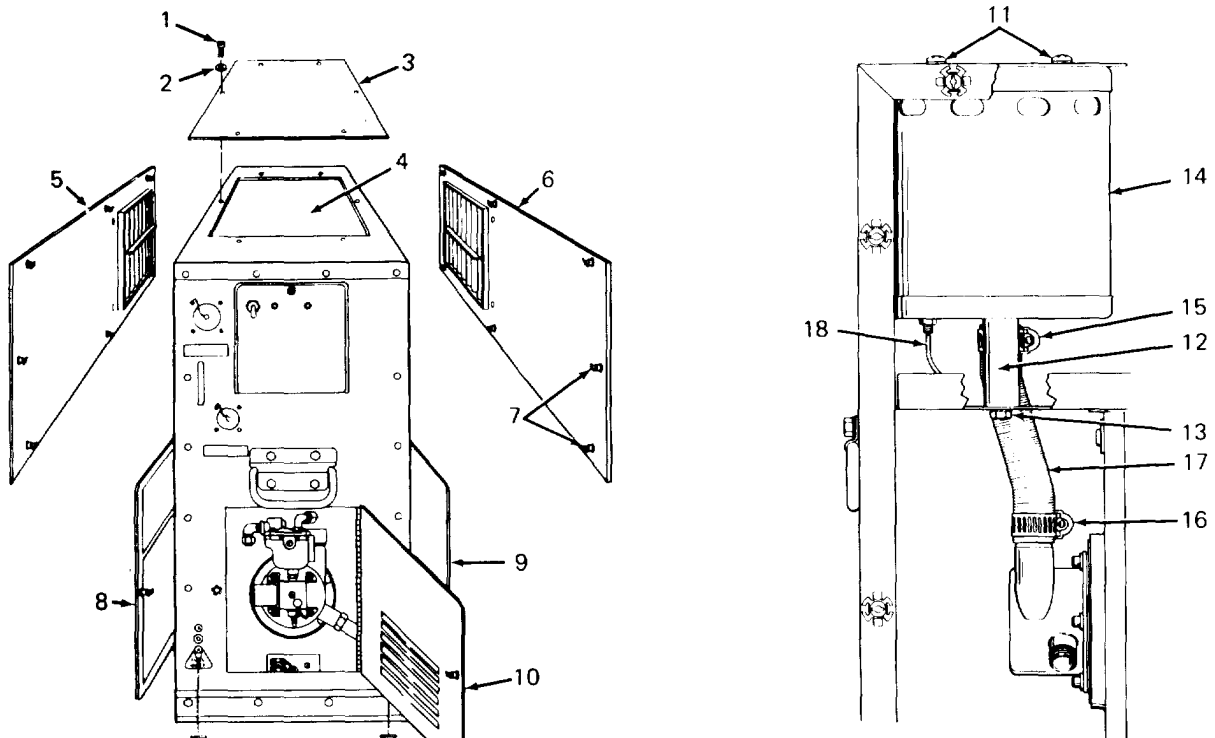

9. Check soldered connections of wires (18) at suppression capacitors for looseness or broken solder,

WARNING

Do not operate heater in enclosure unless exhaust gases are piped outside. Exhaust gases contain carbon monoxide, a colorless, odorless, deadly poisonous gas. Failure to provide proper elimination of the exhaust can cause severe illness or death.

10. Operate heater and listen for slow motor operation and noise indicating possible failure in motor bearings.
11. If repair is needed other than tightening screws and clamps, forward heater to intermediate maintenance.
12. Install louver panels (5 and 6) by locking eight studs (7) at each panel.
13. Reach through heater case opening (4) and connect louver linkages to louvers.
14. Install bottom cover (3) using six screws (1) and lock washers (2).

INSPECT VENTILATING AIR MOTOR

TOOLS: Tool kit, service, refrigeration unit
NSN 5180-00-596-1474

MATERIALS/PARTS: Butt connector (1)

GENERAL SAFETY INSTRUCTIONS:

Power off.
Heater cool.

INSPECTION:

WARNING

Death or serious injury could occur if precautions are not taken when maintaining this equipment. Position HEATER-OFF-FAN switch to OFF, remove power cable plug from POWER RECEPTACLE, and ground capacitors C 1 and C2 prior to gaining access to heater compartments. Terminals of capacitors are accessible at end cover of combustion blower. Always have another person standing by who is trained in electric shock first aid.

Remove electrical charge from ventilating air motor capacitor C3 by shorting out contacts using tool having insulated handle.

Allow sufficient time for heater to cool to room temperature before gaining access to heater compartments.

1. Remove six screws (1) and lock washers (2).
Lift off bottom cover (3).
2. Reach through heater case opening (4) and disconnect louver linkages from louvers.
3. Remove louver panels (5 and 6) by unlocking eight studs (7) at each panel.

INSPECT VENTILATING AIR MOTOR (CONT)

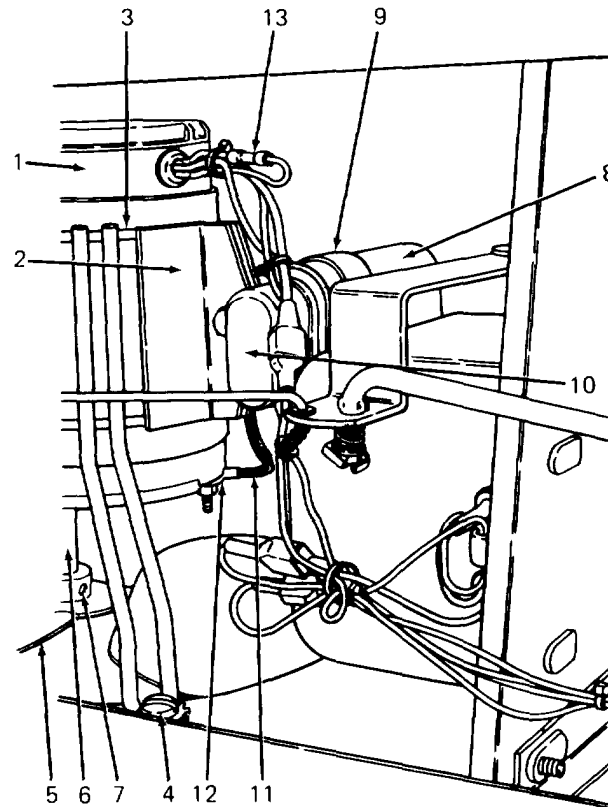

4. Check ventilating air motor (1) for secure mounting in motor mount (2)
5. Check motor cushion (3) for placement under motor mount (2) and for wear or other damage.
6. Check motor mount attaching screws (4) for security.
7. Be sure that fan blades (5) are securely mounted on motor shaft (6)- Fan blades are secured by 2 set screws (7) spaced 90° apart.
8. Check capacitor (8) for security in mounting bracket (9).
9. Check capacitor boot (10) for damage and deterioration. Be sure boot covers capacitor terminals.
10. Check ground wire (11) for loose terminals (12) and for security.
11. Check for security of wire terminals and butt connector (13). Loose terminal or butt connector must be replaced.

INSPECT VENTILATING AIR MOTOR (CONT)

WARNING

Do not operate heater in enclosure unless exhaust gases are piped outside. Exhaust gases contain carbon monoxide, a colorless, odorless, deadly poisonous gas. Failure to provide proper elimination of the exhaust can cause severe illness or death.

12. Operate heater and listen for slow motor operation and noise indicating possible failure in motor bearing.
13. If repair is needed other than tightening screws and nuts, forward heater to intermediate maintenance.
14. Install louver panels (5 and 6) by locking eight studs (7) at each panel.
15. Reach through heater case opening (4) and connect louver linkages to louvers.
16. Install bottom cover (3) using six screws (1) and lock washers (2).

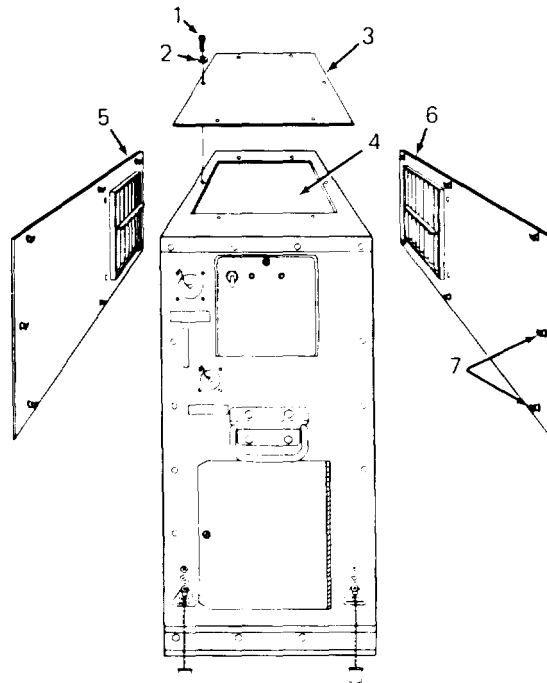

INSPECT/TEST/REMOVE/INSTALL SAFETY THERMOSTATS AND FLAME SWITCH AND BRACKET ASSEMBLY

TOOL EQUIPMENT: Volt ohmmeter
Thermometer [range up to 300° F (49°C)]

TOOLS: Tool kit, service, refrigeration unit
NSN 5180-00-596-1474

MATERIALS/PARTS: Wire, insulated, heat resistant

GENERAL SAFETY INSTRUCTIONS:

Power off.
Heater cool.

INSPECTION:**WARNING**

Death or serious injury could occur if precautions are not taken when maintaining this equipment. Position HEATER-OFF-FAN switch to OFF, remove power cable plug from POWER RECEPTACLE, and ground capacitors C1 and C2 prior to gaining access to heater compartments. Terminals of capacitors are accessible at end cover of combustion blower. Always disconnect power cable before making continuity tests or before repairing heater. Always have another person standing by who is trained in electric shock first aid.

Allow sufficient time for heater to cool to room temperature before gaining access to heater compartments.

1. Open access door (1) by unlocking one stud (2). Locate thermostat mounting bracket (3) and flame switch and bracket assembly (4).
2. Remove two screws (5) and lock washers (6) at mounting bracket (3) and lift out bracket and overheat thermostat (7). The thermostat is covered by shield (8).
3. Check thermostat (7) for cracks, dents, or other signs of damage or overheating.
4. Check for bent or missing shield (8).
5. Check terminal connections of wires (9) for good electrical contact.
6. Replace defective thermostat (7).
7. Remove two screws (10) and lock washers (11) and lift out flame switch and bracket assembly (4). Assembly (4) carries overheat thermostat (12) which is identical to thermostat (7).

INSPECT/TEST/REMOVE/INSTALL SAFETY THERMOSTATS AND FLAME SWITCH AND BRACKET ASSEMBLY (CONT)

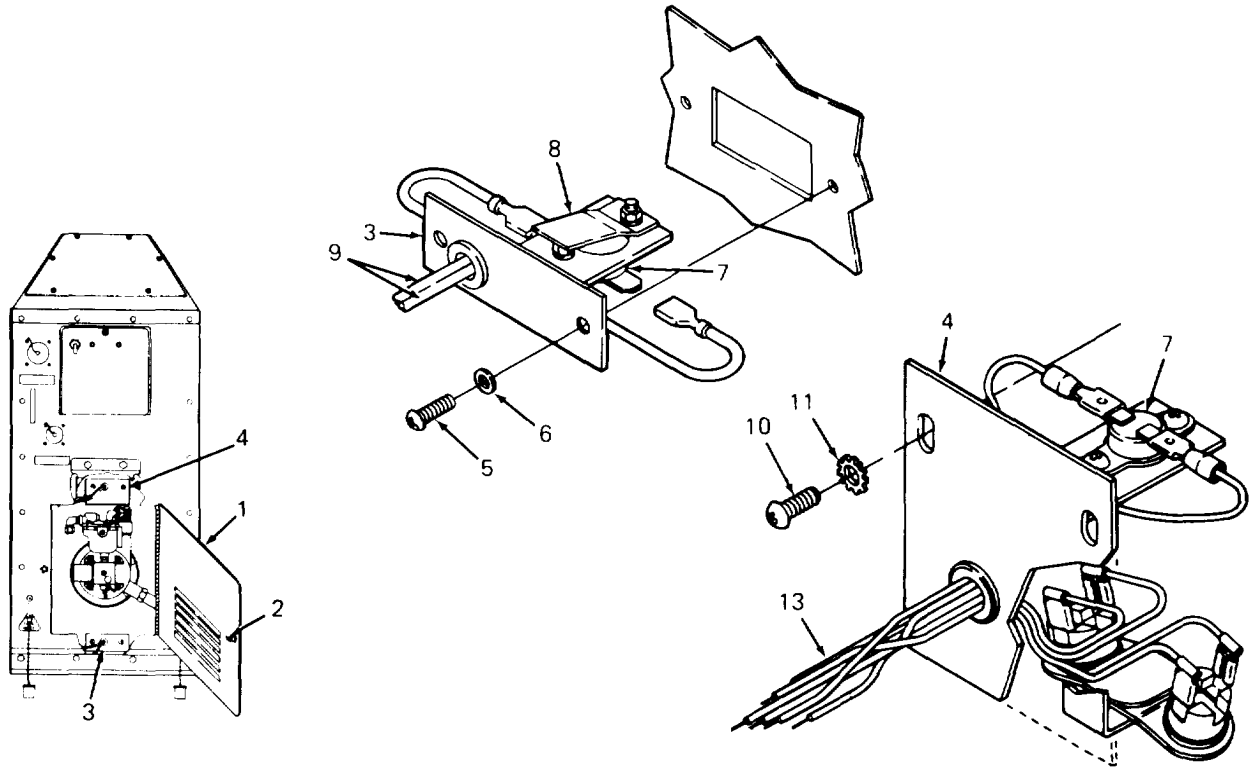

8. Check thermostat (12) for cracks, dents, or other signs of damage or overheating.
9. Check flame switch and bracket assembly (4) for bends, broken welds, and damage to flame switches (13 and 14).
10. Check terminal connections of wires (15) for good electrical contact.
11. Replace defective thermostat (12) or flame switch and bracket assembly (4).

TESTING:

1. Test both overheat thermostats according to the same procedure as follows:

- a. Disconnect quick disconnect terminals (1) of wires (2) from thermostat (3).
- b. Connect terminals (4) of thermostat (3) in series with volt ohmmeter using heat resistant, insulated wires.
- c. Place thermostat in heating chamber along with accurate thermometer.
- d. Thermostat contacts must open between 253° and 267° F (123° and 131°C). Turn off heat and allow thermostat to cool. Thermostat contacts must close between 227° and 243° F (108° and 117°C). Replace thermostat that fails to operate within these limits.

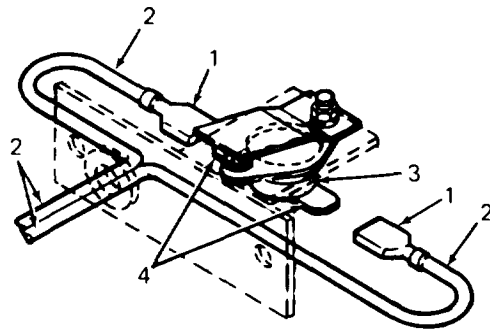

INSPECT/TEST/REMOVE/INSTALL SAFETY THERMOSTATS AND FLAME SWITCH AND BRACKET ASSEMBLY (CONT)

2. Test flame switch and bracket assembly for continuity.

- a. Disconnect red and violet wires from flame switch (1). Using volt ohmmeter, place one probe against each terminal of flame switch (1). Meter should indicate zero resistance.
- b. Heat bottom of flame switch (1) to 130' F (54° C) and place probes on terminals. Switch should snap (open) and meter should indicate infinite resistance.
- c. Connect red and violet wires to flame switch (1).
- d. Disconnect red and brown wires from flame switch (2). Using volt ohmmeter, place one probe against each terminal of flame switch (2). Meter should indicate infinite resistance,
- e. Heat bottom of flame switch (2) to 130° F (54° C) and place probes on terminals. Switch should snap (close) and meter should indicate zero resistance.
- f. Connect red and brown wires to flame switch (2).
- g. If either flame switch (1 or 2) is defective, replace flame switch and bracket assembly.

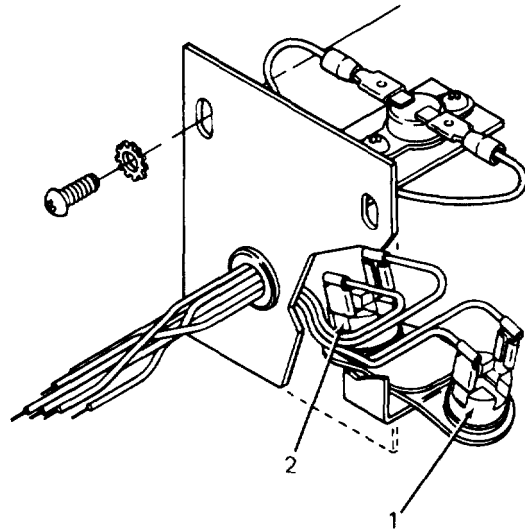

REMOVAL:

1. Remove lower overheat thermostat as follows:

- a. Remove two screws (1) and lock washers (2) at thermostat mounting bracket (3) and lift out bracket and thermostat (4). Thermostat is covered by shield (5).
- b. Disconnect red/white and grey wires (6 and 7) from thermostat (4) at quick disconnect terminals (8).
- c. Remove two screws (9), lock washers (10), and nuts (11) securing thermostat (4) to mounting bracket (3). One screw/lock washer/ nut combination secures shield (5) to lower thermostat. Retain shield for reassembly. Lift off thermostat (4).

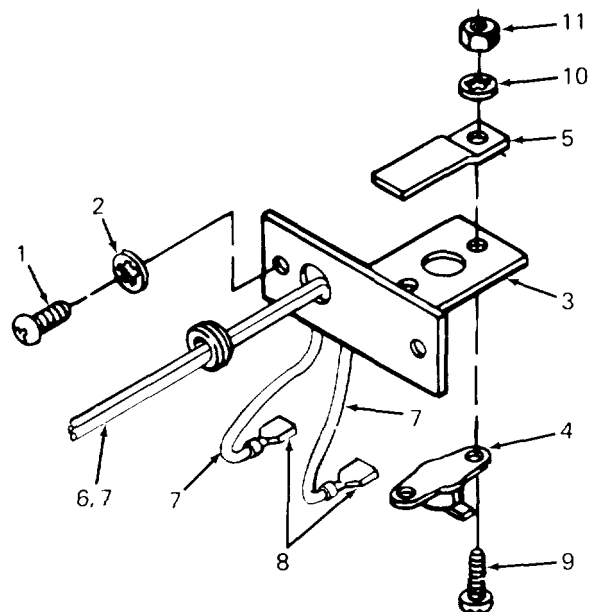

INSPECT/TEST/REMOVE/INSTALL SAFETY THERMOSTATS AND FLAME SWITCH AND BRACKET ASSEMBLY (CONT)

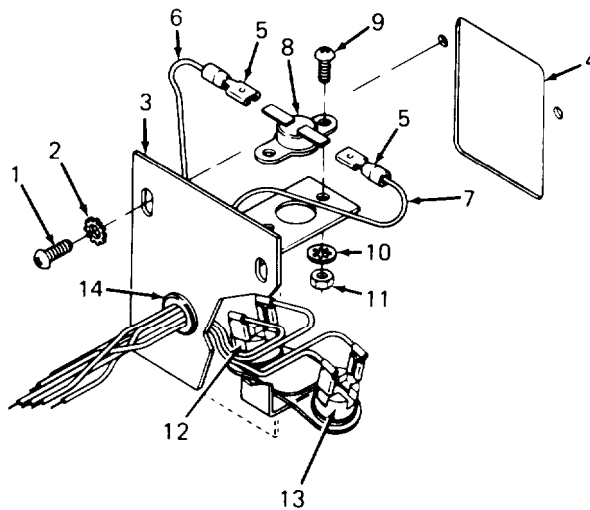

2. Remove flame switch and bracket assembly and upper overheate thermostat as follows:
 - a. Remove two screws (1) and lock washers (2). Pull flame switch and bracket assembly (3) out of opening (4) in heater bulkhead.
 - b. Disconnect quick disconnect terminals (5) of yellow and grey wires (6 and 7) from upper overheate thermostat (8).
 - c. Remove two screws (9), lock washers (10), and nuts (11). Lift off thermostat (8)
 - d. If further removal is desired, disconnect red and violet wires from flame switch (12) and red and brown wires from flame switch (13).
 - e. Pry out grommet (14) and pull wires through opening in flame switch and bracket assembly (3).

INSPECT/TEST/REMOVE/INSTALL SAFETY THERMOSTATS AND FLAME SWITCH AND BRACKET ASSEMBLY (CONT)

INSTALLATION:

1. Install lower overheats thermostat as follows:

- a. Install thermostat (4) on mounting bracket (3) using two screws (9), lock washers (10), and nuts (11). Use one screw/lock washer/nut combination to install shield (5) as illustrated.
- b. Connect wires (6 and 7) to thermostat (4) using quick disconnect terminals (8).
- c. Install thermostat (4) through mounting hole and secure thermostat mounting bracket (3) using two screws (1) and lock washers (2).

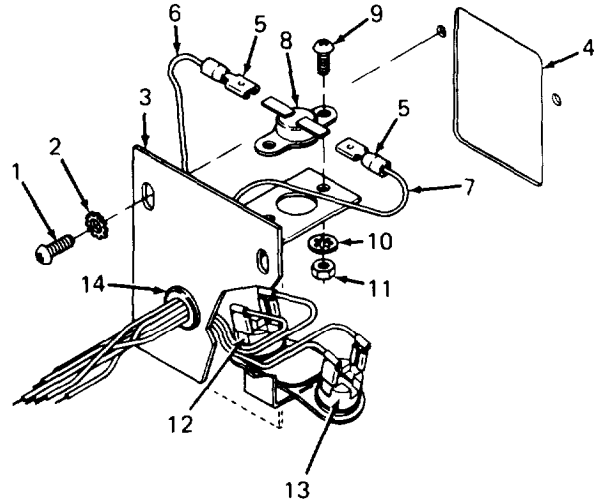

2. Install upper overheats thermostat and flame switch and bracket assembly as follows:

- a. Install thermostat (8) on flame switch and bracket assembly (3) using two screws (9), lock washers (10), and nuts (11).
- b. If wires have been removed from flame switch and bracket assembly, reinsert wires through opening in assembly.
- c. Connect red and violet wires to flame switch (12), connect red and brown wires to flame switch (13), and connect yellow and grey wires (6 and 7) to upper overheats thermostat (8) using quick disconnect terminals (5).
- d. Press grommet (14) in place.
- e. Install flame switch and bracket assembly (3) in opening (4) in heater bulkhead, Attach assembly to heater bulkhead using two screws (1) and lock washers (2). With screws loosened, adjust flame switch and bracket assembly downward as far as it will go. This seats the flame switches (12 and 13) against the heat exchanger. Tighten screws (1).

BURNER ASSEMBLY PROCEDURES INDEX

PROCEDURE	PAGE
Remove/Install/Test/Repair Ignition Transformer and Cable	3-110
Service/Test/Remove/Install Igniter Assembly	3-117

REMOVE/INSTALL/TEST/REPAIR IGNITION TRANSFORMER AND CABLE

TEST EQUIPMENT: Volt ohmmeter

TOOLS: Tool kit, service, refrigeration unit
NSN 5180-00-596-1474

MATERIALS/PARTS: Butt connector (2)

GENERAL SAFETY INSTRUCTIONS:

Power off.
Heater cool.

REMOVAL:

WARNING

Death or serious injury could occur if precautions are not taken when maintaining this equipment. Position HEATER-OFF-FAN switch to OFF, remove power cable plug from POWER RECEPTACLE, and ground capacitors C1 and C2 prior to gaining access to heater compartments. Terminals of capacitors are accessible at end cover of combustion blower. Always disconnect power cable before making continuity tests or before repairing heater. Always have another person standing by who is trained in electric shock first aid.

Remove electrical charge from ventilating air motor capacitor C3 by shorting out contacts using tool having insulated handle.

Allow sufficient time for heater to cool to room temperature before gaining access to heater compartments.

1. Remove six screws (1) and lock washers (2), Lift off bottom cover (3).
2. Reach through heater case opening (4) and disconnect louver linkages from louvers.

REMOVE/INSTALL/TEST/REPAIR IGNITION TRANSFORMER AND CABLE (CONT)

3. Remove louver panels (5 and 6) by unlocking eight studs (7) at each panel.
4. Open left door (8) by unlocking one stud (9).

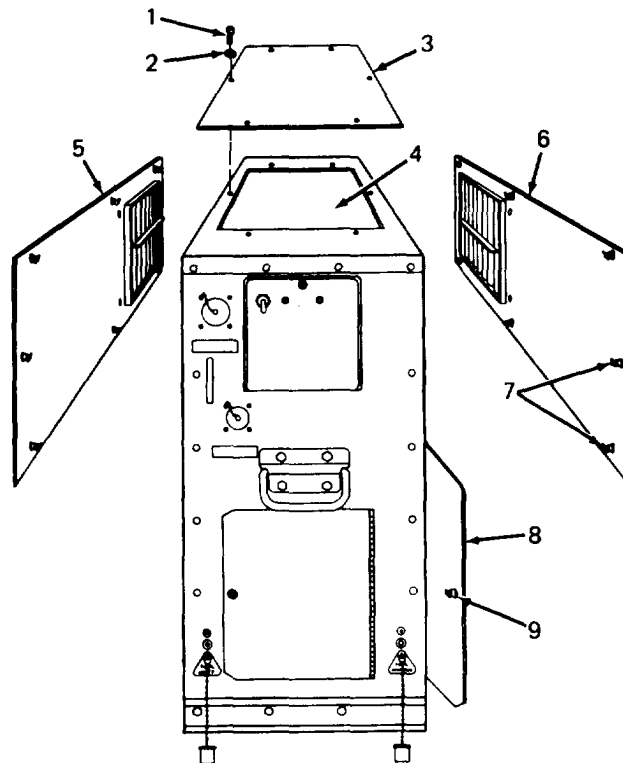

5. Disconnect ignition cable (10) from igniter (11).
6. Release cable clamp (12) by removing screw (13), lock washer (14), and nut (15).
7. Disconnect yellow and white transformer wires (16 and 17) at quick disconnect terminals (18) on yellow and white PC board assembly wires (19 and 20).

REMOVE/INSTALL/TEST/REPAIR IGNITION TRANSFORMER AND CABLE (CONT)

8. Pry grommet (26) out of hole (27) in exchanger housing bottom panel (28). Pull ignition cable (10) out through hole.
9. Remove four nuts (21), lock washers (22), and flat washers (23). Lift transformer (24) off bulkhead (25).

INSTALLATION:

1. Install transformer (24) on bulkhead (25) using four flat washers (23), lock washers (22), and nuts (21).
2. Connect yellow and white transformer wires (16 and 17) to quick disconnect terminals (18) on yellow and white PC board assembly wires (19 and 20). Connect yellow wire to yellow wire and white wire to white wire.
3. Install ignition cable (10) through hole (27) in exchanger housing bottom panel (28),
4. Connect ignition cable (10) to igniter (11).
5. Press grommet (26) into hole (27).
6. Install cable clamp (12) using screw (13), lock washer (14), and nut (15).

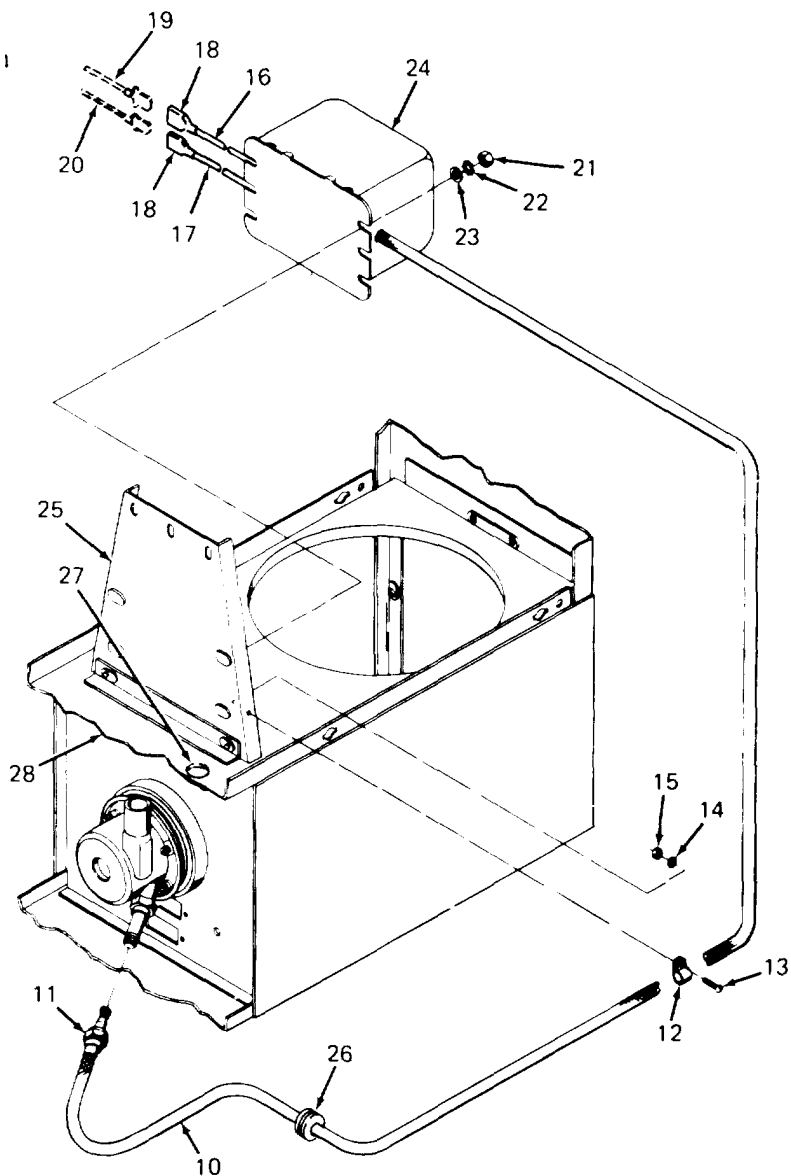

REMOVE/INSTALL/TEST/REPAIR IGNITION TRANSFORMER AND CABLE (CONT)

7. Secure left door (8) by locking one stud (9).
8. Install louver panels (5 and 6) by locking eight studs (7) at each panel.
9. Reach through heater case opening (4) and connect louver linkages to louvers.
10. Install bottom cover (3) using six screws (1) and lock washers (2).

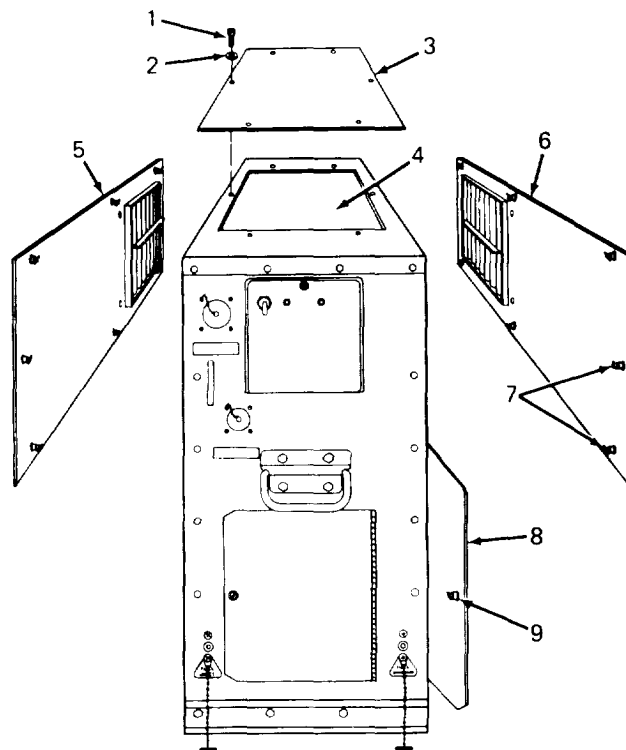

TESTING:

WARNING

Death or serious injury could occur if precautions are not taken when maintaining this equipment. Position HEATER-OFF-FAN switch to OFF, remove power cable plug from POWER RECEPTACLE, and ground capacitors C1 and C2 at end cover of combustion blower. Always have another person standing by who is trained in electric shock first aid.

1. Remove bottom cover and louver panels. Refer to REMOVAL, page 3-110.
2. Disconnect ignition cable (1) from igniter,
3. Disconnect yellow and white transformer wires (2 and 3) from quick disconnect terminals (4) on PC board assembly wires (5 and 6).
4. Using volt ohmmeter, test primary winding of transformer (7). place one probe against wire (2) and the other probe against wire (3). Meter should read 5-6 ohms.
5. Using volt ohmmeter, test secondary winding of transformer. Place one probe against spring (8) and ground other probe on transformer case or shielding of ignition cable (1). Meter should read 14,000 ohms.

REMOVE/INSTALL/TEST/REPAIR IGNITION TRANSFORMER AND CABLE (CONT)

CAUTION

When checking spark, do not allow spark gap to exceed 0.125 in. (3.175 mm). Larger gap will cause excessively high potential buildup resulting in insulation breakdown either internally or in ignition cable.

- 6. Test for spark as follows:
 - a. Disconnect ignition cable (1) from igniter assembly.

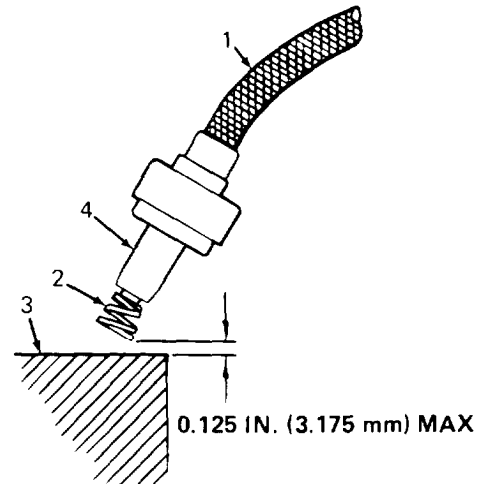

WARNING

Death or serious injury could occur if this equipment is not properly grounded before connecting to a power source. Do not attempt to operate before grounding. Always have another person standing by who is trained in electric shock first aid.

- b. Disconnect fuel pump cable from EXTERNAL FUEL PUMP RECEPTACLE and close shutoff valve at fuel container.
- c. Position spring (2) at tip of cable not more than 0.125 in. (3.175 mm) from grounded surface (3).

REMOVE/INSTALL/TEST/REPAIR IGNITION TRANSFORMER AND CABLE (CONT)

- d. Place HEATER-OFF-FAN switch in HEATER position. If *no* spark is observed, inspect connector (4) (red silicone rubber) for signs of burning or improper installation. Check the connector for any of the following illustrated conditions:

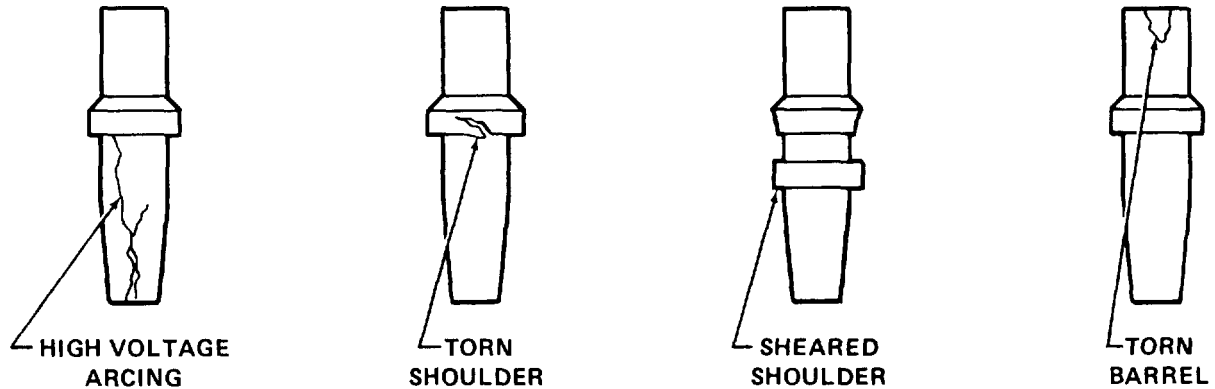

Replace defective connector using connector kit.

- e. Retest. If spark is not observed, inspect quick disconnect terminals (5) connecting wires (6 and 7) to transformer (8). Reconnect wires using new terminals if needed. If spark is still not observed, replace transformer.

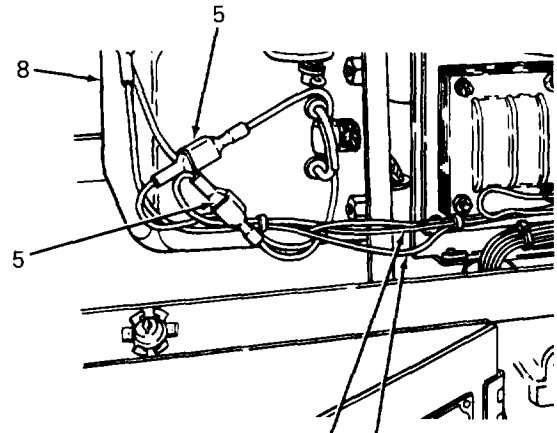
**REPAIR:**

Repair consists in replacing kitted connector parts in ignition cable connector.

WARNING

Death or serious injury could occur if precautions are not taken when maintaining this equipment. Position HEATER-OFF-FAN switch to OFF, remove power cable plug from POWER RECEPTACLE, and ground capacitors C1 and C2 at end cover of combustion blower. Always have another person standing by who is trained in electric shock first aid.

1. Disconnect ignition cable (1) from igniter assembly.
2. Unscrew spring (2) and discard.
3. Cut off stud (3) and discard.
4. Pull connector (4) out of nut (5) and discard.

REMOVE/INSTALL/TEST/REPAIR IGNITION TRANSFORMER AND CABLE (CONT)

5. Check nut (5) for stripped threads or other damage interfering with function. Check soldered connection of cable shielding to ferrule (6). If nut or shielding is defective, replace transformer assembly.
6. If bare wire is burned, has broken strands, or is otherwise damaged, slide shielding back, cut off damaged portion, and remove 0.25 in. (6.35 mm) of insulation.

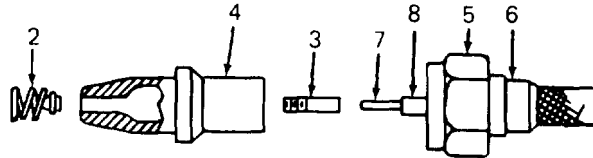

7. Pinch or twist bare wires (7) into small bundle and install stud (3) over wires.



Do not crimp threaded part of stud (3) when attaching stud to wires (7). Crimp only smooth part.

8. Crimp stud (3) on bare wires.
9. Push high tension wire (8) into connector (4) until threaded end of stud (3) projects beyond end of connector. Seat connector firmly in nut (5) and ferrule (6).
10. Screw spring (2) on threaded end of stud (3).

SERVICE/TEST/REMOVE/INSTALL IGNITER ASSEMBLY

TOOLS: Tool kit, service, refrigeration unit
NSN 5180-00-596-1474

MATERIALS/PARTS: Dry cleaning solvent (Item 13, Appendix E)

SERVICE:

WARNING

Death or serious injury could occur if precautions are not taken when maintaining this equipment. Position HEATER-OFF-FAN switch to OFF, remove power cable plug from POWER RECEPTACLE, and ground capacitors C1 and C2 prior to gaining access to heater compartments. Terminals of capacitors are accessible at end cover of combustion blower. Always disconnect power cable before making continuity tests or before repairing heater. Always have another person standing by who is trained in electric shock first aid.

Allow sufficient time for heater to cool to room temperature before gaining access to heater compartments.

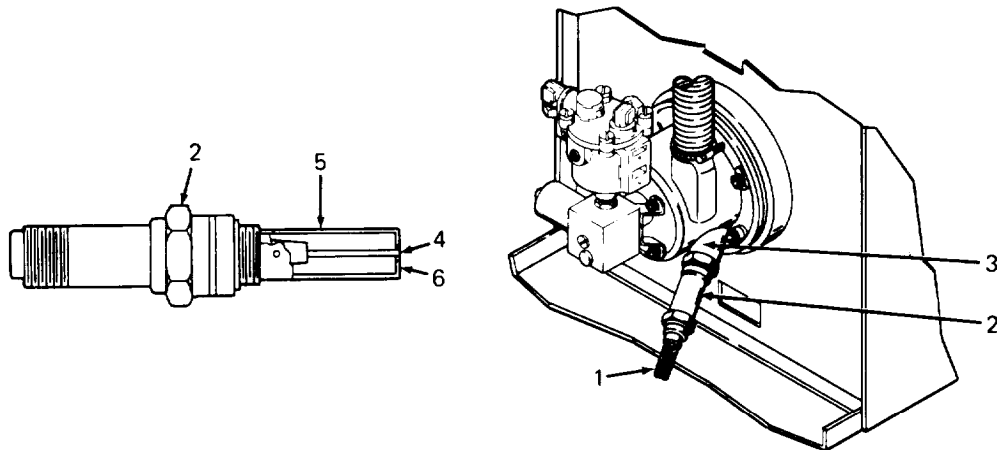

1. Disconnect ignition cable (1) from igniter assembly (2). Remove igniter assembly from burner head port (3).

SERVICE/TEST/REMOVE/INSTALL IGNITER ASSEMBLY (CONT)

WARNING

Dry cleaning solvent P-D-680 (safety or Stoddard's Solvent) is potentially dangerous. Avoid repeated and prolonged breathing of vapors and skin contact with the liquid. Do not use near open flame, arcing equipment, or other ignition sources. Always wear eye protection and protective clothing. Flash point of P-D-680 is 100° to 138° F (38° to 59° C).

Death or serious injury could occur if compressed air is directed against the skin. Do not use compressed air for cleaning or drying unless the pressure is/has been reduced to 30 psi (207 kPa) or less. When working with compressed air always use chip guards, eye protection, and other personal protective equipment.

2. Clean igniter assembly (2) in P-D-680 dry cleaning solvent. Shake off excess solvent and dry with compressed air.
3. Check electrode (4) at end of sleeve (5). It should be in center of hole in end face (6). If needed, use small screwdriver or similar tool and bend electrode slightly until it is centered.
4. End of electrode must be flush with end face (6) to 0.010 in. (0.254 mm) underflush. If igniter assembly (2) fails to meet these dimensions or is badly fouled or burned, replace.

TESTING:

CAUTION

When attaching ignition cable to igniter, tighten manually and turn nut only about 1/4 additional turn. Avoid over-tightening.

1. Connect ignition cable (1) to igniter assembly (2).
2. Block burner head port (3) by stuffing with rag or other means.
3. Disconnect fuel pump cable from EXTERNAL FUEL PUMP RECEPTACLE and close shutoff valve at fuel container.

SERVICE/TEST/REMOVE/INSTALL IGNITER ASSEMBLY (CONT)

WARNING

Death or serious injury could occur if this equipment is not properly grounded before connecting to a power source. Do not attempt to operate before grounding. Always have another person standing by who is trained in electric shock first aid.

4. Place HEATER-OFF-FAN switch in HEATER position.
5. Ground igniter assembly to heater and observe for spark. If no spark or spark is weak, replace.

REMOVAL/INSTALLATION:

Always disconnect ignition cable (1) before removing igniter assembly (2) . Igniter is threaded into port (3). Clockwise rotation tightens igniter and counterclockwise rotation loosens it.

ACCESSORY ITEMS PROCEDURES INDEX

PROCEDURE	PAGE
Test/Adjust/Remove/Install Room Thermostat	3-120
Remove/install Side Heater Case Covers	3-123
Remove/Install Power, Fuel Pump, and Room Thermostat Plugs	3-124

TEST/ADJUST/REMOVE/INSTALL ROOM THERMOSTAT

TEST EQUIPMENT: Volt ohmmeter

TOOLS: Tool kit, service, refrigeration unit
NSN 5180-00-596-1474

GENERAL SAFETY INSTRUCTIONS:

Power off.

TESTING:

WARNING

Death or serious injury could occur if precautions are not taken when maintaining this equipment. Position HEATER-OFF-FAN switch to OFF, remove power cable plug from POWER RECEPTACLE, and ground capacitors C1 and C2 at end cover of combustion blower. Always have another person standing by who is trained in electric shock first aid.

1. Disconnect thermostat cable from ROOM THERMO receptacle.
2. Remove screw (1) at bottom of thermostat cover and pull off cover.
3. Slowly rotate adjustment knob (2) clockwise and counter-clockwise. Thermostat should click as dial is rotated past room temperature, as long as room temperature is within thermostat range.
4. If click is not heard, check continuity across switch terminals. Place probes of volt ohmmeter on switch terminals. Again rotate adjustment knob. There should be continuity when the thermostat is set above room temperature by 2°F (1.1° C) or more. There should be no continuity when it is set below room temperature by 2°F (1.1° C) or more.
5. If thermostat does not operate as described above, replace.

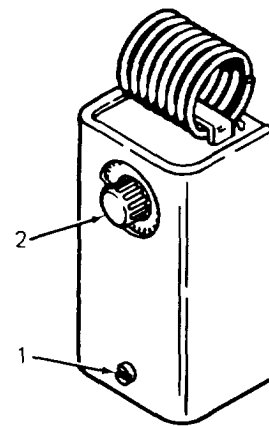

TEST/ADJUST/REMOVE/INSTALL ROOM THERMOSTAT (CONT)**ADJUSTMENT:**

Adjustment of the room thermostat is by the adjustment knob only. Do not attempt any other adjustment or repair. Improperly operating thermostat must be replaced.

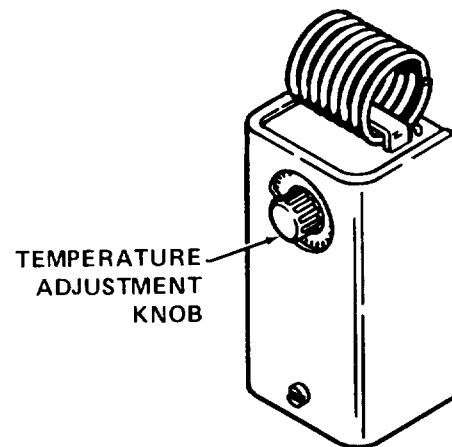
**REMOVAL:**

1. Disconnect 3-wire, 16-gauge, shielded thermostat cable from ROOM THERMO receptacle.
2. Remove screw (1) at bottom of thermostat cover and pull off cover (2).
3. Disconnect two wires (3 and 4) from terminals marked 1 and 3. Disconnect green wire (5) from screw in case marked ground.
4. Remove four mounting screws (6) and lift off thermostat (7)

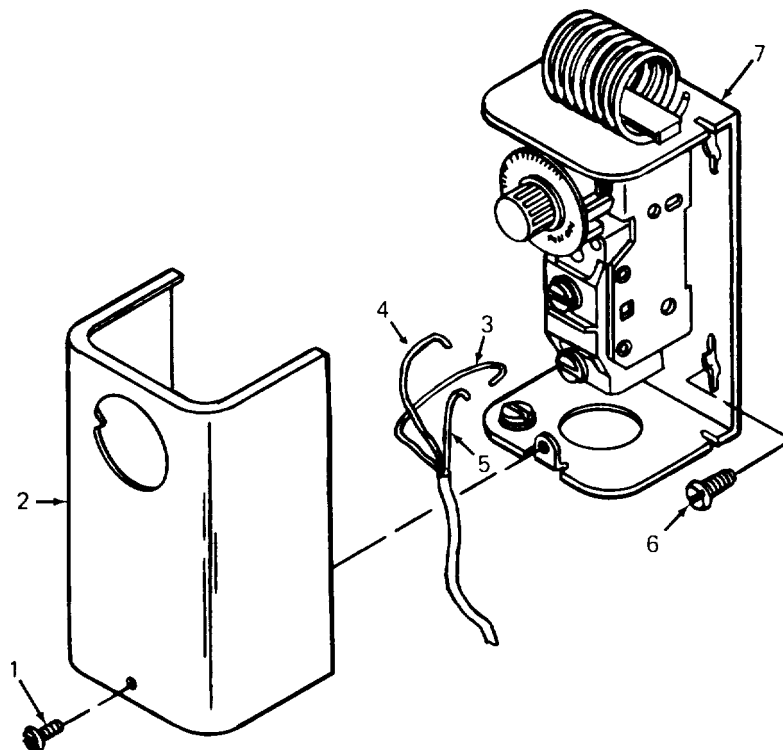

TEST/ADJUST/REMOVE/INSTALL ROOM THERMOSTAT (CONT)

INSTALLATION:

1. Install room thermostat (7) using three mounting screws (6).
2. Connect wires (3 and 4) to terminals marked 1 and 3. Connect green wire (5) to screw in thermostat case marked G R.
3. Use fourth mounting screw (6) to ground cable shield to thermostat case.
4. Install cover (2) and secure with screw (1).
5. Connect thermostat cable to ROOM THERMO receptacle.

REMOVE/INSTALL SIDE HEATER CASE COVERS

TOOLS: Tool kit, service, refrigeration unit
NSN 5180-00-596-1474

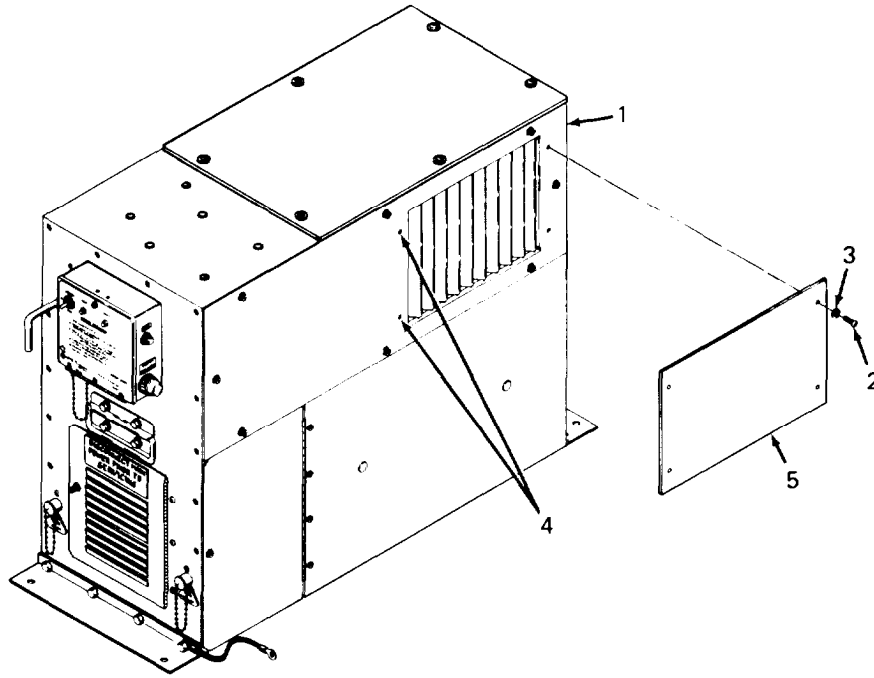

Each louver panel (1) is initially provided with four screws (2) and lock washers (3) mounted in tapped holes (4). Side covers (5) are packaged separately. The four screws and lock washers are used to mount each side cover.

REMOVAL:

1. Remove four screws (2) and lock washers (3) at each side cover (5) and lift off side cover.
2. install screws (2) and lock washers in louver panels (1).

INSTALLATION:

1. Remove four screws (2) and lock washers (3) from each louver panel (1).
2. Install side covers (5) using four screws (2) and lock washers (3) at each cover.

REMOVE/INSTALL POWER, FUEL PUMP, AND ROOM THERMOSTAT PLUGS

TOOLS: Tool kit, service, refrigeration unit
NSN 5180-00-596-1474

Solder gun kit
NSN 3439-00-930-1638

MATERIALS/PARTS: Solder (Item 12, Appendix E)

All three plugs are removed and installed in accordance with the same procedure. Plugs differ in size and number of pin contacts. The power plug (4-pin) is the largest and has an additional bushing which other plugs do not have. Once installed, it is not necessary to disassemble the bushing.

REMOVAL:

1. Disconnect plug from heater.

WARNING

Death or serious injury could occur if precautions are not taken when maintaining this equipment. Remove power cable plug from POWER RECEPTACLE. Always have another person standing by who is trained in electric shock first aid.

2. If removing power plug, first disconnect power cable from power source.

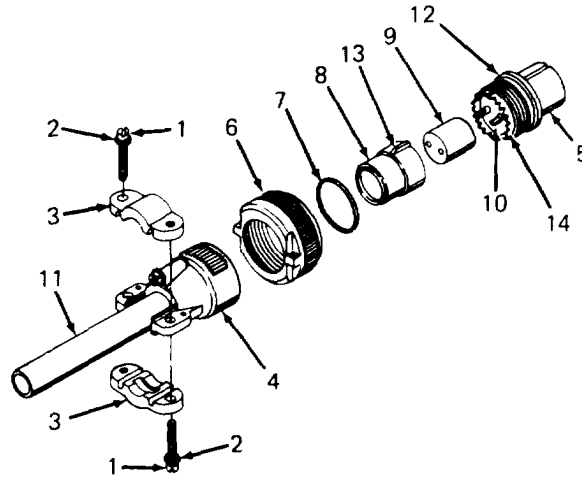

3. Remove two screws (1) and attached lock washers (2). Lift off wire clamps (3).
4. Unscrew endbell (4) from barrel (5) by rotating endbell counterclockwise.
5. Pull on barrel (5) until several inches of cable have been pulled through endbell (4)
6. Separate coupling nut (6), O-ring (7), ferrule (8), and grommet (9) from barrel (5). This exposes soldered ends of cable wires.

REMOVE/INSTALL POWER, FUEL PUMP, AND ROOM THERMOSTAT PLUGS (CONT)

7. Unsolder wires or, if plug is to be discarded, cut wires close to pin contacts (10). Slide wires out of grommet (9), ferrule (8), O-ring (7), coupling nut (6), and endbell (4). If removing power plug, wires will also be pulled through bushing (1 1).

INSTALLATION:

WARNING

Death or serious injury could occur if precautions are not taken when maintaining this equipment. Remove power cable plug from POWER RECEPTACLE. Always have another person standing by who is trained in electric shock first aid.

1. If installing power plug, be sure power cable is disconnected from power source.
2. Refer to table 3-7 and select correct cable for plug being installed.
3. If power plug is being installed, insert cable through bushing (11), endbell (4), coupling nut (6), and ferrule (8).
4. Install O-ring (7) on barrel (5) against boss (12).
5. Strip cable insulation far enough to allow individual wires to project through grommet (9) and be soldered to pin contacts (10). If installing room thermostat plug, solder small ground wire to cable shield. Insert wires at tapered end of grommet where number appears.
6. Remove 1/4 inch of insulation from individual wires (refer to table 3-7), and solder wires to correct pins.
7. Position grommet (9) with holes over pin contacts (10).
8. Slide ferrule (8) over grommet (9). Slide key (13) of ferrule into slot (14) of barrel (5).
9. Connect endbell (4) to barrel (5) by rotating endbell clockwise. Tighten firmly.
10. Push insulated portion of cable as far into endbell (4) as it will go and secure with clamps (3), screws (1), and lock washers (2).

REMOVE/INSTALL POWER, FUEL PUMP, AND ROOM THERMOSTAT PLUGS (CONT)

Table 3-7. Plug Wire Connections

Plug	Cable	Connections
Power (4-pin)	3-wire, 12-gauge	Black wire to pin A. White wire to pin C. Green wire (ground) to pin D.
Room Thermostat (3-pin)	3-wire, 16-gauge, shielded	Black and white wires to pins A and C. Green wire (ground) and shield to pin B.
Fuel Pump (2-pin)	2-wire, 16-gauge	Hot wire to pin A. Green wire (ground) to pin B.

Section VII. PREPARATION FOR STORAGE OR SHIPMENT

3-20. DISASSEMBLY OF HEATING SYSTEM.

- a. If heater is in operation, move HEATER-OFF-FAN switch to OFF. Allow heater to complete normal purge and cooling-off cycle.
- b. Disconnect exhaust line.
- c. Close fuel supply valve.
- d. Shut off 120 V ac power at power source and disconnect the 3-wire, 12-gauge cable at heater power plug. Disconnect power plug from heater and remove plug and bushing from 3-wire cable. install dust cap on receptacle,
- e. Disconnect 3-wire, 16-gauge cable and shield from room thermostat. Remove room thermostat from wall or other mounting surface.
- f. Disconnect room thermostat plug from ROOM THERMO receptacle. Remove plug from 3-wire cable. Install dust cap on ROOM THERMO receptacle.
- g. Disconnect external fuel supply cable plugs from EXTERNAL FUEL PUMP RECEPTACLE and fuel pump. Remove plugs from 2-wire, 16-gauge cable, Set aside fuel pump plug (2-pin), Install dust cap on EXTERNAL FUEL PUMP RECEPTACLE.

WARNING

Small amount of fuel may be released when disconnecting fuel lines. Collect fuel in approved safety container. Wipe up any spilled fuel promptly. Dispose of wiping cloth in safe manner.

- h. Disconnect fuel lines from FUEL INLET and FUEL OVERFLOW fittings. Install cap plugs on fittings. Disconnect fuel lines from IN and OUT ports on external fuel pump. Cover or plug ports. Remove fuel pump from mounting surface.
- i. Remove hood if installed. Place attaching screws and lock washers in box or bag, identify, and secure box or bag to hood.
- j. Support heater, if necessary, and remove mounting bolts or lag screws. Place heater on bench or table.
- k. If heater has been modified (air flow is other than downward), refer to paragraph 3-8 and restore to initial position.

3-21. PREPARATION

Prepare heater for shipment or storage as follows:

WARNING

Dry cleaning solvent P-D-680 (safety or Stoddard's Solvent) is potentially dangerous. Avoid repeated and prolonged breathing of vapors and skin contact with the liquid. Do not use near open flame, arcing equipment, or other ignition sources. Always wear eye protection and protective clothing. Flash point of P-D-680 is 100° to 138° F (38° to 59° c).

Death or serious injury could occur if compressed air is directed against the skin. Do not use compressed air for cleaning or drying unless the pressure is/has been reduced to 30 psi (207 kPa) or less. When working with compressed air always use chip guards, eye protection, and other personal protective equipment.

- a. Remove grease, oil, and fuel deposits by wiping with rags dampened with P-D-680 dry cleaning solvent. Remove excess dry cleaning solvent and dry with compressed air.
- b. Inspect painted surfaces of heater for scratches or other damage. Forward to intermediate maintenance for painting or other repair.
- c. Apply light coating of VV-L-800 preservative oil to exposed unpainted metal surfaces. Move side louvers to closed position.

d. Assemble the following items which were shipped with the heater:

- 1 Room thermostat (1)
- 1 Power plug (4-pin) (2)
- 1 Bushing (used with power plug) (3)
- 1 Room thermostat plug (3-pin) (4)
- 1 Fuel pump plug (2-pin) (5)
- 2 Side covers (6)
- 1 Fuel pump, external (optional) (7)

e. Inspect for damage. Replace damaged items.

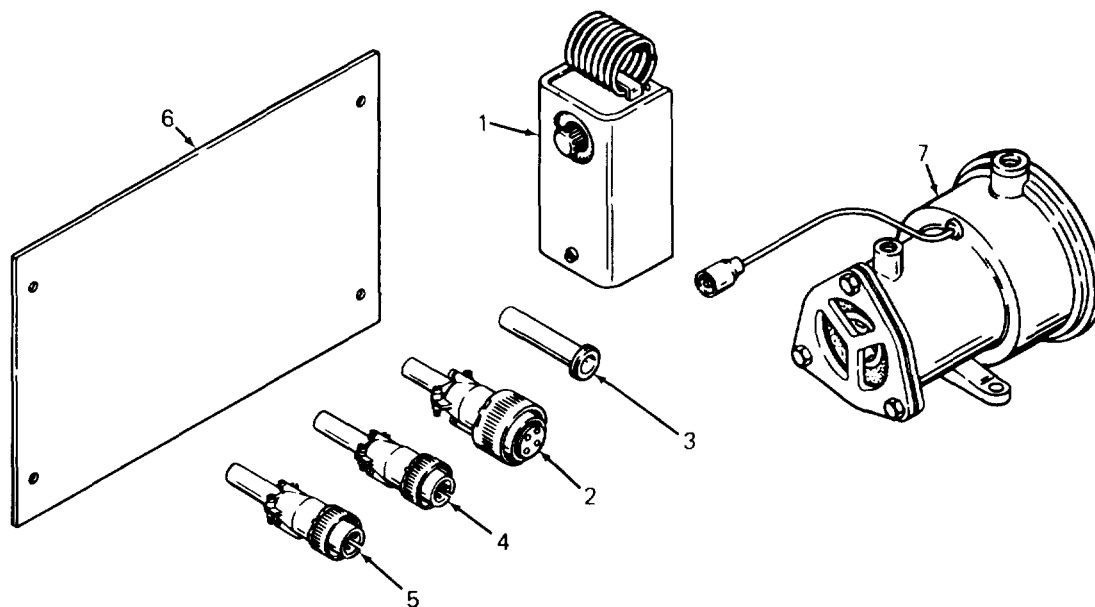

3-22. PACKAGING

- a. Obtain original shipping carton and crate, or carton and crate for shipping like heater unit.
- b. Wrap plugs, bushing, and external fuel pump sufficiently to prevent movement or damage in shipment. Place heater, plugs, bushing, and fuel pump in carton and seal.
- c. Place carton in crate and close crate securely.

CHAPTER 4
INTERMEDIATE MAINTENANCE INSTRUCTIONS

Section I. TROUBLESHOOTING

4-1. GENERAL

- a. This section contains troubleshooting information for locating and correcting most of the operating troubles which are the responsibility of intermediate maintenance. Each malfunction is followed by a list of tests or inspections which help determine probable causes and corrective actions to take.
- b. This manual cannot list all malfunctions that may occur nor all tests or inspections and corrective actions possible to correct those malfunctions. If a malfunction is not listed, or is not corrected by listed corrective actions, notify your supervisor. Only those functions that are solely within the scope of intermediate maintenance are listed.
- c. Table 4-1 lists the common malfunctions which you may find during operation or maintenance of the heater or its components. Perform tests/inspections and corrective actions in the order listed.
- d. Table 4-1 assumes that all applicable unit maintenance troubleshooting has been performed, but the cause of the malfunction has not been determined.

NOTE

Before you use this table, be sure you have performed all applicable operating procedures.

Table 4-1. Intermediate Maintenance Troubleshooting

WARNING

Death or serious injury could occur if precautions are not taken when maintaining this equipment. Position HEATER-OFF-FAN switch to OFF, remove power cable plug from POWER RECEPTACLE, and ground capacitors C1 and C2 prior to gaining access to heater compartments. Terminals of capacitors are accessible at end cover of combustion blower. Always disconnect power cable before making continuity tests or before repairing heater. Always have another person standing by who is trained in electric shock first aid.

Remove electrical charge from ventilating air motor capacitor C3 by shorting out contacts using tool having insulated handle.

Allow sufficient time for heater to cool to room temperature before gaining access to heater compartments.

NOTE

All procedural instructions assume that appropriate access openings have been uncovered to perform the procedure described. Access to heater compartments is achieved as follows:

Open left door (1), front access door (2), and right door (3) by unlocking one stud (4) at each door. Open control box cover (5) by unlocking one stud (4).

Remove six screws (6) and lock washers (7) and lift off bottom cover (8). Reach through heater case opening (9) and disconnect louver linkages from louvers.

Remove right-hand louver panel (10) and left-hand louver panel (11) by unlocking eight studs (12) at each panel.

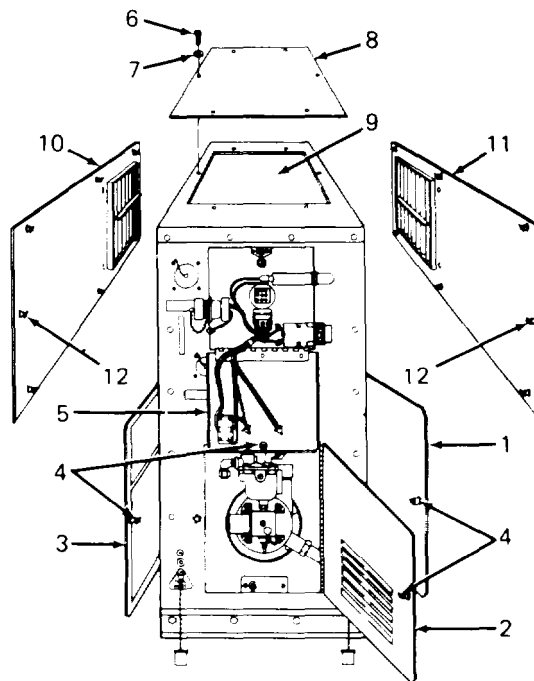

Table 4-1. Intermediate Maintenance Troubleshooting – Continued

MALFUNCTION	TEST OR INSPECTION	CORRECTIVE ACTION
-------------	--------------------	-------------------

WARNING

Death or serious injury could occur if precautions are not taken when maintaining this equipment. Position HEATER-OFF-FAN switch to OFF, remove power cable plug from POWER RECEPTACLE, and ground two capacitors at end cover of combustion blower housing before preparing for any test, check, or when disassembling a component. Disconnect fuel solenoid before connecting power cable and turning heater on for tests or checks. Always have another person standing by who is trained in electric shock first aid.

1. COMBUSTION BLOWER FAILS TO OPERATE.

Step 1. Check for loss of power to combustion blower and housing assembly, Be sure all electrical connections are secure, Connect volt ohmmeter to expose ends of capacitors at end of housing. Plug power cable into POWER RECEPTACLE and move HEATER-OFF-FAN switch quickly from OFF to HEATER to OFF while observing meter. Meter should indicate at least 110 V ac.

If no power indicated, proceed to step 2.

Step 2. Disconnect yellow and white wires (1 and 2) from combustion blower (3) at quick disconnect terminals (4 and 5). Check voltage across yellow and white wires back to PC board for 110 V ac. Place probes of volt ohmmeter in terminals (4 and 5) of PC board wires. Plug power cable into POWER RECEPTACLE and move HEATER-OFF-FAN switch quickly from OFF to HEATER to OFF while observing meter. Meter should indicate at least 110 V ac.

If circuit is faulty, replace PC board. Refer to REMOVE/INSTALL PC BOARD ASSEMBLY, page 4-12.

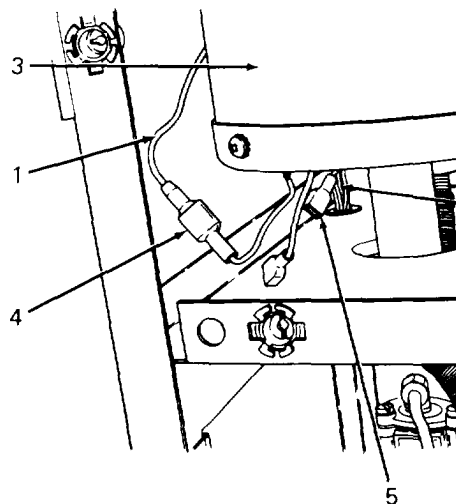

Table 4-1. Intermediate Maintenance Troubleshooting – Continued

MALFUNCTION	TEST OR INSPECTION	CORRECTIVE ACTION
	Step 3. If motor does not operate or operates slowly, check brushes, commutator, bearings, and fan assemblies.	Clean motor and replace defective parts. Refer to REPAIR BLOWER MOTOR, page 4-51.
	Step 4. Test thermal motor protector at room temperature for continuity. Meter should indicate zero resistance.	Replace defective protector. Refer to REMOVE/INSTALL/TEST THERMAL MOTOR PROTECTOR, page 4-44,
	Step 5. Test individual capacitors for continuity. Meter should indicate zero resistance.	Replace defective capacitors. Refer to REMOVE/INSTALL/TEST CAPACITORS, page 4-46.
	Step 6. Test blower motor. Refer to DISASSEMBLE/ASSEMBLE/TEST BLOWER MOTOR, TESTING, page 4-49.	If blower fails to displace at least 15 inches of water, replace blower motor. Refer to REMOVE/INSTALL COMBUSTION BLOWER AND HOUSING, page 4-40.
	Step 7. Inspect burner head for combustion deposits clogging air passages. Check condition of internal baffles.	Replace damaged burner head. No repairs, other than cleaning and replacing gasket, are authorized. Refer to REPAIR BURNER HEAD ASSEMBLY, page 4-65.

Table 4-1. Intermediate Maintenance Troubleshooting – Continued

MALFUNCTION	TEST OR INSPECTION	CORRECTIVE ACTION
-------------	--------------------	-------------------

2. VENTILATING AIR MOTOR FAILS TO OPERATE.

- Step 1. Disconnect red wire (1) from ventilating air motor (3) at quick disconnect terminal (2). Pull boot (4) away from ventilating air motor capacitor (5) and disconnect white wire (6) from capacitor. Check voltage across red and white wires back to PC board for 110 V ac. Place probes of volt ohmmeter in contact with terminal (2) of red wire and terminal of white wire. Plug power cable into POWER RECEPTACLE and move HEATER-OFF-FAN switch quickly from OFF to HEATER to OFF while observing meter. Meter should indicate at least 110 V ac.

If no current, check power source and correct if needed. If circuit is faulty, replace PC board. Refer to REMOVE/I INSTALL PC BOARD ASSEMBLY, page 4-12.

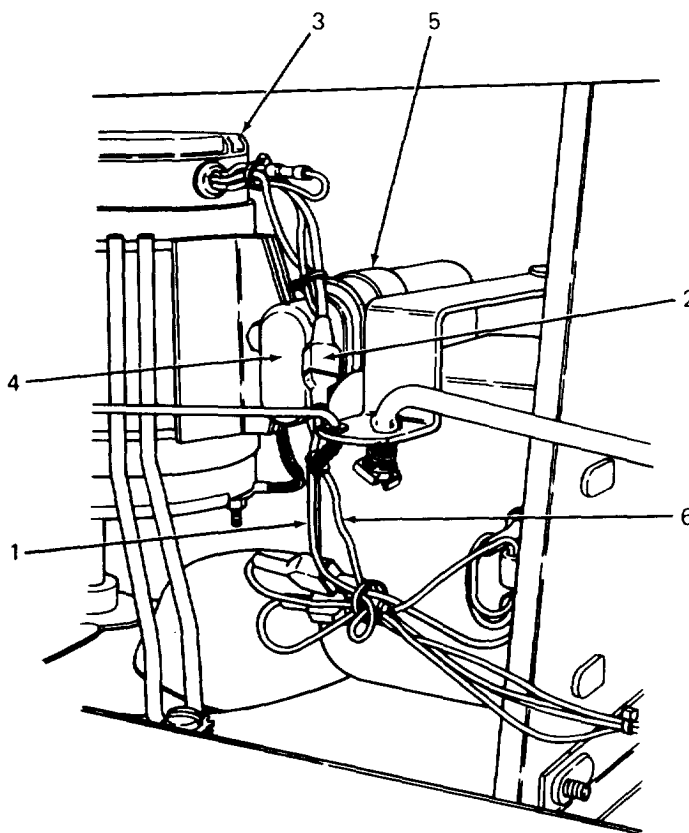
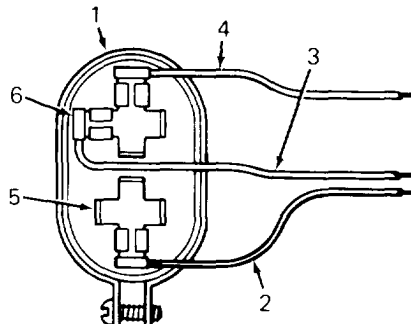

Table 4-1. Intermediate Maintenance Troubleshooting – Continued

MALFUNCTION	TEST OR INSPECTION	CORRECTIVE ACTION
-------------	--------------------	-------------------

Step 2. Test ventilating air motor capacitor, Pull capacitor boot away from end of capacitor (1). Tag and disconnect brown wire (2) and two white wires (3 and 4). Set volt ohmmeter on R x 100. Put one probe against each capacitor terminal (5 and 6). Meter should indicate infinity. Reverse probes. Reading should jump to 15,000 ohms and immediately fall back to infinity, If meter fails to react as described, capacitor is defective.



Replace defective capacitor (1). Loosen screw (7) and pull capacitor out of mounting bracket (8). Slide new capacitor into mounting bracket, tighten screw, and connect brown wire (2) and two white wires (3 and 4) to capacitor. Position boot over end of capacitor.

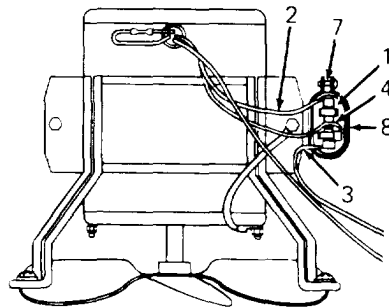

Table 4-1. Intermediate Maintenance Troubleshooting – Continued

MALFUNCTION	TEST OR INSPECTION	CORRECTIVE ACTION
-------------	--------------------	-------------------

3. VENTILATING AIR MOTOR APPEARS TO SLOW DOWN.

Step 1. Disconnect red wire (1) from ventilating air motor (3) at quick disconnect terminal (2). Pull boot (4) away from ventilating air motor capacitor (5) and disconnect white wire (6) from capacitor. Check voltage across red and white wires back to PC board for 110 V ac. Place probes of volt ohmmeter in contact with terminal (2) of red wire and terminal of white wire. Plug power cable into POWER RECEPTACLE and move HEATER-OFF-FAN switch quickly from OFF to HEATER to OFF while observing meter. Meter should indicate at least 110 V ac.

If voltage is less than 110 V ac, correct power source.

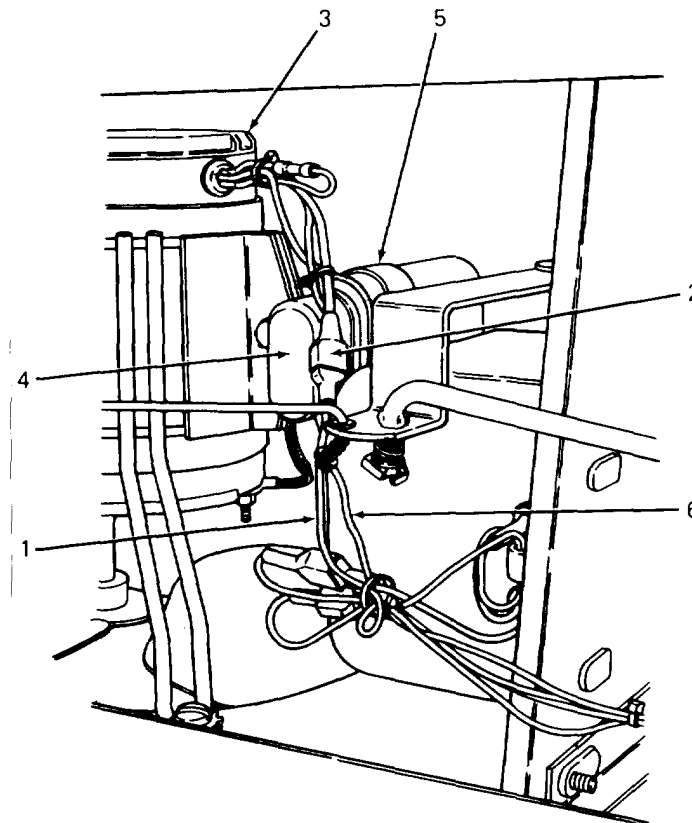
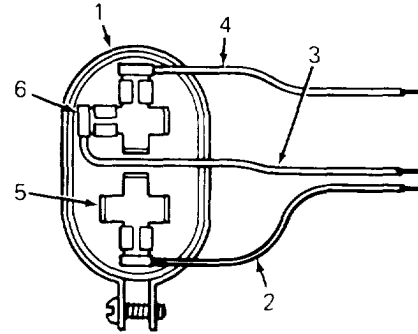

Table 4-1. Intermediate Maintenance Troubleshooting – Continued

MALFUNCTION	TEST OR INSPECTION	CORRECTIVE ACTION
-------------	--------------------	-------------------

Step 2. Test ventilating air motor capacitor. Pull capacitor boot away from end of capacitor (1). Tag and disconnect brown wire (2) and two white wires (3 and 4). Set volt ohmmeter on R x 100. Put one probe against each capacitor terminal (5 and 6). Meter should indicate infinity, Reverse probes. Reading should jump to 15,000 ohms and immediately fall back to infinity, If meter fails to react as described, capacitor is defective.



Replace defective capacitor (1). Loosen screw (7) and pull capacitor out of mounting bracket (8). Slide new capacitor into mounting bracket, tighten screw, and connect brown wire (2) and two white wires (3 and 4) to capacitor. Position boot over end of capacitor.

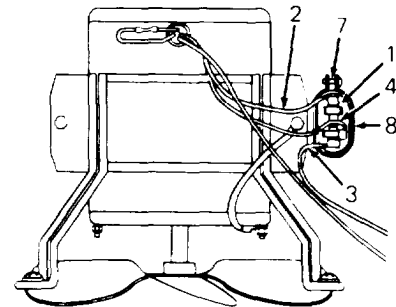

Step 3. Test ventilating air motor. Disconnect red wire (1) of motor (2) from red wire (3) of PC board (4). Connect ac ammeter (5) in series with red wires (1 and 3). Turn HEATER-OFF-FAN switch to FAN. With motor (2) operating under fan load, current draw shall not exceed 5.4 amperes. Check motor speed with tachometer. Motor speed should be 2950 rpm at 50 Hz and 3500 rpm at 60 Hz.

If current draw is too high or motor speed is low, and capacitor is good, replace motor. No repair is authorized. Refer to REMOVE/INSTALL VENTILATING AIR MOTOR, page 4-53.

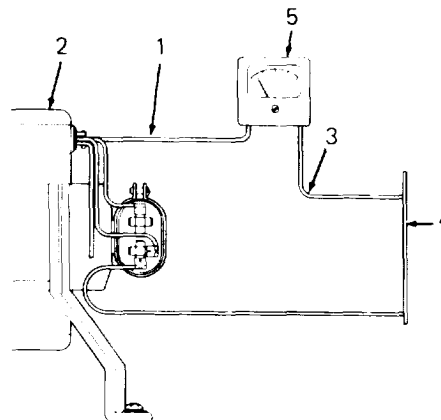

Table 4-1. Intermediate Maintenance Troubleshooting – Continued

MALFUNCTION	TEST OR INSPECTION	CORRECTIVE ACTION
-------------	--------------------	-------------------

4. HEATER BACKFIRES.

NOTE

Operation of heater with highly volatile fuels can cause percolation of fuel. Popping or backfiring occurs as bubbles pass through fuel jet. Certain types of gasoline can cause this. If possible, operate heater with another type of fuel before proceeding.

Step 1. Check heat exchanger insulators behind burner head adapter ring. Remove burner head assembly to gain access to insulators. Refer to REMOVE/I INSTALL BURNER HEAD ASSEMBLY, page 4-62.

Replace frayed, torn, or otherwise damaged insulators. Pull out damaged insulators and insert new ones. Insulators are flexible and split to facilitate installation.

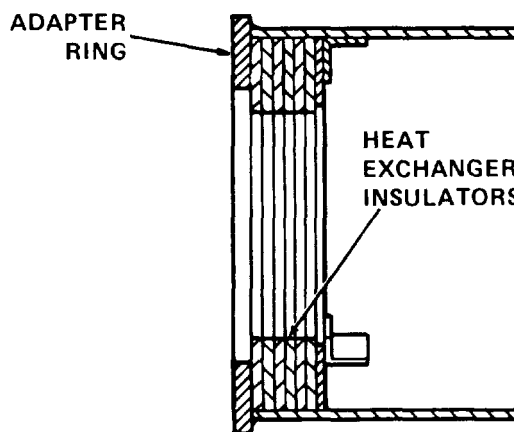

Step 2. Check combustion blower motor operation. If motor appears to run slower than normal, check brushes, commutator, bearings, and fan assemblies.

Clean motor and replace defective parts. Refer to REPAIR BLOWER MOTOR, page 4-51.

Step 3. Test blower motor. Refer to DISASSEMBLE/ASSEMBLE/TEST BLOWER MOTOR, TESTING, page 4-49.

If blower fails to displace at least 15 inches of water, replace blower motor. Refer to REMOVE/I INSTALL COMBUSTION BLOWER AND HOUSING, page 4-40.

5. HEATER OPERATES NORMALLY BUT HEAT OUTPUT REDUCED

Remove burner head assembly and visually check inside heat exchanger for excessive carbon buildup. Refer to REMOVE/I INSTALL BURNER HEAD ASSEMBLY, REMOVAL, page 4-62.

Clean heat exchanger. Refer to CLEAN/I INSPECT/REPAIR HEAT EXCHANGER, CLEANING, page 4-72.

Table 4-1. Intermediate Maintenance Troubleshooting – Continued

MALFUNCTION	TEST OR INSPECTION	CORRECTIVE ACTION
-------------	--------------------	-------------------

6. HEATER OPERATES NORMALLY BUT AIR FLOW REDUCED.

Check vertical adjustment of fan blades.

Hold or block motor (1) and loosen two screws (2). Adjust motor vertically in motor mount (3) until one-third of depth of fan blades (4) projects below flange of opening in exchanger housing bottom panel (5). Make measurement by eye.

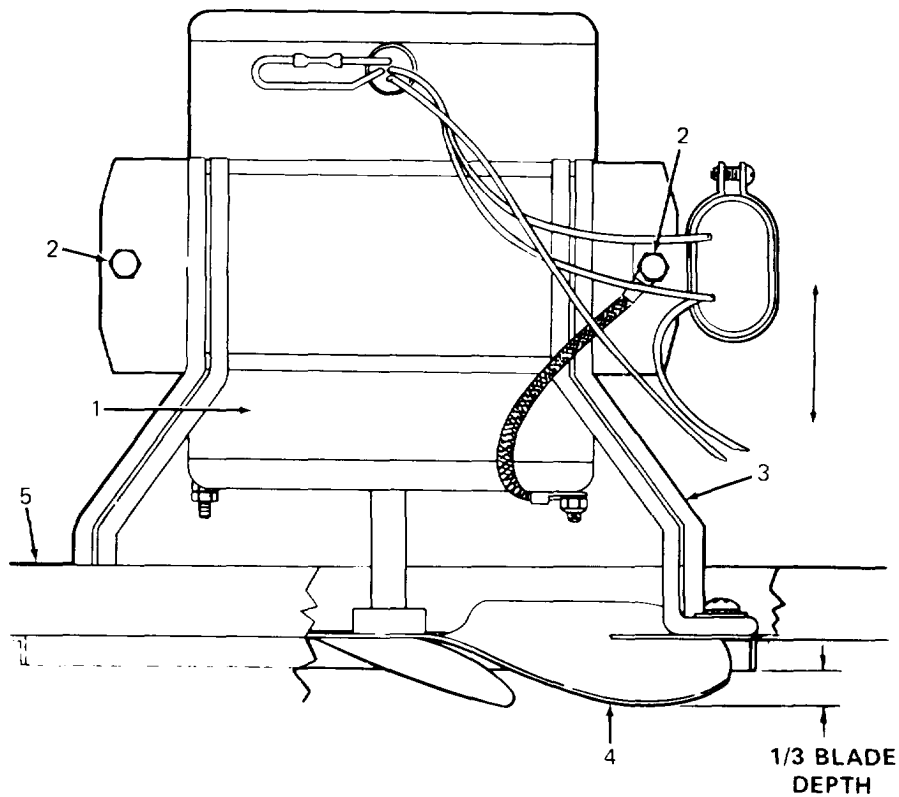

7. HEATER IGNITES BUT RESET CIRCUIT BREAKER REPEATEDLY TRIPS OR HEATER FAILS TO IGNITE BUT RESET CIRCUIT BREAKER DOES NOT TRIP (FLAME SWITCH AND BRACKET ASSEMBLY AND RESET CIRCUIT BREAKER GOOD).

Either condition indicates faulty safety shut-down circuit,

Replace PC board. Refer to REMOVE/INSTALL PC BOARD ASSEMBLY, page 4-12.

Section II. MAINTENANCE PROCEDURES

INDEX

	Page		Page
Blower Motor	4-47	Printed Circuit (PC) Board	4-12
	4-51	Assembly	4-26
– Burner Head Assembly	4-62	Printed Circuit (PC) Board	
	4-64	Assembly Wiring Receptacle	4-21
Capacitors	4-46	Printed Circuit (PC) Board	
Combustion Blower and Housing	4-40	Assembly Wiring Terminals	4-24
Heater Case Assembly	4-33	Shields and Shield Insulator	4-37
	4-35	Thermal Motor Protector	4-44
Heat Exchanger	4-67	Ventilating Air Motor	4-53
	4-72		4-58
Painted Surfaces	4-39	Ventilating Air Motor Capacitor	4-60

4-2. GENERAL INSTRUCTIONS

Maintenance instructions in this section will list resources required, personnel required, and equipment condition for the start of the procedure. Note the following:

- Resources required are not listed unless they apply to the procedure.
- Personnel required are listed only if the task requires more than one. If PERSONNEL is not listed, it means one person can do the task.
- The normal standard equipment condition to start a maintenance task is heater shut down and at room temperature. EQUIPMENT CONDITION is not listed unless some other condition is required besides power off and equipment cooled.

PRINTED CIRCUIT (PC) BOARD ASSEMBLY PROCEDURES INDEX

PROCEDURE	PAGE
Remove/install PC Board Assembly	4-12
Repair PC Board Assembly Wiring Receptacle	4-21
Repair PC Board Assembly Wiring Terminals	4-24
Repair PC Board Assembly Harness Receptacle and Plug	4-26.1
Test PC Board Assembly	4-26.4

REMOVE/INSTALL PC BOARD ASSEMBLY

TOOLS: Tool kit, service, refrigeration unit
NSN 5180-00-596-1474

MATERIALS/PARTS: Sealant (Item 10, Appendix E)

GENERAL SAFETY INSTRUCTIONS:

- Power off.
- Heater cool.

REMOVAL:

WARNING

Death or serious injury could occur if precautions are not taken when maintaining this equipment. Position HEATER-OFF-FAN switch to OFF, remove power cable plug from POWER RECEPTACLE, and ground capacitors C1 and C2 prior to gaining access to heater compartments. Terminals of capacitors are accessible at end cover of combustion blower. Always have another person standing by who is trained in electric shock first aid.

Allow sufficient time for heater to cool to room temperature before gaining access to heater compartments.

1. Open control box cover(1), front access door (2), and right side door (3) by unlocking studs (4, 5, and 6)

REMOVE/INSTALL PC BOARD ASSEMBLY (CONT)

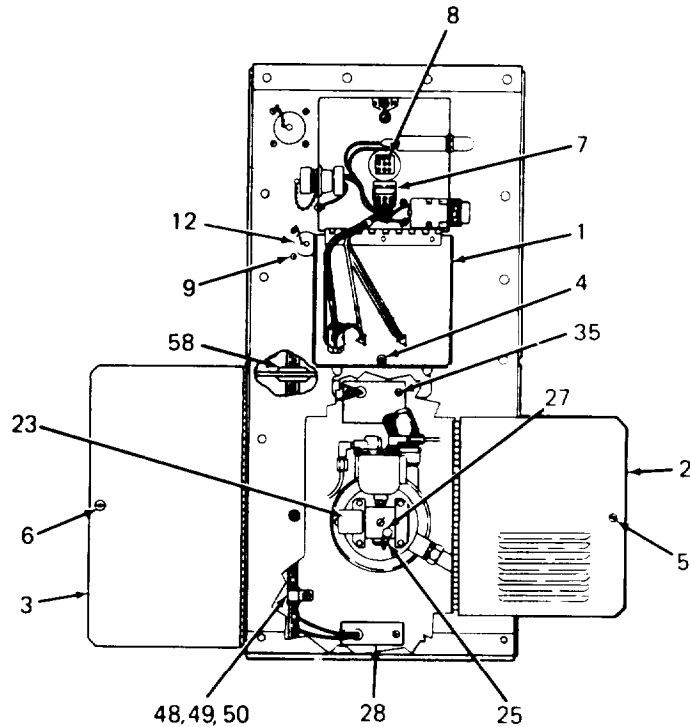

2. Disconnect control box harness plug (7) from PC board wiring receptacle (8). Depress locking tabs and pull receptacle out of mounting hole from inside heater case.
3. Remove four screws (9), lock washers (10), and nuts (11) and lift out EXTERNAL FUEL PUMP RECEPTACLE (12) from inside heater case. One screw (9), lock washer (10), and nut (11) also attaches dust cap and chain (13) and ground wire (14). Retain dust cap and chain.
4. Remove four screws (15), lock washers (16), and nuts (17) and lift out POWER RECEPTACLE (18) from inside heater case. One screw (15), lock washer (16), and nut (17) also attaches dust cap and chain (19) and ground wire (20). Retain dust cap and chain.

NOTE

For Model UH-68G, PC board assembly may have been replaced with PC board assembly for Model UH-68G1.

On Model UH-66G1, disconnect PC board assembly harness plug (8A) from receptacle (8 B).

NOTE

Tag all wires as they are disconnected.

On Model UH-68G, disconnect green and blue wires (21 and 22) from fuel solenoid (23). Disconnect orange wire (24) from carburetor thermostat (25). Disconnect white wire (26) from carburetor heater (27).

REMOVE/INSTALL PC BOARD ASSEMBLY (CONT)

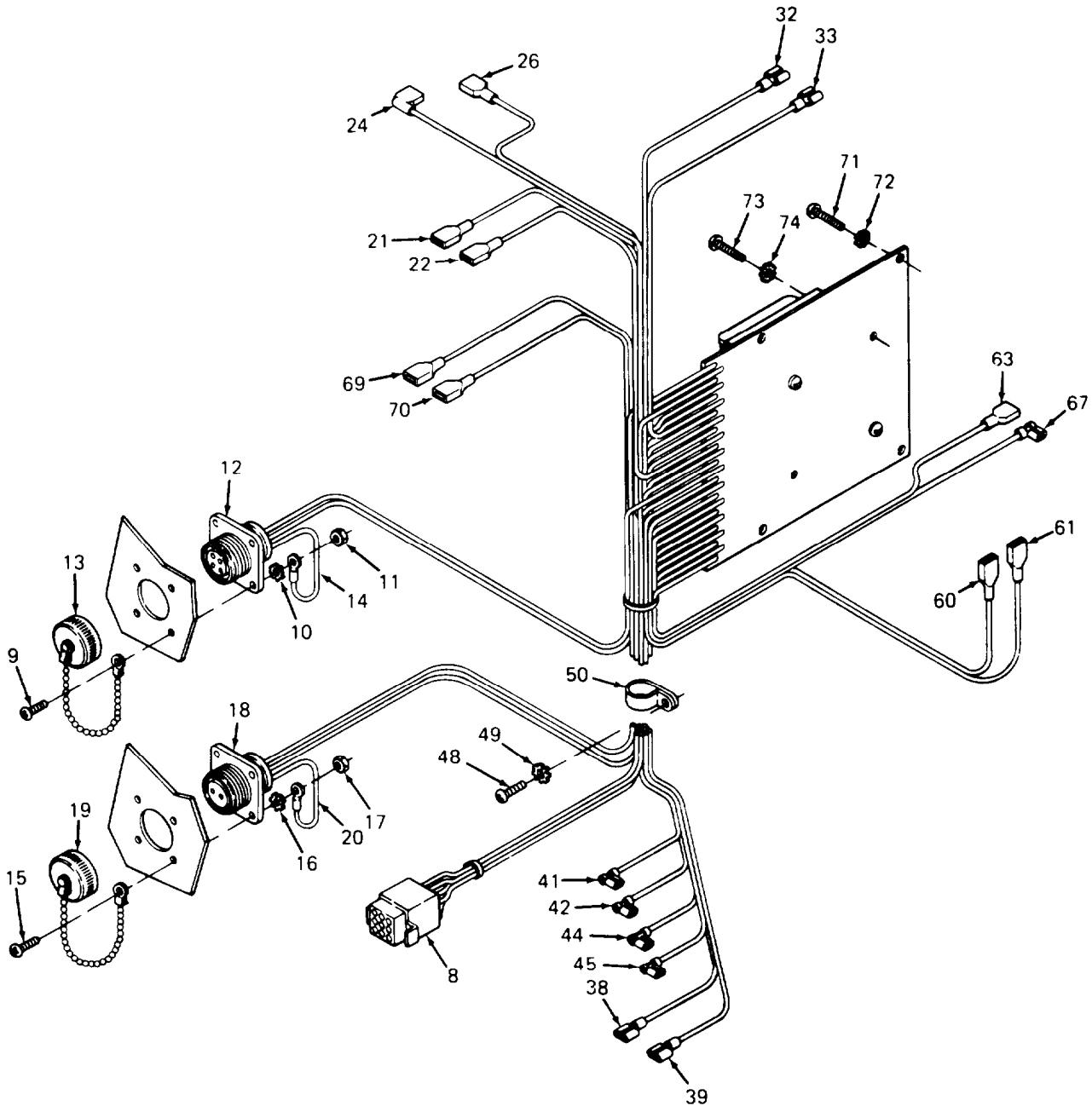

MODEL UH-68G

REMOVE/INSTALL PC BOARD ASSEMBLY (CONT)

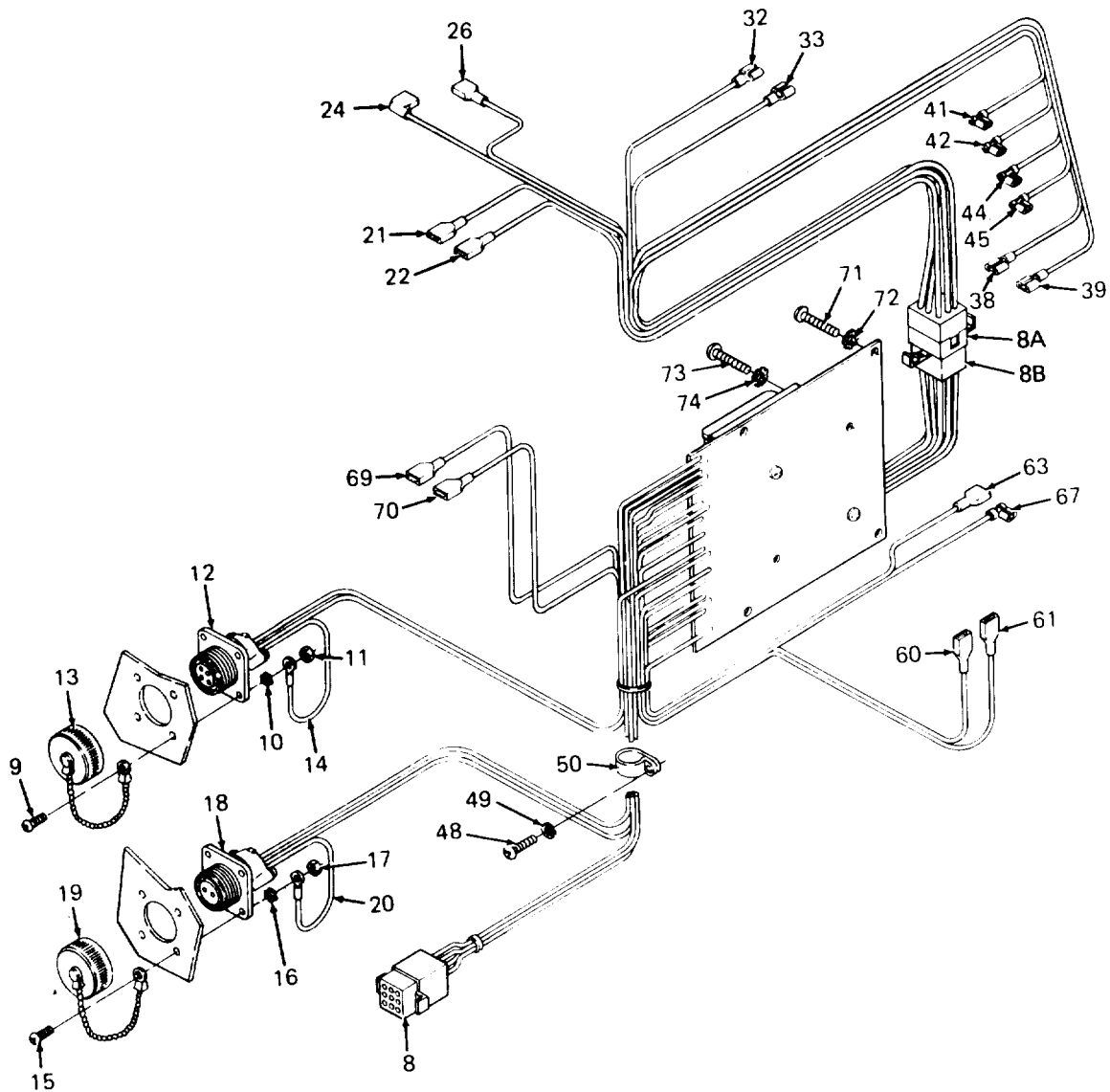

MODEL UH-68C31

REMOVE/INSTALL PC BOARD ASSEMBLY (CONT)

6. Locate lower overheated thermostat bracket (28). Remove two screws (29) and lock washers (30), and lift out bracket and lower overheated thermostat (31).
7. Disconnect red/white and grey wires (32 and 33) from thermostat (31).
8. Pry out grommet (34) and pull wires (32 and 33) through hole in bracket (28).
9. Locate flame switch and bracket assembly (35). Remove two screws (36) and lock washers (37). Pull flame switch and bracket assembly (35) out of opening in heater bulkhead.
10. Disconnect yellow and grey wires (38 and 39) from upper overheated thermostat (40).
11. Disconnect red and violet wires (41 and 42) from flame switch (43). Disconnect red and brown wires (44 and 45) from flame switch (46).
12. Pry out grommet (47) and pull wires through opening in flame switch and bracket assembly.

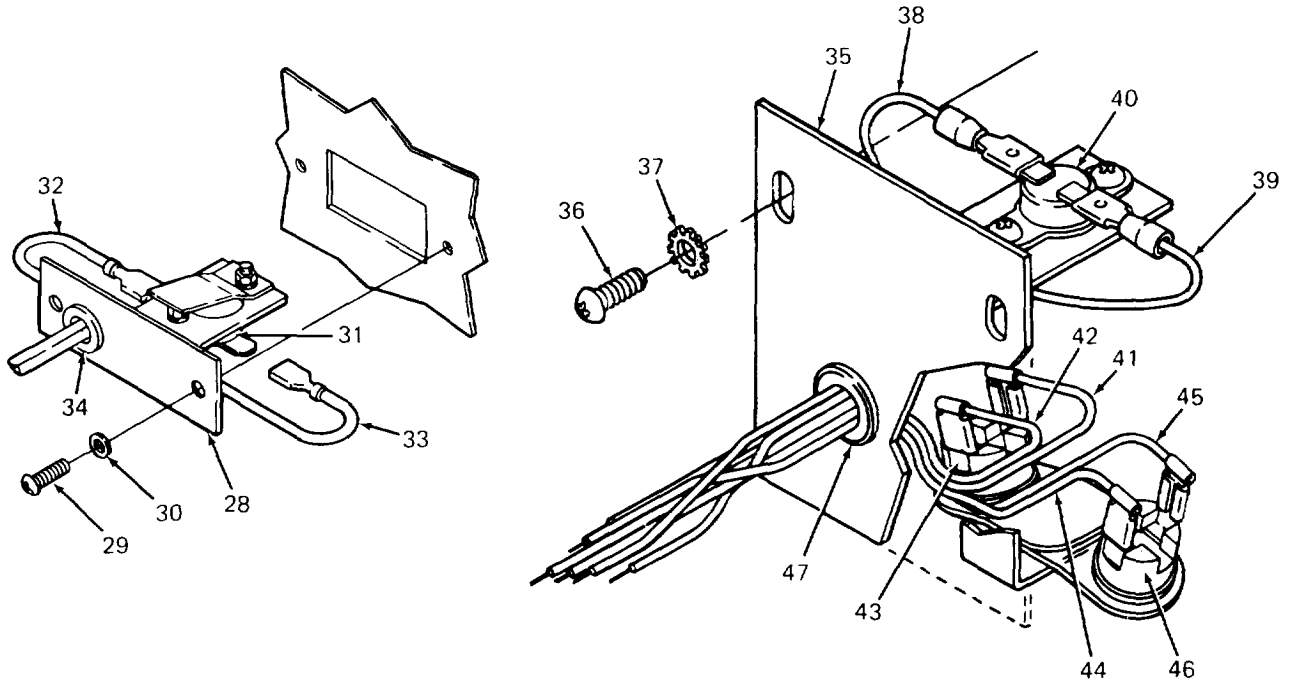

13. Remove screw (48) and lock washer (49) and release wiring from clamp (50).

REMOVE/INSTALL PC BOARD ASSEMBLY (CONT)

WARNING

Death or serious injury could occur if precautions are not taken when maintaining this equipment. Position HEATER-OFF-FAN switch to OFF and remove power cable plug from POWER RECEPTACLE. Remove electrical charge from ventilating motor capacitor C3 by shorting out contacts using tool having insulated handle. Always disconnect power cable before making continuity tests or before repairing heater. Always have another person standing by who is trained in electric shock first aid.

14. Remove six screws (51) and lock washers (52). Lift off bottom cover (53).
15. Reach through heater case opening (54) and disconnect louver linkage from right-hand louver panel (55) and left-hand louver panel (56). Remove each panel by unlocking eight studs (57).

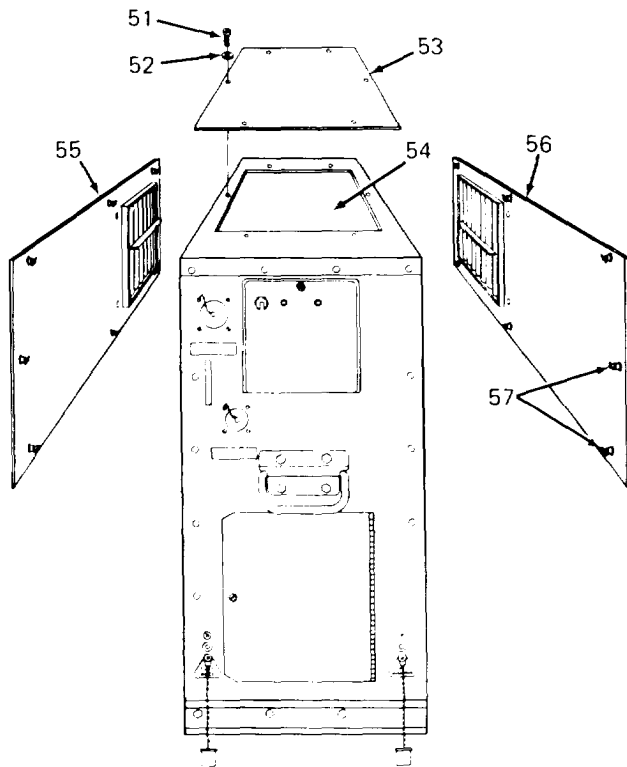

16. Pry out grommet (58) and carefully pull wires (21, 22, 24, 26, 32, 33, 38, 39, 41, 42, 44, and 45) up through hole in exchanger housing panel.

REMOVE/INSTALL PC BOARD ASSEMBLY (CONT)

17. Locate wires of PC board connected to the transformer assembly and ventilating air motor on the right-hand side of heater. Cut cable ties (59) and discard.
18. Disconnect yellow wire (60) and white wire (61) from transformer (62).
19. Disconnect red wire (63) from ventilating air motor (64). Pull boot (65) away from capacitor (66) and disconnect white wire (67) from capacitor.

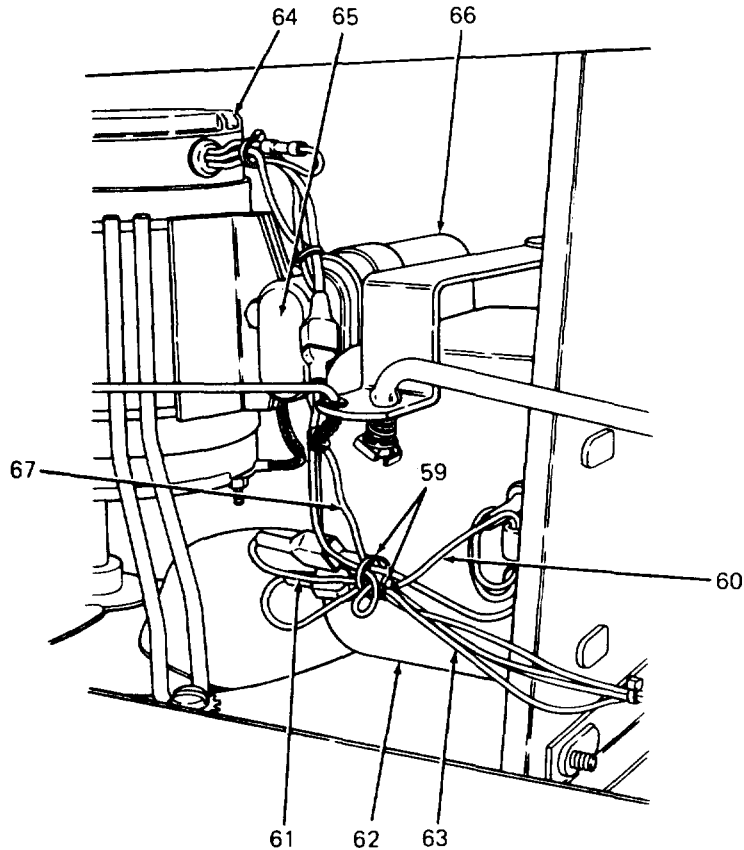

20. Locate combustion blower (68) on the left-hand side of heater. Disconnect yellow wire (69) and white wire (70) from combustion blower.
21. Locate PC board on right-hand side of heater. Remove two screws (71) and lock washers (72), and four screws (73) and lock washers (74). Lift out PC board assembly.

REMOVE/INSTALL PC BOARD ASSEMBLY (CONT)

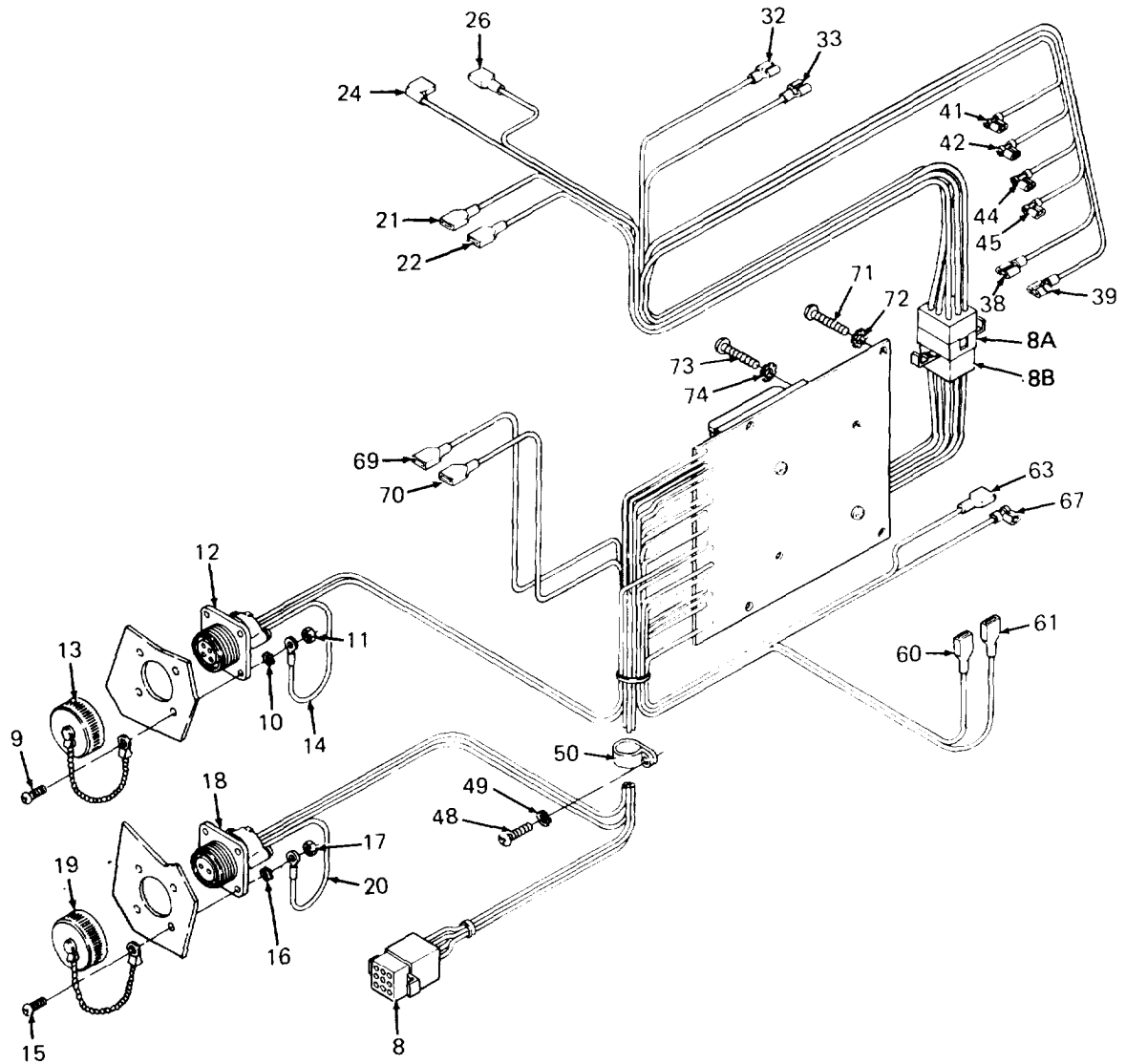

MODEL UH-68G1

REMOVE/INSTALL PC BOARD ASSEMBLY (CONT)**INSTALLATION:**

1. Install PC board using four screws (73) and lock washers (74) and two screws (71) and lock washers (72).
2. Thread wires (21, 22,24,26,32, and 33) down through hole in exchanger housing panel. For Model UH-68G, thread wires (38, 39,41,42,44, and 45) down through hole in exchanger housing panel. Press grommet (58) into place.

CAUTION

When connecting wires, always connect like colored wires to each other, e.g., connect red wire to red wire, white wire to white wire.

3. Locate combustion blower (68) on the left-hand side of heater. Connect yellow wire (69) and white wire (70) to wires of combustion blower.
4. Connect red wire (63) to red wire of ventilating air motor (64). Connect white wire (67) to capacitor (66). Place boot (65) over terminal of capacitor.
5. Connect yellow wire (60) and white wire (61) to wires of transformer (62).
6. Install new tie wraps (59) as shown.

NOTE

Steps 7 through 14 apply for Model UH-68G only.

7. Thread wires (36, 39,41,42,44, and 45) through opening in flame switch and bracket assembly. Press grommet (47) into opening.
8. Connect red and violet wires (41 and 42) to flame switch (43). Connect red and brown wires (44 and 45) to flame switch (46).
9. Connect yellow and grey wires (38 and 39) to upper overhear thermostat (40).
10. Install flame switch and bracket assembly (35) in opening in heater bulkhead. Attach assembly to bulkhead using two screws (36) and lock washers (37). With screws loosened, adjust flame switch and bracket assembly downward as far as it will go. This seats flame switches (43 and 46) against the heat exchanger. Tighten screws (36).
11. Thread red/white and grey wires (32 and 33) through hole in bracket (28). Press grommet (34) into hole,
12. Connect red/white and grey wires (32 and 33) to lower overhear thermostat (31).
13. Install thermostat (31) through mounting hole in heater bulkhead and secure thermostat mounting bracket (28) using two screws (29) and lock washers (30).
14. Connect green and blue wires (21 and 22) to fuel solenoid (23). Connect orange wire (24) to carburetor thermostat (25). Connect white wire (26) to carburetor heater (27).

REMOVE/INSTALL PC BOARD ASSEMBLY (CONT)

15. On Model UH-68G1, connect PC board assembly harness plug (8A) to receptacle (8 B).

NOTE

For Model UH-68G, PC board assembly may have been replaced with PC board assembly and wiring harness for Model UH-68G1.

16. Install POWER RECEPTACLE (18) inside heater case using four screws (15), lock washers (16), and nuts (17). Use one screw (15), lock washer (16), and nut (17) to attach dust cap and chain(19) and ground wire (20).
17. Install EXTERNAL FUEL PUMP RECEPTACLE (12) inside heater case using four screws (9), lock washers (10), and nuts (11). Use one screw (9), lock washer (10), and nut(11) to attach dust cap and chain (13) and ground wire (14).
18. Install PC board wiring receptacle (8) inside heater case. Push receptacle through mounting hole until locking tabs snap into place.
19. Connect control box harness plug (7) to receptacle (8).
20. Install clamp (50) on bundled wires projecting down through grommet (58). Secure clamp to heater bulkhead using screw (48) and lock washer (49) .
21. Close control box cover (1), front access door (2), and right side door (3). Lock studs (4, 5, and 6).
22. Install right-hand louver panel (55) and left-hand louver panel (56), Secure by locking eight studs (57) at each panel.
23. Reach through heater case opening (54) and connect louver linkage to louver panels (55 and 56).
24. Install bottom cover (53) using six screws (51) and lock washers (52).

REPAIR PC BOARD ASSEMBLY WIRING RECEPTACLE

TOOLS: Tool kit, service, refrigeration unit
NSN 5180-00-596-1474

MATERIALS/PARTS: Sealant (Item 10, Appendix E)
Tape (Item 14, Appendix E)
Receptacle
Terminal, male (9)
Tie, cable (as required)

GENERAL SAFETY INSTRUCTIONS:

Power off.
Heater cool.

REPAIR:**WARNING**

Death or serious injury could occur if precautions are not taken when maintaining this equipment. Position HEATER-OFF-FAN switch to OFF, remove power cable plug from POWER RECEPTACLE, and ground capacitors C1 and C2 prior to gaining access to heater compartments. Terminals of capacitors are accessible at end cover of combustion blower. Always disconnect power cable before repairing heater. Always have another person standing by who is trained in electric shock first aid.

Allow sufficient time for heater to cool to room temperature before gaining access to heater compartments.

PC board assembly wires are potted into PC board wiring receptacle. Repair consists of replacing receptacle. PC board wires are long enough to allow cutting close to receptacle and installing new receptacle. Proceed as follows:

1. Open control box cover (1) by unlocking stud (2).
2. Remove six screws (3) and lock washers (4). Lift off bottom cover (5).
3. Reach through heater case opening (6) and disconnect louver linkage from right-hand louver panel (7). Remove panel by unlocking eight studs (8).
4. Disconnect control box harness (9) from PC board wiring receptacle (10). Depress locking tabs and pull receptacle out of mounting hole from inside heater case.

REPAIR PC BOARD ASSEMBLY WIRING RECEPTACLE (CONT)

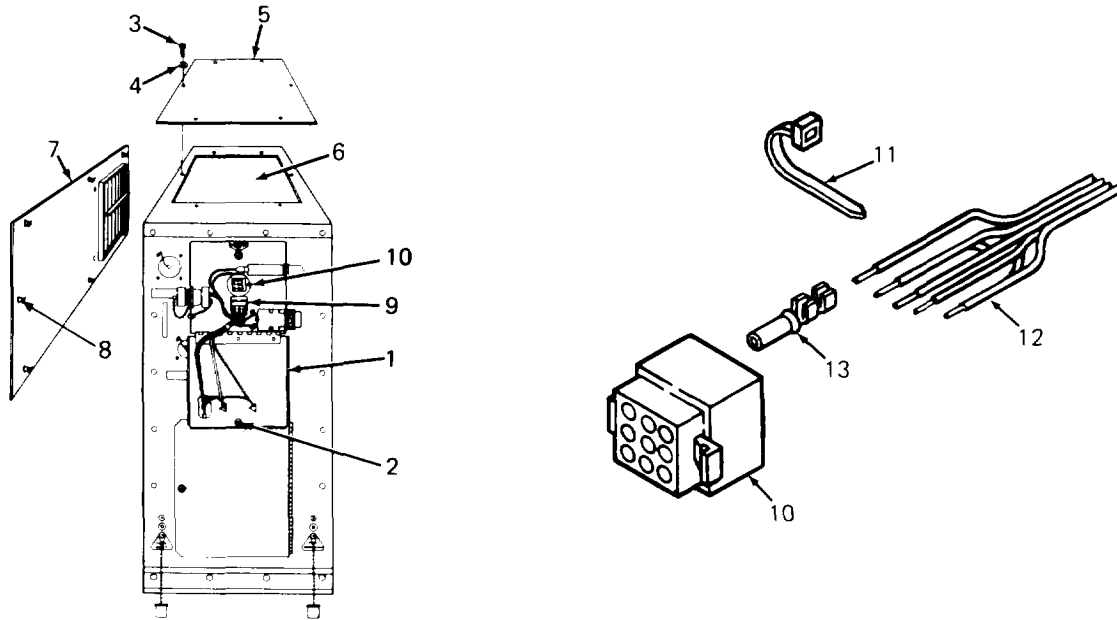

5. Pull receptacle (10) out of side of heater case. Cut off and discard cable ties (11) as needed to allow access to harness wires (12).
6. Tag wires (12) and cut as close to receptacle (10) as possible. Discard receptacle.
7. Strip 1/4 inch (6.35 mm) of insulation from end of each wire (12). Crimp male terminal (13) on each wire.
8. Refer to table 4-2 and push wire terminals (13) into numbered sockets in receptacle (10). Wire colors and socket numbers must be in accordance with the table.

Table 4-2. Receptacle Wiring Sequence

Wire Color	Socket No.
Black	1
Brown	2
Red	3
White	4
Yellow	5
Orange	6
Grey	7
Green	8
Not used	9

REPAIR PC BOARD ASSEMBLY WIRING RECEPTACLE (CONT)

9. Make potting rim (14) around receptacle (10) using tape. Rim must project beyond receptacle around wires (12) 1/4 inch (6.35 mm) or more.

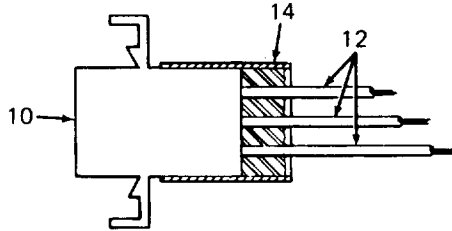

10. Fill rim with MI L-A-46106 sealant and allow 8 hours to harden.
11. Install cable ties (11) to replace any removed.
12. Install PC board wiring receptacle (20) from inside heater case. Push receptacle through mounting hole until locking tabs snap into place. Plug control box harness (9) into receptacle.
13. Install right-hand louver panel (7) by locking eight studs (8).
14. Reach through heater case opening (6) and connect louver linkage to right-hand louver panel (7).
15. Install bottom cover (5) using six screws (3) and lock washers (4).
16. Close control box cover (1) and lock stud (2).

REPAIR PC BOARD ASSEMBLY WIRING TERMINALS

TOOLS: Tool kit, service, refrigeration unit
NSN 5180-00-596-1474

EQUIPMENT CONDITION:

<u>Page</u>	<u>Condition Description</u>
3-107	Safety thermostats and flame switch and bracket assembly removed.

GENERAL SAFETY INSTRUCTIONS:

Power off.
Heater cool.

REPAIR:

WARNING

Death or serious injury could occur if precautions are not taken when maintaining this equipment. Position HEATER-OFF-FAN switch to OFF, remove power cable plug from POWER RECEPTACLE, and ground capacitors C1 and C2 prior to gaining access to heater compartments. Terminals of capacitors are accessible at end cover of combustion blower. Always have another person standing by who is trained in electric shock first aid.

Allow sufficient time for heater to cool to room temperature before gaining access to heater compartments.

1. Check ring tongue terminals (1) for security, damage, and burning. Replace loose or damaged terminal. If damaged terminal is still firmly crimped to wire, cut wire close to terminal. Strip 3/8 inch (9.53 mm) of insulation and crimp on new terminal,
2. Check quick disconnect terminals (2) for security, damage, and burning. Be sure terminal makes firm contact with mating terminal. Replace loose, damaged, or poorly fitting terminals. If damaged terminal is still firmly crimped to wire, cut wire close to terminal. Strip 3/8 inch (9.53 mm) of insulation and crimp on new terminal.
3. Check soldered wire ends (3) for weak or broken connections. Resolder where needed. Be sure 1/4 inch (6.35 mm) of good wire is stripped before soldering.

REPAIR PC BOARD ASSEMBLY WIRING TERMINALS (CONT)

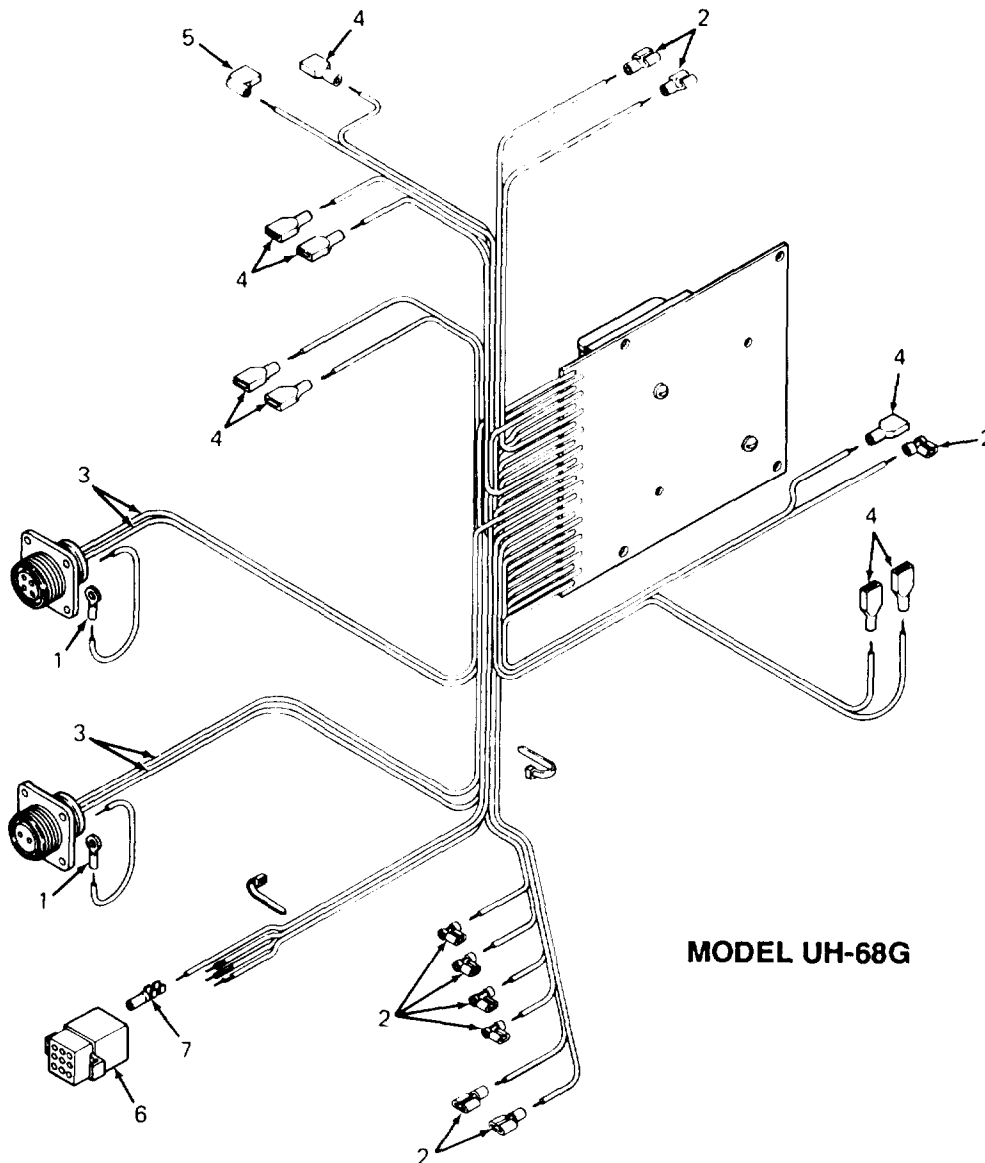

MODEL UH-68G

4. Check female couplers (4) and terminal flag (5) for security, damage, and burning. Be sure terminal makes firm contact with mating terminal. Replace loose, damaged, or poorly fitting terminals. If damaged terminal is still firmly crimped to wire, cut wire close to terminal. Strip 3/8 inch (9.53 mm) of insulation and crimp on new terminal.
5. Check receptacle (6) for loose wires. Check potting for security. Check receptacle sockets for signs of burning or other damage to male terminals (7). If receptacle is defective, refer to REPAIR PC BOARD ASSEMBLY WIRING RECEPTACLE, REPAIR, page 4-21, and replace.
6. For Model UH-68G1, check plug (8) for loose wires. Check potting for security. Check plug sockets for signs of burning or other damage to female terminals (9). If plug is defective, refer to REPAIR PC BOARD ASSEMBLY HARNESS RECEPTACLE AND PLUG, page 4-26.2, and replace.

REPAIR PC BOARD ASSEMBLY WIRING TERMINALS (CONT)

7. For Model UH-68G1, check receptacle (10) for loose wires. Check potting for security. Check receptacle sockets for signs of burning or other damage to male terminals (11). If receptacle is defective, refer to REPAIR PC BOARD ASSEMBLY HARNESS RECEPTACLE AND PLUG, page 4-26.1, and replace.

NOTE

For Model UH-68G, PC board assembly may have been replaced with PC board assembly and wiring harness for Model UH-68G1.

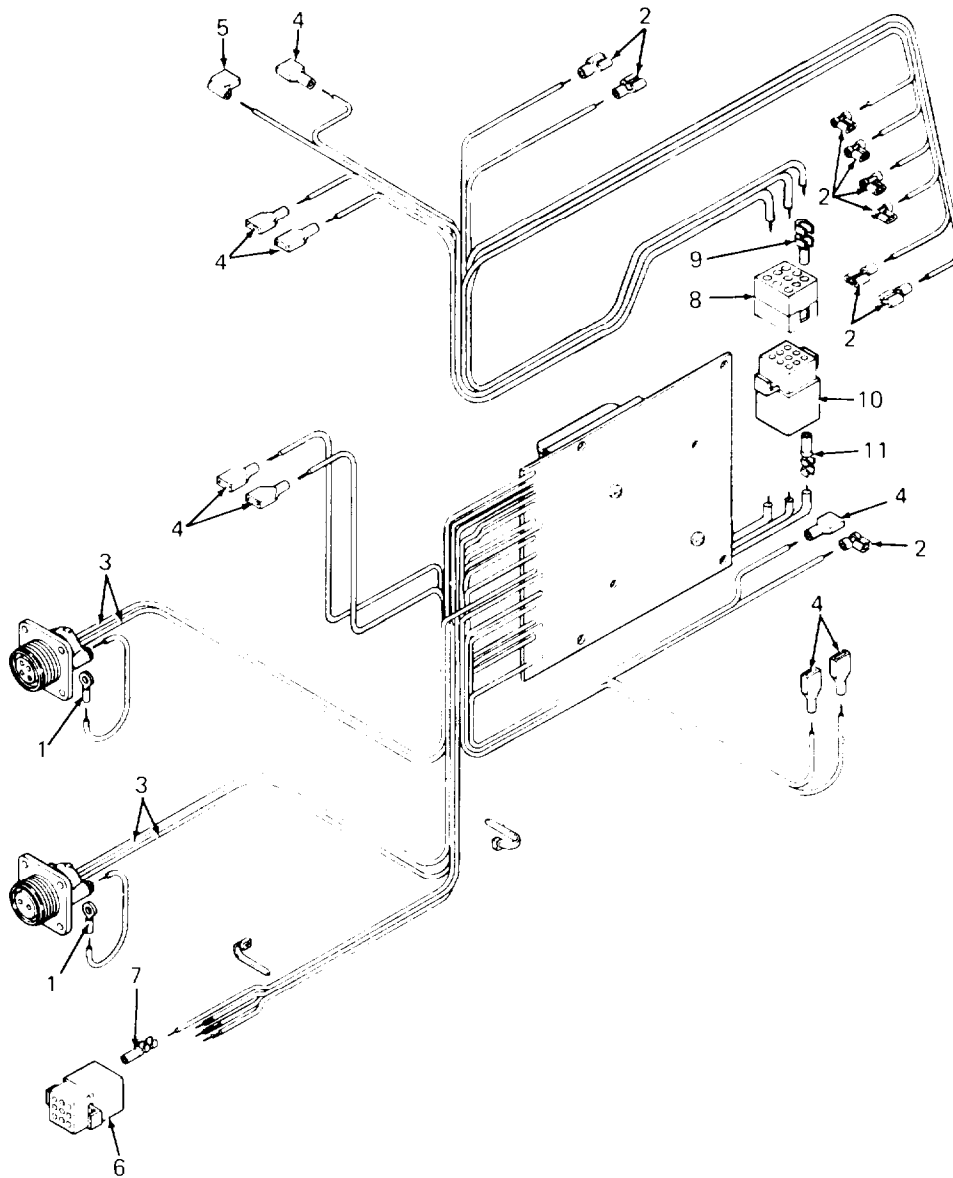

MODEL UH-68G1

REPAIR PC BOARD ASSEMBLY HARNESS RECEPTACLE AND PLUG

TOOLS: Tool kit, service, refrigeration unit
NSN 5180-00-596-1474

MATERIALS/PARTS: Sealant (Item 10, Appendix E)
Tape (Item 14, Appendix E)
Printed circuit board assembly harness plug
Printed circuit board assembly harness receptacle
Terminal, female (9)
Terminal, male (4)

GENERAL SAFETY INSTRUCTIONS:

Power off.
Heater cool.

REPAIR:**WARNING**

Death or serious injury could occur if precautions are not taken when maintaining this equipment. Position HEATER-OFF-FAN switch to OFF, remove power cable plug from POWER RECEPTACLE, and ground capacitors C1 and C2 prior to gaining access to heater compartments. Terminals of capacitors are accessible at end cover of combustion blower. Always have another person standing by who is trained in electric shock first aid.

Allow sufficient time for heater to cool to room temperature before gaining access to heater compartments.

PC board assembly harness wires are potted into PC board assembly harness receptacle and plug. Repair consists of replacing receptacle and plug. PC board assembly harness wires are long enough to allow cutting close to receptacle and plug and installing new receptacle and plug. Proceed as follows:

NOTE

For Model UH-68G, PC board assembly may have been replaced with PC board assembly and wiring harness for Model UH-8G1.

1. Repair receptacle as follows:
 - a. Pull receptacle (1) out of side of heater case.
 - b. Cut off and discard cable ties (2) as needed to allow access to harness wires (3).
 - c. Tag wires (3) and cut as close to receptacle (1) as possible. Discard receptacle.
 - d. Strip 1/4 inch (6.35 mm) of insulation from end of each wire (3). Crimp female terminal (4) on each wire.

REPAIR PC BOARD ASSEMBLY HARNESS RECEPTACLE AND PLUG (CONT)

- e. Refer to table 4-2.1 and push female terminals (4) into numbered sockets in receptacle (1). Wire colors and socket numbers must be in accordance with the table.

Table4-2.1 Harness Receptacle Wiring Sequence

Wire Color	Socket No.
Blue	1
White	2
Red	3
Violet	4
Yellow	5
Red/White	6
Orange	7
Green	8
Brown	9

- f. Install cable ties (2) to replace any removed.

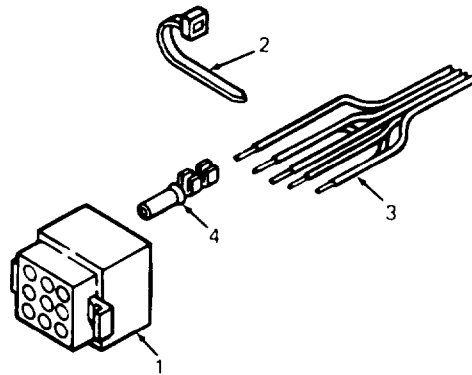

2. Repair plug as follows:

- a. Pull plug (6) out of side of heater case.
- b. Cut off and discard cable ties (7) as needed to allow access to harness wires (8).
- c. Tag wires (8) and cut as close to plug (6) as possible. Discard plug.
- d. Strip 1/4 inch (6.35 mm) of insulation from end of each wire (8). Crimp male terminal (9) on each wire.

REPAIR PC BOARD ASSEMBLY HARNESS RECEPTACLE AND PLUG (CONT)

- e. Refer to table 4-2.2 and push male terminals (9) into numbered sockets in plug (6). Wire colors and socket numbers must be in accordance with the table.

Table 4-2.2 Harness Plug Wiring Sequence

Wire Color	Socket No.
Blue	1
White	2
Red	3
Violet	4
Yellow	5
Red/White	6
Orange	7
Green	8
Brown	9

- f. Install cable ties (7) to replace any removed.

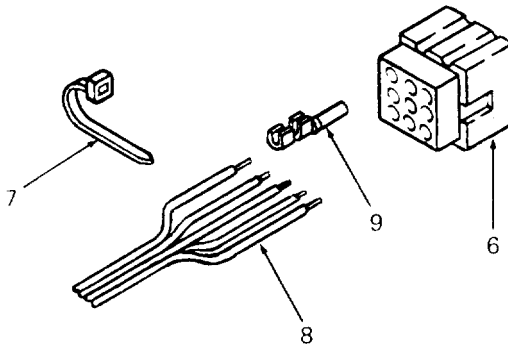

TEST PC BOARD ASSEMBLY

TEST EQUIPMENT: Volt ohmmeter

TOOLS: Tool kit, service, refrigeration unit
NSN 5180-00-596-1474

REFERENCES:

Page 3-107 Inspect/Reset/Remove/install Safety Thermostats and
Flame Switch and Bracket Assembly, Removal

GENERAL SAFETY INSTRUCTIONS:

Power off.
Heater cool.

PREPARATION FOR TESTING:

WARNING

Death or serious Injury could occur if precautions are not taken when maintaining this equipment. Position HEATER-OFF-FAN switch to OFF, remove power cable plug from POWER RECEPTACLE, and ground capacitors C1 and C2 prior to gaining access to heater compartments. Terminals of capacitors are accessible at end cover of combustion blower. Always have another person standing by who is trained in electric shock first aid.

Remove electrical charge from ventilating air motor capacitor C3 by shorting out contacts using tool having insulated handle.

Allow sufficient time for heater to cool to room temperature before gaining access to heater compartments.

1. Remove six screws(1) and lock washers (2). Lift off bottom cover (3).
2. Reach through heater case opening (4) and disconnect buyer linkage from louvers of right-hand louver panel (5) and left-hand louver panel (6).
3. Remove right-hand louver panel (5) and left-hand louver panel (6) by unlocking eight studs (7) at each panel.
4. Open right heater case door (8) by unlocking stud (9). Open front access door (10) by unlocking stud (11). Open control box cover (12) by unlocking stud (13).

TEST PC BOARD ASSEMBLY (CONT)

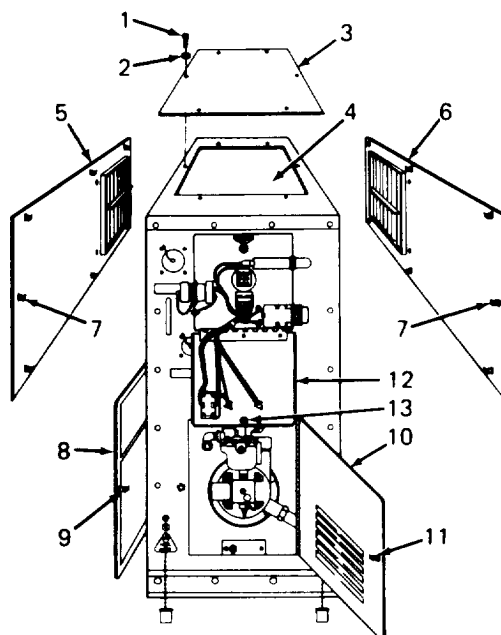

5. Before testing PC board assembly, follow troubleshooting and maintenance/testing procedures for component involved. Be sure fault is not in component or wiring to component.
6. Be sure control box harness is not faulty before testing circuits of control box components. Refer to INSPECT CONTROL BOX WIRING HARNESS, page 3-45.
7. Disconnect unsoldered wires before testing.

TESTING:

1. Tests for PC board assembly are contained in table 4-3. Table has six columns providing information necessary to perform each test, as follows:
 - a. Column (1) - Component Circuit. Identifies circuit to be tested.
 - b. Column (2) - Heater Mode. Describes condition of heater for testing named circuit.
 - c. Column (3) - Test For/Meter Setting. Describes proper setting of volt ohmmeter.
 - d. Columns (4 and 5) - Probe No. 1 and probe No. 2. Explains where each probe is placed. Probe numbers are arbitrary. Either probe may be placed at either position.
 - e. Column (6) - Meter Indication. What meter will show if circuit is good. Failure to achieve indication means circuit is faulty.
2. No repair to PC board is authorized. If testing indicates faulty circuit, replace PC board assembly.

TEST PC BOARD ASSEMBLY (CONT)

Table 4-3. PC Board Testing

(1) Component Circuit	(2) Heater Mode	(3) Test For/ Meter Setting	(4) Probe No. 1	(5) Probe No. 2	(6) Meter Indi- cation
CIRCUIT BREAKER	Power Cable: Plugged	Voltage	Black Wire (1)	Ground	110Vac
CIRCUIT BREAKER	Power Cable: Plugged	Voltage	Brown Wires (2, 3)	Ground	110Vac
RESET Circuit Breaker	Power Cable: Unplugged	Resistance R x 1	Violet Wires (4, 5)	Yellow Wires (6, 7)	Zero re- sistance
RESET Circuit Breaker	Power Cable: Unplugged	Resistance R x 1 0	Grey Wire (8)	Yellow Wires (6, 7)	650 Ohms
ROOM THERMO Receptacle	Power Cable: Plugged	Voltage	Orange Wire (9) Terminal A	Violet Wire (5) Terminal C	110Vac
HEATER-OFF-FAN Switch: OFF	Power Cable: Plugged	Voltage	Brown Wire (2)	Ground	110Vac
HEATER-OFF-FAN Switch: FAN	Power Cable: Plugged	Voltage	Red Wire (10)	Ground	110Vac
HEATER-OFF-FAN Switch: HEATER	Power Cable: Plugged	Voltage	Orange Wires (9,11,12)	Ground	110Vac
HEATER-OFF-FAN Switch: OFF	Power Cable: Plugged	Voltage	Red Wire (10)	Ground	Zero V ac
HEATER-OFF-FAN Switch: OFF	Power Cable: Plugged	Voltage	Orange Wires (9,11,12)	Ground	Zero V ac
HEAT Indicator Light (White)	Power Cable: Plugged	Voltage	Orange Wire (12)	White Wire (13)	110Vac
FAULT Indicator Light (Red)	Power Cable: Plugged HEATER-OFF- FAN Switch: HEATER Heater in FAULT mode. (To cause FAULT mode, disconnect fuel solenoid.)	Voltage	Violet Wire (4)	Yellow Wire (7)	110Vac

TEST PC BOARD ASSEMBLY (CONT)

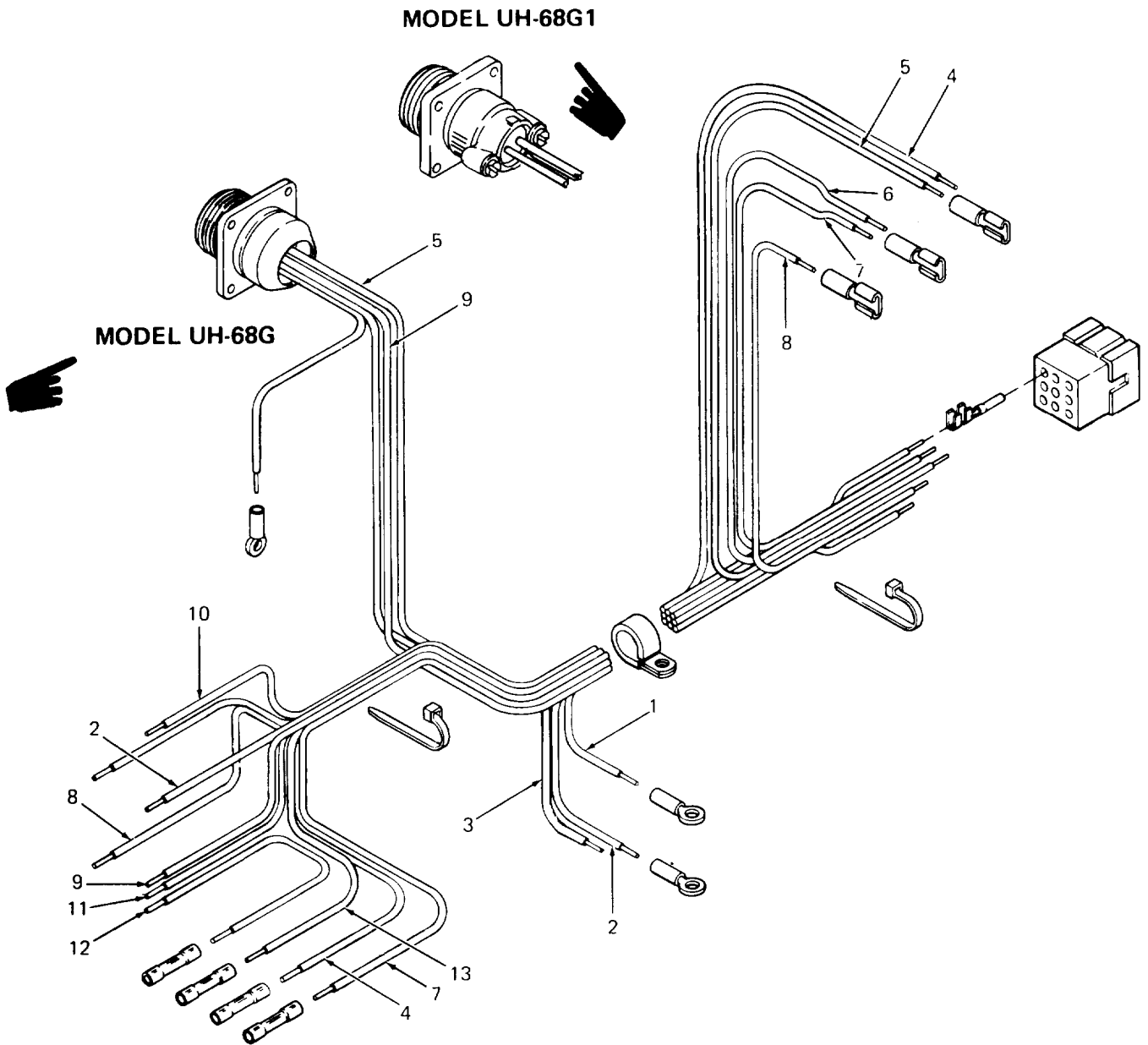

TEST PC BOARD ASSEMBLY (CONT)

Table 4-3. PC Board Testing – Continued

(1) Component Circuit	(2) Heater Mode	(3) Test For/ Meter Setting	(4) Probe NC. 1	(5) Probe No. 2	(6) Meter indi- cation
--------------------------	--------------------	--------------------------------------	-----------------------	-----------------------	---------------------------------

WARNING

Disconnect fuel solenoid before performing following tests to prevent fuel flow to burner and ignition. Set probes before turning HEATER-OFF-FAN switch to HEATER.

EXTERNAL FUEL PUMP RECEPTACLE	Power Cable: Plugged HEATER-OFF FAN Switch: HEATER	Voltage	Blue Wire (14) Terminal A	Green Wire (15) Terminal B	28 V dc
Carburetor Heater/Carburetor Thermostat	Power Cable: Plugged HEATER-OFF-FAN Switch: HEATER	Voltage	Orange Wire (16)	White Wire (17)	110 V ac

NOTE

Refer to **INSPECT/TEST/REMOVE/INSTALL SAFETY THERMOSTATS AND FLAME SWITCH AND BRACKET ASSEMBLY, REMOVAL**, page 3-105, to gain access to thermostat wires.

Flame Switch and Bracket Assembly	Power Cable: Plugged HEATER-OFF FAN Switch: HEATER	Voltage	Brown Wire (18)	Red Wire (19)	110 V ac
Flame Switch and Bracket Assembly	Power Cable: Plugged HEATER-OFF FAN Switch: HEATER	Voltage	Violet Wire (20)	Red Wire (21)	Zero Reading
Upper Thermostat (Fan Side)	Power Cable: Plugged HEATER-OFF FAN Switch: HEATER	Voltage	Yellow Wire (22)	Any White Wire or Terminal Connector	110 V ac

TEST PC BOARD ASSEMBLY (CONT)

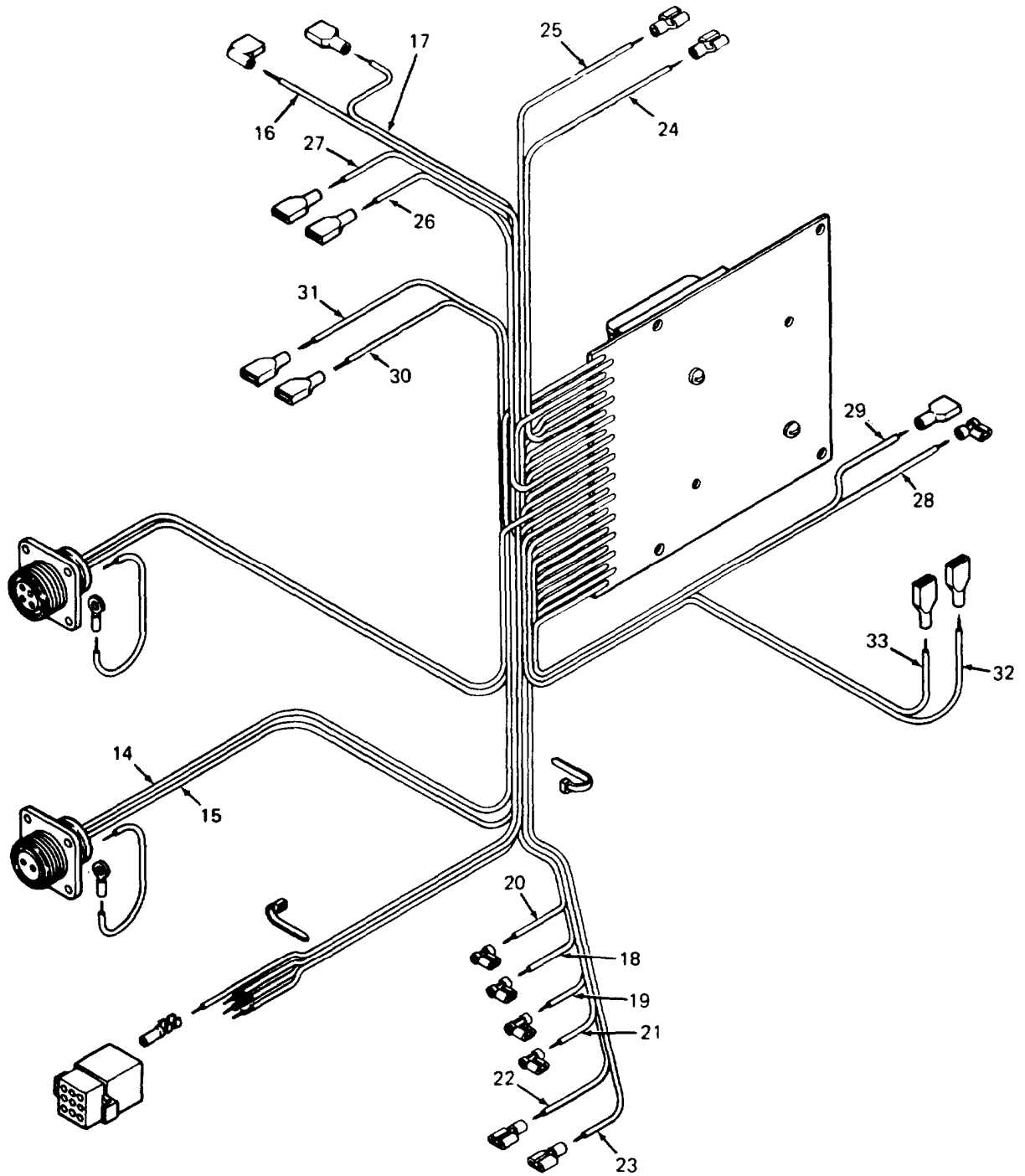

MODEL UH-68G

TEST PC BOARD ASSEMBLY (CONT)

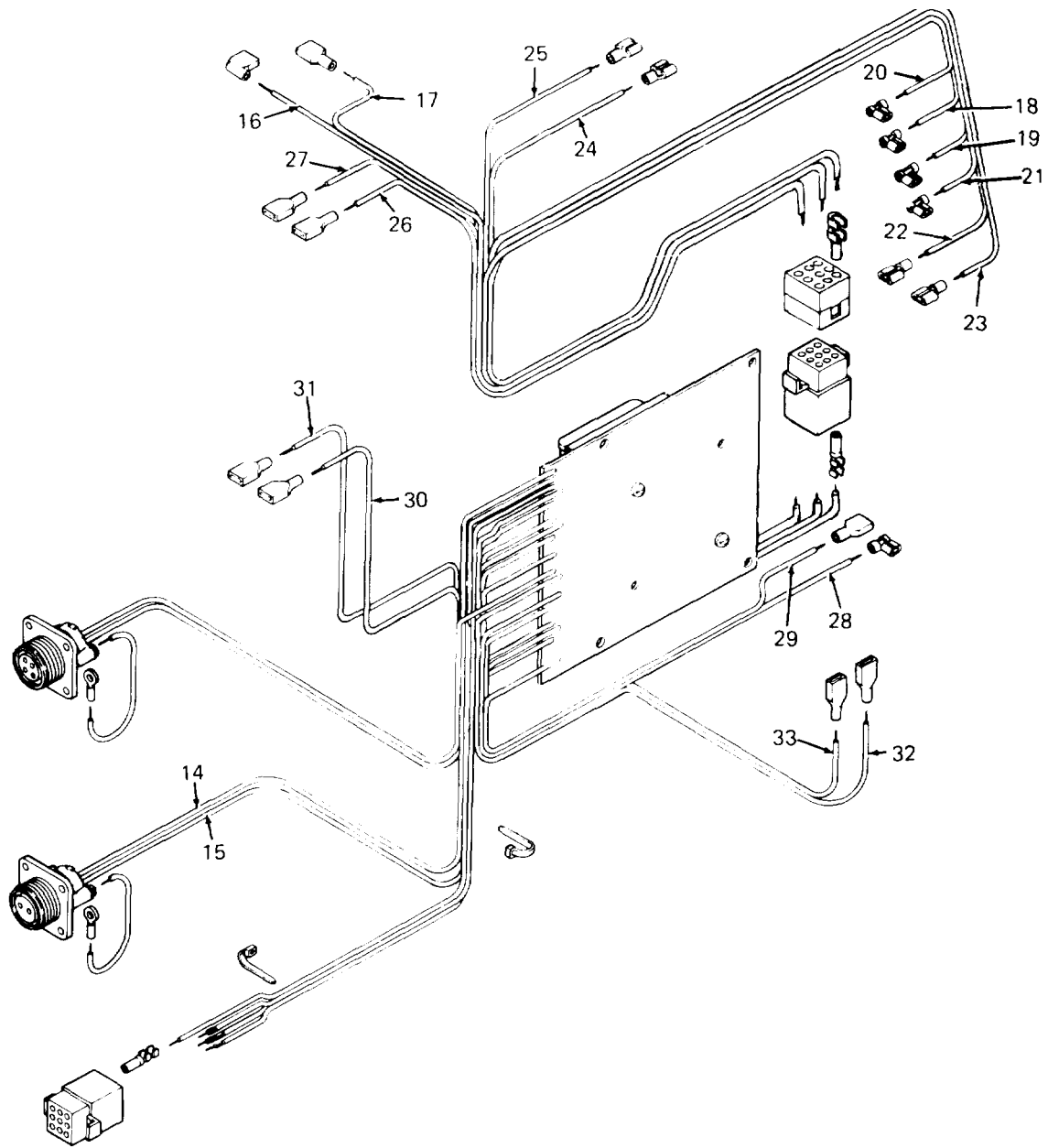

MODEL UH-68G1

TEST PC BOARD ASSEMBLY (CONT)

Table 4-3. PC Board Testing – Continued

(1) Component Circuit	(2) Heater Mode	(3) Test For/ Meter Setting	(4) Probe No. 1	(5) Probe No.2	(6) Meter Indi- cation
Upper Thermostat (Fan Side)	Power Cable: Plugged HEATER-OFF- FAN Switch: HEATER	Voltage	Grey Wire (23)	Any White Wire or Terminal Connector	110 V ac
Lower Thermostat (Discharge Side)	Power Cable: Plugged HEATER-OFF- FAN Switch: HEATER	Voltage	Grey Wire (24)	Any White Wire or Terminal Connector	110 V ac
Lower Thermostat (Discharge Side)	Power Cable: Plugged HEATER-OFF- FAN Switch: HEATER	Voltage	Red/White Wire (25)	Any White Wire or Terminal Connector	110 V ac
Fuel Solenoid	Power Cable: Plugged HEATER-OFF FAN Switch: HEATER	Voltage	Blue Wire (26)	Green Wire (27)	28 V dc
Ventilating Air Motor	Power Cable: Plugged HEATER-OFF- FAN Switch: HEATER	Voltage	White Wire (From PC Board) (28)	Red Wire (29)	110 V ac
Combustion Blower	Power Cable: Plugged HEATER-OFF- FAN Switch: HEATER	Voltage	White Wire (30)	Yellow Wire (31)	110 V ac
Transformer	Power Cable: Plugged HEATER-OFF- FAN Switch: HEATER	Voltage	White Wire (32)	Yellow Wire (33)	110 V ac

HEATER CASE ASSEMBLY REPAIR PROCEDURES INDEX

PROCEDURE	PAGE
Disassemble/Assemble Heater Case Assembly	4-33
General Repair Heater Case Assembly	4-35
Remove/Install Shields and Shield Insulator	4-37
Repair Painted Surfaces	4-39

DISASSEMBLE/ASSEMBLE HEATER CASE ASSEMBLY

TOOLS: Tool kit, service, refrigeration unit
NSN 5180-00-596-1474

EQUIPMENT CONDITION:

Page	<u>Condition Description</u>
3-38	Control box assembly removed.
4-12	Printed circuit (PC) board assembly removed.
3-78	Doors removed.
3-87	Fuel lines and fittings removed.
3-91	Fuel filter removed.
4-40	Combustion blower removed.
4-53	Ventilating air motor removed.
3-107	Safety thermostats and thermocouple removed.
4-62	Burner head assembly removed.
3-110	Ignition transformer and cable removed.
4-67	Heat exchanger removed.

DISASSEMBLY:

1. Force grommet (1) out of hole in exchanger housing panel. If grommet is cracked, worn, or damaged, replace.
2. Remove one screw (2) and two lock washers (3) and lift off ground strap (4). If ground strap is torn, badly corroded, or has loose terminal, replace.
3. Remove three screws (5) and lock washers (6) at front of heater and lift off front mounting bracket (7).
4. Remove four screws (8) and lock washers (9) at rear of heater and lift off rear mounting bracket (10).

DISASSEMBLE/ASSEMBLE HEATER CASE ASSEMBLY (CONT)

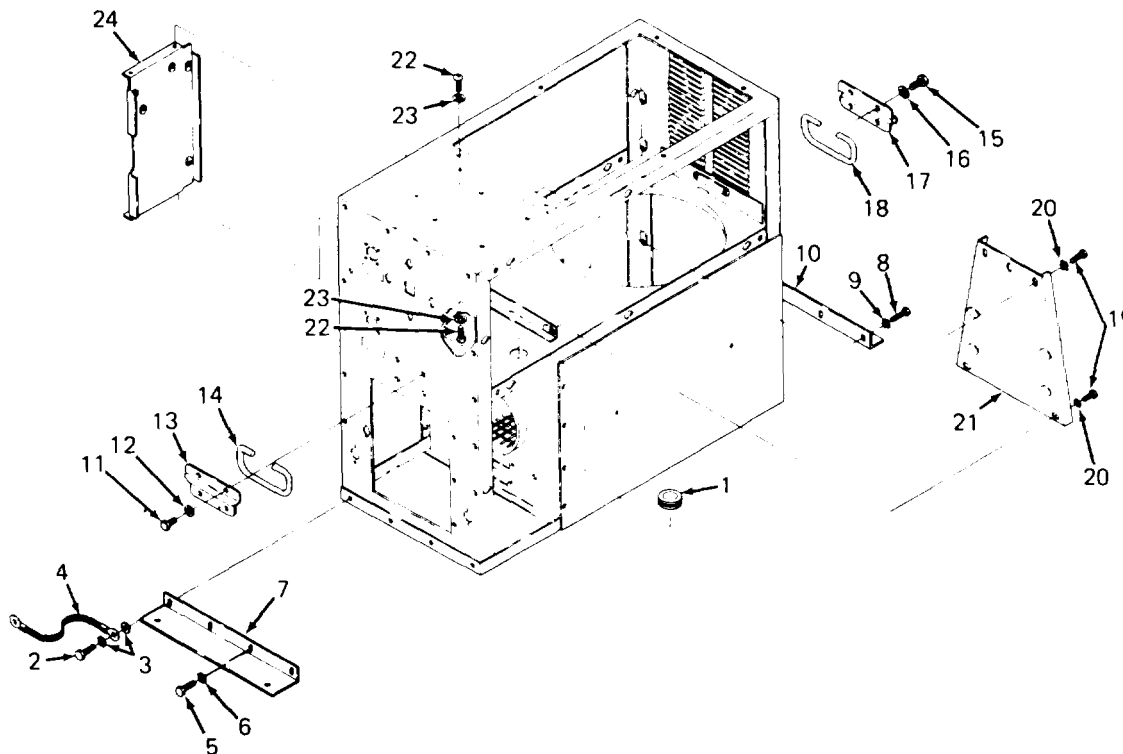

5. Remove four screws (11) and lock washers (12) and lift off front handle plate (13) and handle (14). Remove four screws (15) and lock washers (16) and lift off rear handle plate (17) and handle (18).
6. Remove five screws (19) and lock washers (20) and lift out bulkhead (21).
7. Remove four screws (22) and lock washers (23) and lift out PC board mounting plate (24).

ASSEMBLY:

1. Install PC board mounting plate (24) using four screws (22) and lock washers (23).
2. Install bulkhead (21) using five screws (19) and lock washers (20).
3. Install rear handle (18) and handle plate (17) using four screws (15) and lock washers (16). Install front handle (14) and handle plate (13) using four screws (11) and lock washers (12). Mount handle plates with widest dimension toward top of heater to protect hands when carrying heater.
4. Install rear mounting bracket (10) using four screws (8) and lock washers (9).
5. Install front mounting bracket (7) using three screws (5) and lock washers (6).
6. Install ground strap (4) and complete installation of front mounting bracket (7) using one screw (2) and two lock washers (3).
7. Install grommet (1) in hole in exchanger housing panel.

GENERAL REPAIR HEATER CASE ASSEMBLY

TOOLS: Tool kit, service, refrigeration unit
NSN 5180-00-596-1474

MATERIALS/PARTS: Dry cleaning solvent (Item 13, Appendix E)

EQUIPMENT CONDITION:

Page	<u>Condition Description</u>
3-38	Control box assembly removed.
4-12	Printed circuit (PC) board assembly removed.
3-78	Doors removed.
3-87	Fuel lines and fittings removed.
3-91	Fuel filter removed.
4-40	Combustion blower removed.
4-53	Ventilating air motor removed.
3-107	Safety thermostats and thermocouple removed.
4-62	Burner head assembly removed.
3-110	Ignition transformer and cable removed.
4-67	Heat exchanger removed.

REPAIR:

1. Replace damaged and missing stud receptacles (1). Receptacles can be removed and installed manually without use of tools.
2. Replace damaged and missing hardware.
3. Check identification plate (2) for security, If blind rivets are loose, drill out from outside heater case and install new rivets.

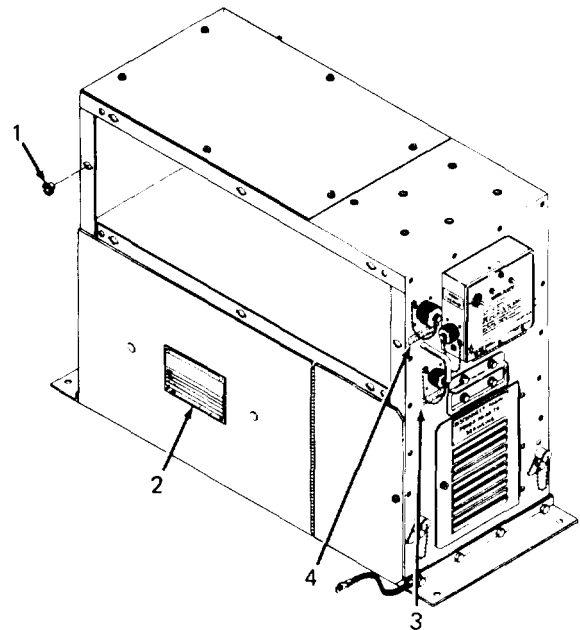
**NOTE**

Identification plate (2) is normally never completely removed. If removed, same identification plate must be installed.

4. Check EXTERNAL FUEL PUMP RECEPTACLE label (3) and POWER RECEPTACLE label (4) for legibility and security. If unreadable, replace.

GENERAL REPAIR HEATER CASE ASSEMBLY (CONT)

5. If label has partially peeled, press back in place. Replace labels which will not stick firmly to surface. Proceed as follows:
 - a. Peel off defective label.

WARNING

Dry cleaning solvent P-D-680 (safety or Stoddard's Solvent) is potentially dangerous. Avoid repeated and prolonged breathing of vapors and skin contact with the liquid. Do not use near open flame, arcing equipment, or other ignition sources. Always wear eye protection and protective clothing. Flash point of P-D-680 is 100° to 138° F (38° to 59° C).

- b. Use rag dampened with P-D-680 dry cleaning solvent to clean off old adhesive, dirt, and grease or oil. Allow surface to air dry.
- c. Carefully apply appropriate pressure sensitive label.
- d. Straighten bends and hammer out dents which interfere with mounting or operation of heater or its components. Replace removable parts of heater case assembly if badly damaged or distorted.
- e. Be sure grounding strap is fastened securely to one of mounting brackets.

REMOVE/INSTALL SHIELDS AND SHIELD INSULATOR

TOOLS: Tool kit, service, refrigeration unit
NSN 5180-00-596-1474

MATERIALS/PARTS: Rivet, Pop (11)

EQUIPMENT CONDITION:

Page	<u>Condition Description</u>
3-38	Control box assembly removed.
4-12	Printed circuit (PC) board assembly removed.
3-78	Doors removed.
3-87	Fuel lines and fittings removed.
3-91	Fuel filter removed.
4-40	Combustion blower removed.
4-53	Ventilating air motor removed.
3-107	Safety thermostats and thermocouple removed.
4-62	Burner head assembly removed.
3-110	Ignition transformer and cable removed.
4-67	Heat exchanger removed.

REMOVAL:

1. To remove two heater case shields (1) from heater case side panels (2), drill out two rivets (3) at each shield. Lift out two shield retainers (4) with each shield.
2. To remove rear cover shield (5), drill out four rivets (6). Lift off two support straps (7) with shield.
3. To remove shield insulator (8) from exchanger housing shield (9) of the heater case assembly, remove three rivets (10), one screw (11), and lock washer (12). Lift out two support straps (13 and 14) with shield insulator.

INSTALLATION:**NOTE**

Install shields (1 and 5) and shield insulator (8) with foil side facing inwardly toward heat exchanger.

1. Install shield insulator (8) on inside of exchanger housing shield (9) using two support straps (13 and 14), three rivets (10), one screw (11), and lock washer (12).

REMOVE/INSTALL SHIELDS AND SHIELD INSULATOR (CONT)

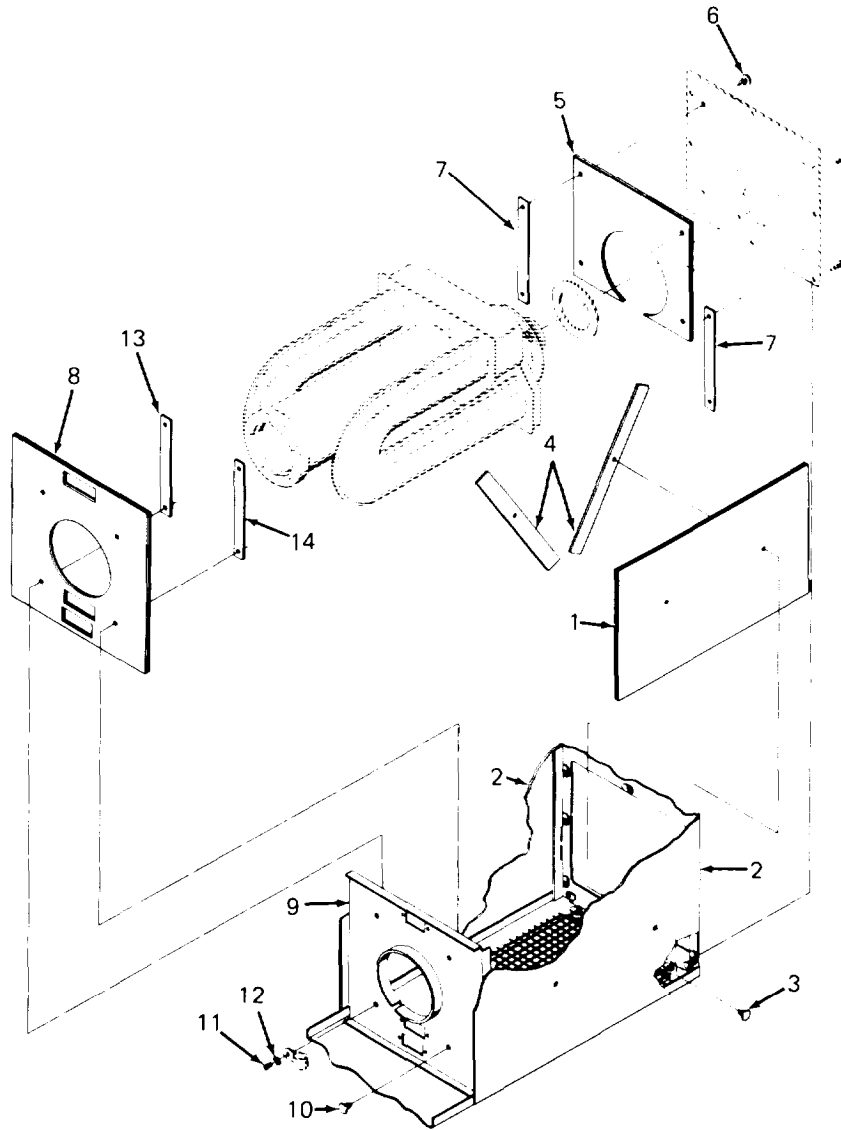

2. Install rear cover shield (5) using two support straps (7) and four rivets (6).
3. Install heater case shields (1) to inside of heater case side panels (2). Use two shield retainers (4) and two rivets (3) at each shield.

REPAIR PAINTED SURFACES

TOOLS: Tool kit, service, refrigeration unit
NSN 5180-00-596-1474

MATERIALS/PARTS: Enamel, alkyd, camouflage (Item 3, Appendix E)

REFERENCES:

TT-P-636 Primer Coating, Alkyd, Wood and Ferrous Metal

EQUIPMENT CONDITION:

Page	<u>Condition Description</u>
3-38	Control box assembly removed.
4-12	Printed circuit (PC) board assembly removed.
3-78	Doors removed.
3-87	Fuel lines and fittings removed.
3-91	Fuel filter removed.
4-40	Combustion blower removed.
4-53	Ventilating air motor removed.
3-107	Safety thermostats and thermocouple removed.
4-62	Burner head assembly removed.
3-110	Ignition transformer and cable removed.
4-67	Heat exchanger removed.

REPAIR:

1. Provide the following conditions for painting:
 - a. Be sure all surfaces are free of soil, impurities or corrosion, such as grease, oil, solder flux, welding flux, sand, rust scale, or other foreign matter.
 - b. Clean rusted areas to bare metal using sandpaper, wire brush, steel wool, or other abrasive material, Wipe clean. Surface must be dry.
 - c. Provide dry, well-ventilated, dust free area.
 - d. Ambient temperature shall be not less than 50° F (10° C). Relative humidity shall not be over 65 percent.
 - e. Paint and surface shall be approximately same temperature.
 - f. All painting equipment shall be free of moisture just prior to painting.
 - g. All materials shall be thoroughly mixed, There shall be no separation of materials during painting operations.
2. After surface preparation has been completed, apply primer coating in accordance with TT-P-636 as promptly as possible, and in any case within 24 hours.
3. Allow primer coating to dry thoroughly before applying topcoat.
4. Apply topcoat in accordance with MI L-E-52798 by spraying, dipping, or brushing.

ELECTRICAL PROCEDURES INDEX

PROCEDURE	PAGE
Remove/Install Combustion Blower and Housing	4-40
Remove/Install/Test Thermal Motor Protector	4-44
Remove/Install/Test Capacitors	4-46
Disassemble/Assemble/Test Blower Motor	4-47
Repair Blower Motor	4-51
Remove/Install Ventilating Air Motor	4-53
Test Ventilating Air Motor	4-58
Test Ventilating Air Motor Capacitor	4-60

REMOVE/INSTALL COMBUSTION BLOWER AND HOUSING

TOOLS: Tool kit, service, refrigeration unit
 NSN 5180-00-596-1474

Solder gun kit
 NSN 3439-00-930-1638

MATERIALS/PARTS: Solder (Item 12, Appendix E)

GENERAL SAFETY INSTRUCTIONS:

Power off.
 Heater cool.

REMOVAL:

WARNING

Death or serious injury could occur if precautions are not taken when maintaining this equipment. Position HEATER-OFF-FAN switch to OFF, remove power cable plug from POWER RECEPTACLE, and ground capacitors C1 and C2 prior to gaining access to heater compartments. Terminals of capacitors are accessible at end cover of combustion blower. Always disconnect power cable before making continuity tests or before repairing heater. Always have another person standing by who is trained in electric shock first aid.

Allow sufficient time for heater to cool to room temperature before gaining access to heater compartments.

1. Remove six screws (1) and lock washers (2) and lift off bottom cover (3).

REMOVE/INSTALL COMBUSTION BLOWER AND HOUSING (CONT)

2. Reach through heater case opening (4) and disconnect louver linkage from louvers of left-hand louver panel (5).
3. Remove left-hand louver panel (5) by unlocking eight studs (6). Open left heater case door by unlocking stud (7).

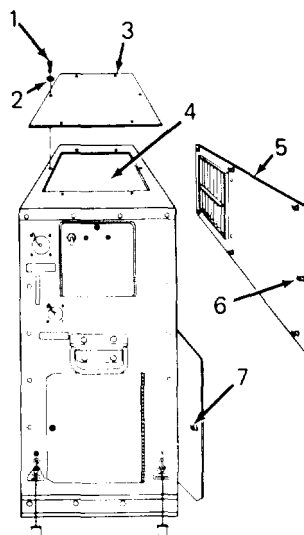

4. Remove screw (8) and lock washer (9). Lift out support tube (10).
5. Loosen hose clamp (11) and pull off blower air duct (12).
6. Disconnect yellow wire (13) and white wire (14) from yellow and white wires of printed circuit (PC) board assembly.
7. Remove four screws with lock washers (15) and lift out combustion blower and housing assembly (16).
8. Remove four screws (17) and lock washers (18) and Pulll blower housing cover (19) away from blower housing (20). Unsolder wires (21 and 22) from terminals of capacitors (23).
9. Remove four screws (24) and lock washers (25). Pull blower motor (26) and blower support (27) out of blower housing (20).
10. Remove four screws (28) and lock washers (29) and separate blower motor (26) from blower support (27).

REMOVE/INSTALL COMBUSTION BLOWER AND HOUSING (CONT)

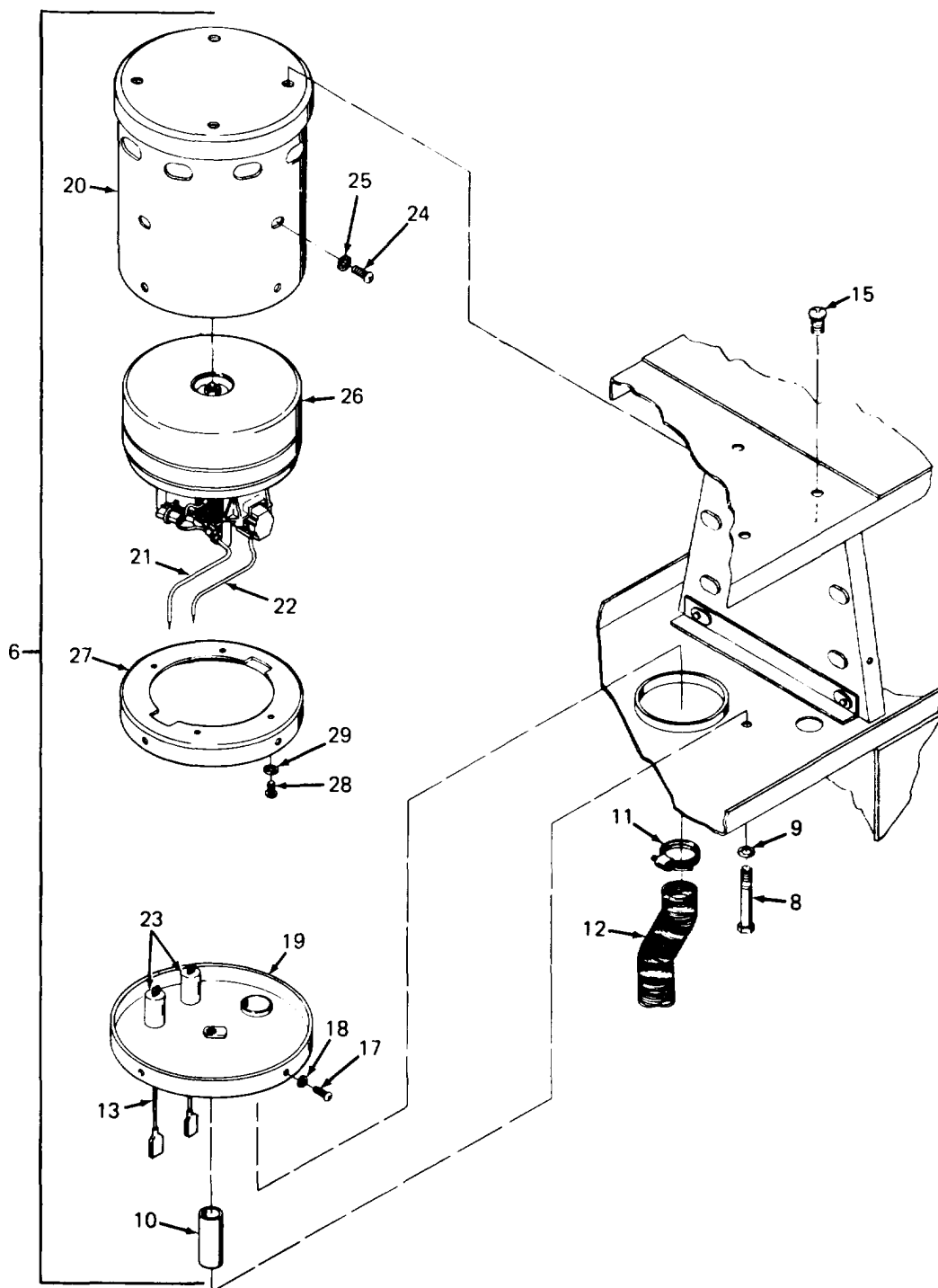

REMOVE/INSTALL COMBUSTION BLOWER AND HOUSING (CONT)

INSTALLATION:

1. Install blower motor (26) on blower support (27) using four screws (28) and lock washers (29).
2. Insert blower motor (26) and blower support (27) into blower housing (20). Secure with four screws (24) and lock washers (25).
3. Solder wires (21 and 22) to terminals of capacitors (23). Install cover (19) on housing (20) using four screws (17) and lock washers (18).
4. Install combustion blower and housing assembly (16) in heater case using four screws with lock washers (15).
5. Connect yellow wire (13) and white wire (14) to yellow and white wires of PC board assembly.
6. Install upper end of air duct (12) and secure with hose clamp (11).
7. Install support tube (10) and secure with screw (8) and lock washer (9).
8. Install left-hand louver panel (5) and lock eight studs (6). Close left heater case door and lock stud (7).
9. Reach through heater case opening (4) and connect louver linkage to louvers of left-hand louver panel (5).
10. Install bottom cover (3) using six screws (1) and lock washers (2).

REMOVE/INSTALL/TEST THERMAL MOTOR PROTECTOR

TEST EQUIPMENT: Volt ohmmeter

TOOLS: Tool kit, service, refrigeration unit
NSN 5180-00-596-1474

MATERIALS/PARTS: Sealant (Item 10, Appendix E)
Butt connector (2)
Cable tie (2)

EQUIPMENT CONDITION:

Page	Condition Description
4-40	Combustion blower and housing removed.

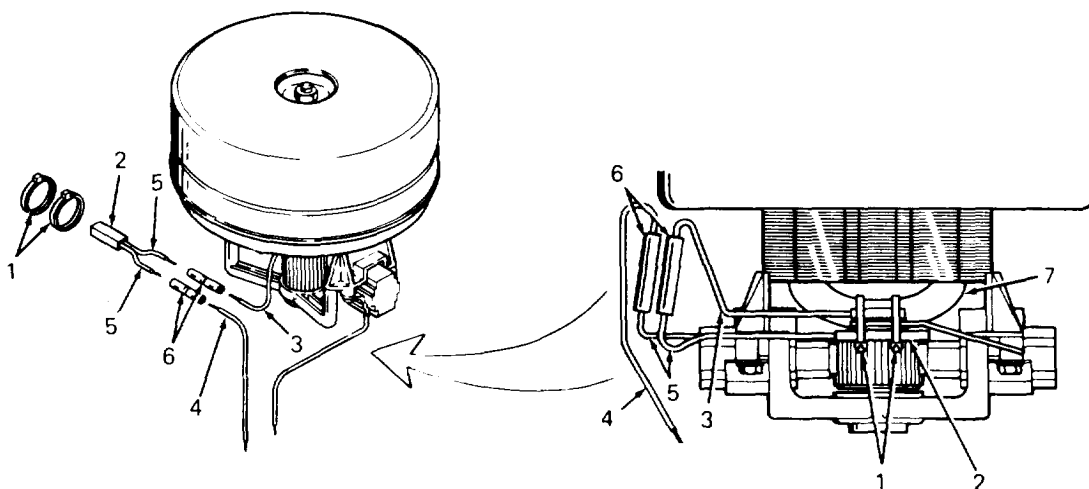

REMOVAL:

CAUTION

Be careful to avoid damage to the field coil when cutting away silicone seal and cable ties.

1. Carefully slice off silicone seal and cut two cable ties (1) holding thermal motor protector (2).
2. Disconnect wires (3 and 4) from motor protector leads (5) by removing butt connectors (6). Discard butt connectors.

REMOVE/INSTALL/TEST THERMAL MOTOR PROTECTOR (CONT)

INSTALLATION:

1. Connect leads (5) of motor protector (2) to wires (3 and 4) using new butt connectors (6).
2. Attach motor protector (2) to field coil (7) using two new cable ties (1).
3. Completely encase motor protector (2) and cable ties (1) with MIL-A-46106 sealant. Allow sealant eight hours to harden.

TESTING:

1. Disconnect thermal motor protector leads (5). Test at room temperature using volt ohmmeter.
2. With probes contacting motor protector leads (5), meter should read zero resistance. If meter indicates resistance, replace motor protector (2).

REMOVE/INSTALL/TEST CAPACITORS

TEST EQUIPMENT: Volt ohmmeter

TOOLS: Tool kit, service, refrigeration unit
NSN 5180-00-596-1474

Solder gun kit
NSN 3439-00-930-1638

MATERIALS/PARTS: Solder (Item 12, Appendix E)

EQUIPMENT CONDITION:

<u>Page</u>	<u>Condition Description</u>
4-40	Combustion blower and housing removed.

REMOVAL:

1. Unsolder yellow wire (1) and white wire (2) from terminals of capacitors (3).
2. Remove nut (4) and lock washer (5) from each capacitor (3). Lift out capacitors.

INSTALLATION:

1. Install each capacitor (3) in mounting hole (6) with threaded terminal projecting outside cover (7). Secure each capacitor using nut (4) and lock washer (5).
2. Solder yellow wire (1) and white wire (2) to terminals of capacitors (3) as shown.

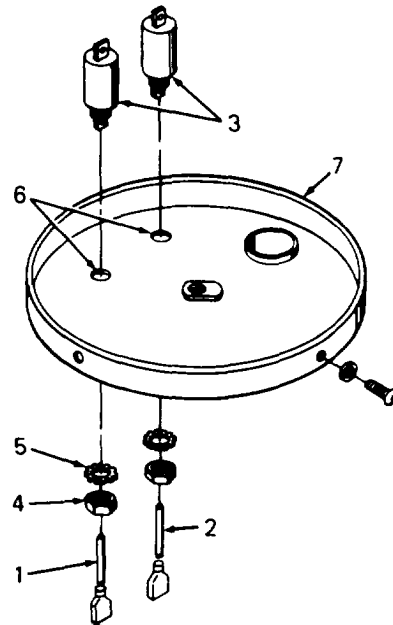

TESTING:

For test purposes, it is not necessary to unsolder wires (1 and 2) and remove capacitors from cover (7). Test as follows:

1. Use volt ohmmeter and test each capacitor for continuity by placing one probe in the wire connector and the other probe against the opposite end terminal of the capacitor. If capacitor has been removed, place probes on the end terminals of capacitor. Meter should read zero resistance. If meter reading is infinity, replace capacitor.
2. Using volt ohmmeter, place one probe against capacitor body and other probe against capacitor end terminal. Test each capacitor separately. Meter should read infinity. If meter does not show infinite resistance, replace capacitor.

DISASSEMBLE/ASSEMBLE/TEST BLOWER MOTOR

TEST EQUIPMENT:

- Rubber hose, 1/4-inch ID, 36-inch length
- Needle, inflating, football
- Jar or glass, tall (at least 16-inch water capacity)

TOOLS: Tool kit, service, refrigeration unit
 NSN 5180-00-596-1474

MATERIALS/PARTS: Dry cleaning solvent (Item 13, Appendix E)

REFERENCES:

- Page 4-40 Remove/Install Combustion Blower and Housing
- Page 4-51 Repair Blower Motor

EQUIPMENT CONDITION:

<u>Page</u>	<u>Condition Description</u>
4-40	Combustion blower and housing removed.

DISASSEMBLY:

1. Remove one screw (1) at each of two brush assemblies (2).
2. Move brush assemblies (2) to one side and remove two field screws (3). Remove frame cap (4) and pry out loading spring (5).
3. Remove nut (6) and flat washer (7). Pull out armature (8) and field (9). Do not remove ball bearings (10 and 11) from armature shaft except to replace.

NOTE

Do not disassemble items 12 thru 18 unless there is reason to believe the fan assembly is defective.

4. Pry off skeleton housing (12). Separate spacer (13), fan assembly (14), spacer spool (15), upper chamber (16), fan assembly (17), and lower chamber (18).

DISASSEMBLE/ASSEMBLE/TEST BLOWER MOTOR (CONT)

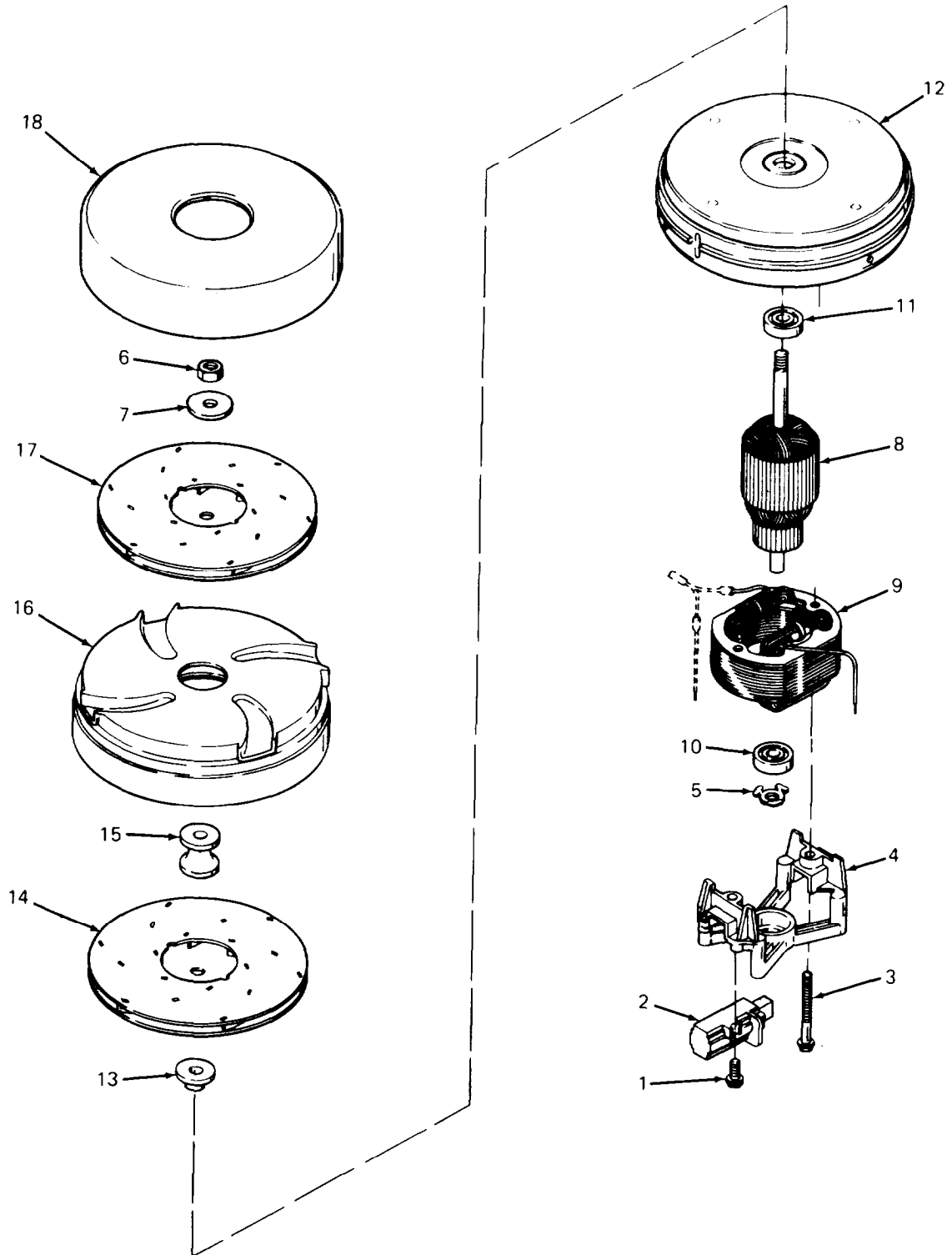

DISASSEMBLE/ASSEMBLE/TEST BLOWER MOTOR (CONT)**ASSEMBLY:**

1. Assemble following parts in order given:
 - a. lower chamber (18)
 - b. fan assembly (17)
 - c. upper chamber (16)
 - d. spacer spool (15)
 - e. fan assembly (14)
 - f. spacer (13)
2. Press skeleton housing (12) in place on parts assembled in step 1.
3. Install armature (8).
4. Hold armature and install flat washer (7) and nut (6). Torque nut to 40.00 in. lb (4.52 N•m).
5. Install loading spring (5).
6. Install field (9) and frame cap (4) using two field screws (3).
7. Install two brush assemblies (2) using screws (1).

TESTING:

1. Assemble 36-inch length of 1 /4-inch ID rubber hose, football inflating needle, and jar or glass containing at least 16 inches of water. Insert needle into one end of rubber hose.

WARNING

Death or serious injury could occur if precautions are not taken when maintaining this equipment. Position HEATER-OFF-FAN switch to OFF, remove power cable plug from POWER RECEPTACLE, and ground capacitors C1 and C2 at end cover of combustion blower. Always have another person standing by who is trained in electric shock first aid.

Allow sufficient time for heater to cool to room temperature before gaining access to heater compartments.

2. Open front access door (1) by unlocking stud (2).

DISASSEMBLE/ASSEMBLE/TEST BLOWER MOTOR (CONT)

WARNING

Be sure fuel to burner head is shut off during this test.

3. Disconnect fuel pump plug at EXTERNAL FUEL PUMP. RECEPTACLE (3).
4. Disconnect fuel solenoid (4).
5. Connect power cable to POWER RECEPTACLE (5).
6. Push inflating needle into combustion blower air duct (6) between blower and burner head assembly (7).
7. Turn HEATER-OFF-FAN switch to HEATER. Allow blower to attain full speed.
8. Put end of hose in water. Push hose deeper under surface until bubbling just stops. Measure length of hose that is submerged, This length must be at least 15 inches. If length is less than 15 inches, repair or replace blower motor. Refer to REMOVE/INSTALL COMBUSTION BLOWER AND HOUSING, page 4-40, and REPAIR BLOWER MOTOR, following this task.

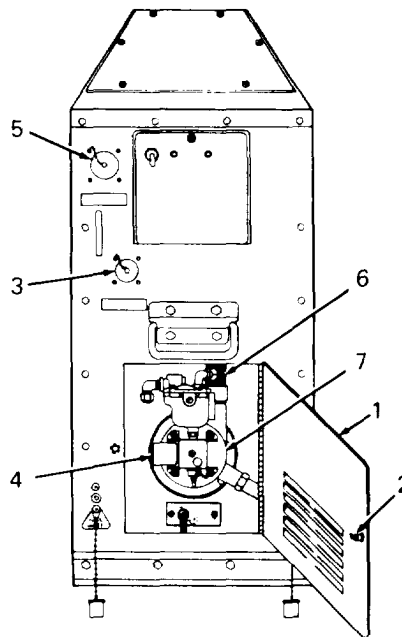

REPAIR BLOWER MOTOR

TOOLS: Tool kit, service, refrigeration unit
NSN 5180-00-596-1474

Puller, bearing

MATERIALS/PARTS:

Dry cleaning solvent (Item 13, Appendix E)
Sandpaper (Item 9, Appendix E)

EQUIPMENT CONDITION:

<u>Page</u>	<u>Condition Description</u>
4-47	Blower motor disassembled.

REPAIR:

Repair of the blower motor consists of cleaning electrical and nonelectrical parts and replacing defective parts. Proceed as follows:

WARNING

Dry cleaning solvent P-D-680 (safety or Stoddard's Solvent) is potentially dangerous. Avoid repeated and prolonged breathing of vapors and skin contact with the liquid. Do not use near open flame, arcing equipment, or other ignition sources. Always wear eye protection and protective clothing. Flash point of P-D-680 is 100° to 138° F (38° to 59°C).

1. Wipe electrical parts with cloth dampened with P-D-680 dry cleaning solvent. Allow to dry.
2. Immerse nonelectrical parts in P-D-680 dry cleaning solvent. Wipe thoroughly and allow to dry.

NOTE

Brushes are designed to last minimum of 200 hours of operation.

3. Check brushes for cracks, chips, wear, or scoring. If brushes are worn or otherwise damaged, replace brush assemblies (1).

REPAIR BLOWER MOTOR (CONT)

4. Check commutator (2). Replace armature (3) and bearings (4 and 5) if commutator is scored or badly burned. If commutator is lightly scored or dirty, clean with fine sandpaper.
5. Slowly rotate bearings (4 and 5) by hand. If roughness is noted in either bearing, pull both bearings and press on new bearings.
6. Check fan assemblies (6 and 7) for bent or damaged parts. Replace defective fan assemblies.

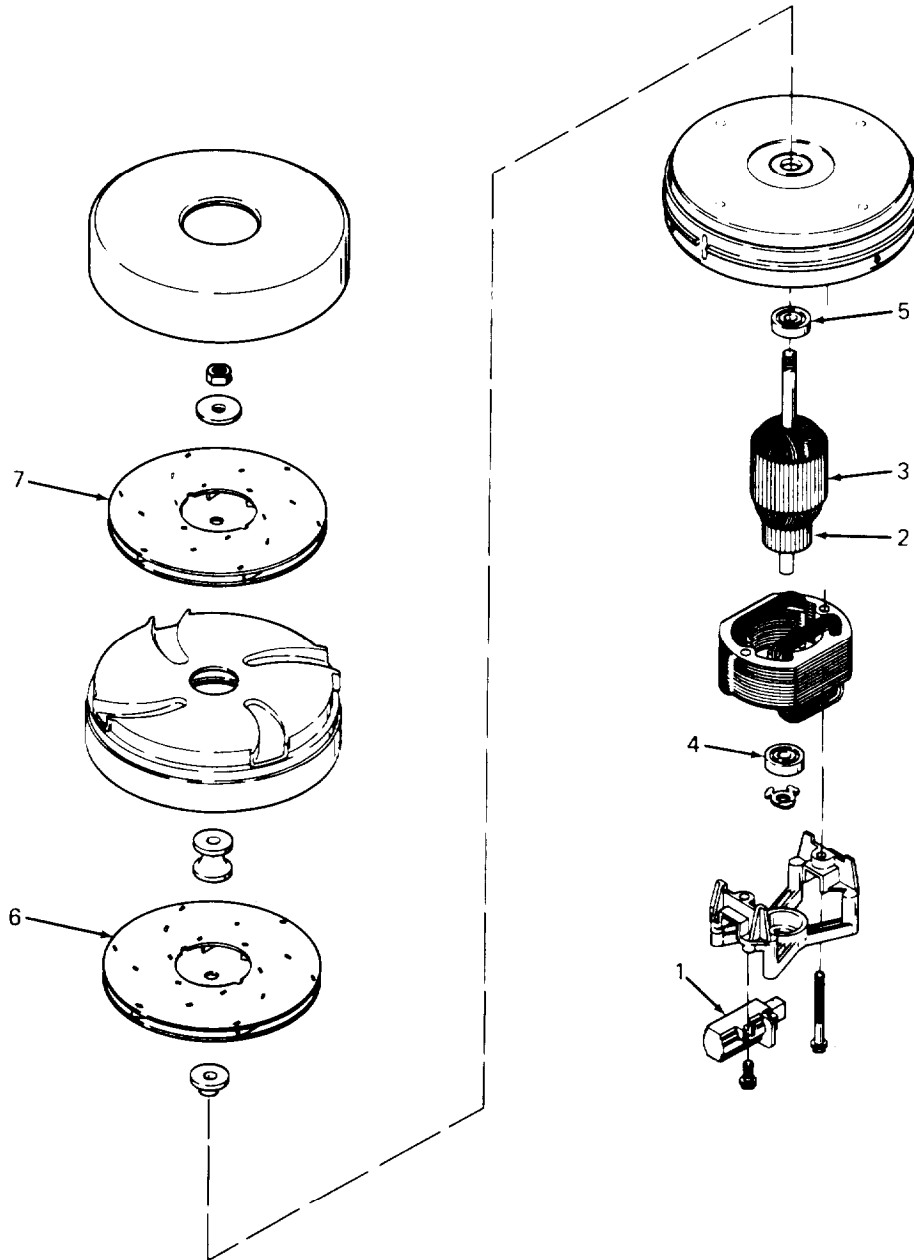

REMOVE/INSTALL VENTILATING AIR MOTOR

TOOLS: Tool kit, service, refrigeration unit
NSN 5180-00-596-1474

GENERAL SAFETY INSTRUCTIONS:

Power off.
Heater cool.

REMOVAL:**WARNING**

Death or serious injury could occur if precautions are not taken when maintaining this equipment. Position HEATER-OFF-FAN switch to OFF, remove power cable plug from POWER RECEPTACLE, and ground capacitors C1 and C2 prior to gaining access to heater compartments. Terminals of capacitors are accessible at end cover of combustion blower. Always have another person standing by who is trained in electric shock first aid.

Allow sufficient time for heater to cool to room temperature before gaining access to heater compartments.

1. Remove six screws (1) and lock washers (2) and lift off bottom cover (3).
2. Reach through heater case opening (4) and disconnect louver linkages from louvers.
3. Remove right-hand and left-hand louver panels (5 and 6) by unlocking eight studs (7).

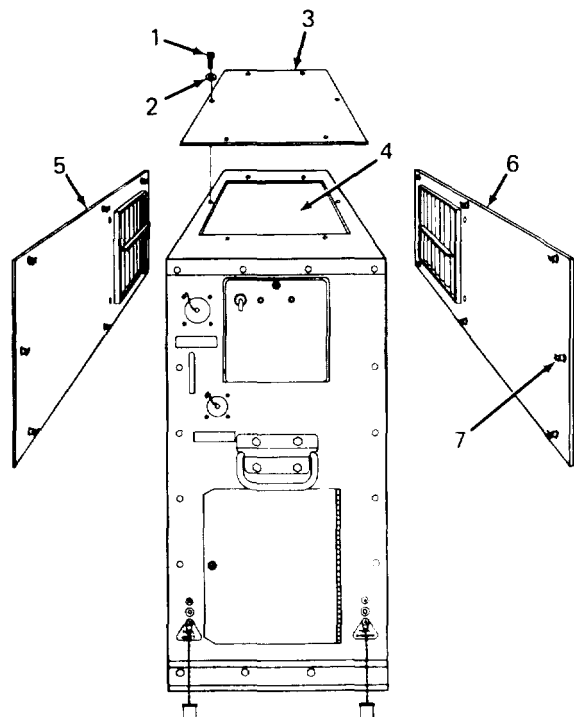

REMOVE/INSTALL VENTILATING AIR MOTOR (CONT)

WARNING

Death or serious injury could occur if precautions are not taken when maintaining this equipment. Position HEATER. OFF-FAN switch to OFF and remove power cable plug from POWER RECEPTACLE. Remove electrical charge from ventilating motor capacitor C3 by shorting out contacts using tool having insulated handle. Always disconnect power cable before making continuity tests or before repairing heater. Always have another person standing by who is trained in electric shock first aid.

4. Disconnect red wire (8) of ventilating air motor (9) from red wire of PC board.
5. Tag and disconnect white wire (10) from capacitor (11).
6. Tag and disconnect brown wire (12) and white wire (13) of motor (9) from capacitor (11). Remove wires (10, 12, and 13) from capacitor boot (14).

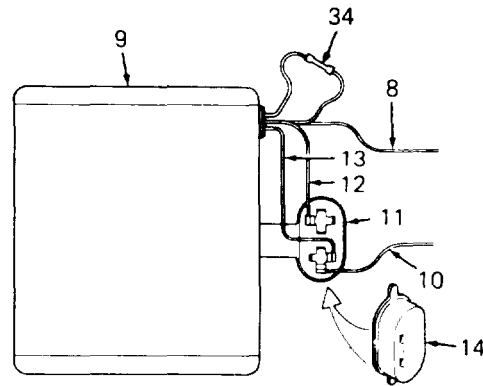

7. Remove four screws (15), lock washers (16), and flat washers (17) and lift out assembled ventilating air motor (9) and motor mount (18).
8. Remove screw (19), lock washer (20), and nut (21) and lift off capacitor (11). This step also disconnects one end of ground strap (22). To disconnect opposite end, remove nut (23) and lock washer (24).
9. To remove capacitor (11) from mounting bracket (25), loosen screw (26), and slide capacitor out endwise.
10. Remove screw (27), lock washer (28), and nut (29). Separate halves of motor mount (18).
11. Loosen set screws (30) and remove fan blades (31).
12. Motor cushion (32) can be removed by sliding off end of motor (9) in direction away from motor wires.

CAUTION

Do not remove butt connector (34).

13. If butt connector (34) is accidentally loosened or removed, reconnect wires (35 and 36) using new butt connector.

REMOVE/INSTALL VENTILATING AIR MOTOR (CONT)

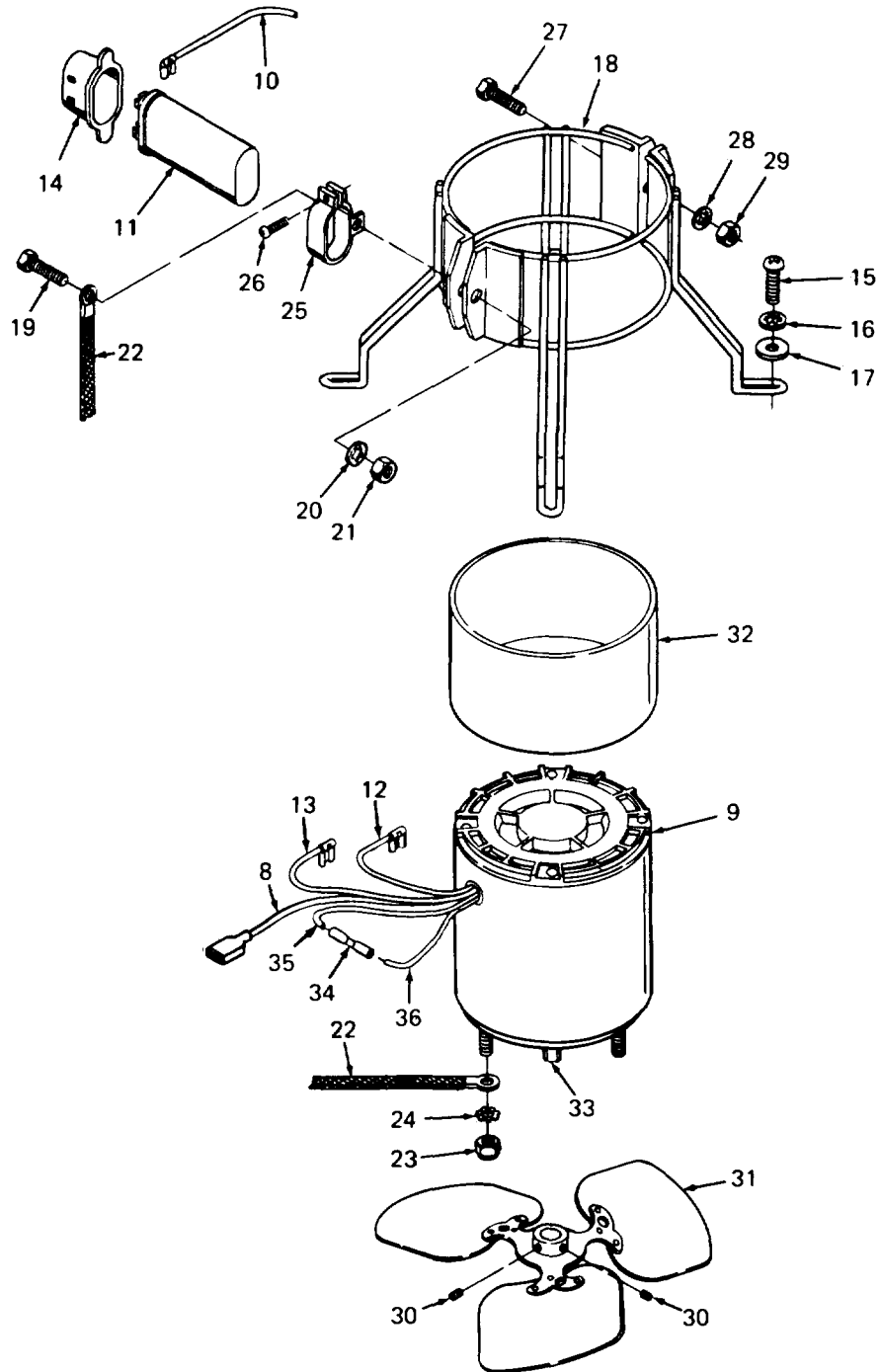

REMOVE/INSTALL VENTILATING AIR MOTOR (CONT)

INSTALLATION:

1. If motor cushion (32) was removed, slide onto ventilating air motor (9) from end opposite motor wires.
2. Install fan blades (31) and secure with set screws (30). Motor shaft (33) is Provided with recesses which must be aligned with ends of set screws before tightening. When set screws are seated in recesses, fan blades are in proper position on motor shaft.
3. Install capacitor (11) in mounting bracket (25) and tighten screw (26).
4. Loosely connect halves of motor mount (18) on one side using screw (27), lock washer (28), and nut (29).
5. Place motor (9) in gripping portion of motor mount (18) with fan blades (31) facing down. Insert screw (19) through one terminal of ground strap (22), hole in mounting bracket (25), and holes in halves of motor mount (18). Complete attachment using lock washer (20) and nut (21).
6. Tighten screws (19 and 27) enough to hold motor (9). Secure opposite end of ground strap (22) using lock washer (24) and nut (23).
7. Install assembled motor (9) and motor mount (18) using four screws (15), lock washers (16), and flat washers (17). Do not tighten screws.

CAUTION

Ventilating air motor fan blades must be centered in flanged opening in exchanger housing bottom panel.

8. With screws (15) loose, motor (9) can be adjusted horizontally. Adjust motor until fan blades are centered in opening in exchanger housing bottom panel. Make adjustment by eye. Tighten four screws (15).
9. Adjust motor (9) vertically in motor mount (18) until one-third of depth of fan blades (31) projects below flange of opening in exchanger housing bottom panel. Make measurement by eye, Tighten screws (19 and 27).

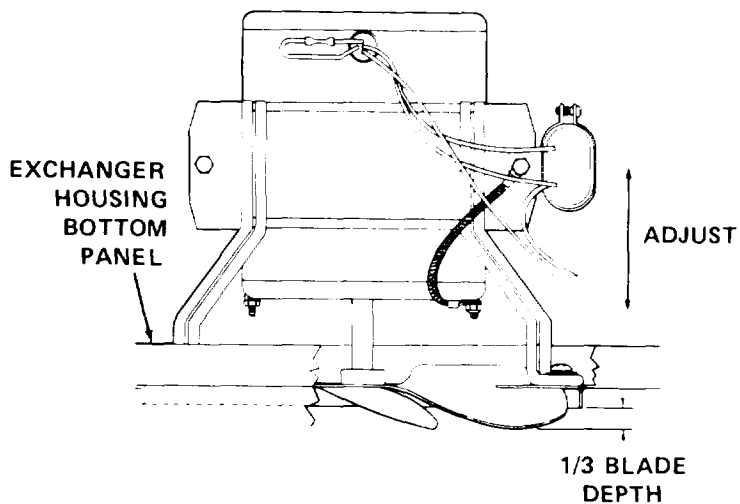

REMOVE/INSTALL VENTILATING AIR MOTOR (CONT)

10. Project brown wire (12) and white wire (13) of motor (9), and white wire (10), through openings in capacitor boot (14). Connect wires to capacitor (11) as illustrated.
11. Connect red wire (8) to red wire of PC board.

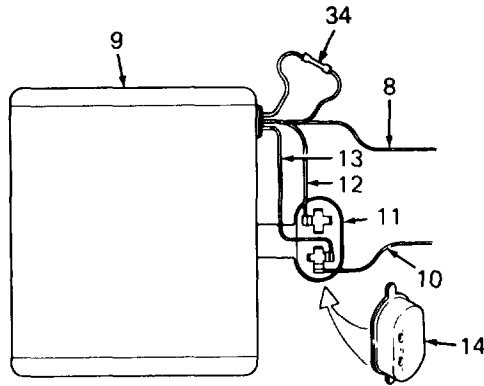

12. Install right-hand and left-hand louver panels (5 and 6). Secure each panel by locking eight studs (7).
13. Reach through heater case opening (4) and connect louver linkages to louvers
14. Install bottom cover (3) using six screws (1) and lock washers (2).

TEST VENTILATING AIR MOTOR

TEST EQUIPMENT:

AC ammeter
Tachometer, strobotac

TOOLS: Tool kit, service, refrigeration unit
NSN 5180-00-596-1474

GENERAL SAFETY INSTRUCTIONS:

Power off.
Heater cool.

TESTING:

WARNING

Death or serious injury could occur if precautions are not taken when maintaining this equipment. Position HEATER-OFF-FAN switch to OFF, remove power cable plug from POWER RECEPTACLE, and ground capacitors C1 and C2 prior to gaining access to heater compartments. Terminals of capacitors are accessible at end cover of combustion blower. Always have another person standing by who is trained in electric shock first aid.

Remove electrical charge from ventilating air motor capacitor C3 by shorting out contacts using tool having insulated handle.

Allow sufficient time for heater to cool to room temperature before gaining access to heater compartments.

1. Remove six screws (1) and lock washers (2) and lift off bottom cover (3).
2. Reach through heater case opening (4) and disconnect louver linkage from louvers of right-hand louver panel (5).
3. Remove right-hand louver panel (5) by un-locking eight studs (6).

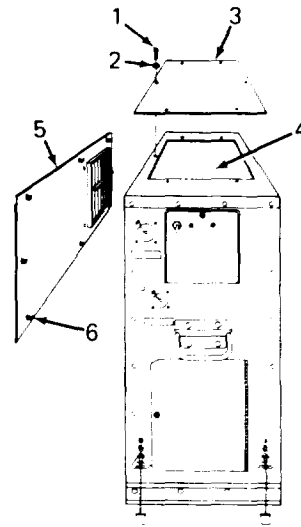

TEST VENTILATING AIR MOTOR (CONT)

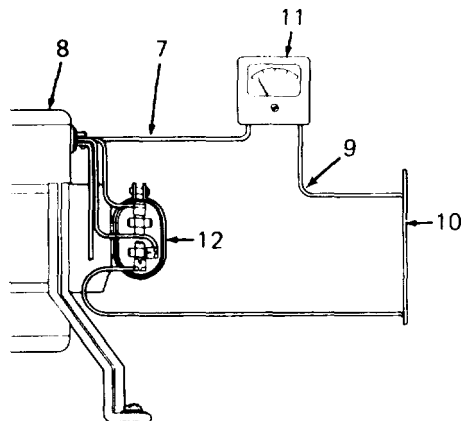

4. Disconnect red wire (7) of ventilating air motor (8) from red wire (9) of PC board (10).
5. Connect ac ammeter (11) in series with red wires (7 and 9).
6. Plug in power cable at POWER RECEPTACLE and position HEATER-OFF-FAN switch to FAN.
7. With motor (8) operating under fan load, current draw shall not exceed 5.4 amperes.
8. Use tachometer to check motor speed. Motor speed should be 2950 rpm at 50 Hz and 3500 rpm at 60 Hz.
9. If current draw is too high or motor speed is too low, test motor capacitor (12) in accordance with TEST VENTILATING AIR MOTOR CAPACITOR, TESTING, page 4-60. If capacitor is good and motor (8) still does not meet requirements, replace motor. No repair is authorized.
10. If motor (8) does not start when HEATER-OFF-FAN switch is turned to FAN, use tool and manually spin fan blades. If motor starts, replace capacitor and then follow above testing procedure.

TEST VENTILATING AIR MOTOR CAPACITOR

TEST EQUIPMENT: Volt ohmmeter

TOOLS: Tool kit, service, refrigeration unit
NSN 5180-00-596-1474

GENERAL SAFETY INSTRUCTIONS:

Power off.
Heater cool.

TESTING:

WARNING

Death or serious injury could occur if precautions are not taken when maintaining this equipment. Position HEATER-OFF-FAN switch to OFF, remove power cable plug from POWER RECEPTACLE, and ground capacitors C1 and C2 prior to gaining access to heater compartments. Terminals of capacitors are accessible at end cover of combustion blower. Always disconnect power cable before making continuity tests or before repairing heater. Always have another person standing by who is trained in electric shock first aid.

Remove electrical charge from ventilating air motor capacitor C3 by shorting out contacts using tool having insulated handle.

Allow sufficient time for heater to cool to room temperature before gaining access to heater compartments.

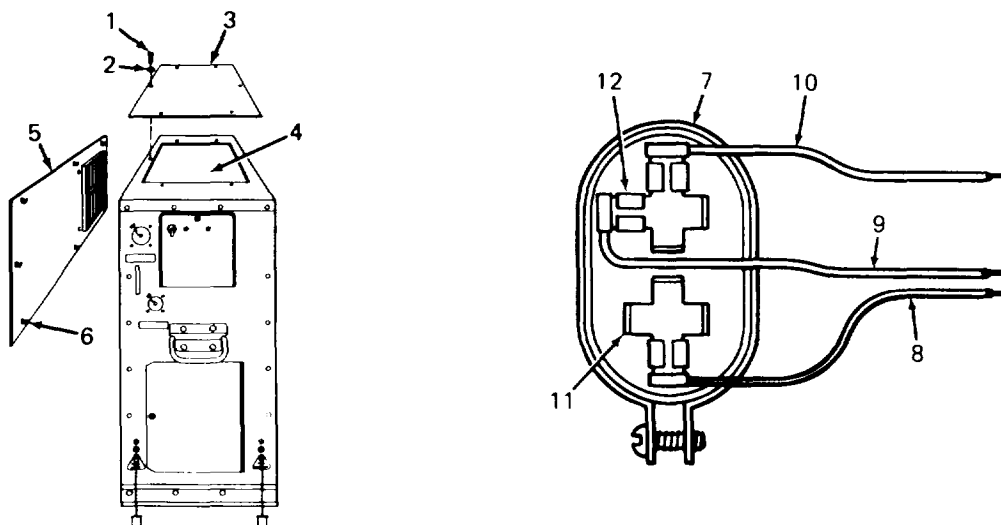

1. Remove six screws (1) and lock washers (2) and lift off bottom cover (3).

TEST VENTILATING AIR MOTOR CAPACITOR (CONT)

2. Reach through heater case opening (4) and disconnect louver linkage from louvers of right-hand louver panel (5).
3. Remove right-hand louver panel (5) by unlocking eight studs (6).
4. Pull capacitor boot away from end of capacitor (7). Tag and disconnect brown wire (8) and two white wires (9 and 10).
5. Set volt ohmmeter on R x 100.
6. Put one probe against each capacitor terminal (11 and 12). Meter should show a reading of infinity.
7. Reverse the probes on the terminals. Reading should jump to 15,000 ohms and immediately fall back to infinity.
8. If meter fails to react as described, capacitor is defective. Replace.

BURNER HEAD ASSEMBLY PROCEDURES INDEX

PROCEDURE	PAGE
Remove/Install Burner Head Assembly	4-62
Repair Burner Head Assembly	4-65

REMOVE/INSTALL BURNER HEAD ASSEMBLY

TOOLS: Tool kit, service, refrigeration unit
NSN 5180-00-596-1474

MATERIALS/PARTS: Dry cleaning solvent (Item 13, Appendix E)

REFERENCES:

Page 4-95 Inspect/Service/Adjust/Remove/Install Carburetor, Removal
Page 4-96 Inspect/Service/Adjust/Remove/install Carburetor, Installation

GENERAL SAFETY INSTRUCTIONS:

Power off.
Heater cool.

REMOVAL:

WARNING

Death or serious injury could occur if precautions are not taken when maintaining this equipment. Position HEATER-OFF-FAN switch to OFF, remove power cable plug from POWER RECEPTACLE, and ground capacitors C1 and C2 prior to gaining access to heater compartments. Terminals of capacitors are accessible at end cover of combustion blower. Always have another person standing by who is trained in electric shock first aid.

Allow sufficient time for heater to cool to room temperature before gaining access to heater compartments.

1. Close shutoff valve at fuel container.
2. Open side heater case door and front access door.

REMOVE/INSTALL BURNER HEAD ASSEMBLY (CONT)

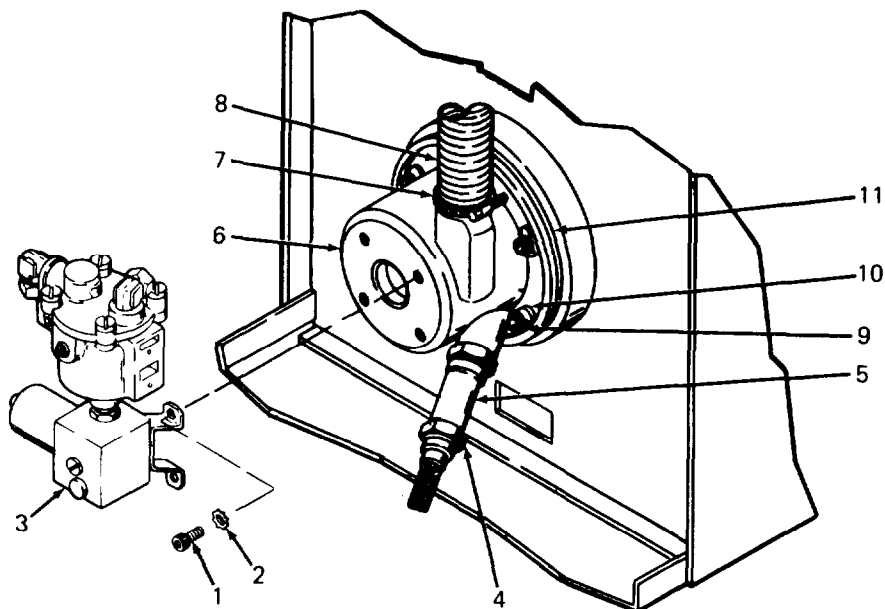
**WARNING**

Death or serious injury could occur if fuel is not handled carefully. Use in a well-ventilated area away from open flame, arcing equipment, ignition sources, heaters, or excessive heat. Engines must be turned off and cool before refueling. Use proper refueling procedures and equipment to avoid spillage. Do not run engines near open fuel containers. Do not use fuel as a cleaning solvent. **DO NOT SMOKE.**

3. Remove four screws (1) and lock washers (2). Pull off carburetor (3) and move out of the way. Small amount of fuel may be spilled during this procedure. For complete removal of carburetor, refer to INSPECT/SERVICE/ADJUST/REMOVE/INSTALL CARBURETOR, REMOVAL, page 4-95.
4. Disconnect ignition cable (4) from igniter assembly (5). Remove igniter assembly from burner head assembly (6).
5. Loosen hose clamp (7) and disconnect combustion blower air duct (8) from burner head assembly (6).
6. Remove five screws (9) and pressure pads (10) and lift out burner head assembly (6). Gasket (11) may stick to flange of burner head assembly. If gasket is not damaged, it may be reused.

REMOVE/INSTALL BURNER HEAD ASSEMBLY (CONT)

INSTALLATION:

CAUTION

Do not tighten burner head mounting screws (9) until all screws are loosely installed. Follow tightening instructions exactly.

1. Loosely install burner head assembly (6) and gasket (11) using five screws (9) and pressure pads (10). Assembled parts should barely touch.
2. Tighten every other screw (9) around flange of burner head assembly (6) to 15.0 to 25.0 in. lb (1.7 to 2.8 N•m) of torque until all screws have been tightened.
3. Tighten every other screw (9) around flange of burner head assembly (6) to 50.0 to 60.0 in. lb (5.7 to 6.8 N•m) of torque until all screws have been tightened.
4. Connect combustion blower air duct (8) to burner head assembly (6) using hose clamp (7). Tighten hose clamp firmly.
5. Install igniter assembly (5) in burner head assembly (6). Connect ignition cable (4) to igniter assembly.
6. Install carburetor (3) on burner head assembly (6) using four screws (1) and lock washers (2). If carburetor was completely removed, refer to INSPECT/SERVICE/ADJUST/REMOVE/INSTALL CARBURETOR, INSTALLATION, page 4-96.
7. Close and lock side heater case doors and front access door.
8. If heater is to be operated, open shutoff valve at fuel container.

REPAIR BURNER HEAD ASSEMBLY

TOOLS: Tool kit, service, refrigeration unit
NSN 5180-00-596-1474

MATERIALS/PARTS: Dry cleaning solvent (Item 13, Appendix E)

EQUIPMENT CONDITION:

<u>Page</u>	<u>Condition Description</u>
4-62	Burner head assembly removed.

REPAIR:

Repair consists primarily of cleaning burner head assembly and replacing burner head gasket. Proceed as follows:

1. Use wire brush to remove combustion deposits. If gasket is stuck to burner head, carefully pry off.

WARNING

Dry cleaning solvent P-D-680 (safety or Stoddard's Solvent) is potentially dangerous. Avoid repeated and prolonged breathing of vapors and skin contact with the liquid. Do not use near open flame, arcing equipment, or other ignition sources. Always wear eye protection and protective clothing, Flash point of P-D-680 is 100° to 138° F (38° to 59°C).

Death or serious injury could occur if compressed air is directed against the skin. Do not use compressed air for cleaning or drying unless the pressure is/has been reduced to 30 psi (207 kPa) or less. When working with compressed air always use chip guards, eye protection, and other personal protective equipment.

2. Clean burner head assembly with P-D-680 dry cleaning solvent. Shake off excess solvent and dry with compressed air.
3. Wipe gasket with rag dampened with P-D-680 dry cleaning solvent.

REPAIR BURNER HEAD ASSEMBLY (CONT)

4. Check deflector tube (1) and metering ring (2) for broken welds.
5. Check cone (3) and vane plate (4) for looseness and distortion. Check for burned or eroded areas indicating general deterioration.
6. Check blower tube (5) and igniter seat (6) for cracked or broken brazing. Check threads of igniter seat for stripping.
7. Minor dents may be straightened. Replace burner head assembly having cracks, holes, loose baffles, stripped threads, or showing advanced deterioration.
8. Replace gasket if copper cover on gasket is cracked or badly distorted.

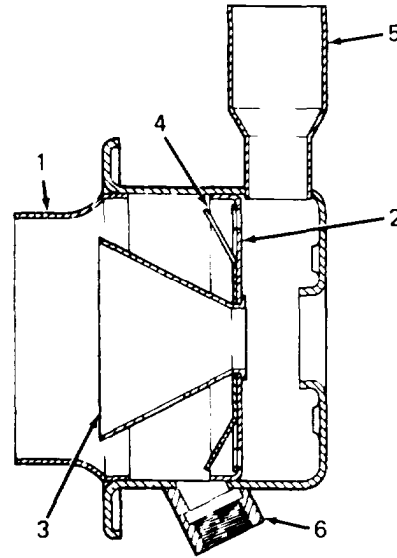

HEAT EXCHANGER PROCEDURES INDEX

	PAGE
Remove/Install Heat Exchanger	4-67
Clean/Inspect/Repair Heat Exchanger	4-72

REMOVE/INSTALL HEAT EXCHANGER

TOOLS: Tool kit, service, refrigeration unit
NSN 5180-00-596-1474

MATERIALS/PARTS: Silicone sealant (Item 11, Appendix E)

GENERAL SAFETY INSTRUCTIONS:

Power off.
Heater cool.

REMOVAL:

WARNING

Death or serious injury could occur if precautions are not taken when maintaining this equipment. Position HEATER-OFF-FAN switch to OFF, remove power cable plug from POWER RECEPTACLE, and ground capacitors C1 and C2 prior to gaining access to heater compartments. Terminals of capacitors are accessible at end cover of combustion blower. Always have another person standing by who is trained in electric shock first aid.

Allow sufficient time for heater to cool to room temperature before gaining access to heater compartments.

1. Open access door (1). Locate thermostat mounting bracket (2) and flame switch and bracket assembly (3).
2. Remove two screws (4) and lock washers (5) at bracket (2) and lift out thermostat (6).
3. Remove two screws (7) and lock washers (8). Lift out flame switch and bracket assembly (3) and thermostat (9).
4. Close shutoff valve at fuel container.

REMOVE/INSTALL HEAT EXCHANGER (CONT)

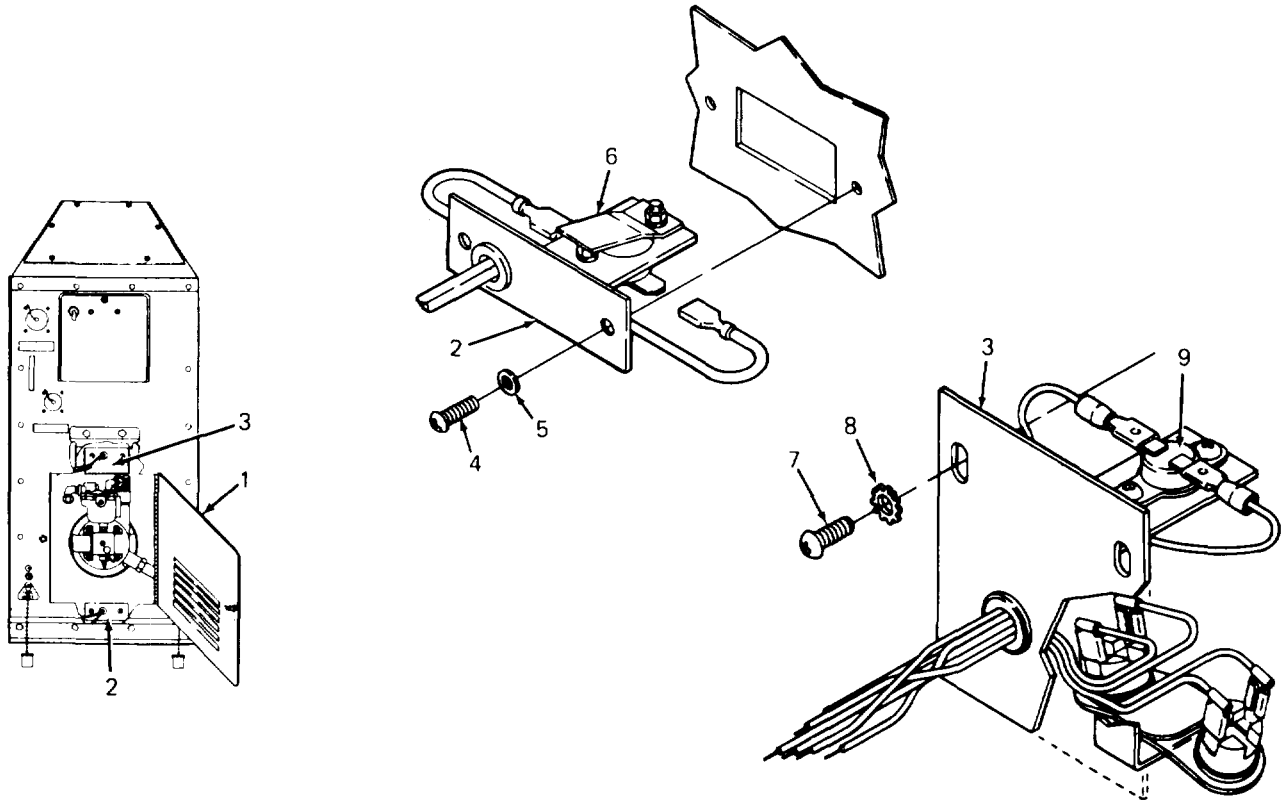

WARNING

Death or serious injury could occur if fuel is not handled carefully. Use in a well-ventilated area away from open flame, arcing equipment, ignition sources, heaters, or excessive heat. Engines must be turned off and cool before refueling. Use proper refueling procedures and equipment to avoid spillage. Do not run engines near open fuel containers. Do not use fuel as a cleaning solvent. **DO NOT SMOKE.**

5. Remove four screws (10) and lock washers (11). Pull off carburetor (12) and move out of the way. Small amount of fuel may be spilled during this procedure.
6. Disconnect ignition cable (13) from igniter assembly (14). Remove igniter assembly from burner head assembly (15).
7. Loosen hose clamp (16) and disconnect combustion blower air duct (17) from burner head assembly (15).

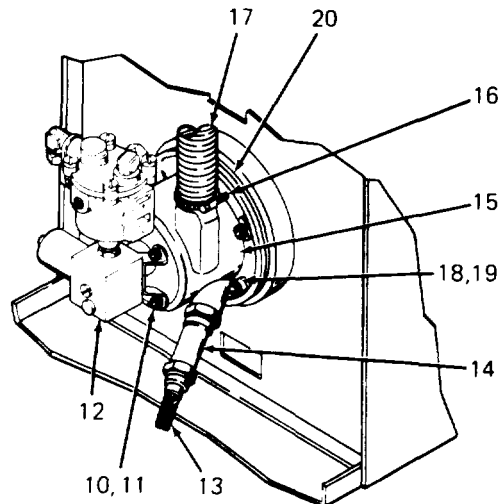

REMOVE/INSTALL HEAT EXCHANGER (CONT)

8. Remove five screws (18) and pressure pads (19) and lift out burner head assembly (15) and gasket (20).
9. Remove eight screws with lock washers (21) securing rear exchanger cover (22).
10. Carefully remove rear exchanger cover (22) with heat exchanger (23) attached.
11. Remove four screws with lock washers (24) attaching rear exchanger cover (22) to heat exchanger (23).
12. Lift out heat exchanger exhaust shield (25) at exhaust end of heat exchanger (23).

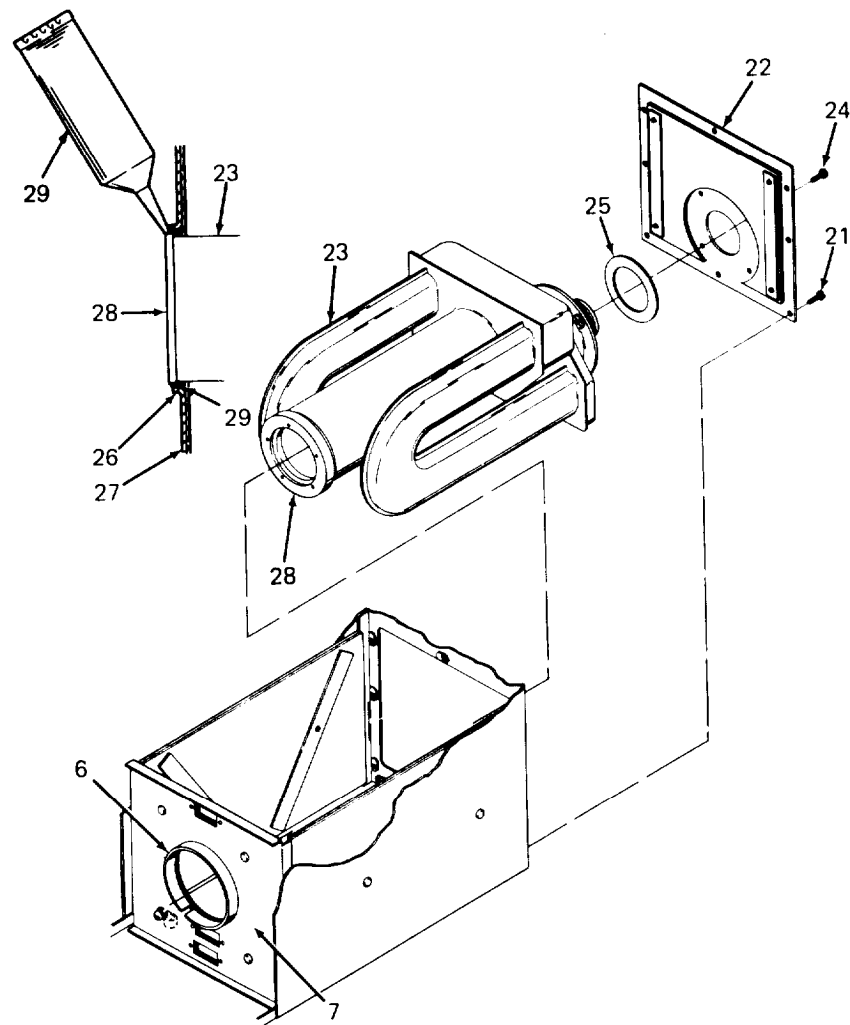

REMOVE/INSTALL HEAT EXCHANGER (CONT)

INSTALLATION:

1. Install heat exchanger exhaust shield (25) at exhaust end of heat exchanger (23).
2. Attach rear exchanger cover (22) to rear of heat exchanger (23) with four screws with lock washers (24).
3. Use sharp knife or similar cutting tool and cut old sealant from inside flange (26) of exchanger housing shield (27). Cut old sealant from outside of burner head adapter ring (28).
4. Insert heat exchanger (23) into heater case and secure rear exchanger cover (22) using eight screws with lock washers (21).

CAUTION

Burner head mounting surface must be free of sealant. If sealant is deposited on mounting surface, remove immediately with wet rag.

5. Inject silicone sealant (29) between flange (26) and adapter ring (28) all the way around ring. Smooth sealant with wet rag or wet finger.
6. Sealant will harden at room temperature. Allow at least 8 hours hardening time before operating heater.

CAUTION

Do not tighten burner head mounting screws (18) until all screws are loosely installed. Follow tightening instructions exactly.

7. Loosely install burner head assembly (15) and gasket (20) using five screws (18) and pressure pads (19). Assembled parts should barely touch.
8. Tighten every other screw (18) around flange of burner head assembly (15) to 15.0 to 25.0 in. lb (1.7 to 2.8 N•m) of torque until all screws have been tightened.
9. Tighten every other screw (18) around flange of burner head assembly (15) to 50.0 to 60.0 in. lb (5.7 to 6.8 N•m) of torque until all screws have been tightened.

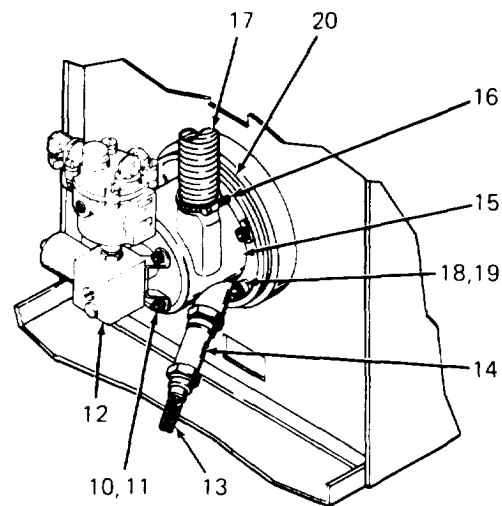

REMOVE/INSTALL HEAT EXCHANGER (CONT)

10. Connect combustion blower air duct (17) to burner head assembly (15) using hose clamp (16). Tighten hose clamp firmly.
11. Install igniter assembly (14) in burner head assembly (15). Connect ignition cable (13) to igniter assembly.
12. Install carburetor (12) on burner head assembly (15) using four screws (10) and lock washers (11).
13. Install flame switch and bracket assembly (3) and thermostat (9) using two screws (7) and lock washers (8).
14. Install thermostat (6) using two screws (4) and lock washers (5) to secure bracket (2).
15. Close access door (1). Open shutoff valve at fuel container if heater is to be operated.
16. Test heated air as described in table 3-2, item 15, to determine carbon monoxide level.

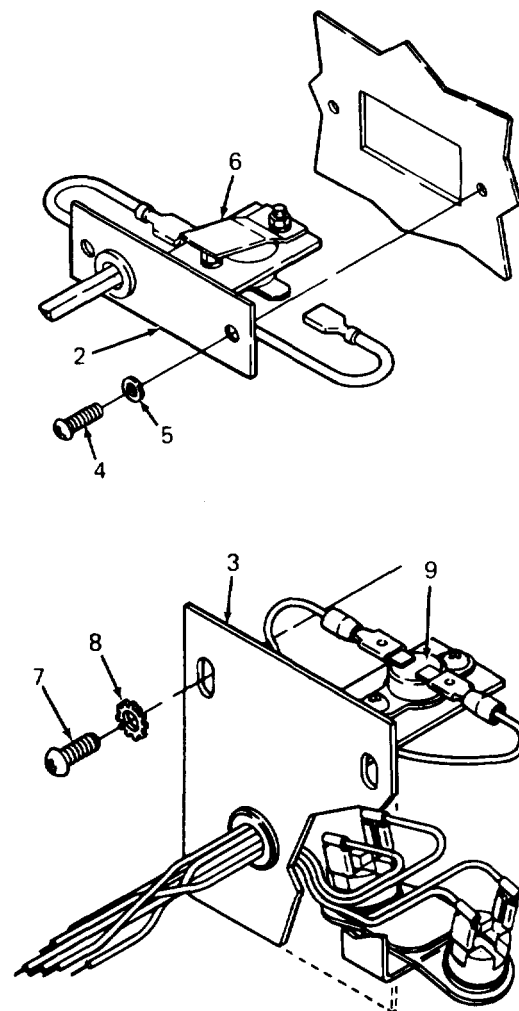
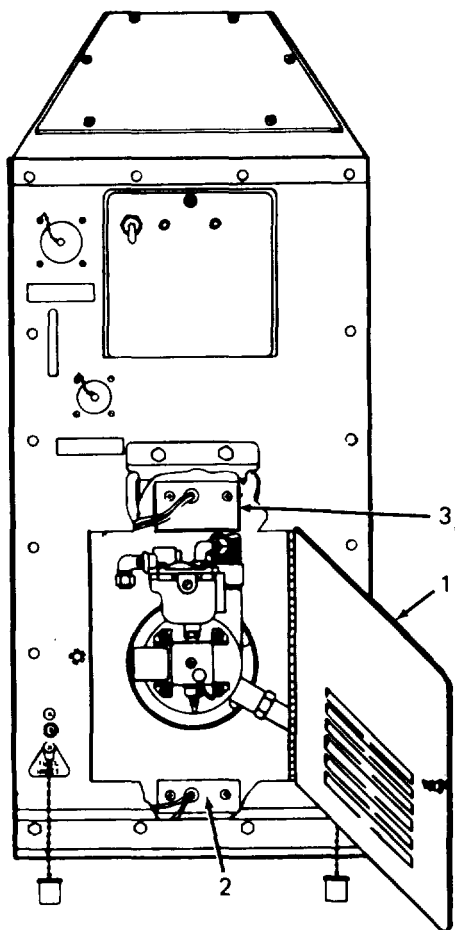

CLEAN/INSPECT/REPAIR HEAT EXCHANGER

MATERIALS/PARTS:

Dry cleaning solvent (Item 13, Appendix E)
Detergent (Item 2, Appendix E)

EQUIPMENT CONDITION:

<u>Page</u>	<u>Condition Description</u>
4-67	Heat exchanger removed.

CLEANING:

WARNING

Dry cleaning solvent P-D-680 (safety or Stoddard's Solvent) is potentially dangerous. Avoid repeated and prolonged breathing of vapors and skin contact with the liquid. Do not use near open flame, arcing equipment, or other ignition sources. Always wear eye protection and protective clothing. Flash point of P-D-680 is 100° to 138° F (38° to 59° C).

NOTE

Clean heat exchanger whenever it is removed for any reason.

1. Remove carbon deposits from heat exchanger by flushing thoroughly with P-D-680 dry cleaning solvent. Shake out excess solvent.
2. Wash heat exchanger by flushing thoroughly with mixture of one part detergent and one part water.
3. Rinse heat exchanger in clear water and shake out excess. Allow to drain from both ends. No special drying method is necessary.

INSPECTION:

1. Inspect heat exchanger for cracks, broken welds, corroded or burned areas, severe dents, and other damage which could cause leakage. Replace damaged heat exchanger.
2. Check exhaust end of heat exchanger for stripped threads. Replace heat exchanger if threads are stripped.

CLEAN/INSPECT/REPAIR HEAT EXCHANGER (CONT)

3. Check heat exchanger insulators behind burner head adapter ring. If insulators are frayed, torn, or otherwise damaged, replace.
4. Check exchanger shield at exhaust end of heat exchanger. If frayed, torn, or otherwise damaged, replace.

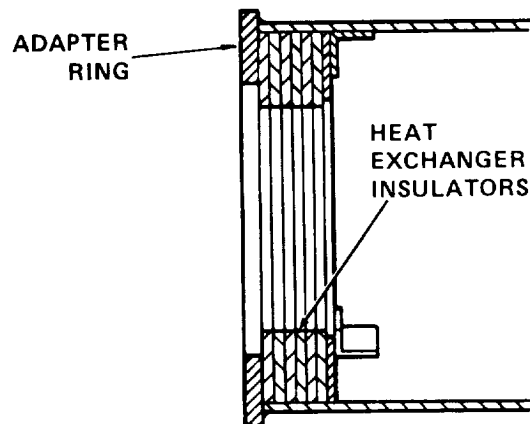
**REPAIR:**

1. Repair to heat exchanger is limited to replacing heat exchanger insulators and exchanger exhaust shield.
2. To replace heat exchanger insulators, pull out damaged insulators and insert new ones. Insulators are flexible and split to facilitate installation.
3. To replace exchanger exhaust shield, lift out of recess at exhaust end of heat exchanger and install new one.
4. Do not attempt to repair any other damage to heat exchanger.

**APPENDIX A
REFERENCES**

A-1. PUBLICATIONS INDEX

The following index should be consulted frequently for latest changes or revisions of references given in this appendix and for new publications relating to material covered in this manual.

Index of Administrative Publications DA Pam 310-1

A-2. FORMS AND RECORDS

Report of Discrepancy SF 364
 Equipment Inspection and Maintenance Worksheet DA Form 2404
 Quality Deficiency Report SF 368
 Recommended Changes to Publications and Blank Forms DA 2028

A-3. TECHNICAL MANUALS

Unit and Intermediate Maintenance Repair Parts and Special Tools
 List, Heater, Space, Multifuel with Blower TM 5-4520-253-23P
 Procedures for Destruction of Equipment to Prevent Enemy Use TM 750-244-3
 The Army Maintenance Management System (TAMMS) DA Pam 738-750

APPENDIX B MAINTENANCE ALLOCATION CHART

Section I. INTRODUCTION

B-1. MAINTENANCE ALLOCATION CHART (MAC)

a. *General.* This MAC assigns maintenance functions in accordance with the Three Level Maintenance concept. The three levels are depicted on the MAC as:

UNIT level - corresponds to an O code in the Repair Parts and Special Tools List (RPSTL). A C code entry under UNIT denotes maintenance performed by the crew or operator within UNIT maintenance.

INTERMEDIATE level - corresponds to an F code in the RPSTL.

DEPOT level - corresponds to a D code in the RPSTL.

b. *Unit Maintenance.* Maintenance to be performed in the Unit level is described as follows:

(1) Unit Maintenance activities are staffed and equipped to perform high frequency on-equipment maintenance tasks required to retain or return equipment to a serviceable condition. These tasks include preventive maintenance and repair and replace functions associated with a high level of mission capability.

(2) Unit Maintenance inspection and servicing include daily (usually performed by operator or crew), periodic, and special inspections, as authorized by the MAC or higher headquarters.

(3) Unit level maintains a Combat Prescribed Load List (PLL) which consists of items on the Mandatory Parts List (MPL) and items which are demand supported.

(4) Unit level performs troubleshooting, replace, and limited repair functions as authorized by the MAC, RPSTL, and applicable technical manuals.

c. *Intermediate Maintenance.* Maintenance to be performed in the Intermediate level is described as follows:

(1) One stop maintenance support through use of mobile weapon system oriented maintenance teams to perform authorized maintenance (that exceeds Unit level capability) to effect quick repair and return to user capabilities.

(2) Maintains a Combat Authorized Stockage List (ASL), Mandatory Parts List (MPL), Direct Exchange (DX), and provides limited Operational Readiness Float (ORF) for supported units.

(3) Provides collection, classification, and recovery services for serviceable and unserviceable materiel and maintains a Battle Damage Assessment (B DA) capability.

(4) Provides maintenance support for the theater supply system through repair of components and DX items.

(5) Provides maintenance units composed of commodity oriented platoons which may be augmented by support teams that deploy forward if the tactical situation permits.

(6) Maintains Operational Readiness Float (ORF) stocks in support of the theater.

d. *Depot Maintenance.* Depot level functions are authorized as indicated by entries in the Depot (D) Maintenance level column (4) in the MAC.

B-2. USE OF THE MAINTENANCE ALLOCATION CHART, SECTION II

a. The MAC assigns maintenance functions based on the following considerations:

- (1) Skills available.
- (2) Work time required.
- (3) Tools and test equipment required and/or available.

b. If a lower level of maintenance identified in column (4) of the MAC cannot perform all tasks of a single maintenance function (e.g., test, repair), than the higher level that can perform other tasks of that function is also indicated.

c. Higher maintenance levels are automatically authorized to perform maintenance functions assigned to a lower maintenance level.

d. Higher maintenance levels will perform the maintenance functions of lower maintenance levels when required or directed by the Commander who has authority to direct such tasking.

e. Assignment of a maintenance function in the MAC does not carry automatic authorization to carry the related spare or repair parts in stock. Information to requisition or secure parts will be as specified in the associated RPSTL.

f. Normally, there will be no deviation from the assigned level of maintenance. However, in cases of operational necessity, maintenance functions assigned a higher level may, at the request of the lower level, be assigned to the lower level on a one-time basis, if specifically authorized by the maintenance officer of the higher level to which the function is assigned. In such a case, the special tools, equipment, etc., required by the lower level to perform this function will be furnished by the higher level assigned the function. Also, transfer of a function to a lower level does not relieve the higher level of responsibility for the function, so the higher level will provide technical supervision and inspection of the function being performed at the lower level.

B-3. MAINTENANCE FUNCTIONS

Maintenance functions will be limited to and defined as follows:

a. *Inspect.* Two levels of inspect are covered in the MAC.

(1) When prescribed at the C or O element of Unit Maintenance level, inspect means to determine serviceability by comparing an item's physical, mechanical, and/or electrical characteristics with established standards through examination (i.e., by sight, sound, or feel). These inspections are included in preventive maintenance (PM) checks and services, such as PMCS, PMD.

(2) When prescribed at the Intermediate (F) or Depot (D) maintenance level, inspect refers to an initial inspection which is conducted prior to scheduling any repair on repairable items evacuated to this level. This inspection is made to determine whether an item qualifies for repair or discard.

b. *Test.* To verify serviceability and detect incipient failure by measuring the mechanical or electrical characteristics of an item and comparing those characteristics with prescribed standards.

c. *Service*. Operations required periodically to keep an item in proper operating condition, i.e., to clean (includes decontaminate), to preserve, to drain, or to replenish fuel, lubricants, hydraulic fluids, or compressed air supplies.

d. *Adjust*. To maintain within prescribed limits, by bringing into proper or exact position, or by setting the operating characteristics to the specified parameters.

e. *Align*. To adjust specified variable elements of an item to bring about optimum or desired performance.

f. *Calibrate*. To determine and cause corrections to be made or to be adjusted on instruments or test measuring and diagnostic equipment used in precision measurement. Consists of comparison of two instruments, one of which is a certified standard of known accuracy, to detect and adjust any discrepancy in the accuracy of the instrument being compared.

g. *Install*. The act of emplacing, seating, or fixing into position an item, part, or module (component or assembly) in a manner to allow the proper functioning of an equipment or system.

h. *Replace*. The act of substituting a serviceable like type part, a subassembly, or module (component or assembly) for an unserviceable counterpart.

i. *Repair*. The application of maintenance services (inspect, test, service, adjust, align, calibrate, or replace) or other maintenance actions (welding, grinding, riveting, straightening, facing, remachining, or resurfacing) to restore serviceability to an item by correcting specific damage, fault, malfunction, or failure in a part, subassembly, module (component or assembly), end item, or system.

j. *Overhaul*. That maintenance effort (service/action) necessary to restore an item to a completely serviceable operational condition as prescribed by maintenance standards in appropriate technical publications (i.e., DMWR). Overhaul is normally the highest degree of maintenance performed by the Army. Overhaul does not normally return an item to a like new condition.

k. *Rebuild*. Consists of those services/actions necessary for the restoration of unserviceable equipment to a like new condition in accordance with original manufacturing standards. Rebuild is the highest degree of materiel maintenance applied to Army equipment. The rebuild operation includes the act of returning to zero those age measurements (hours/miles, etc.) considered in classifying Army equipment/components.

B-4. EXPLANATION OF COLUMNS IN THE MAC, SECTION II

a. *Column (1), Group Number*. Column 1 lists functional group code numbers which are assigned to identify maintenance significant components, assemblies, subassemblies, and modules to their next higher assembly.

b. *Column (2), Component/Assembly*. Column 2 contains the item names of components, assemblies, subassemblies, and modules for which group numbers (column 1) are assigned and for which maintenance is authorized.

c. *Column (3), Maintenance Function*. Column 3 lists the functions to be performed on items listed in column 2. (Function definitions are contained in paragraph B-3.)

d. *Column (4), Maintenance Level*. The maintenance levels, Unit, Intermediate, and Depot, are allotted separate subcolumns within column 4. Entry of a work time figure (such as 1.0, 0.2) in a subcolumn indicates that that level is authorized to perform the function listed in column 3, and the

average time required to do the function is the work time figure. If the number or complexity of tasks within a maintenance function varies from one maintenance level to another, the applicable work time figure for each level will be entered for that function. The work time figure represents the average time it takes to restore a component/assembly to a serviceable condition under a typical field operating environment.

e. *Column (5), Tools and Equipment.* Column 5 specifies, by code, common tool sets (not individual tools from those sets), common TMDE, and special tools, TMDE, and support equipment required to perform a designated function. The code in Column 5 keys to the listing in Section III of the MAC.

f. *Column (6), Remarks.* This column, when applicable, contains a letter code which is keyed to an explanation of the code contained in Section IV of the MAC.

B-5. EXPLANATION OF COLUMNS IN THE MAC, SECTION III

a. *Column (1), Tool or Test Equipment Reference Code.* The tool or test equipment reference code correlates with a code used in the MAC, Section II, Column 5.

b. *Column (2), Maintenance Category.* The lowest category of maintenance authorized to use the tool or test equipment.

c. *Column (3), Nomenclature.* Name or identification of the tool or test equipment.

d. *Column (4), National/NATO Stock Number.* The national stock number of the tool or test equipment.

e. *Column (5), Tool Number.* The manufacturer's part number.

B-6. EXPLANATION OF COLUMNS IN THE MAC, SECTION IV

a. *Column (1), Reference Code.* The code recorded in Column 6, Section II

b. *Column (2), Remarks.* This column lists information pertinent to the maintenance function being performed as indicated in the MAC, Section II.

Section II. MAINTENANCE ALLOCATION CHART — Continued

(1) Group Number	(2) Component/Assembly	(3) Maintenance Function	(4) Maintenance Level			(5) Tools and Eqpt	(6) Remarks	
			Unit	Inter-mediate	Depot			
01	CONTROL BOX ASSEMBLY							
	Control Box	Inspect Replace	0.2 0.2			1		
	Receptacle, ROOM THERMO	inspect Replace	0.2 1.0			1		
	CIRCUIT BREAKER	Inspect Replace Test	0.2 0.2 0.2			1		
	RESET Circuit Breaker	Inspect Replace Test	0.2 0.2 0.2			1		
	Wiring Harness	Repair	1.0			1		
	HEATER-OFF-FAN Switch	Inspect Test Replace	0.2 0.2 0.5			1,2		
	HEAT and FAULT Lights	Replace	0.3			1,2	A	
	Receptacles, POWER and EXTERNAL FUEL PUMP	Inspect Replace	0.2 1.0			1		
	Printed Circuit (PC) Board Assembly	Inspect Repair Replace Test	0.2	0.5 1.0 0.3		1 1 1		
	02	HEATER CASE ASSEMBLY	Inspect Service Repair	0.1 0.2	1.0		1 1	
		Side Panels and Louver Linkage	Adjust Inspect Service Replace	0.2 0.2 0.2 0.2			1 1 1	

Section II. MAINTENANCE ALLOCATION CHART - Continued

(1) Group Number	(2) Component/Assembly	(3) Maintenance Function	(4)			(5) Tools and Eqpt	(6) Remarks			
			Maintenance		Level					
			Unit	Inter-mediate	Depot					
02	HEATER CASE ASSEMBLY - Cont	Doors and Bottom Cover	Adjust			1				
			Inspect	0.2						
			Service	0.2						
			Replace	0.2			1			
		Data Plates	Inspect	0.2						
			Replace	0.5						
		Labels	Inspect	0.2						
			Replace	0.2						
		03	FUEL SYSTEM	Fuel Lines and Fittings	Inspect	0.5				
					Repair	0.5			1	
Replace	0.5						1			
Fuel Filter	Service			0.5						
	Replace			0.5			1			
Carburetor	Inspect			0.2						
	Service			0.2			1			
	Adjust			0.1			1			
	Replace			1.0			1			
Solenoid	Inspect			0.3						
	Test			0.5						
	Replace			0.5			1	B		
04	ELECTRICAL			Combustion Blower	Inspect	0.2				
					Repair		0.5		1,4	A
					Replace		0.5		1	
		Test			0.5		7, 8, 9			
		Ventilating Air Motor	Inspect	0.2						
			Replace		0.5		1			
			Test		0.5					
							1,5,6			

Section II. MAINTENANCE ALLOCATION CHART — Continued

(1) Group Number	(2) Component/Assembly	(3) Maintenance Function	(4) Maintenance Level			(5) Tools and Eqpt	(2) Remarks
			Unit	Inter-mediate	Depot		
04	ELECTRICAL - Cont						
	Individual Wires, Assemblies, and Terminals	Repair	0.5			1,3	
	Safety Thermostats and Flame Switch and Bracket Assembly	Inspect	0.2				
		Test	0.5				
	Replace	0.3			1		
05	BURNER ASSEMBLY	Repair		1.0		1	
		Replace		1.0		1	
	Ignition Transformer and Cable	Replace	0.3			1	
		Test	0.2				
		Repair	0.2			1	
	Igniter	Service	0.3				
Replace		0.3					
06	HEAT EXCHANGER	Replace		2.0		1,10	
		Repair		2.0			
07	ACCESSORY ITEMS	Room Thermostat	Test	0.5		1	
			Adjust	0.1			
			Replace	0.5			1
	Side Heater Case Covers	Replace	0.1			1	
	Plugs: Power, Fuel Pump, and Room Thermostat	Replace	0.3			1	

Section III. TOOL AND TEST EQUIPMENT REQUIREMENTS

(1) Tool or Test Equipment Ref Code	(2) Maintenance Category	(3) Nomenclature	(4) National/ NATO Stock Number	(5) Tool Number
1	O, F	Tool Kit, Service, Refrigeration Unit	5180-00-596-1474	(19099) SC5180- 90-C L- N18
2	O, F	Solder Gun Kit	3439-00-930-1638	(11103) 450K4
3	O, F	Thermometer [range up to 300° F (149°C)]		
4	F	Puller, Bearing	5120-00-766-3176	(45225) 1002
5	F	Ammeter, AC		
6	F	Tachometer, Strobotac	6625-00-799-7616	(24655) 1531A
7	F	Rubber Hose, 1/4-inch ID, 36-inch length		
8	F	Needle, Inflating, Football		
9	F	Jar or Glass, Tall (at least 16-inch water capacity)		
10	O, F	Tester, Carbon Monoxide		

Section IV. REMARKS

(1) Reference Code	(2) Remarks
A B	Replace all used butt connectors Replace used O-ring

APPENDIX C
COMPONENTS OF END ITEMS AND BASIC ISSUE ITEMS LIST

Section I. INTRODUCTION

C-1. SCOPE

This appendix lists Integral Components of the Basic Issue Items (BII) space heater to help you inventory items required for safe and efficient operation.

C-2. GENERAL

The components of end item list are divided into the following sections:

a. *Section II, Integral Components of the End Item.* These items when assembled, comprise the space heater and must accompany it whenever it is transferred or turned in. The illustrations will help you identify these items.

b. *Section III, Basic Issue Items.* These are minimum essential items required to place the space heater in operation, to operate it, and to perform emergency repairs. Although shipped separately packed, they must accompany the space heater during operation and whenever it is transferred between accountable officers. The illustrations will assist you with hard-to-identify items. This manual is your authority to requisition replacement BII based on Table(s) of Organization and Equipment (TOE)/Modification Table of Organization and Equipment (MTOE) authorization of the end item.

C-3. EXPLANATION OF COLUMNS

a. *Column (1), Figure Number.* Indicates the figure number of the illustration showing the item.

b. *Column (2), National Stock Number (NSN).* Indicates the national stock number assigned to the end item which will be used for requisitioning.

c. *Column (3), Description FSCM & Part No.* Indicates the Federal item name. The last line for each item indicates the FSCM followed by the part number.

d. *Column (4), Unit of Measure (U/M).* Indicates the measure used in performing the actual operation/maintenance function.

e. *Column (5), Quantity Required (Qty Reqd).* Indicates the quantity of the item authorized to be used with/on the equipment.

Section II. INTEGRAL COMPONENTS OF END ITEM

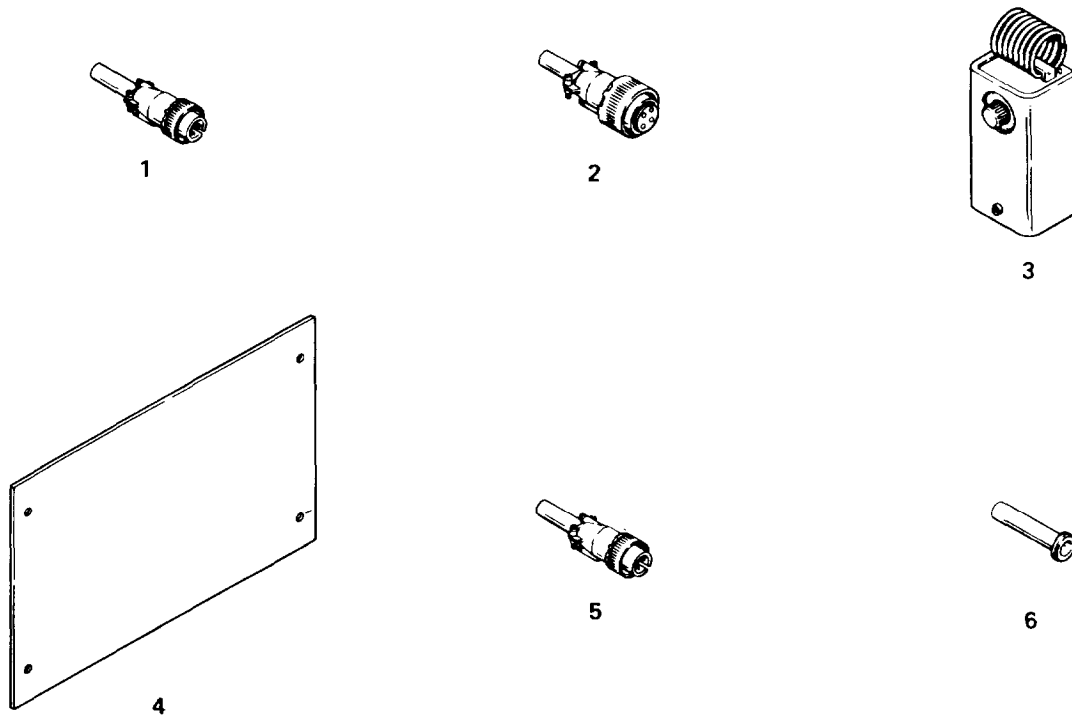

(1) Figure No.	(2) NSN	(3) Description FSCM & Part No.	(4) U/M	(5) Qty Reqd
1	5935-00-581-1080	Plug, Fuel Pump Connector (96906) MS3106E14S9P	each	1
2	5935-00-556-6114	Plug, Power (96906) MS3106E18-10S	each	1
3	6685-00-893-9020	Thermostat, Room (92878) 68279	each	1
4		Cover, Side (92878) 68635-07	each	2
5	5935-00-201-6655	Plug, Room Thermostat (96906) MS3106E14S7P	each	1
6	5365-00-663-2125	Bushing (96906) MS3420-10	each	1

Section III. BASIC ISSUE ITEMS

(2) NSN	(3) Description FSCM & Part No.	(4) U/M	(5) Qty Reqd
	Case, Manual	each	1
	Department of Army Technical Manual; OPERATOR'S, UNIT, AND INTERMEDIATE MAINTENANCE MANUAL TM 5-4520-253-13	each	1

APPENDIX D
ADDITIONAL AUTHORIZATION LIST

Section I. INTRODUCTION

D-1. SCOPE

This appendix lists additional items you are authorized for the support of the heater.

D-2. GENERAL

This list identifies items that do not have to accompany the heater and that do not have to be turned in with it. These items are all authorized to you by CTA, MTOE, TDA, or JTA.

D-3. EXPLANATION OF LISTING

National stock numbers, descriptions, and quantities are provided to help you identify and request the additional items you require to support this equipment. The items are listed in alphabetical sequence by item name under the type document (i.e., CTA, MTOE, TDA, or JTA) which authorized the item(s) to you.

Section II. ADDITIONAL AUTHORIZATION LIST

(1) National Stock Number	(2) Description FSCM and Part Number	Usable on Code	(3) U/M	(4) Qty Auth
2910-00-710-6054	() AUTHORIZED ITEMS (96906) MS51321-1 Fuel Pump, External		each	1

APPENDIX E
EXPENDABLE SUPPLIES AND MATERIALS LIST

Section I. INTRODUCTION

E-1. SCOPE

This appendix lists expendable supplies and materials you will need to operate and maintain the space heater. These items are authorized to you by CTA50-970, Expendable Items (except Medical, Class V, Repair Parts, and Heraldic Items).

E-2. EXPLANATION OF COLUMNS

a. *Column (1), Item Number.* This number is assigned to the entry in the listing and is referenced in the narrative instruction to identify the material (e.g., Use antiseize compound, Item 1, Appendix E).

b. *Column (2), Level.* This column identifies the lowest level of maintenance that requires the listed item.

- C – Operator/Crew
- O – Unit Maintenance
- F – Intermediate Maintenance

c. *Column (3), National Stock Number (NSN).* This the National stock number assigned to the item; use it to request or requisition the item.

d. *Column (4), Description.* Indicates the Federal item name and, if required, a description to identify the item. The last line for each item indicates the part number followed by the Federal Supply Code for Manufacturer (FSCM) in parentheses, if applicable.

e. *Column (5), Unit of Measure (UM).* Indicates the measure used in performing the actual maintenance function. If the unit of measure differs from the unit of issue, requisition the lowest unit of issue that will satisfy your requirements.

Section II. EXPENDABLE SUPPLIES AND MATERIALS LIST

(1) Item Number	(2) Level	(3) National Stock Number	(4) Description	(5) U/M
1	C	8030-00-251 -3980/ 8030-00-059-2761	Compound, Antiseize, MIL-A-907, 1 gal can	1 OZ (30 cm ³)
2	F		Detergent	8 oz (237 cm ³)
3	F	8010-00-111-8336	Enamel, Alkyd, Camouflage, MIL-E- 52798, 1 gal can (prime per TT-P-636)	ea
4	C	9140-00-286-5283	Fuel, Diesel, Arctic, VV-F-800, DF-A (2 gallons required for 8 hour operation)	bulk
5	C	9140-00-286-5294	Fuel, Diesel, Regular, VV-F-800, DF-2 (2 gallons required for 8 hour operation)	bulk
6	C	9140-00-286-5286	Fuel, Diesel, Winter, VV-F-800, DF-1 (2 gallons required for 8 hour operation)	bulk
7	C	9130-00-160-1818	Gasoline, Combat, MIL-G-3056, Type 1 (2 gallons required for 8 hour operation)	bulk
8	O		Oil, Preservative, VV-L-800	bulk
9	F		Sandpaper, 00	
10	F		Sealant, RTV-108 RS No. 10635, Tube, MI L-A-46106	1 oz (30 cm ³)
11	F	8040-00-828-7385	Sealant, Silicone, RTV-732 (71984), Tube	1 oz (30 cm ³)
12	O		Solder, Tin Alloy, QQ-S-571	1 oz (28 g)
13	O	6850-00-264-9038	Solvent, Dry Cleaning, P-D-680, 5 gal- lon container	ar
14	F		Tape, RS No. 10623, Roll, TT-P-60	6 in. (152 mm)

**APPENDIX F
ILLUSTRATED LIST OF MANUFACTURED ITEMS**

Section I. INTRODUCTION

F-1. SCOPE

This appendix includes complete instructions for making items authorized to be manufactured or fabricated by organizational or unit maintenance.

F-2. GENERAL

This appendix includes simplified line drawing illustrations for each item authorized to be manufactured/fabricated by organizational or unit maintenance personnel [i.e., all MO source coded items authorized in the applicable repair parts and special tools list (RPSTL)]. Supporting text supplies all instructional criteria needed to manufacture/fabricate the item(s).

F-3. EXPLANATION OF LISTING

A list of bulk materials to be used in manufacture/fabrication of each item and (when applicable) the part number of the item are included.

Section II. ILLUSTRATED LIST OF MANUFACTURED ITEMS

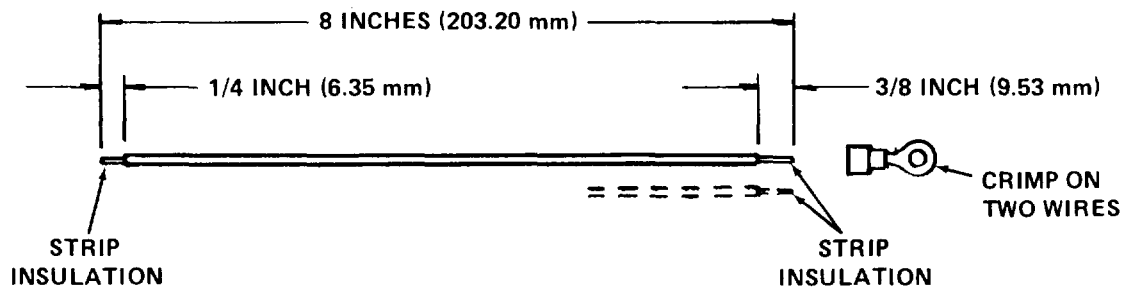

NOTES:

1. Fabricate from brown 16-gauge wire, per MI L-W-16878/I Type B.
2. Crimp terminal, part number 11275, on one end together with brown wire from control box harness plug.

Figure 1. Wire No. 10767.

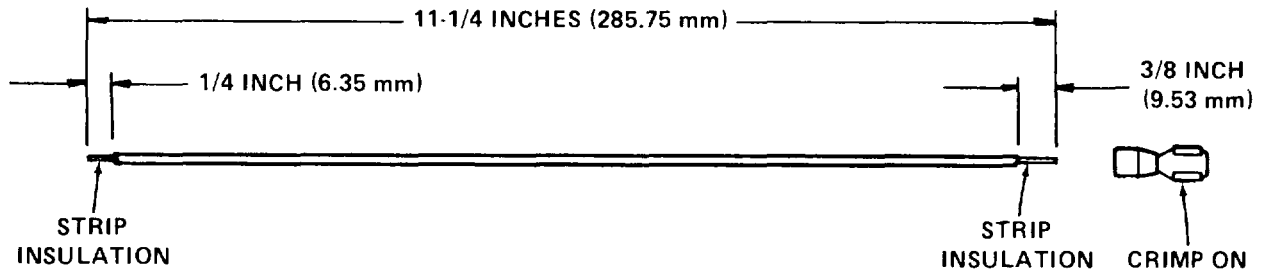

NOTES:

1. Fabricate from grey 20-gauge wire, per MIL-W-16878/1 Type B.
2. Crimp terminal, part number 5865, on one end.

Figure 2. Wire No. 10799.

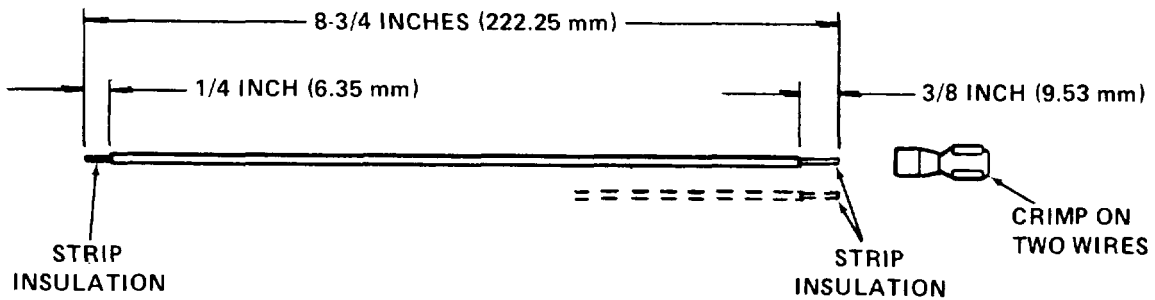

NOTES:

1. Fabricate from yellow 20-gauge wire, per MIL-W-16878/1 Type B.
2. Crimp terminal, part number 5865, on one end together with yellow wire from control harness plug.

Figure 3. Wire No. 10795.

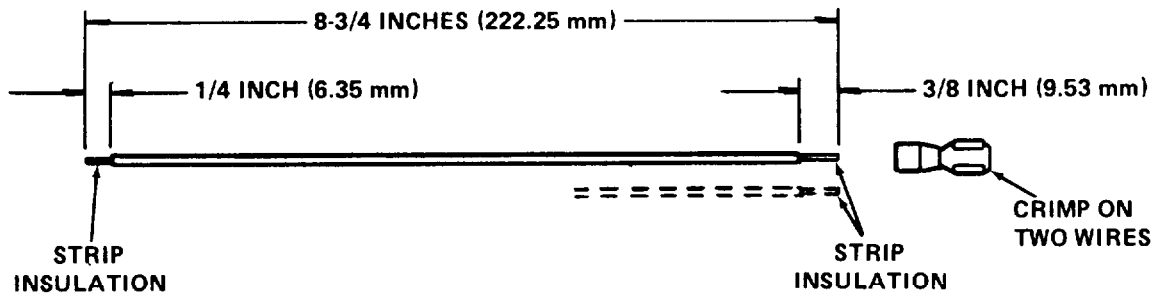

NOTES:

1. Fabricate from violet 20-gauge wire, per MIL-W-16878/1 Type 8.
2. Crimp terminal, part number 5865, on one end together with violet wire from room thermostat receptacle.

Figure 4. Wire No. 10739.

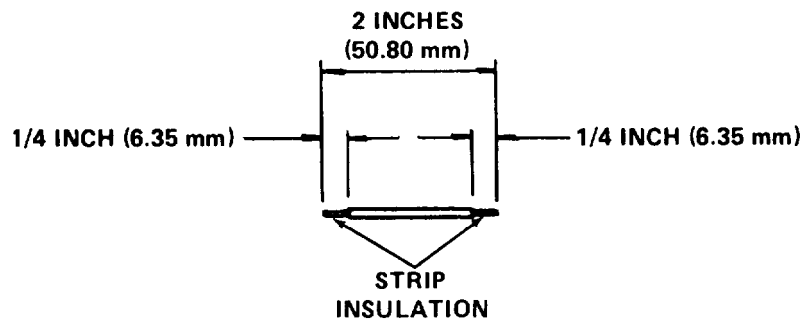

NOTE:

Fabricate from orange 20-gauge wire, per MIL-W-16878/1 Type B.

Figure 5. Wire No. 10736.

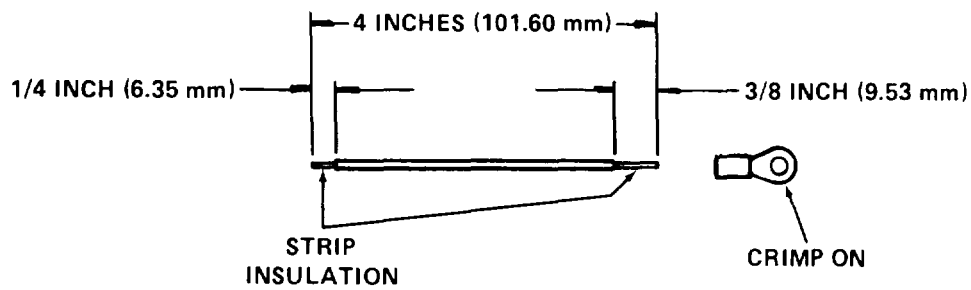

NOTES:

1. Fabricate from green 20-gauge wire, per MIL-W-16878/1 Type B.
2. Crimp terminal, part number 5383, on one end.

Figure 6. Wire No. 10768.

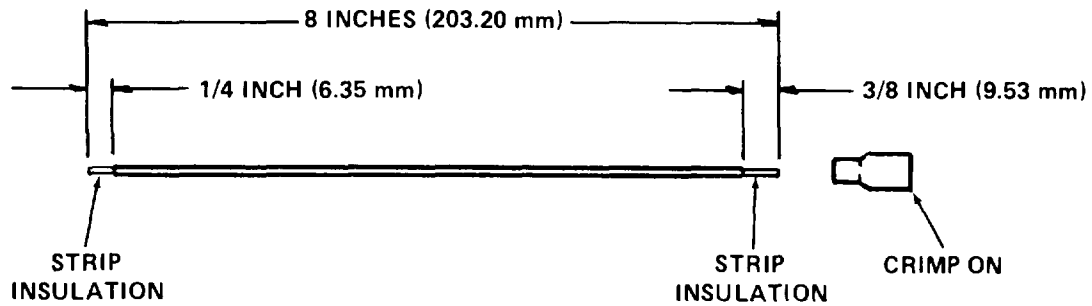

NOTES:

1. Fabricate from yellow 16-gauge wire, per MIL-W-16878/1 Type B.
2. Crimp terminal, part number 168547, on one end.

Figure 7. Wire No. 10781.

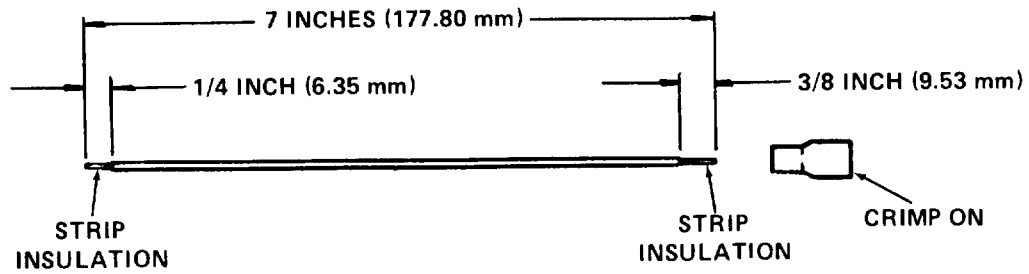

NOTES:

1. Fabricate from white 16-gauge wire, per MIL-W-16878/1 Type B.
2. Crimp terminal, part number 168547, on one end.

Figure 8. Wire No. 10770.

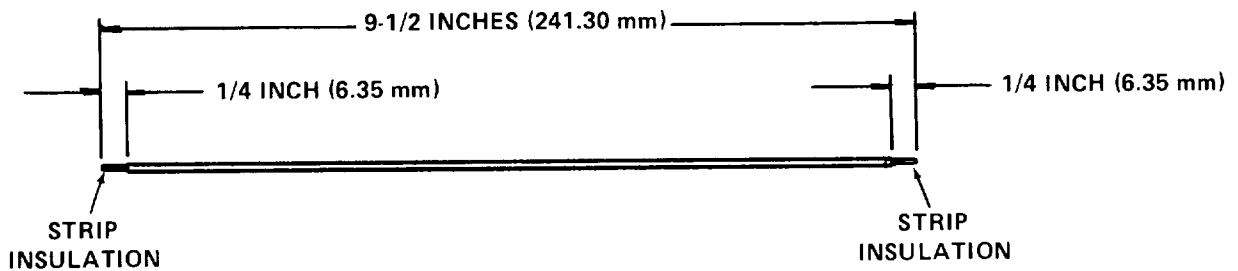

NOTE:

Fabricate from orange 16-gauge wire, per MIL-W-1 6878/1 Type B.

Figure 9. Wire No. 10766.

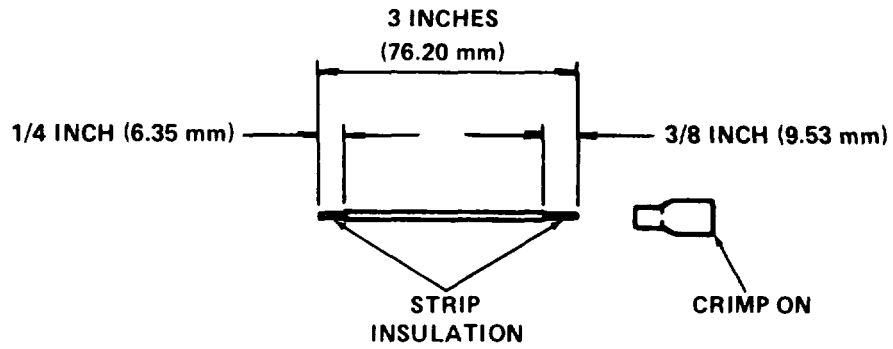

NOTES:

1. Fabricate from green 20-gauge wire, per MIL-W-16878/1 Type B.
2. Crimp terminal, part number 5383, on one end.

Figure 10. Wire No. 10785.

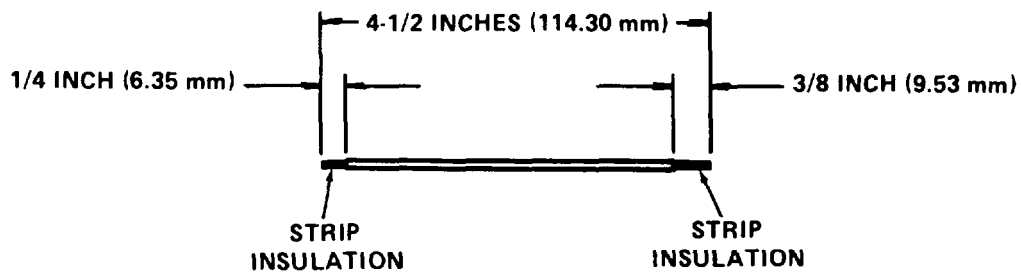

NOTE:

Fabricate from violet 20-gauge wire, per MIL-W-16878/1 Type B.

Figure 11. Wire No. 10739.

PART NUMBER INDEX

Part No.		Name/Location	Fig. No.
10736	Wire, orange	HEAT light to HEATER-OFF-FAN switch*	5
10739	Wire, violet	Room thermostat receptacle, terminal C to reset circuit breaker, terminal no. 1; 4-1/2 inches long	11
10739	Wire, violet	FAULT light to reset circuit breaker, terminal no. 1; 8-3/4 inches long	4
10766	Wire, orange	Room thermostat receptacle, terminal A, to HEATER-OFF-FAN switch*	9
10767	Wire, brown	Circuit breaker to HEATER-OFF-FAN switch*	1
10768	Wire, green	Fuel pump receptacle, terminal B, to ground	6
10768	Wire, green	Power receptacle, terminal D, to ground	6
10770	Wire, white	Combustion motor capacitor C2 to white wire of PC board**	8
10781	Wire, yellow	Combustion motor capacitor C1 to yellow wire of PC board**	7
10785	Wire, green	Room thermostat receptacle, terminal B, to ground	10
10795	Wire, yellow	FAULT light to reset circuit breaker, terminal no. 3	3
10799	Wire, grey	Reset circuit breaker, terminal no. 2, to HEATER-OFF-FAN switch*	2

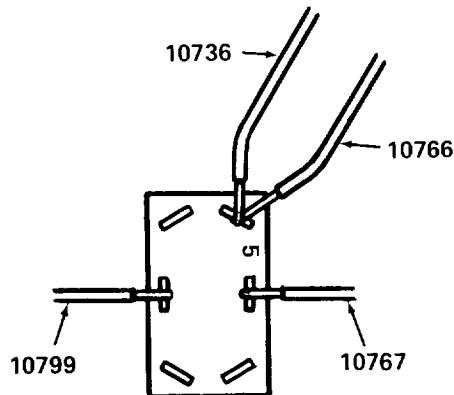

* Refer to illustration to locate correct terminal of HEATER-OFF-FAN switch.

** PC board has more than one each yellow and white wires. Always carefully tag wires when disconnecting.

**APPENDIX G
TORQUE LIMITS**

Section I. INTRODUCTION

G-1. SCOPE

This appendix lists standard torque values for self-locking nuts. Special torque values and sequences are indicated in the maintenance procedures for applicable components.

G-2. EXPLANATION OF LISTING

The listing relates thread size to minimum breakaway torque in inch pounds.

G-3. PROCEDURE

To determine breakaway torque, thread nut onto screw or bolt until at least two threads stick out. Nut shall not make contact with a mating part. Stop the nut. Torque necessary to begin turning nut again is the breakaway torque. Do not reuse self-locking nuts that do not meet minimum breakaway torque.

Section II. SELF-LOCKING NUT BREAKAWAY TORQUE VALUES

Thread Size	Minimum Breakaway Torque (In. Lb)	Thread Size	Minimum Breakaway Torque (In. Lb)
10-32	2.0	5/8-18	32.0
1 /4-28	3.5	3/4-16	50.0
5/16-24	6.5	7/8-14	70.0
3/8-24	9.5	1-12	90.0
7/16-20	14.0	1-1/8-12	117.0
1 /2-20	18.0	1-1/4-12	143.0
9/16-18	24.0		

GLOSSARY

Section I. ABBREVIATIONS

a c	Alternating current
Amp	Amperes
Btu/hr	British thermal units per hour
° C	Degree Celsius
CC	Cubic centimeter
cfm	Cubic foot per minute
cm	Centimeter
cu in	Cubic inch
cu m/s	Cubic meter per second
°	Degree
dc	Direct current
°F	Degree Fahrenheit
gal	Gallon
Hz	Hertz
in.	Inch
in. lb	Inch pound
kg	Kilogram
kPa	Kilopascal
lb	Pound
m	Meter
mm	Millimeter
N•m	Newton-meter
Pc	Printed circuit
PMCS	Preventive Maintenance Checks and Services
psi	Pounds per square inch
rpm	Revolutions per minute
V	Volt

Section II. DEFINITION OF UNUSUAL TERMS

A

ALIGN – To arrange in a line vertically and/or horizontally.

ALLOCATION – Assignment of duties or materials according to a plan.

AMBIENT – Surrounding. An engine cooled to ambient temperature has the same temperature as the air around it.

APPROVED – Permitted to be used for a specific purpose by the person or group who is authorized to grant approval.

ARC – A discharge of electric current crossing a gap between two electrodes.

ASSEMBLY – A combination of parts that may be taken apart without destruction, which has no application or use of its own but is needed for the completeness of a more complex item with which it is combined, or to which it is attached.

B

BINDING – Holding or restraining.

C

CARBON MONOXIDE – A poisonous gas that is made while a fuel is burning, especially if there is not quite enough air. The gas is colorless, odorless, and tasteless, but it can cause illness or death. See the warnings on the Warning page at front of manual.

COMBUSTION – A chemical change, especially oxidation, accompanied by the production of heat and light. A combustion engine functions by burning fuel to produce heat, i.e., energy.

COMPONENT – A part or a combination of parts which together accomplish a function.

COMPRESSED AIR – Air that is under pressure. When the compressed air in a hose or pipe is allowed to escape (such as when you use an air gun), the air moves very fast and is used to blow away dirt and chips for cleaning.

CONDENSATION – A liquid formed from a vapor. Moisture carried in warm air will condense when it reaches a cold area, such as the surface of a fuel tank in subzero weather.

CONTAMINATION – To make impure by contact or mixture.

CORROSION – A gradual wearing away caused by chemical action. Metals exposed to salt water are likely to corrode.

CRIMP – To bend or pinch together.

D

DEFECTIVE – Faulty; lacking perfection.

DEFICIENT – Lacking an essential element; incomplete.

DETERIORATE – A worsening of condition usually as a result of age or hostile environment, as opposed to mechanical damage.

E

EXHAUST – The gases that leave the engine through the tailpipe while the engine is running.

EXPENDABLE – An item that is not repairable and is discarded if damaged.

EXPOSURE – Being in the presence of something, or in contact with something. Skin is exposed to cleaning solvent when the solvent contacts the skin during cleaning operations.

F

FILTER – A device which removes dirt from the air or a fluid.

FLASH POINT – The lowest temperature at which the vapors of a solvent will ignite and burn.

FOULED – Spoiled; dirty; having an offensive odor.

FRAYED – Something which has been worn away or unravelled, usually by rubbing.

G

GASKET – A seal or packing used between matched machine parts or around pipe joints to prevent the escape of gas or fluid.

GOGGLES – A device used to protect the eyes from dust, dirt, flying chips, etc.

I

INITIAL – The first or starting condition.

INTERMITTENT – Stopping and starting at intervals.

M

MALFUNCTION – Occurs when a unit fails to operate normally.

MANUALLY – By hand; employing human rather than mechanical energy.

MANUFACTURER – The company which makes an item or piece of equipment for sale.

MATERIEL – Equipment, apparatus, and supplies of an organization such as an army.

O

OBSTRUCTION – An obstacle.

P

PIVOT – A short rod or shaft about which a related part rotates; the act of turning on or as if on a pivot.

POTTING – To embed with an insulating or protective material.

R

RECOMMENDATIONS – Suggestions for change; advice given usually to make an improvement.

REQUIRE – To demand or need.

S

SCOPE – The extent of an activity or concept; the amount of information covered as in a book.

SOLVENT – A liquid that can dissolve another substance.

T

TIEDOWN – Strap or fastening device used to hold an object in position.

TORQUE – Force around an axis. It produces a rotary or twisting motion, and is measured in foot pounds (ft lb) or newton-meters (N•m).

TOXIC – Harmful; deadly; poisonous.

V

VALVE – A device used to control the flow of a fluid.

VAPOR – The gaseous form of any substance which is usually a liquid; vapors are present in the air around the substance.

VENTILATE – To provide with a source of fresh or uncontaminated air.

W

WELD – A union or joint (of metals) produced by applying heat, sometimes with pressure.

ALPHABETICAL INDEX

Subject, Page

A

Additional Authorization List, D-1, D-2
 Additional Items Required, 3-5
 Adjustment
 of Heater, 3-9
 (See Specific items)
 Assembly
 (See Specific Items)
 Authorization List, Additional, D-1, D-2
 Auxiliary Equipment, Operation of, 2-5

B

Blower, Combustion, 3-100, 4-40
 Blower Motor, 4-47, 4-51
 Bottom Cover, 3-76
 Burner Head Assembly, 4-62, 4-65

C

Capabilities and Features, 1-3
 Capacitor, 4-46
 Ventilating Air Motor, 4-60
 Carburetor, 3-92
 Case Assembly, Heater, 3-66
 Case, Heater, 3-16, 4-33, 4-35
 Checks and Services, Preventive
 Maintenance, 3-10
 Circuit Breaker, 3-41
 Circuit Breaker, RESET, 3-43
 Combustion Blower, 3-100
 and Housing, 4-40
 Common Tools and Equipment, 3-2
 Control Box, 3-14, 3-37
 Harness Plug, 3-46
 Harness Wires, 3-51
 Wiring Harness, 3-45
 Controls, Operator, 2-1
 Cover
 Bottom, 3-76
 Side Heater Case, 3-123
 Cross-Reference List, Nomenclature, 1-2

Subject, Page

D

Data
 Equipment, 1-4
 Plates, 3-80
 Decals, 2-6
 Description of Major Components, 1-3
 Destruction of Army Materiel to Prevent
 Enemy Use, 1-2
 Disassembly
 of Heating System, 3-126
 (See Specific Items)
 Doors, 3-1
 and Bottom Cover, 3-76

E

Electrical Connections, External, 3-13
 Enemy Use, Destruction to Prevent, 1-2
 Equipment
 Auxiliary, Operation of, 2-5
 Common, 3-2
 Data, 1-4
 Improvement Recommendations, 1-2
 Inspection and Servicing Upon Receipt, 3-2
 Special, 3-2
 Unpacking, 3-2
 Exhaust System, 3-13
 External Electrical Connections, 3-13
 External Fuel Supply, 3-13
 Extreme Cold, Operation in, 2-10

F

Fan Mode, Operation in, 2-5
 Filter, Fuel, 3-89
 Fittings and Fuel Lines, 3-85
 Flame Switch and Bracket Assembly, 3-105
 Forms and Records, Maintenance, 1-1
 Fuel Filter, 3-89
 Fuel Line System, 3-12
 Fuel Lines and Fittings, 3-85
 Fuel Pump, 3-124
 Fuel Pump Receptacle, External, 3-60
 Fuel Supply, External, 3-13
 Fuel System, 3-18

Subject, Page

H

Harness Plug, Control Box, 3-46
 Harness Receptacle and Plug,
 PC Board Assembly, 4-26.1
 Harness Wires, Control Box, 3-51
 Harness, Wiring, Control Box, 3-45
 HEAT and FAULT Lights, 3-58
 Heat Exchanger, 4-67,4-72
 Heater, 3-20
 Adjustment, 3-9
 Location, 3-6
 Mounted Position of, 3-3
 Operation, 3-22
 Preliminary Servicing, 3-9
 Heater Case, 3-16,4-33,4-35
 Heater Case Assembly, 3-66
 HEATER-OFF-FAN Switch, 3-55
 Heater Operating Principles, 1-5
 Heating Mode, Operation in, 2-4
 High Altitudes, Operation at, 2-10
 Humid Conditions, Operation Under, 2-10

I

Igniter Assembly, 3-117
 Ignition Transformer and Cable, 3-110
 Indicators, Operator, 2-1
 Information Plates, 2-6
 Inspection
 of Equipment Upon Receipt, 3-2
 (See Specific Items)
 Installation
 Heater, 3-7
 (See Specific Items)
 Insulator, Shield, 4-37
 Intermediate Maintenance Instructions, 4-1
 Inverted Mounting, 3-4
 Items Required, Additional, 3-5

L

Labels, 3-84
 Left Side Mounting, 3-3
 Lights, HEAT and FAULT, 3-58
 Louver Linkage, 3-71
 Location of
 Heater, 3-6
 Major Components, 1-3
 Louvers, 3-1
 Lubrication Instructions, 3-1

Subject, Page

M

Maintenance Forms and Records, 1-1
 Maintenance Procedures, Unit, 3-36
 Motor
 Blower, 4-47,4-51
 Ventilating Air, 3-102,4-53,4-58
 Mounting of Heater
 Inverted, 3-4
 Left Side, 3-3
 Right Side, 3-4

N

Nomenclature Cross-Reference List, 1-2

O

Operating Instructions, 2-1
 operating Principles, Heater, 1-5
 Operating Procedures, 2-3
 Operation
 at High Altitudes, 2-10
 Heater, 3-22
 in Extreme Cold, Below 10°F (-12°C), 2-10
 in Fan Mode, 2-5
 in Heating Mode, 2-4
 of Auxiliary Equipment, 2-5
 Under Rainy or Humid Conditions, 2-10
 Under Unusual Conditions, 2-10
 Under Usual Conditions, 2-2
 Operator Controls and Indicators, 2-1

P

Packaging, 3-128
 Painted Surfaces, 4-39
 PC Board Assembly, 4-12, 4-26.4
 Harness Receptacle and Plug, 4-26.1
 Wiring Receptacle, 4-21
 Wiring Terminals, 4-24
 Plates
 Data, 3-80
 Information, 2-6
 Plugs, Room Thermostat, 3-124
 Power, Fuel Pump, and Room
 Thermostat Plugs, 3-124
 Power Receptacle and External Fuel
 Pump Receptacle, 3-60
 Preliminary Servicing of Heater, 3-9

Subject, Page

Preparation for Storage or Shipment, 1-2, 3-126
 Preventive Maintenance Checks and Services, 3-10
 Principles of Operation, 1-5
 Printed Circuit (PC) Board Assembly, 3-65
 Procedures, Maintenance, Unit, 3-36
 Procedures, Operating, 2-3
 Pump, Fuel 3-124
 Purpose of Heater, 1-2

R

Rainy Conditions, Operation Under, 2-10
 Receptacle
 Fuel Pump, External, 3-60
 Power, 3-60
 Room Thermostat, 3-39
 Records, Maintenance, 1-1
 Removal
 (See Specific Items)
 Repair
 (See Specific Items)
 Repair Parts, 3-2
 Reporting Equipment Improvement
 Recommendations, 1-2
 RESET Circuit Breaker, 3-43
 Right Side Mounting, 3-4
 Room Thermostat, 3-120
 Room Thermostat Plugs, 3-124
 Room Thermostat Receptacle, 3-39

S

Safety Thermostat, 3-105
 Scope, 1-1
 Servicing
 Equipment Upon Receipt, 3-2
 of Heater, Preliminary, 3-9
 (See Specific Items)
 Shield Insulator, 4-37
 Shields and Shield Insulator, 4-37
 Shipment, Preparation for, 1-2, 3-126

Subject, Page

Shutdown, 2-5
 Side Heater Case Covers, 3-123
 Side Panels and Louver Linkage, 3-71
 Solenoid, 3-97
 Storage, Preparation for, 1-2, 3-126
 Switch, HEATER-OFF-FAN, 3-55

T

Terminals, Wire, 3-49
 Test
 (See Specific Items)
 Thermal Motor Protector, 4-44
 Thermostat
 Room, 3-120
 Safety, 3-105
 Tools
 Common, 3-2
 Special, 3-2
 Transformer, Ignition, 3-110
 Troubleshooting
 Intermediate Maintenance, 4-1
 Unit Maintenance, 3-25

U

Unpacking Equipment, 3-2
 Unusual Conditions, Operation Under, 2-10
 Usual Conditions, Operation Under, 2-2

V

Ventilating Air Motor, 3-102, 4-53, 4-58
 Ventilating Air Motor Capacitor, 4-60

W

Wire Terminals, 3-49
 Wiring Harness, Control Box, 3-45
 Wiring Receptacle, PC Board Assembly, 4-21
 Wiring Terminals, PC Board Assembly, 4-24

By Order of the Secretary of the Army:

Official:

R. L. DILWORTH
Brigadier General, United States Army
The Adjutant General

JOHN A. WICKHAM, JR.
General, United States Army
Chief of Staff

DISTRIBUTION:

To be distributed in accordance with DA Form 12-25A, Operator's, Unit, and Intermediate Maintenance requirements for Heater, Space, Multifuel, 60,000 BTU (UH-68F).

RECOMMENDED CHANGES TO EQUIPMENT TECHNICAL PUBLICATIONS



THEN... JOT DOWN THE DOPE ABOUT IT ON THIS FORM. CAREFULLY TEAR IT OUT. FOLD IT AND DROP IT IN THE MAIL!

SOMETHING WRONG WITH THIS PUBLICATION?

FROM (PRINT YOUR UNIT'S COMPLETE ADDRESS)

PFC JOHN DOE
COA, 3d ENGINEER BN
FT. LEONARDWOOD, MA 63108

DATE SENT

PUBLICATION NUMBER

TM 5-4520-253-13

PUBLICATION DATE

4 Nov 86

PUBLICATION TITLE Heater, Space, Multi-fuel With Blower, 60,000 BTU/HR
120 V UH-68G

BE EXACT. PIN-POINT WHERE IT IS

PAGE NO	PARA-GRAPH	FIGURE NO	TABLE NO
6	2-1 a		
B1		4-3	
125	line 20		

IN THIS SPACE TELL WHAT IS WRONG AND WHAT SHOULD BE DONE ABOUT IT:

In line 6 of paragraph 2-1a the manual states the engine has 6 cylinders. The engine on my set only has 4 cylinders. Change the manual to show 4 cylinders.

Callout 16 on figure 4-3 is pointing at a bolt. In key to figure 4-3, item 16 is called a shim - Please correct one or the other.

I ordered a gasket, item 19 on figure B-16 by NSN 2 910-00-762-3001. I got a gasket but it doesn't fit. Supply says I got what I ordered, so the NSN is wrong. Please give me a good NSN

PRINTED NAME, GRADE OR TITLE AND TELEPHONE NUMBER

JOHN DOE, PFC (268) 317.7111

SIGN HERE

JOHN DOE

DA FORM 2028-2
1 JUL 79

PREVIOUS EDITIONS ARE OBSOLETE.

DRSTS-M Overprint 1, 1 Nov 80

PS--IF YOUR OUTFIT WANTS TO KNOW ABOUT YOUR RECOMMENDATION MAKE A CARBON COPY OF THIS AND GIVE IT TO YOUR HEADQUARTERS

TEAR ALONG PERFORATED LINE

The Metric System and Equivalents

Linear Measure

1 centimeter = 10 millimeters = .39 inch
 1 decimeter = 10 centimeters = 3.94 inches
 1 meter = 10 decimeters = 39.37 inches
 1 dekameter = 10 meters = 32.8 feet
 1 hectometer = 10 dekameters = 328.08 feet
 1 kilometer = 10 hectometers = 3,280.8 feet

Weights

1 centigram = 10 milligrams = .15 grain
 1 decigram = 10 centigrams = 1.54 grains
 1 gram = 10 decigram = .035 ounce
 1 dekagram = 10 grams = .35 ounce
 1 hectogram = 10 dekagrams = 3.52 ounces
 1 kilogram = 10 hectograms = 2.2 pounds
 1 quintal = 100 kilograms = 220.46 pounds
 1 metric ton = 10 quintals = 1.1 short tons

Liquid Measure

1 centiliter = 10 milliliters = .34 fl. ounce
 1 deciliter = 10 centiliters = 3.38 fl. ounces
 1 liter = 10 deciliters = 33.81 fl. ounces
 1 dekaliter = 10 liters = 2.64 gallons
 1 hectoliter = 10 dekaliters = 26.42 gallons
 1 kiloliter = 10 hectoliters = 264.18 gallons

Square Measure

1 sq. centimeter = 100 sq. millimeters = .155 sq. inch
 1 sq. decimeter = 100 sq. centimeters = 15.5 sq. inches
 1 sq. meter (centare) = 100 sq. decimeters = 10.76 sq. feet
 1 sq. dekameter (are) = 100 sq. meters = 1,076.4 sq. feet
 1 sq. hectometer (hectare) = 100 sq. dekameters = 2.47 acres
 1 sq. kilometer = 100 sq. hectometers = .386 sq. mile

Cubic Measure

1 cu. centimeter = 1000 cu. millimeters = .06 cu. inch
 1 cu. decimeter = 1000 cu. centimeters = 61.02 cu. inches
 1 cu. meter = 1000 cu. decimeters = 35.31 cu. feet

Approximate Conversion Factors

To change	To	Multiply by	To change	To	Multiply by
inches	centimeters	2.540	ounce-inches	newton-meters	.007062
feet	meters	.305	centimeters	inches	.394
yards	meters	.914	meters	feet	3.280
miles	kilometers	1.609	meters	yards	1.094
square inches	square centimeters	6.451	kilometers	miles	.621
square feet	square meters	.093	square centimeters	square inches	.155
square yards	square meters	.836	square meters	square feet	10.764
square miles	square kilometers	2.590	square meters	square yards	1.196
acres	square hectometers	.405	square kilometers	square miles	.386
cubic feet	cubic meters	.028	square hectometers	acres	2.471
cubic yards	cubic meters	.765	cubic meters	cubic feet	35.315
fluid ounces	milliliters	29.573	cubic meters	cubic yards	1.308
pints	liters	.473	milliliters	fluid ounces	.034
quarts	liters	.946	liters	pints	2.113
gallons	liters	3.785	liters	quarts	1.057
ounces	grams	28.349	liters	gallons	.264
pounds	kilograms	.454	grams	ounces	.035
short tons	metric tons	.907	kilograms	pounds	2.205
pound-feet	newton-meters	1.356	metric tons	short tons	1.102
pound-inches	newton-meters	.11296			

Temperature (Exact)

°F	Fahrenheit temperature	5/9 (after subtracting 32)	Celsius temperature	°C
----	------------------------	----------------------------	---------------------	----

PIN: 060655-002

TECHNICAL MANUAL

**UNIT AND DIRECT SUPPORT MAINTENANCE
REPAIR PARTS AND SPECIAL TOOLS LIST
FOR**

**HEATER, SPACE, MULTIFUEL
WITH BLOWER, 60,000 BTU/HR, 120V
MODEL UH-68G, NSN 4520-01-203-4410
AND MODEL UH-68GI,
NSN 4520-01-297-6803**

Approved for public release; Distribution is unlimited,

*This manual supersedes TM 5-4520-253-23P, 18 June 1987, including all changes.

**HEADQUARTERS, DEPARTMENT OF THE ARMY
10 JULY 1990**

**UNIT AND DIRECT SUPPORT MAINTENANCE
REPAIR PARTS AND SPECIAL TOOLS LIST
FOR
HEATER, SPACE, MULTIFUEL
WITH BLOWER, 60,000 BTU/HR, 120V
MODEL UH-68G, NSN 4520-01-203-4410
AND MODEL UH-68GI,
NSN 4520-01-297-6803**

Current as of 7 December 1989

Approved for public release. Distribution is unlimited.

REPORTING ERRORS AND RECOMMENDING IMPROVEMENTS
You can help improve this manual. If you find any mistakes or if you know of a way to improve the procedures, please let us know. Mail your letter, DA Form 2028 (Recommended Changes to Publications and Blank Forms), or DA Form 2028-2 located in back of this manual direct to: AMSTR-MCTS, 4300 Goodfellow Boulevard, St. Louis, MO 63120-1798. A reply will be furnished to you.

TABLE OF CONTENTS

		Page	Illus Figure
Section	1. INTRODUCTION	1	
	II. REPAIR PARTS LIST	1-1	
Group	01 Control Box Assembly	1-1	
	Control Box and P. C. Board Assemblies	1-1	1
	P, C. Board Assembly, Model UH-68G	2-1	2
	P. C. Board Assembly, Model UH-68G1	3-1	3
	Control Box Assembly	4-1	4
	Control Box Harness Assembly	5-1	5
Group	02 Heater Case Assembly	6-1	
	Side Panels and Louver Linkage.. . . .	6-1	6
	Right Hand Louver Panel Assembly	7-1	7
	Left Hand Louver Panel Assembly	8-1	8
	Heater Case Assembly	9-1	9

*This manual supersedes TM5-4520-253-23P, 18 June 1987, including all changes.

TABLE OF CONTENTS (Continued)

			Page	Illus. Figure
Group	03	Fuel System	10-1	
		Carburetor and Fittings	10-1	10
		Fuel Filter Assembly	11-1	11
		Carburetor Assembly	12-1	12
Group	04	Electrical	13-1	
		Thermostat and Flame Switch Assemblies	13-1	13
		Combustion Blower and Housing	14-1	14
		Blower Motor Subassembly	15-1	15
		Ventilating Air Motor	16-1	16
Group	05	Burner Assembly	17-1	
		Burner Head and Transformer	17-1	17
Group	06	Heat Exchanger	18-1	
		Heat Exchanger and Shields	18-1	18
Group	07	Accessory Items	19-1	
		Accessories,	19-1	19
Group	08	Bulk	Bulk-1	
Section	III.	SPECIAL TOOLS LIST (Nonapplicable)		
Section	IV.	CROSS REFERENCE INDEX		
		NATIONAL STOCK NUMBER INDEX	I-1	
		PART NUMBER INDEX	I-4	
		FIGURE AND ITEM NUMBER INDEX	I-13	

UNIT AND DIRECT SUPPORT MAINTENANCE
REPAIR PARTS AND SPECIAL TOOLS LIST

SECTION I. INTRODUCTION

1. SCOPE. This RPSTL lists and authorizes spares and repair parts; special tools; special test, measurement, and diagnostic equipment (TMDE); and other special support equipment required for performance of Unit and Direct Support Maintenance of the Space Heater. It authorizes the requisitioning, issue, and disposition of spares, repair parts and special tools as indicated by the source, maintenance and recoverability (SMR) codes.

2. GENERAL. In addition to this section, Introduction, this Repair Parts and Special Tools List is divided into the following sections:

a. Section II. Repair Parts List. A list of spares and repair parts authorized by this RPSTL for use in the performance of maintenance. The list also includes parts which must be removed for replacement of the authorized parts. Parts lists are composed of functional groups in ascending alphanumeric sequence with the parts in each group listed in ascending figure and item number sequence. Bulk materials are listed in item name sequence. Repair parts kits are listed separately in their own functional group within Section II. Repair parts for repairable special tools are also listed in this section. Items listed are shown on the associated illustration(s) /figure(s).

b. Section III. Special Tools List. A list of special tools, special TMDE, and other special support equipment authorized by this RPSTL (as indicated by Basis of Issue (BOI) information in DESCRIPTION AND USABLE ON CODE column) for the performance of maintenance.

c. Section IV. Cross-references Indexes. A list, in National Item Identification Number (NIIN) sequence, of all National stock numbered items appearing in the listing, followed by a list in alphanumeric sequence of all part numbers appearing in the listings. National stock numbers and part numbers are cross referenced to each illustration figure and item number appearance. The figure and item number index lists figure and item number in alphanumeric sequence and cross references NSN, FSCM and part number.

3. EXPLANATION OF COLUMNS (SECTIONS II AND III).

a. ITEM NO. (Column (1)). Indicates the number used to identify items called out in the illustration

b. SMR Code (Column (2)). The Source, Maintenance, and Recoverability (SMR) code is a 5-position code containing supply/requisitioning information, maintenance category authorization criteria, and disposition instruction, as shown in the following breakout:

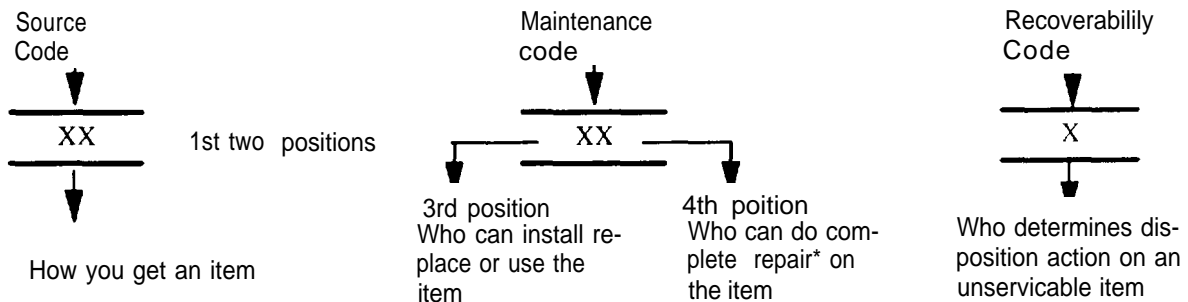

NOTE

*Complete Repair: Maintenance capacity, capability, and authority to perform all corrective maintenance tasks of the "Repair" function in a use/user environment in order to restore serviceability to a failed item

(1) Source Code. The source code tells you how to get an item needed for maintenance, repair, or overhaul of an end item/equipment. Explanations of source codes follows:

Code	Explanation
PA	
PB	
PC**	
PD	
PE	Stocked items; use the applicable NSN to request/requisition items with these source codes. They are authorized to the category indicated by the code entered in the 3d position of the SMR code.
PF	
PG	
<hr/>	
KD	**NOTE: Items coded PC are subject to deterioration.
KF	
KB	Items with these codes are not to be requested/requisitioned individually. They are part of a kit which is authorized to the maintenance category indicated in the 3d position of the SMR code. The complete kit must be requisitioned and applied.
<hr/>	
	Explanation
MO-(Made at org. AVUM Level	
MF-(Made at DS/ AVUM Level	Items with these codes are not to be requested/requisitioned individually. They must be made from bulk material which is identified by the part number in the DESCRIPTION and US-ABLE ON CODE (UOC) column and listed in the Bulk Material group of the repair parts list in this RPSTL. If the item is authorized to you by the 3d position code of the SMR code, but the source code indicates it is made at a higher level, order the item from the higher level of maintenance.
MH-(Made at GS Level)	
ML—Made at Specialized Repair Activity (SRA))	
MD-(Made at Depot)	

	Explanation
AO -- (Assembled by org/AVUM Level) AF -- (Assembled by DS/AVIM Level) AH -- (Assembled by GS Category) AL -- (Assembled by SRA) AD -- (Assembled by Depot)	Items with these codes are not to be requested/requisitioned individually, The parts that make up the assembled item must be requisitioned or fabricated and assembled at the level of maintenance indicated by the source code. If the 3d position code of the SMR code authorizes you to replace the item, but the source code indicates the items are assembled at a higher level, order the item from the higher level of maintenance.

Code	Explanation
XA --	Do not requisition "XA" -coded item. Order its next higher assembly. (Also, refer to the NOTE below,)
XB --	If an "XB" item is not available from salvage, order it using the FSCM and part number given.
XC --	Installation drawing, diagram, instruction sheet, field service drawing, that is identified by manufacturer's part number,
XD --	Item is not stocked, Order an "XD" -coded item through normal supply channels using the FSCM and part number given, if no NSN is available.

NOTE

Cannibalization or controlled exchange, when authorized, may be used as a source of supply for items with the above source codes, except for those source coded "XA" or those aircraft support items restricted by requirements of AR 750-1.

- (2) Maintenance Code. Maintenance codes tells you the level(s) of maintenance authorized to USE and REPAIR support items. The maintenance codes are entered in the third and fourth positions of the SMR code as follows:
 - (a) The maintenance code entered in the third position tells you the lowest maintenance level authorized to remove, replace, and use an item. The maintenance code entered in the third position will indicate authorization to one of the following levels of maintenance.

Code	Application/Explanation
C	-Crew or operator maintenance done within organizational or aviation unit maintenance,
O	-Organizational or aviation unit category can remove, replace, and use the item.

F -Direct support or aviation intermediate level can remove, replace, and use the item.

H -General support level can remove, replace, and use the item

L -Specialized repair activity can remove, replace, and use the item.

D -Depot level can remove, replace, and use the item.

- (b) The maintenance code entered in the fourth position tells whether or not the item is to be repaired and identifies the lowest maintenance level with the capability to do complete repair (i.e. , perform all authorized repair functions.) NOTE: Some limited repair may be done on the item at a lower level of maintenance, if authorized by the Maintenance Allocation Chart (MAC) and SMR codes. This position will contain one of the following maintenance codes.

Code	Application/Explanation
O	Organizational or (aviation unit) is the lowest level that can do complete repair of the item.
F	-Direct support or aviation intermediate is the lowest level that can do complete repair of the item.
H	-General Support is the lowest level that can do complete repair of the item.
L	-Specialized repair activity is the lowest level that can do complete repair of the item.
D	-Depot is the lowest level that can do complete repair of the item.
Z	-Nonreparable. No repair is authorized.
B	-No repair is authorized. (No parts or special tools are authorized for the maintenance of a "B" coded item). However, the item may be reconditioned by adjusting, lubricating, etc., at the user level.

- (3) Recoverability Code, Recoverability codes are assigned to items to indicate the disposition action on unserviceable items. The recoverability code is entered in the fifth position of the SMR Code as follows:

Recoverability Codes	Application/Explanation
Z	-Nonreparable item. When unserviceable, condemn and dispose of the item at the level of maintenance shown in 3d position of SMR Code.

Recoverability

Codes	Application/Explanation
-------	-------------------------

- | | |
|---|---|
| O | —Reparable item. When uneconomically reparable, condemn and dispose of the item at organizational or aviation unit level |
| F | —Reparable item. When uneconomically reparable, condemn and dispose of the item at the direct support or aviation intermediate level |
| H | —Reparable item. When uneconomically reparable, condemn and dispose of the item at the general support level. |
| D | —Reparable item. When beyond lower level repair capability, return to depot. Condemnation and disposal of item not authorized below depot level |
| L | —Reparable item. Condemnation and disposal not authorized below specialized repair activity (SRA). |
| A | —Item requires special handling or condemnation procedures because of specific reasons (e.g. , precious metal content, high dollar value, critical material, or hazardous material). Refer to appropriate manuals/directives for specific instructions. |

c. FSCM (Column (3)). The Federal Supply Code for Manufacturer (FSCM) is a 5-digit numeric code which is used to identify the manufacturer, distributor, or Government agency, etc., that supplies the item

d. PART NUMBER (Column (4)). Indicates the primary number used by the manufacturer, (individual, company, firm, corporation, or Government activity), which controls the design and characteristics of the item by means of its engineering drawings, specifications standards, and inspection requirements to identify an item or range of items.

NOTE

When you use an NSN to requisition an item, the item you receive may have a different part number from the part ordered.

e. DESCRIPTION AND USABLE ON CODE (UOC) (Column (5)). This column includes the following information:

- (1) The Federal item name and, when required, a minimum description to identify the item.
- (2) The physical security classification of the item is indicated by the parenthetical entry, e.g , Phy Sec CI - Confidential, Phy Sec CI (S) - Secret, Phy Sec CI (T) – Top Secret.
- (3) Items that are included in kits and sets are listed below the name of the kit or set.
- (4) Spare/repair parts that make up an assembled item are listed immediately following the assembled item line entry,
- (5) Part numbers for bulk materials are referenced in this column in the line item entry for the item to be manufactured/fabricated.
- (6) When the item is not used with all serial numbers of the same model, the effective serial numbers are shown on the last line(s) of the description (before UOC).

- (7) The usable encode, when applicable (see paragraph 5, Special information).
- (8) In the Special Tools List section, the basis of issue (BOI) appears as the last line(s) in the entry for each special tool, special TM DE, and other special support equipment. When density of equipments supported exceeds density spread indicated in the basis of issue, the total authorization is increased proportionately.
- (9) The statement "END OF FIGURE" appears just below the last item description in Column 5 for a given figure in both Section II and Section III.
- (10) The indenture, shown as dots appearing before the repair part, indicates that the item is a repair part of the next higher assembly.

f. QTY (Column (6)). The QTY (quantity per figure column) indicates the quantity of the item used in the breakout shown on the illustration figure, which is prepared for a functional group, subfunctional group, or an assembly. A "V" appearing in this column in lieu of a quantity indicates that the quantity is variable and may vary from application to application.

4. EXPLANATION OF COLUMNS (SECTION IV).

a. NATIONAL STOCK NUMBER (NSN) INDEX.

- (1) STOCK NUMBER column. This column lists the NSN by National item identification number (NIIN) sequence. The NIIN consists of the last nine digits of the NSN
NSN, i.e. (5305-01-574-1 467),
NIIN

When using this column to locate an item, ignore the first 4 digits of the NSN.
However, the complete NSN should be used when ordering items by stock number

- (2) FIG. column. This column lists the number of the figure where the item is identified/located
The figures are in numerical order in Section II and Section III.
- (3) ITEM column. The item number identifies the item associated with the figure listed in the adjacent FIG. column. This item is also identified by the NSN listed on the same line.

b. PART NUMBER INDEX. Part numbers in this index are listed by part number in ascending alphanumeric sequence (i e. , vertical arrangement of letter and number combination which places the first letter or digit of each group in order A through Z, followed by the numbers 0 through 9 and each following letter or digit in like order).

- (1) FSCM column. The Federal Supply Code for Manufacturer (FSCM) is a 5-digit numeric code used to identify the manufacturer, distributor, or Government agency, etc. , that supplies the item.
- (2) PART NUMBER column. Indicates the primary number used by the manufacturer (individual firm, corporation, or Government activity), which controls the design and characteristics of the item by means of its engineering drawings, specifications standards, and inspection requirements to identify an item or range of items.
- (3) STOCK NUMBER column. This column lists the NSN for the associated part number and manufacturer identified in the PART NUMBER and FSCM columns to the left.

- (4) FIG. column. This column lists the number of the figure where the item is identified/located in Sections II and III.
- (5) ITEM column. The item number is that number assigned to the item as it appears in the figure referenced in adjacent figure number column.

c. FIGURE AND ITEM NUMBER INDEX.

- (1) FIG. column. This column lists the number of the figure where the item is identified/located in Section II and III.
- (2) ITEM column. The item number is that number assigned to the item as it appears in the figure referenced in the adjacent figure number column.
- (3) STOCK NUMBER column. This column lists the NSN for the item.
- (4) FSCM column. The Federal Supply Code for Manufacturer (FSCM) is a 5-digit numeric code used to identify the manufacturer, distributor, or Government agency, etc., that supplies the item.
- (5) PART NUMBER column. Indicates the primary number used by the manufacturer (individual, firm, corporation, or Government activity), which controls the design and characteristics of the item by means of its engineering drawings, specifications standards, and inspection requirements to identify an item or range of items.

5. SPECIAL INFORMATION.

a. USABLE ON CODE. The usable on code appears in the lower left corner of the Description column heading. Usable on codes are shown as "UOC:" in the Description Column (justified left) on the last line applicable item description/nomenclature. Uncoded items are applicable to all models.

CODE	USED ON
DYS	Model UH-68G
ETG	Model UH-68G1

b. ASSOCIATED PUBLICATIONS. The publications listed below pertains to the Space Heater and it's components.

Publication	Short Title
TM 5-4520-253-13	Space Heater

6. HOW TO LOCATE REPAIR PARTS.

a. When National Stock Number or Part Number is NOT known.

- (1) First. Using the table of contents, determine the assembly group or subassembly group 10 which the item belongs, This is necessary since figures are prepared for assembly groups and subassembly groups, and listings are divided into the same groups.
- (2) Second. Find the figure covering the assembly group or subassembly group to which the item belongs.

(3) Third. Identify the item on the figure and note the item number.

(4) Fourth. Refer to the Repair Parts List for the figure to find the part number for the item number noted on the figure.

(5) Fifth. Refer to the Part Number Index to find the NSN, if assigned.

b. When National Stock Number or Part Number is Known:

(1) First. Using the Index of National Stock Numbers and Part Numbers, find the pertinent National Stock Number or Part Number. The NSN index is in National Item Identification Number (NIIN) sequence (see c-4a,(1)), The part numbers in the Part Number index are listed in ascending alphanumeric sequence (see c-4.b). Both indexes cross-reference you to the illustration figure and item number of the item you are looking for

(2) Second. After finding the figure and item number, verify that the item is the one you are looking for, then locate the item number in the repair parts list for the figure.

7. Abbreviations. Abbreviations used in this manual are listed in MIL-STD-12

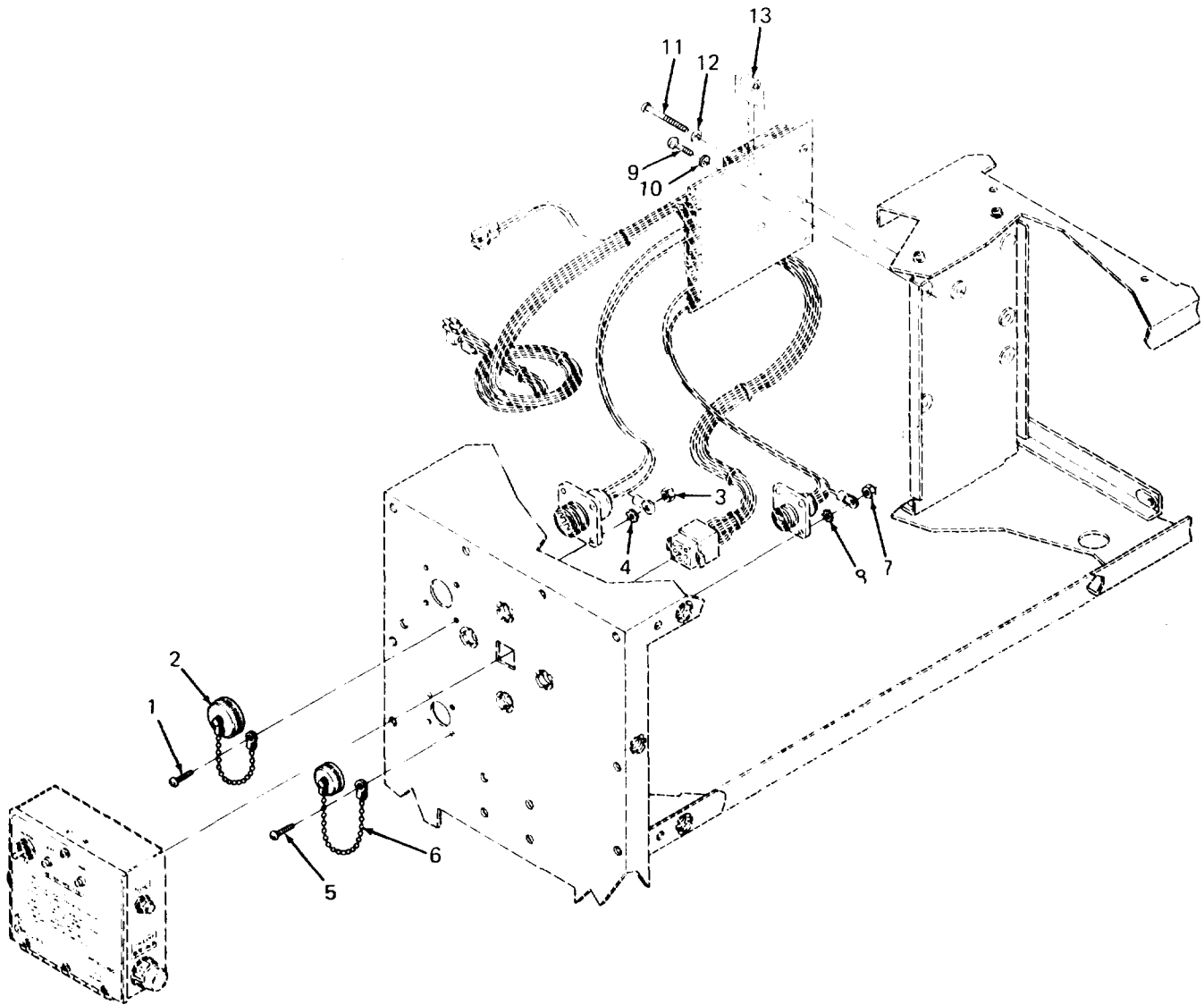

Figure 1. Control Box and P.C. Board Assemblies

SECTION II (1)	ITEM (2)	(3)	TM5-4520-253-23P (4)	(5)	(6)
NO	SMR CODE	FSCM	PART NUMBER	DESCRIPTION AND USABLE ON CODE (UOC)	QTY
GROUP 01 CONTROL BOX ASSEMBLY					
FIG. 1 CONTROL BOX AND P.C. BOARD ASSEMBLIES					
1	PAOZZ	96906	MS35206-215	SCREW,MACHINE ROUND HEAD,#4-40 X 3/ 8 IN. LG	4
2	PAOZZ	96906	MS25043-18DA	COVER,ELECTRICAL CO.	1
3	PAOZH	96906	MS35649-242	NUT,PLAIN,HEXAGON #4-40	4
4	PAOZZ	96906	MS35335-29	WASHER,LOCK EXTERNAL TOOTH,#A4	4
5	PAOZZ	96906	MS35206-215	SCREW,MACHINE ROUND HEAD,#4-40 X 3/ 8 IN. LG.	4
6	PAOZZ	96906	MS25043-14DA	COVER,ELECTRICAL CO	1
7	PAOZH	96906	MS35649-242	NUT,PLAIN,HEXAGON #4-40	4
8	PAOZZ	96906	MS35335-29	WASHER,LOCK EXTERNAL TOOTH,#4	4
9	PAOZZ	96906	MS35206-227	SCREW,MACHINE PAN HEAD	4
10	PAOZZ	96906	MS35333-37	WASHER,LOCK INTERNAL TOOTH	4
11	PAOZZ	96906	MS35206-231	SCREW,MACHINE ROUND HEAD,#6-32 X 1.75 IN. LG.	2
12	PAOZZ	96906	MS35333-37	WASHER,LOCK INTERNAL TOOTH	2
13	XBOZZ	92878	168227	SPACER	2

END OF FIGURE

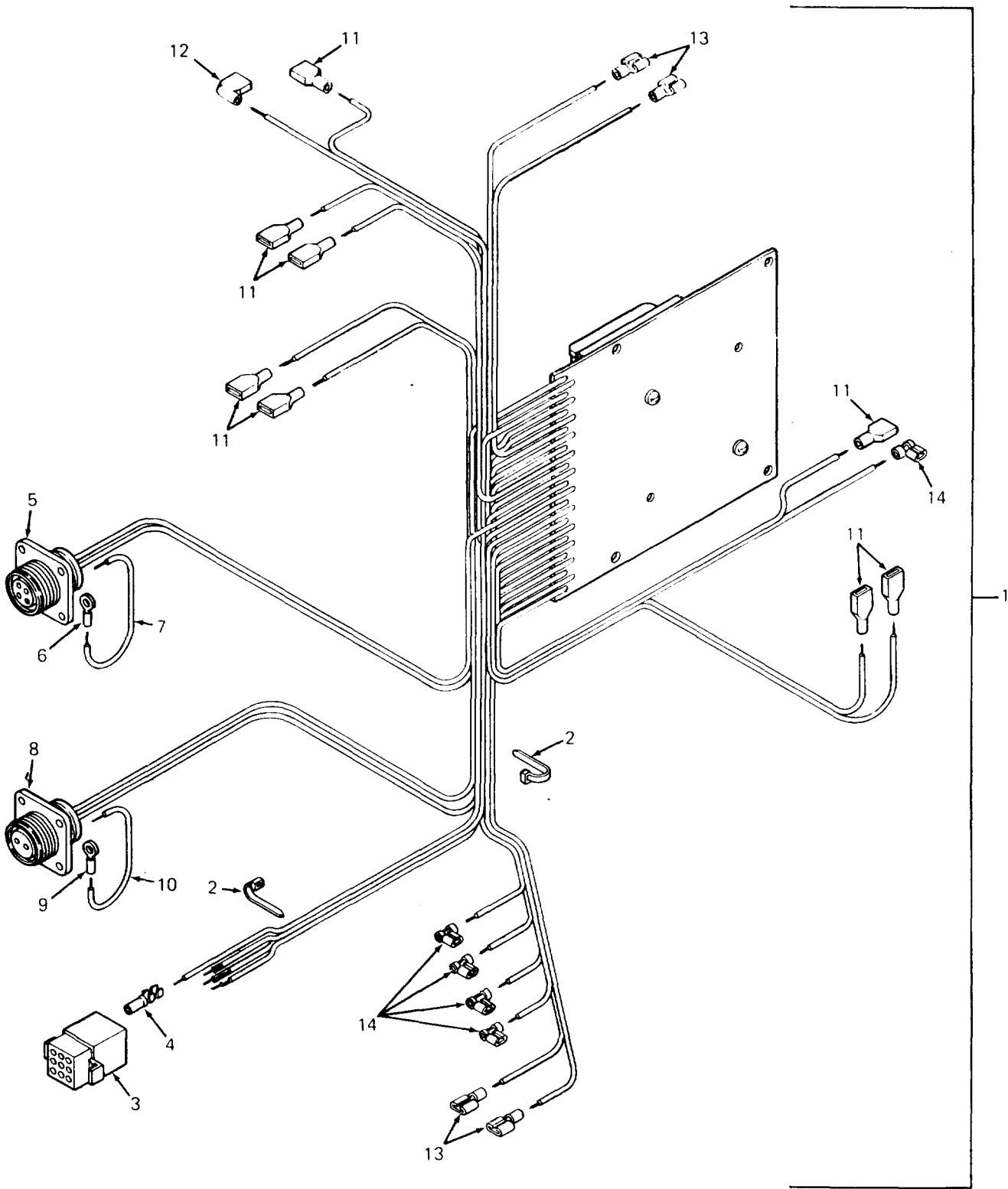

Figure 2. P.C. Board Assembly, Model UH-68G

SECTION II (1) ITEM NO	(2) SMR CODE	(3) FSCM	TM5-4520-253-23P (4) PART NUMBER	(5) DESCRIPTION AND USABLE ON CODE (UOC)	(6) QTY
GROUP 01 CONTROL BOX ASSEMBLY					
FIG. 2 P.C. BOARD ASSEMBLY, MODEL UH-68G					
1	PBFFZ	92878	168257	PRINTED CIRCUIT BOA UOC:DYS	1
2	PAOZZ	96906	MS3367-1-9	STRAP, TIEDOWN, ELECT UOC:DYS	15
3	XDFZZ	13499	372-5909-720	CONNECTOR, RECEPTACL CONTROL BOX UOC:DYS	1
4	XBFZZ	237264	1189-02-09-1103	TERMINAL UOC:DYS	8
5	PAFZA	96906	MS3103-14S-9S	CONNECTOR, RECEPTACL PUMP UOC:DYS	1
6	PAFZF	96906	MS25036-102	TERMINAL, LUG TONGUE, INSULATED, 16-14 AWG UOC:DYS	1
7	MFFZZ	92878	10768-12	WIRE, ELECTRICAL, 16 GA., GREEN, 4 IN. LG. MFR. FROM P/N MM3412 (99974) UOC:DYS	1
8	PAFZA	96906	MS3103-18-10P	CONNECTOR, RECEPTACL UOC:DYS	1
9	PAFZF	96906	MS25036-102	TERMINAL, LUG TONGUE, INSULATED, 16-14 AWG UOC:DYS	1
10	MFFZZ	92878	10768-12	WIRE, ELECTRICAL 16 GA., GREEN, R IN. LG. MFR. FROM P/N MM3412 (99974) UOC:DYS	1
11	XDFZZ	14726	SO5075	CONNECTOR, PLUG, ELEC NYLON, FULLY INSULATED, 16-14 AWG UOC:DYS	8
12	PAFZZ	14726	SO5363SFT	TERMINAL, QUICK DISC FULLY INSULATED, FEMALE, QUICK DISCONNECT, 16-14 AWG UOC:DYS	1
13	PAFZZ	14726	SO9718SF	TERMINAL, QUICK DISC DISCONNECT, FEMALE, 16-14 AWG UOC:DYS	4
14	PAFZZ	59730	B14-250A	TERMINAL, QUICK DISC UOC:DYS	5

END OF FIGURE

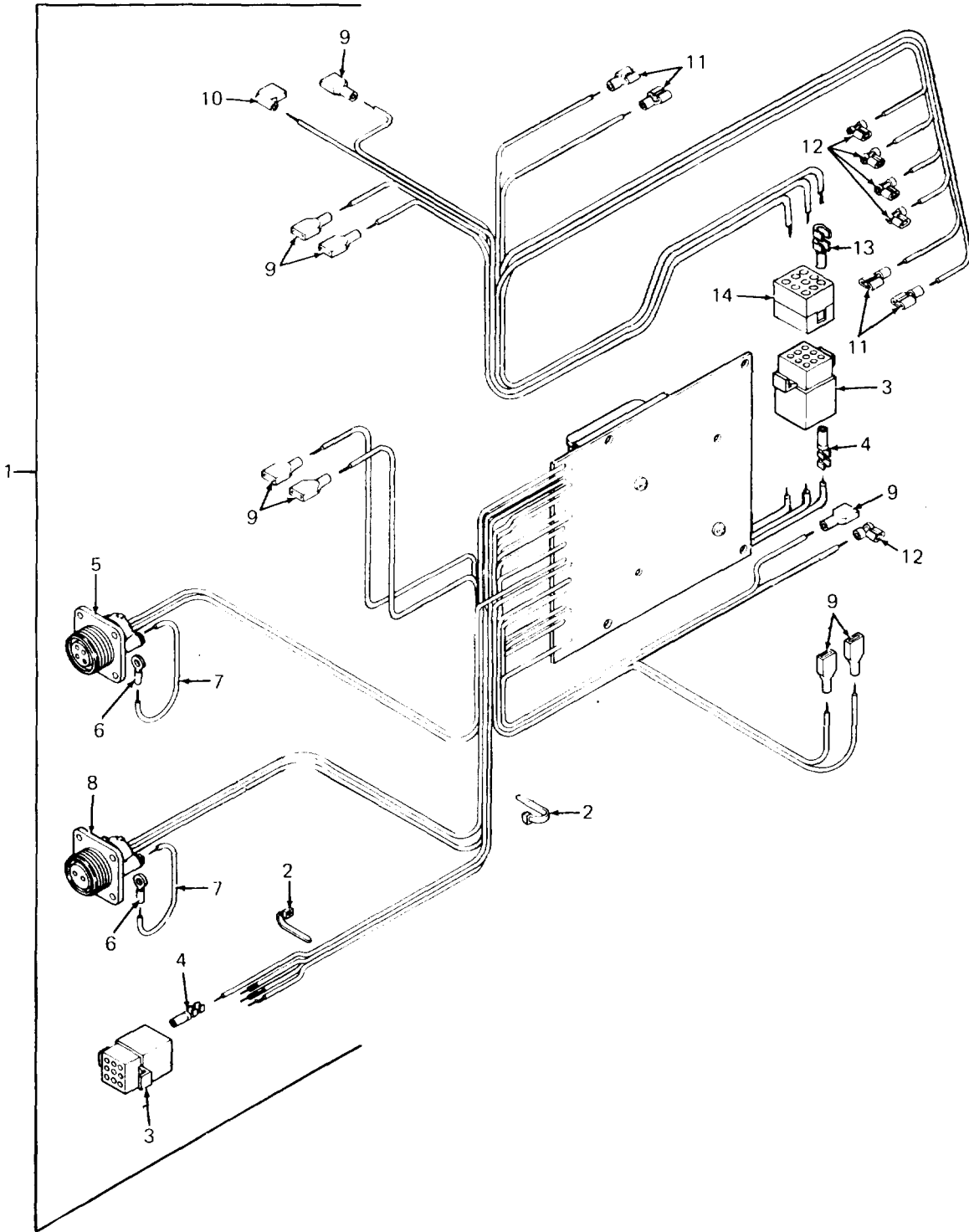

Figure 3. P.C. Board Assembly, Model UH-68G1

SECTION II (1) ITEM NO	(2) SMR CODE	(3) FSCM	TM5-4520-253-23P (4) PART NUMBER	(5) DESCRIPTION AND USABLE ON CODE (UOC)	(6) QTY
GROUP 01 CONTROL BOX ASSEMBLY					
FIG. 3 P.C. BOARD ASSEMBLY, MODEL UH-68G1					
1	PBFFZ	92878	16825701	PRINTED CIRCUIT BOA UOC:ETG	1
2	PAOZZ	96906	MS3367-1-9	STRAP, TIEDOWN, ELECT UOC:ETG	15
3	XDFZZ	13499	372-5909-720	CONNECTOR, RECEPTACL CONTROL BOX UOC:ETG	1
4	XBFZZ	27264	1189-02-09-1103	TERMINAL UOC:ETG	8
5	PAFZZ	96906	MS3100R-14S-9S	CONNECTOR, RECEPTACL PUMP UOC:ETG	1
6	PAFZF	96906	MS25036-102	TERMINAL, LUG TONGUE, INSULATED, 16-14 AWG UOC:ETG	1
7	MFFZZ	92878	10768-12	WIRE, ELECTRICAL, 16 GA., GREEN, 4 IN. LG. MFR FROM P/N MM3412 (99974) UOC:ETG	1
8	PAFZZ	96906	MS3450W18-10P	CONNECTOR, RECEPTACL UOC:ETG	1
9	XDFZZ	14726	SO5075	CONNECTOR, PLUG, ELEC NYLON, FULLY INSULATED, 16-14 AWG UOC:ETG	8
10	PAFZZ	14726	SO5363SFT	TERMINAL, QUICK DISC FULLY INSULATED, FEMALE, QUICK DISCONNECT, 16-14 AWG UOC:ETG	1
11	PAFZZ	14726	S09718SF	TERMINAL, QUICK DISC DISCONNECT, FEMALE, 16-14 AWG UOC:ETG	4
12	PAFZZ	59730	B14-250A	TERMINAL, QUICK DISC UOC:ETG	5
13	XBFZZ	27264	1190-02-09-2103	TERMINAL UOC:ETG	8
14	XBOZZ	27264	03-09-2092	PLUG UOC:ETG	1
END OF FIGURE					

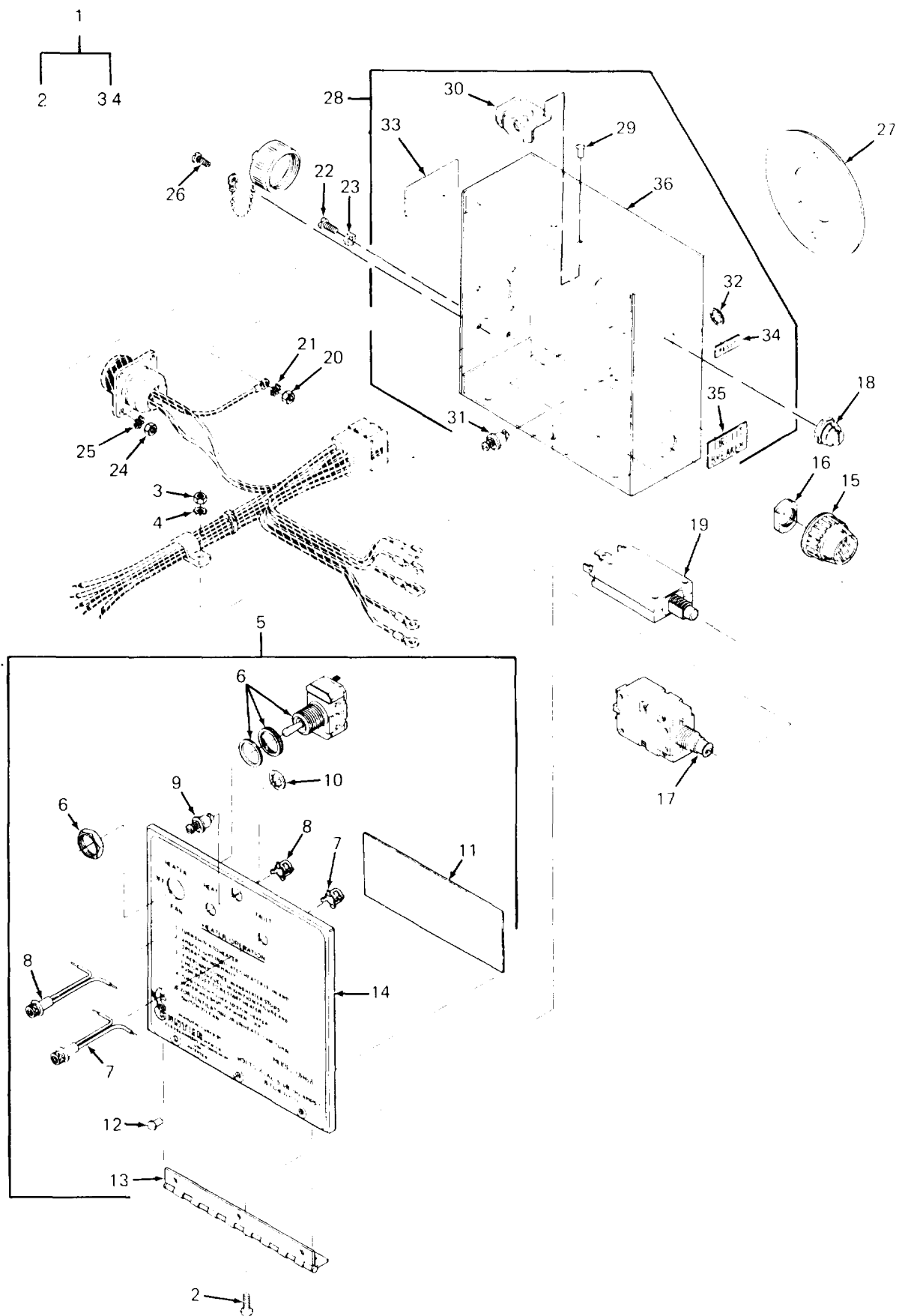

Figure 4. Control Box Assembly

SECTION II (1) ITEM NO	(2) SMR CODE	(3) FSCM	TM5-4520-253-23P (4) PART NUMBER	(5) DESCRIPTION AND USABLE ON CODE (UOC)	(6) QTY
GROUP 01 CONTROL BOX ASSEMBLY					
FIG. 4 CONTROL BOX ASSEMBLY					
1	XBOOO	92878	168216	CONTROL BOX ASSEMBLY	1
2	PAOZZ	96906	MS35206-228	SCREW,MACHINE ROUND HEAD,#6-32 X 3/8 IN. LG	3
3	PAOZZ	96906	MS35649-262	NUT,PLAIN,HEXAGON	3
4	PAOZZ	96906	MS35335-30	WASHER,LOCK EXTERNAL TOOTH,#6	3
5	XBOOO	92878	168218	COVER SUBASSEMBLY, CONTROL BOX	1
6	PAOZF	96906	MS35059-21	SWITC,TOGGLE	1
7	PAOZZ	55292	700-1-7-RA9X	LIGHT,INDICATOR (RED) INCLUDES BARREL FASTENER	1
8	PAOZZ	55292	700-1-10-RA9X	LIGHT,INDICATOR (WHITE) INCLUDES BARRELL FASTENER	1
9	PAOZZ	71286	26S8-3	STUD ASSEMBLY,TURNL	1
10	PAOZZ	71286	2600-LW	WASHER,LOCK INTERNAL TOOTH	1
11	XDOZZ	92878	168530	LABEL,CAUTION	1
12	PAOZZ	96906	MS16535-115	RIVET,TUBULAR	3
13	XBOZZ	92878	68313	HINGE,CONTROL BOX	1
14	XBOZZ	92878	168271	COVER,CONTROL BOX	1
15	PAOZZ	97539	4082	BOOT,DUST AND MOIST INCLUDES BONDED INTERNAL NUT	1
16	XBOZZ	97539	7	ADAPTER,SEAL	1
17	PAOZZ	96906	MS25244-20	CIRCUIT BREAKER	1
18	PAOZZ	06402	N 1 480 08	BOOT,RESET SEAL INCLUDES BONDED INTERNAL KNURLED NUT	1
19	PAOZZ	06402	45-700-IG1-P10-A 3-010	CIRCUIT BREAKER	1
20	PAOZZ	96906	MS35649-262	NUT,PLAIN,HEXAGON	1
21	PAOZZ	96906	MS35335-30	WASHER,LOCK EXTERNAL TOOTH,#6	1
22	PAOZZ	96906	MS35206-230	SCREW,MACHINE ROUND HEAD,#6-32 X 1/2 IN. LG	1
23	PAOZZ	96906	MS45904-54	WASHER,LOCK EXTERNAL/INTERNAL TOOTH,#6	1
24	PAOZH	96906	MS35649-242	NUT,PLAIN,HEXAGON #4-40	4
25	PAOZZ	96906	MS35335-29	WASHER,LOCK EXTERNAL TOOTH,#4	4
26	PAOZZ	96906	MS35206-214	SCREW,MACHINE ROUND HEAD,#4-40 X 5/16 IN. LG	4
27	XDOZZ	92878	168046	GASKET	1
28	XBOZZ	92878	168217	CONTROL BOX SUBASSEMBLY	1
29	PAOZZ	96906	MS16535-54	RIVET,TUBULAR	2
30	XBOZZ	71286	212-12B-R	RECEPTACLE,TURNLOCK	1
31	XDOZZ	71286	26S8-2	STUD,ASSEMBLY,TURNL	2
32	PAOZZ	71286	2600-LW	WASHER,LOCK INTERNAL TOOTH	2
33	PAOZZ	92878	68708-05	DECAL	1
34	PAOZZ	92878	168156	LABEL	1
35	PAOZZ	92878	168524	LABEL BREAKER	1
36	XBOZZ	92878	168249	CONTROL BOX	1

END OF FIGURE

1

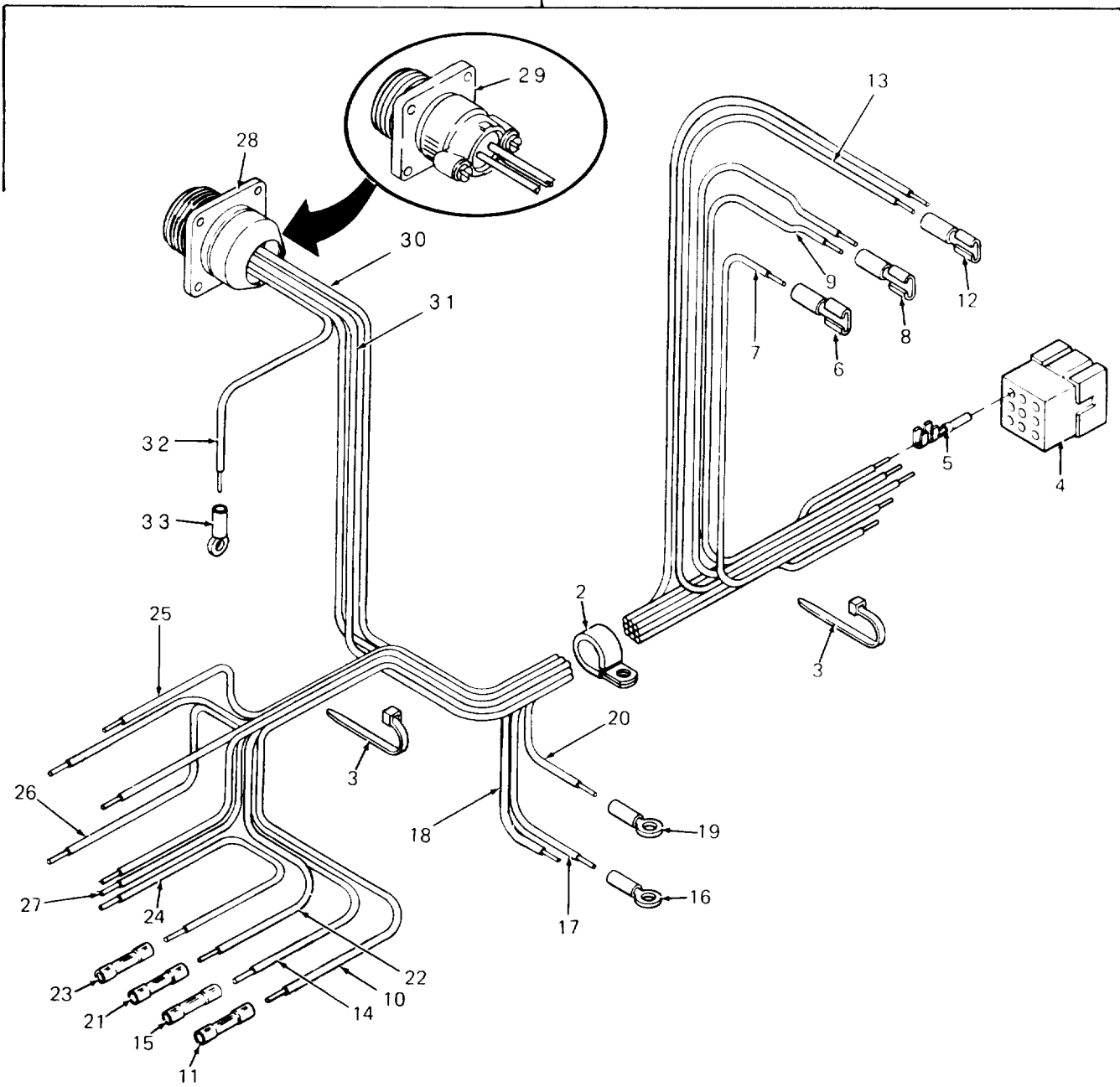

Figure 5. Control Box Harness Assembly

SECTION II (1) ITEM NO	(2) SMR CODE	(3) FSCM	TM5-4520-253-23P (4) PART NUMBER	(5) DESCRIPTION AND USABLE ON CODE (UOC)	(6) QTY
GROUP 01 CONTROL BOX ASSEMBLY					
FIG. 5 CONTROL BOX HARNESS ASSEMBLY					
1	XBOOO	92878	168225	HARNESS,CONTROL BOX	1
2	PAOZZ	78553	C-4980-A-4-35	CLAMP,LOOP	2
3	PAOZZ	96906	MS3367-1-9	STRAP,TIEDOWN,ELECT	2
4	XBOZZ	27264	03-09-2092	PLUG	1
5	XBOZZ	27264	1190-02-09-2103	TERMINAL,FEMALE	8
6	PAOZZ	14726	S09718SF	TERMINAL,QUICK DISC DISCONNECT, FEMALE,16-14 AWG	1
7	MOOZZ	92878	10799	WIRE,ELECTRICAL, 20 GA.,GREY,11 1/4 IN.LG.MFR.FROM P/N M16878/ 1BGE8 (81349)	1
8	PAOZZ	14726	S09718SF	TERMINAL,QUICK DISC DISCONNECT, FEMALE,16-14 AWG	1
9	MOOZZ	92878	10770-23	WIRE,ELECTRICAL, 16 GA.,YELLOW,6 3/4 IN.LG.MFR.FROM P/N M16878/1BJE4 (81349)	1
10	MOOZZ	92878	10795-03	WIRE,ELECTRICAL, 20 GA.,YELLOW,8 3/4 IN.LG.MFR.FROM P/N M16878/ 1BGE4 (81349)	1
11	XDOZZ	00779	34070	SPLICE,CONDUCTOR 22-16AWG	1
12	PAOZZ	14726	S09718SF	TERMINAL,QUICK DISC DISCONNECT, FEMELE,16-14 AWG	1
13	MOOZZ	92878	10739-03	WIRE,ELELCTRICAL, 20 GA.,VIOLET,8 3/4 IN.LG.MFR.FROM P/N M16878/1BGE7 (81349)	1
14	MOOZZ	92878	10739-03	WIRE,ELECTRICAL, 20 GA.,VIOLET,8 3/4 IN.LG.MFR.FROM P/N M16878/1BGE7 (81349)	1
15	XDOZZ	00779	34070	SPLICE,CONDUCTOR 22-16 AWG	1
16	PAOZZ	96906	MS25036-108	TERMINAL.LUG NO. 10 STUD,16-14 AWG.,INSULATED BARREL	1
17	MOOZZ	92878	10767-09	WIRE,ELECTRICAL, 16 GA.,BROWN,5 IN.LG.,MFR.FROM P/N M16878/1BJE1 (81349)	1
18	MOOZZ	92878	10767-05	WIRE,ELECTRICAL, 16 GA.,BROWN,8 IN.LG.,MFR.FROM P/N M16878/1BJE1 (81349)	1
19	PAOZZ	96906	MS25036-108	TERMINAL.LUG NO.10 STUD.16-14 AWG.,ISULATED BARREL	1
20	MOOZZ	92878	10772-11	WIRE,ELECTRICAL 16 GA.,BLACK,5 IN.LG.MFR.FROM P/N M16878/1BJE0 (81349)	1
21	XDOZZ	00779	34070	SPLICE,CONDUCTOR 22-16 AWG	1
22	MOOZZ	92878	10782-13	WIRE,ELECTRICAL, 20 GA.,WHITE,7 1/2 IN.LG.MFR.FROM P/N M16878/1BGE9 (81349)	1
23	XDOZZ	00779	34070	SPLICE,CONDUCTOR 22-16 AWG1	1
24	MOOZZ	92878	10736-06	WIRE,ELECTRICAL, 20 GA.,ORANGE,3	1

SECTION II (1)	ITEM (2)	(3)	TM5-4520-253-23P (4)	(5)	(6)
NO	SMR CODE	FSCM	PART NUMBER	DESCRIPTION AND USABLE ON CODE (UOC)	QTY
25	MOOZZ	92878	10774-30	IN.LG.,MFR.FROM P/N M16878/1BGE3 (81349) WIRE,ELECTRICAL, 16 GA.,RED,10 3/ 4 IN.LG.MFR.FROM P/N M16878/1BJE2 (81349)	1
26	MOOZZ	92878	10799-06	WIRE,ELECTRICAL, 20 GA.,GREY,9 3/ 4 IN.LG.MFR.FROM P/N M16878/1BGE8 (81349)	1
27	MOOZZ	82878	10736-02	WIRE,ELECTRICAL 20 GA.,ORANGE,9 1/2 IN.LG.,MFG.FROM P/N M16878/ 1BGE3 (81349)	1
28	XDOZZ	96906	MS3103-14S7S	CONNECTOR,RECEPTAL (ROOM THERMO)	1
29	XDOZZ	96906	MS3100R-14S-7S	CONNECTOR,RECEPTACL (ROOM THERMO)	1
30	MOOZZ	92878	10766-12	UOC:ETG WIRE,ELECTRICAL 16 GA.,ORANGE,9 1/2 IN.LG.MFR.FROM P/N M16878/1BJE3 (81349)	1
31	MOOZZ	92878	10785-01	WIRE,ELECTRICAL, 20GA.,GREEN,5 IN.LG.FROM P/N M16878/1BGE5 (81349)	1
32	MOOZZ	92878	10785-03	WIRE,ELECTRICAL 20 GA.,GREEN,3 IN.LG.,MFR.FROM P/N M16878/1BGE5 (81349)	1
33	PAOZF	96906	MS25036-102	TERMINAL,LUG TONGUE,INSULATED,16- 14 AWG	1

END OF FIGURE

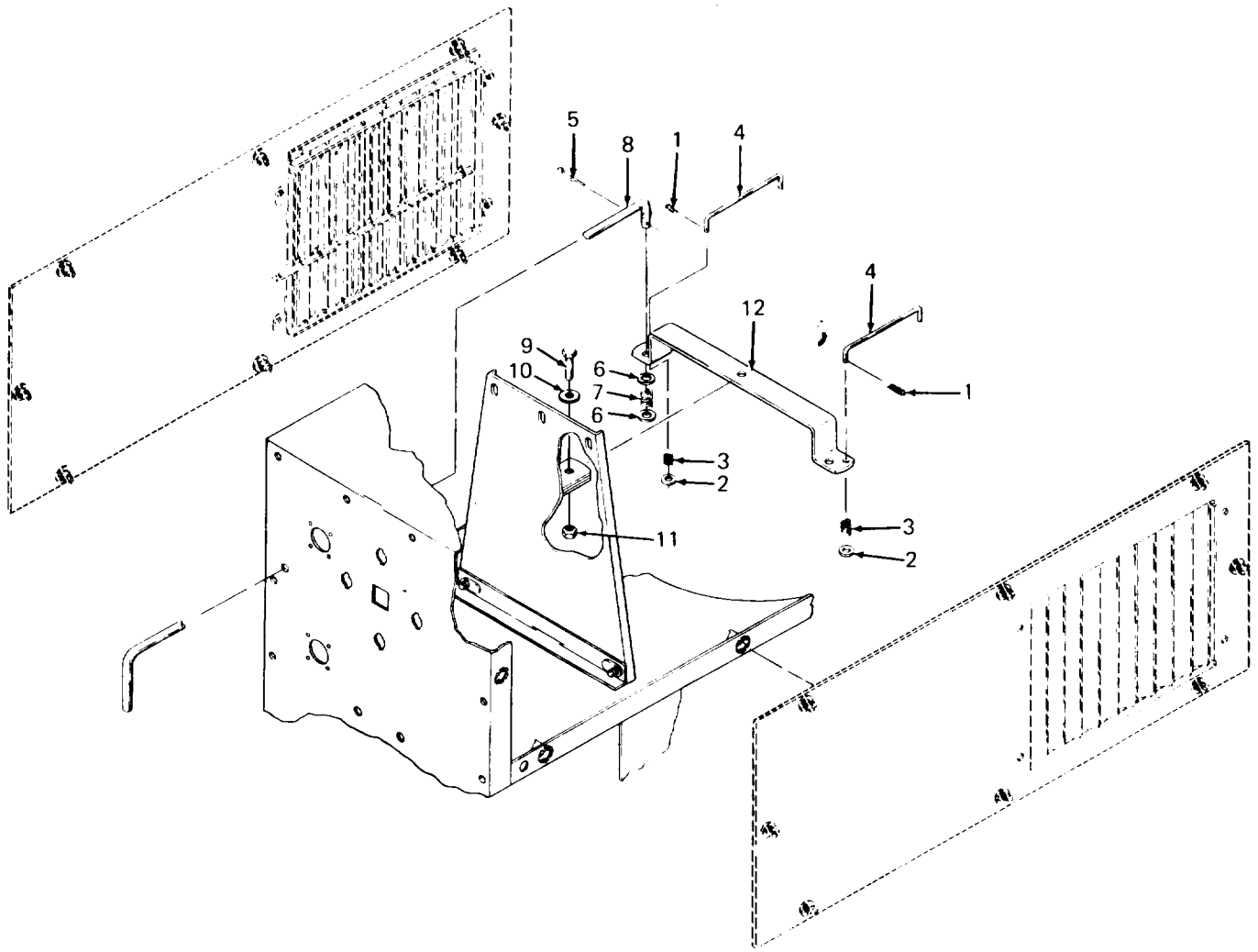

Figure 6. Side Panels and Louver Linkage

SECTION 11 (1)	(2)	(3)	TM5-4520-253-23P (4)	(5)	(6)
ITEM NO	SMR CODE	FSCM	PART NUMBER	DESCRIPTION AND USABLE ON CODE (UOC)	QTY
GROUP 02 HEATER CASE ASSEMBLY					
FIG. 6 SIDE PANELS AND LOUVER LINKAGE					
1	PAOZZ	65029	26	PIN, LOCK	2
2	PAOZZ	96906	MS27183-5	WASHER, FLAT	2
3	PBOZZ	92878	68711	SPRING, HELICAL, COMP	2
4	XBOZZ	92878	68662-01	LINKAGE, LOUVER	2
5	PAOZZ	96906	MS24665-285	PIN, COTTER 3/32 IN. DIA. X 1 IN. LG	1
6	XBOZZ	92878	47172	WASHER, FLAT, 17/64 I.D. X 7/16 O.D.	2
7	PAOZ	24658	80861-45	SPRING, HELICAL, COMP	1
8	XBOZZ	92878	68671-01	HANDLE, LOUVER OPERATING	1
9	PAOZH	96906	MS90725-6	SCREW, CAP, HEXAGON H HEXAGON HEAD	1
10	XBOZZ	92878	65838	WASHER, FLAT 1/4 I.D. X 1 O.D	1
11	PAOZZ	96906	MS51922-1	NUT, SELF-LOCKING, HE 1/4-20	1
12	XBOZZ	92878	68754	BAR, PIVOT, CONTROL	1

END OF FIGURE

SECTION II					
(1)	(2)	(3)	(4)	(5)	(6)
ITEM NO	SMR CODE	FSCM	PART NUMBER	DESCRIPTION AND USABLE ON CODE (UOC)	QTY
TM5-4520-253-23P					
GROUP 02 HEATER CASE ASSEMBLY					
FIG. 7 RIGHT HAND LOUVER PANEL ASSEMBLY					
1	XBOOO	92878	168235	PANEL ASSEMBLY, RIGHT HAND LOUVER	1
2	PAOZZ	71286	26S8-3	STUD ASSEMBLY,TURNL	8
3	PAOZZ	71283	2600-LW	WASHER,LOCK INTERNAL TOOTH	8
4	PAOZZ	96906	MS16535-133	RIVET,TUBULAR 1/8 IN. DIA. X 5/32 IN. LG.,BRASS	3
5	XBOZZ	92878	68761	LOCK,LOUVER,RIGHT HAND	1
6	XBOOO	92878	2-68756	LOUVER SUBASSEMBLY, RIGHT HAND	1
7	PAOZZ	96906	MS16535-115	RIVET,TUBULAR	10
8	XAOZZ	92878	168149	LOUVER,RIGHT HAND	10
9	XAOZZ	92878	68748	BAR,LOUVER CONTROL	1
10	XBOZZ	92878	168233	PANEL,LOUVER, RIGHT HAND	1

END OF FIGURE

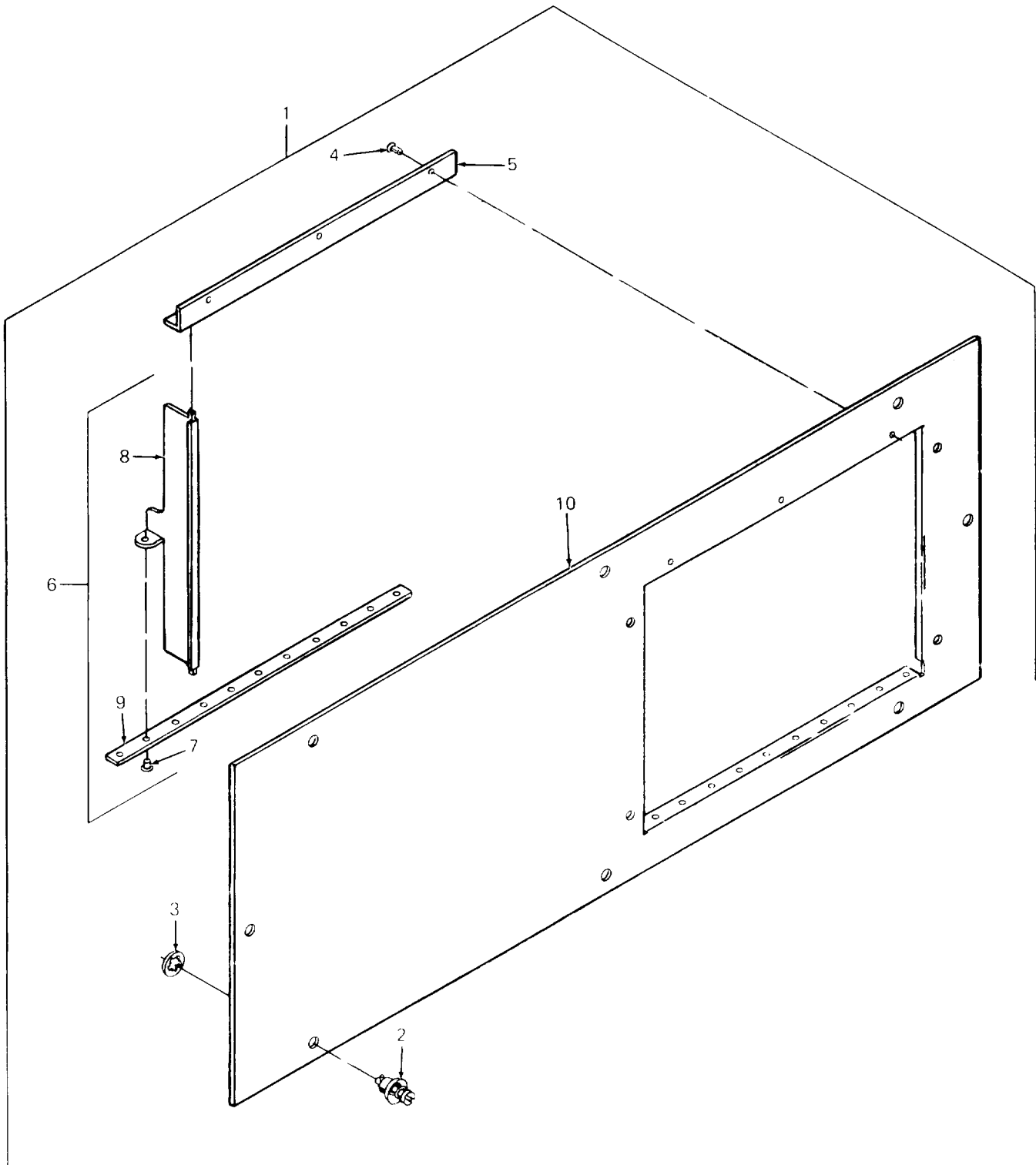

Figure 8. Left Hand Louver Panel Assembly

SECTION II					
(1)	(2)	(3)	(4)	(5)	(6)
ITEM NO	SMR CODE	FSCM	PART NUMBER	DESCRIPTION AND USABLE ON CODE (UOC)	QTY
TM5-4520-253-23P					
GROUP 02 HEATER CASE ASSEMBLY					
FIG. 8 LEFT HAND LOUVER PANEL ASSEMBLY					
1	XBOOO	92878	168232	PANEL ASSEMBLY, LEFT HAND LOUVER	1
2	PAOZZ	71286	26S8-3	STUD ASSEMBLY,TURNL	8
3	PAOZZ	71286	2600-LW	WASHER,LOCK INTERNAL TOOTH	8
4	PAOZZ	96906	MS16535-133	RIVET,TUBULAR 1/8 IN. DIA. X 5/32 IN.LG.,BRASS	3
5	XBOZZ	92878	68751	LOCK,LOUVER,LEFT HAND	1
6	XBOOO	92878	2-68746	LOUVER,SUBASSEMBLY, LEFT HAND	1
7	PAOZZ	96906	MS16535-115	RIVET,TUBULAR	10
8	XAOZZ	92878	168148	LOUVERLEFT HAND	10
9	XAOZZ	92878	68748	BAR,LOUVER CONTROL	1
10	XBOZZ	92878	168230	PANEL,LOUVER,LEFT HAND	1

END OF FIGURE

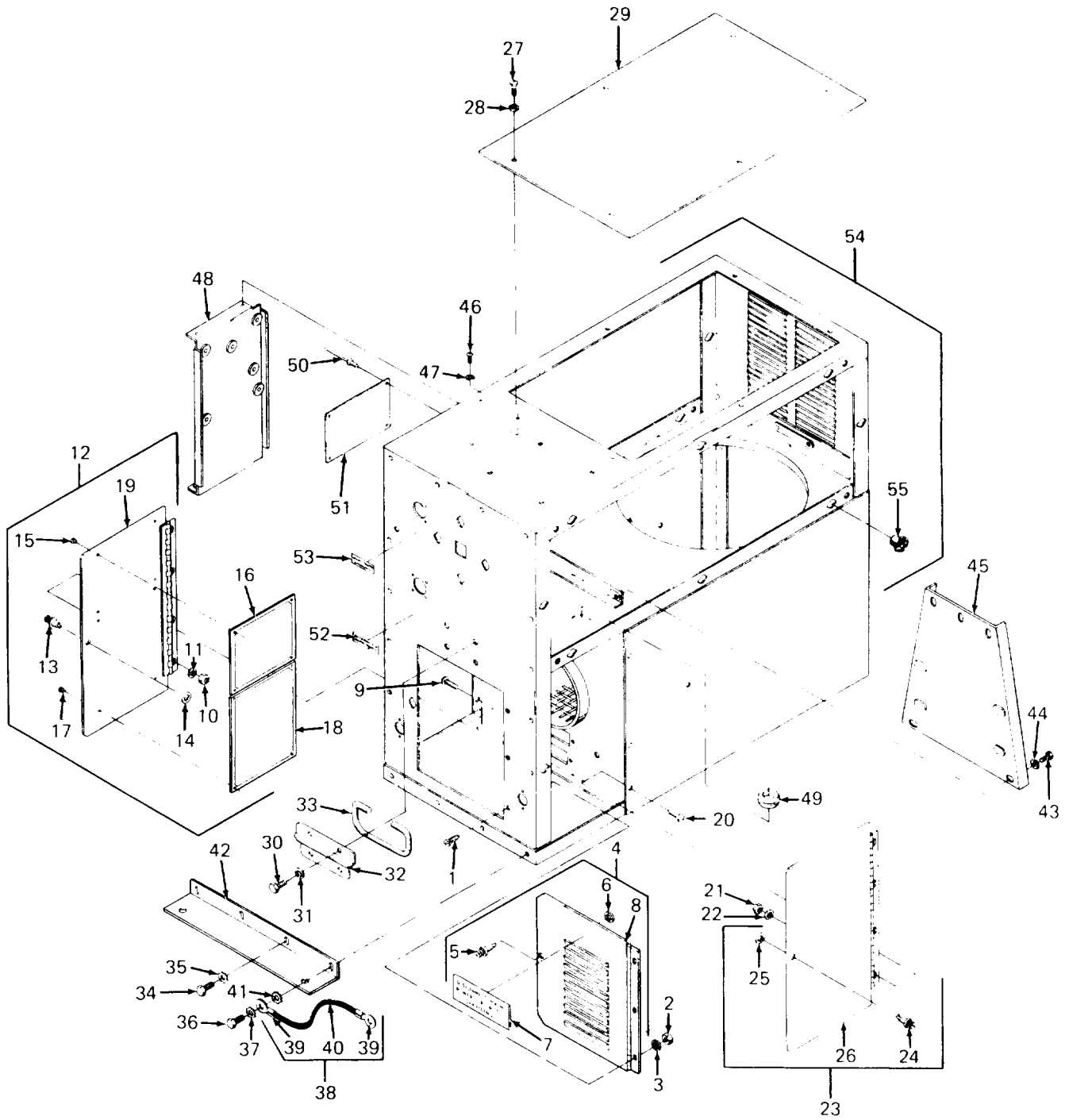

Figure 9. Heater Case Assembly

SECTION II (1)	ITEM (2)	(3)	TM5-4520-253-23P (4)	(5)	(6)
NO	SMR CODE	FSCM	PART NUMBER	DESCRIPTION AND USABLE ON CODE (UOC)	QTY
GROUP 02 HEATER CASE ASSEMBLY					
FIG. 9 HEATER CASE ASSEMBLY					
1	PAOZO	96906	MS35206-261	SCREW,MACHINE PAN HEAD	3
2	PAOZH	96906	MS35649-202	NUT,PLAIN,HEXAGON #10-24	3
3	PAOZZ	96906	MS35333-39	WASHER,LOCK INTERNAL TOOTH	3
4	XBOZZ	92878	168241	DOOR SUBASSEMBLY, FRONT ACCESS	1
5	PAOZZ	71286	26S8-3	STUD ASSEMBLY,TURNL	1
6	PAOZZ	71286	2600-LW	WASHER,LOCK INTERNAL TOOTH	1
7	XDOZZ	92878	168530	LABEL,CAUTION	1
8	XBOZZ	92878	168242	DOOR,FRONT ACCESS	1
9	PAOZO	96906	MS35206-261	SCREW,MACHINE PAN HEAD	4
10	PAOZF	96906	MS35649-202	NUT,PLAIN,HEXAGON #10-24	4
11	PAOZZ	96906	MS35333-39	WASHER,LOCK INTERNAL TOOTH	4
12	XBOZZ	92878	168255	DOOR ASSEMBLY, RIGHT	1
13	PAOZZ	71286	26S8-3	STUD ASSEMBLY,TURNL	1
14	PAOZZ	71286	2600-LW	WASHER,LOCK INTERNAL TOOTH	1
15	PAOZZ	96906	MS16535-133	RIVET,TUBULAR 1/8 DIA. X 5/32 IN.LG.,BRASS	4
16	XBOZZ	92878	168252	PLATE,INSTUCTION	1
17	PAOZZ	96906	MS16535-133	RIVET,TUBULAR 1/8 DIA. X 5/32 LG., BRASS	4
18	XBOZZ	92878	168296	PLATE,WIRING DIAGRAM	1
19	XBOZZ	92878	168253	DOOR,RIGHT SIDE	1
20	PAOZO	96906	MS35206-261	SCREW,MACHINE PAN HEAD	4
21	PAOZF	96906	MS35649-202	NUT,PLAIN,HEXAGON #10-24	4
22	PAOZZ	96906	MS35333-39	WASHER,LOCK INTERNAL TOOTH	4
23	XBOZZ	92878	2-168006	DOOR ASSEMBLY,LEFT	1
24	PAOZZ	71286	26S8-3	STUD ASSEMBLY,TURNL	1
25	PAOZZ	71286	2600-LW	WASHER,LOCK INTERNAL TOOTH	1
26	XBOZZ	92878	2-68619	DOOR,LEFT SIDE	1
27	PAOZO	96906	MS35206-261	SCREW,MACHINE PAN HEAD	6
28	PAOZZ	96906	MS35333-39	WASHER,LOCK INTERNAL TOOTH	6
29	XBOZZ	92878	68706	COVER,BOTTOM, HEATER CASE	1
30	PZOZF	96906	MS90725-3	SCREW,CAP,HEXAGON H HEXAGON HEAD	8
31	PAOZH	96906	MS35333-40	WASHER,LOCK INTERNAL TOOTH	8
32	XBOZZ	92878	58621	PLATE,HANDLE	2
33	XBOZZ	92878	58620	HANDLE,CARRYING	2
34	PAOZF	96906	MS90725-3	SCREW,CAP,HEXAGON H HEXAGON HEAD	7
35	PAOZZ	96906	MS35335-33	WASHER,LOCK EXTERNAL TOOTH	7
36	PAOZO	96906	MS90725-5	SCREW,CAP,HEXAGON H HEXAGON HEAD	1
37	PAOZZ	96906	MS35335-33	WASHER,LOCK EXTERNAL TOOTH	1
38	PAOZZ	92878	2-68828	LEAD,ELECTRIAL ASSEMBLY	1
39	PAOZZ	14726	R3458BT	TERMINAL,LUG	2
40	PAOZZ	92878	10534-01	TERMINAL STRIP.GROU 5 IN. REQUIRED	1
41	PAOZZ	96906	MS45904-68	WASHER,LOCK EXTERNA/INTERNAL TOOTH	1
42	XBOZZ	92878	168018	BRACKET,MOUNTING	2
43	PAFZF	96906	MS90725-3	SCREW,CAP,HEXAGON H HEXAGON HEAD	5
44	PAFZZ	96906	MS35335-33	WASHER,LOCL EXTERNAL TOOTH	5
45	XBFZZ	92878	2-168111	BULKHEAD ASSEMBLY	1

SECTION II				TM5-4520-253-23P	
(1)	(2)	(3)	(4)	(5)	(6)
ITEM NO	SMR CODE	FSCM	PART NUMBER	DESCRIPTION AND USABLE ON CODE (UOC)	QTY
46	PAFZO	96906	MS35206-261	SCREW,MACHINE PAN HEAD	4
47	PAFZZ	96906	MS35333-39	WASHER,LOCK INTERNAL TOOTH	4
48	XBFFZ	92878	168299	PLATE ASSEMBLY, P.C. BOARD MOUNTING	1
49	XBOZZ	70485	1418	GROMMET,NONMETALLIC	2
50	PAOZZ	20054	SB4-2	RIVET,BLIND 1/8 IN. DIA X 3237 IN. LG	4
51	XBOZZ	92878	170559	PLATE, IDENTIFICATION	1
52	PAOZZ	92878	168059	LABEL RECEPTACLE	1
53	PAOZZ	92878	68708-02	LABEL RECEPTACLE	1
54	XBFFF	92878	2-168195	HEATER CASE ASSEMBLY, UH68G	1
55	PAOZZ	71286	26R41-1-1AA	RECEPTACLE,FRONT MO	23

END OF FIGURE

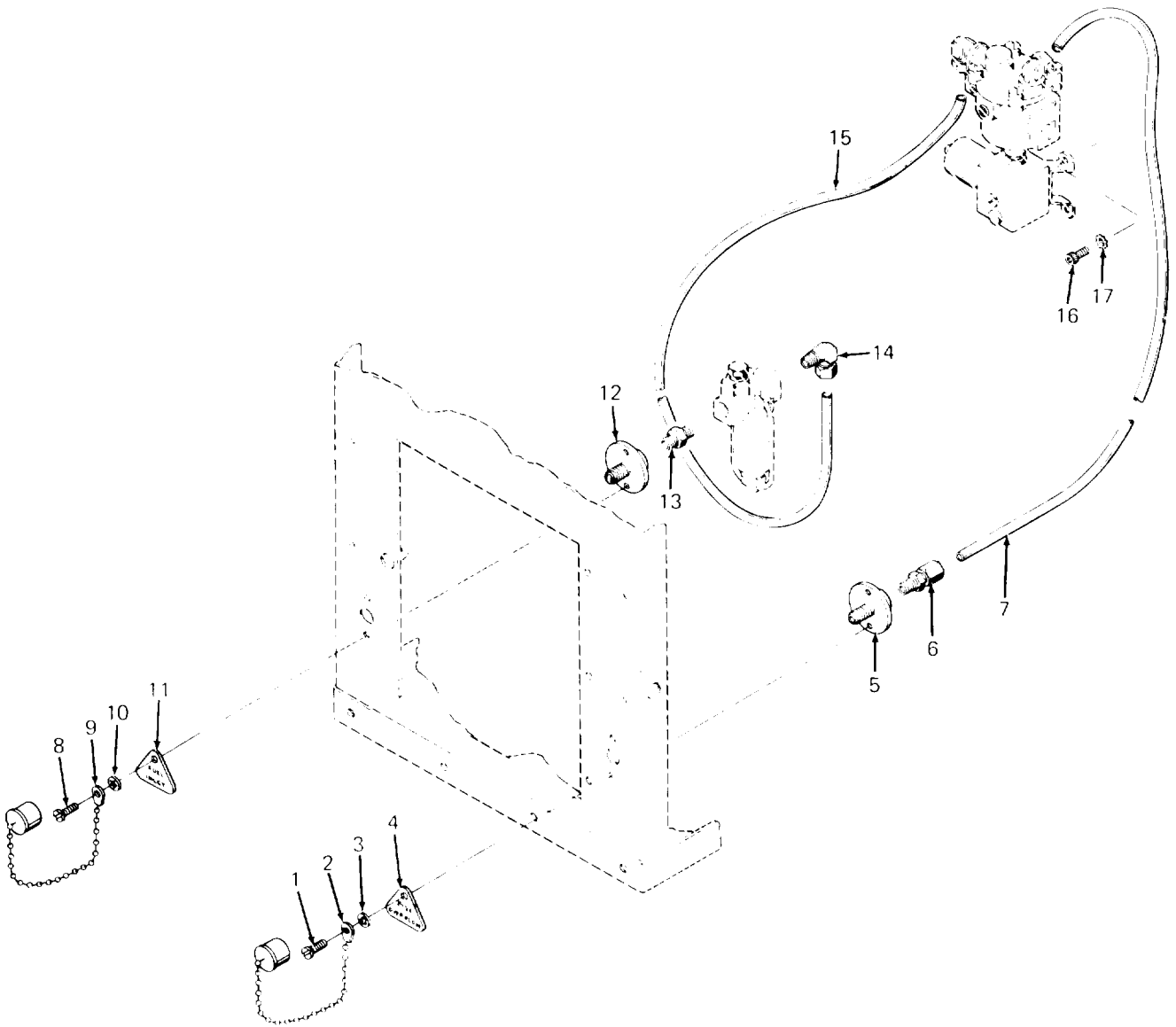

Figure 10. Carburetor and Fittings

SECTION II (1)	SMR (2)	FSCM (3)	TM5-4520-253-23P PART NUMBER (4)	DESCRIPTION AND USABLE ON CODE (UOC) (5)	QTY (6)
GROUP 03 FUEL SYSTEM					
FIG. 10 CARBURETOR AND FITTINGS					
1	PAOZF	96906	MS35206-242	SCREW,MACHINE PAN HEAD	2
2	PAOZZ	92878	168102	CAP PLUG INCLUDES 4 IN.CHAIN AND LUG	1
3	PAOZZ	96906	MS35333-38	WASHER,LOCK INTERNAL TOOTH	2
4	XBOZZ	92878	168244-02	FUEL TAG,OVERLFOV	1
5	PAOZZ	92878	68330	CONNECTOR,FUEL HEAT	1
6	PAOZZ	93061	68CA-4-2	ADAPTER,STRAIGHT,PI	1
7	PAOZ	92878	10662-03	TUBING,NONMETALLIC 11 IN.REQD., INCLUDES P/N 68CA-4-2 (93061),P/N 4-CB12-B(45681)	1
8	PAOZF	96906	MS35206-242	SCREW,MACHINE PAN HEAD	2
9	PAOZZ	92878	168102	CAP PLUG INCLUDES 4 IN.CHAIN AND LUG	1
10	PAOZZ	96906	MS35333-38	WASHER,LOCK INTERNAL TOOTH	2
11	XBOZZ	92878	168244-01	FUEL TAG,INLET	1
12	PAOZZ	92878	68330	CONNECTOR,FUEL HEAT	1
13	PAOZZ	79470	3325X2	NIPPLE,PIPE HEXAGON,1/8 I.P.T	1
14	PAOZZ	30780	4CB12B	ELBOW,PIPE TO TUBE 1/8 I.P.T. - 1/4 IN. TUBE	1
15	PAOZZ	92878	10662-03	TUBING,NONMETALLIC 11 IN.REQD., INCLUDES P/N 4CB (45681) 2 EA	1
16	XBOZZ	92878	7520	SCREW,CAP, SOCKET HEAD,#10-24 X3/8 IN. LG	4
17	PAOZZ	96906	MS35335-32	WASHER,LOCK EXTERNAL TOOTH	4

END OF FIGURE

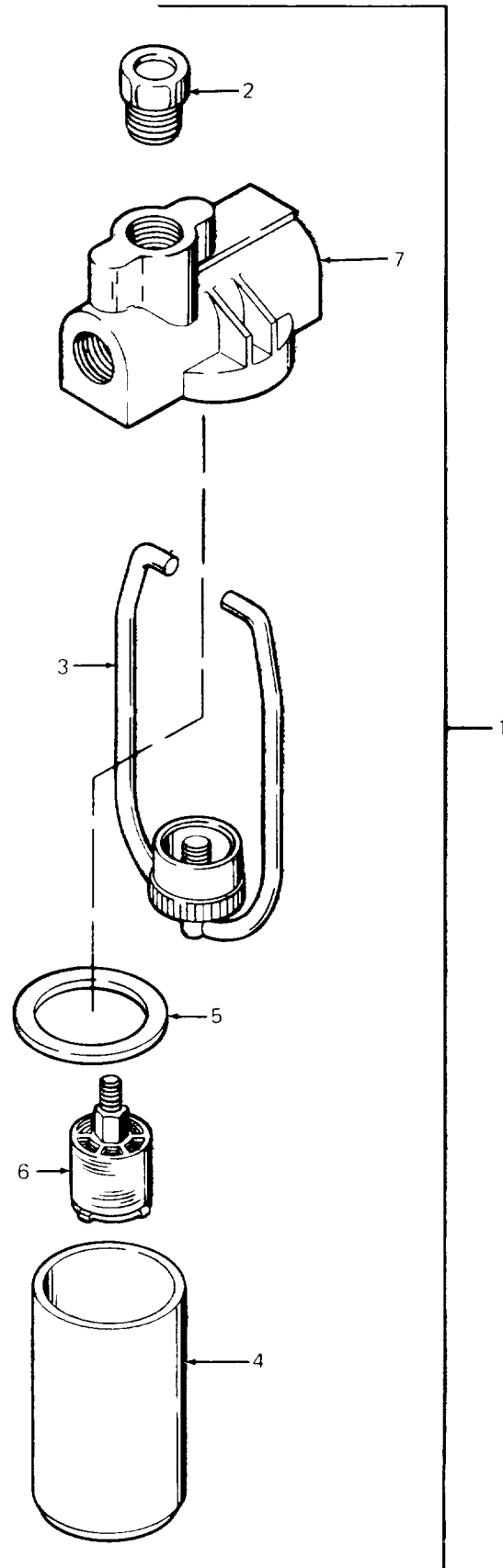

Figure 11. Fuel Filter Assembly

SECTION II					
(1)	(2)	(3)	(4)	(5)	(6)
ITEM NO	SMR CODE	FSCM	PART NUMBER	DESCRIPTION AND USABLE ON CODE (UOC)	QTY
TM5-4520-253-23P					
GROUP 03 FUEL SYSTEM					
FIG. 11 FUEL FILTER ASSEMBLY					
1	PAOZO	96906	MS51086-1	STRAINER, SIDIMENT	1
2	XBOZZ	19207	A5277290	PLUG, PIPE	1
3	XAOZZ	79960	F10X3	BAIL	1
4	XAOZZ	79960	F8X56	BOUWL, FILTER	1
5	PAOZZ	79960	FIX38	GASKET	1
6	PAOZZ	79960	F2X79T3	FILTER ELEMENT, FLUIT	1
7	XAOZZ	79960	F7X184	HEAD, FILTER	1
END OF FIGURE					

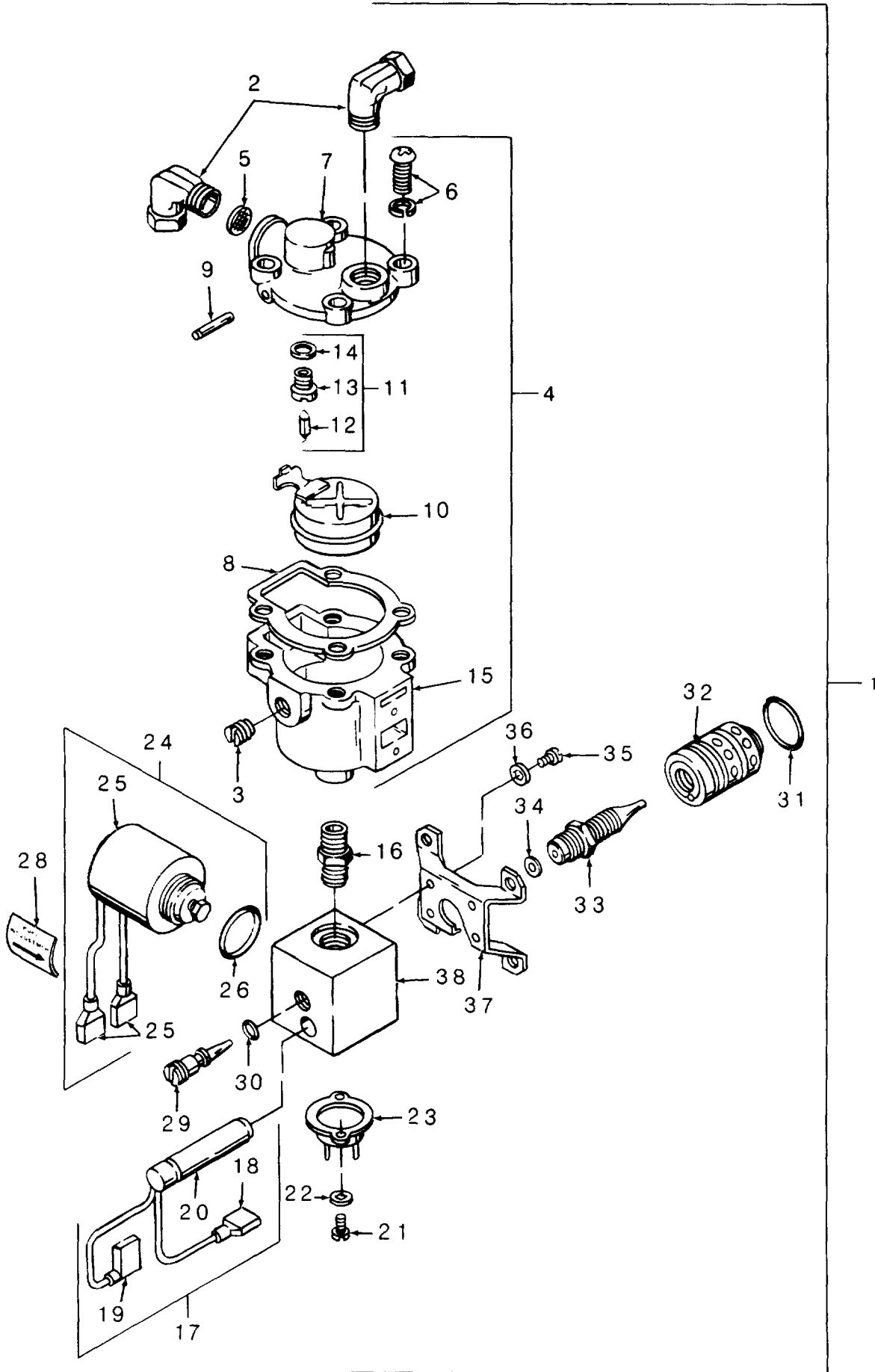

Figure 12. Carburetor Assembly

SECTION II (1) ITEM NO	(2) SMR CODE	(3) FSCM	TM5-4520-253-23P (4) PART NUMBER	(5) DESCRIPTION AND USABLE ON CODE (UOC)	(6) QTY
GROUP 03 FUEL SYSTEM					
FIG. 12 CARBURETOR ASSEMBLY					
1	PAOOO	92878	168198	CARBURETOR,HEATER	1
2	PAOZZ	30780	4CB12B	ELBOW,PIPE TO TUBE 1/8 I.P.T. - I/ 4 IN. TUBE	2
3	XDOZZ	59501	10-17966	PLUG,PIPE BRASS,1/8 I.P.T	1
4	XBOZZ	96152	013440	FLOAT,CORBURETOR	1
5	PAOZZ	96152	95-164	STRAINER ELEMENT ,SE	1
6	XBOZZ	19207	454430	SCREW, INCLUDES LOCK WASHER	4
7	XBOZZ	96152	07397	COVER	1
8	PAOZZ	96152	07398	GASKET	1
9	XBOZZ	96152	0700	PIN,STRAIGHT,HEADLE	1
10	XBOZZ	96152	013441	FLOAT	1
11	PAOZZ	96152	013443	NEEDLE ASSEMBLY,INL ASSEMBLY, INCLUDES WASHER P/N 012641 (96152)	1
12	XBOZZ	96152	012642	NEEDLE	1
13	XAOZZ	96152	012643	SEAT	1
14	XAOZZ	96152	012641	WASHER	1
15	XBOZZ	96152	09196	BODY,FLOAT BOWL	1
16	PAOZZ	79470	3325X2	NIPPLE,PIPE HEXAGON,1/8 I.P.T	1
17	PAOZZ	92878	168263	HEATER,CARBURETOR CARBURETOR	1
18	PAOZZ	14726	S05076	TERMINAL,QUICK DISC MALE,FULLY INSULATED	1
19	PAOZZ	14726	SO5363SFT	TERMINAL QUICK DISC FULLY INSULATED,FEMALE,QUICK DISCONNECT	1
20	XAOZZ	01692	SC37178	HEATER,CARTRIDGE	1
21	PAOZH	96906	MS35206-226	SCREW,MACHINE FILISTER HEAD,6/32 X 1/4 IN. LG	2
22	PAOZZ	96906	MS35333-37	WASHER,LOCK INTERNAL TOOTH	2
23	PAOZZ	92878	5357	SWITCH,THERMOSTATIC PREHEAT	1
24	PAOZZ	92878	168204	FUEL SOLENOID ELECT SUBASSEMBLY	1
25	PAOZZ	14726	S05076	TERMINAL,QUCK DISC MALE,FULLY INSULATED	2
26	XDOZZ	96906	MS9021-005	PACKING,PREFORMED	1
27	XAOZZ	20832	17C0171-3	ACTUATOR,SOLENOID, 24 VOLT	1
28	XBOZZ	92878	47907	LABEL,FUEL ADJUSTMENT	1
29	XBOZZ	92878	49189	NEELDLE,FUEL	1
30	PAOZZ	27877	568-006	PACKING,PROFORMED	1
31	PAOZZ	81349	M83248/1-018	PACKING,PREFORMED	1
32	XBOZZ	92878	2-48113-02	MIXER,FUEL	1
33	XBOZZ	92878	168679	JET,FUEL	1
33	XBOZZ	92878	49323	GASKET,JET 0.010 IN. THK. SOFT COPPER	1
35	PAOZH	96906	MS35206-226	SCREW,MACHINE FILISTER H4EAD,6/32 X 1/4 IN. LG	4
36	PAOZZ	96906	MS35333-37	WASHER,LOCK INTERNAL TOOTH	4
37	XBOZZ	92878	49032	BRACKET	1
38	XBOZZ	92878	168199	BODY,CORBURETOR	1

END OF FIGURE

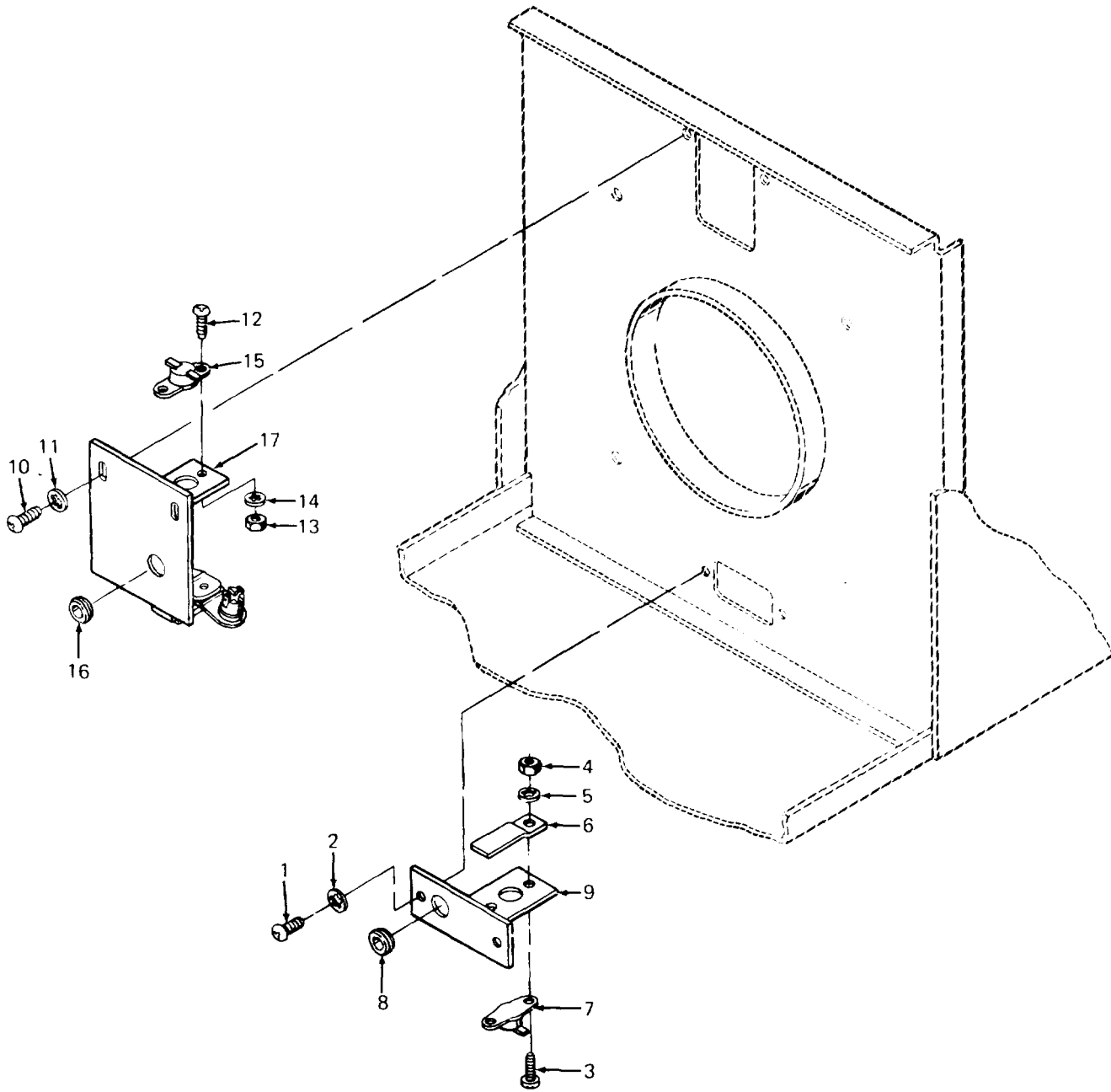

Figure 13. Thermostat and Flame Switch Assemblies

SECTION II (1)	SMR (2)	FSCM (3)	TM5-4520-253-23P (4) PART NUMBER	(5) DESCRIPTION AND USABLE ON CODE (UOC)	(6) QTY
GROUP 04 ELECTRICAL					
FIG. 13 THERMOSTAT AND FLAME SWITCH ASSEMBLIES					
1	PAPZF	96906	MS35206-242	SCREW,MACHINE PAN HEAD	2
2	PAOZZ	96906	MS35333-38	WASHER,LOCK INTERNAL TOOTH	2
3	PAOZZ	96906	MS35206-227	SCREW,MACHINE PAN HEAD	2
4	PAOZZ	96906	MS35649-262	NUT,PLAIN,HEXAGON #6-32	2
5	PAOZZ	96906	MS35333-37	WASHER,LOCK INTERNAL TOOTH	2
6	XBOZZ	92878	168686	SHIELD,THERMOSTAT	1
7	PAOZZ	81439	36T21	SWITCH, THERMOSTATIC	1
8	PAOZZ	05624	AYRZ14	GROMMET ,NONMETALLIC	1
9	XBOZZ	92878	2-168559	BRACKET , THERMOSTAT MOUNTING	1
10	PAOZF	96906	MS35206-242	SCREW,MACHINE PAN HEAD	2
11	PAOZZ	96906	MS35333-38	WASHER,LOCK INTERNAL TOOTH	2
12	PAOZZ	96906	MS35206-227	SCREW,MACHINE PAN HEAD	2
13	PAOZZ	96906	MS35649-262	NUT,PLAIN,HEXAGON #6-32	2
14	PAOZZ	96906	MS35333-37	WASHER,LOCK INTERNAL TOOTH	2
15	PAOZZ	81439	36T21	SWITCH, THERMOSTATIC	1
16	XDOZZ	12204	117957	GROMMET , NONMETALLIC	1
17	XBOZZ	92878	168289	BRACKET , THERMOSTAT MOUNTING (FLAME SWITCH)	1

END OF FIGURE

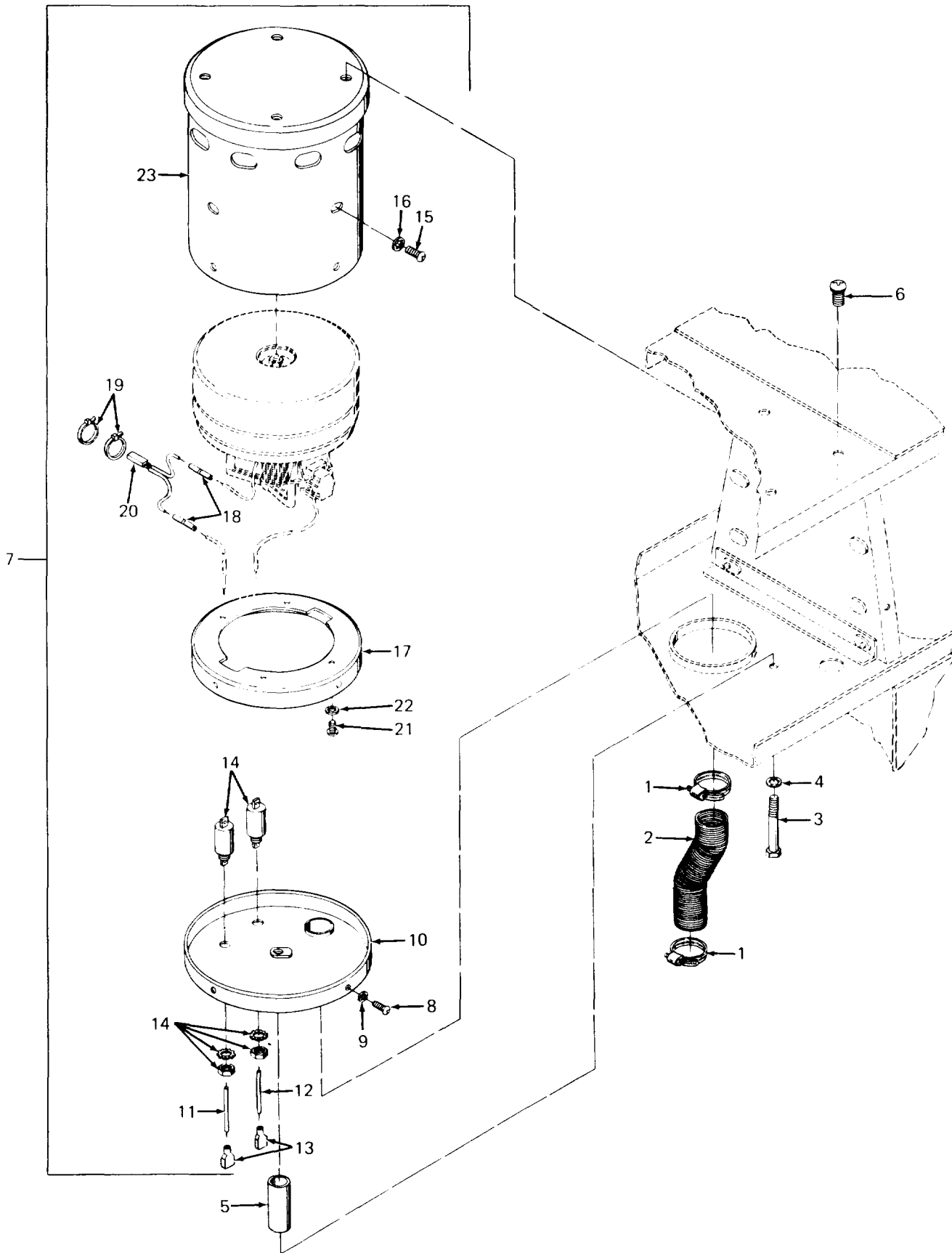

Figure 14. Combustion Blower and Housing

SECTION II (1) ITEM NO	(2) SMR CODE	(3) FSCM	TM5-4520-253-23P (4) PART NUMBER	(5) DESCRIPTION AND USABLE ON CODE (UOC)	(6) QTY
GROUP 04 ELECTRICAL					
FIG. 14 COMBUSTION BLOWER AND HOUSING					
1	PAFZZ	96906	MS35842-11	CLAMP ,HOSE	2
2	PAFZZ	92878	49351-02	HOSE , AIR DUCT	1
3	PAFZZ	96906	MS90725-18	SCREW,CAP,HEXAGON H HEXAGON HEAD	1
4	PAFZH	96906	MS35333-40	WASHER , LOCK INTERNAL TOOTH	1
5	XBFZZ	92878	168294	TUBE , SUPPORT	1
6	PAFZZ	92878	3050	SCREW, SELF-LOCKING WITH LOCK	4
7	PBFFF	92878	168161	WASHER, 1/4-20 X 3/8 IN. LG COMBUSTION BLOWER AND HOUSING ASSEMBLY	1
8	PAFZZ	96906	MS24629-23	SCREW, TAPPING, THREA ROUND HEAD, #6- 32 X 3/8 IN. LG	4
9	PAFZZ	96906	MS35333-37	WASHER, LOCK INTERNAL TOOTH	4
10	XBFZZ	92878	168162	COVER SUBASSEMBLY, BLOWER HOUSING	1
11	MFFZZ	92878	10770-23	WIRE, ELECTRICAL 16 GA., YELLOW,8 IN.LG.FROM P/N M16878/1BJE4 (81349)	1
12	MFFZZ	92878	10781-12	WIRE,ELECTRICAL, 16 GA.,WHITE,7 IN.LG.MFR.FROM P/N M16878/11BJE9 (81349)	1
13	PAFZZ	14726	SO5076	TERMINAL,QUICK DISC	2
14	PAFZZ	92878	170816	CAPACITOR,FIXED,MFT INCLUDES LOCK WASHER AND HEX NUT	2
15	PAFZZ	96906	MS35206-263	SCREW,MACHINE PAN HEAD	4
16	PAFZZ	96906	MS35333-39	WASHER, LOCK INTERNAL TOOTH	4
17	XBFZZ	92878	168192	BLOWER SUPPORT	1
18	PAFZZ	14726	B1870BNT	SPLICE ,CONDUCTOR	2
19	PAFZZ	96906	MS3367-1-9	STRAP , TIEDOWN,ELECT	2
20	PAFZZ	92878	5621	PROTECTOR, THERMAL-O THERMAL	1
21	PAFZZ	96906	MS24629-46	SCREW, TAPPING, THREA	4
22	PAFZZ	96906	MS35333-39	WASHER, LOCK INTERNAL TOOTH	4
23	XBFZZ	92878	168194	BLOWER HOUSING SUBASSEMBLY	1

END OF FIGURE

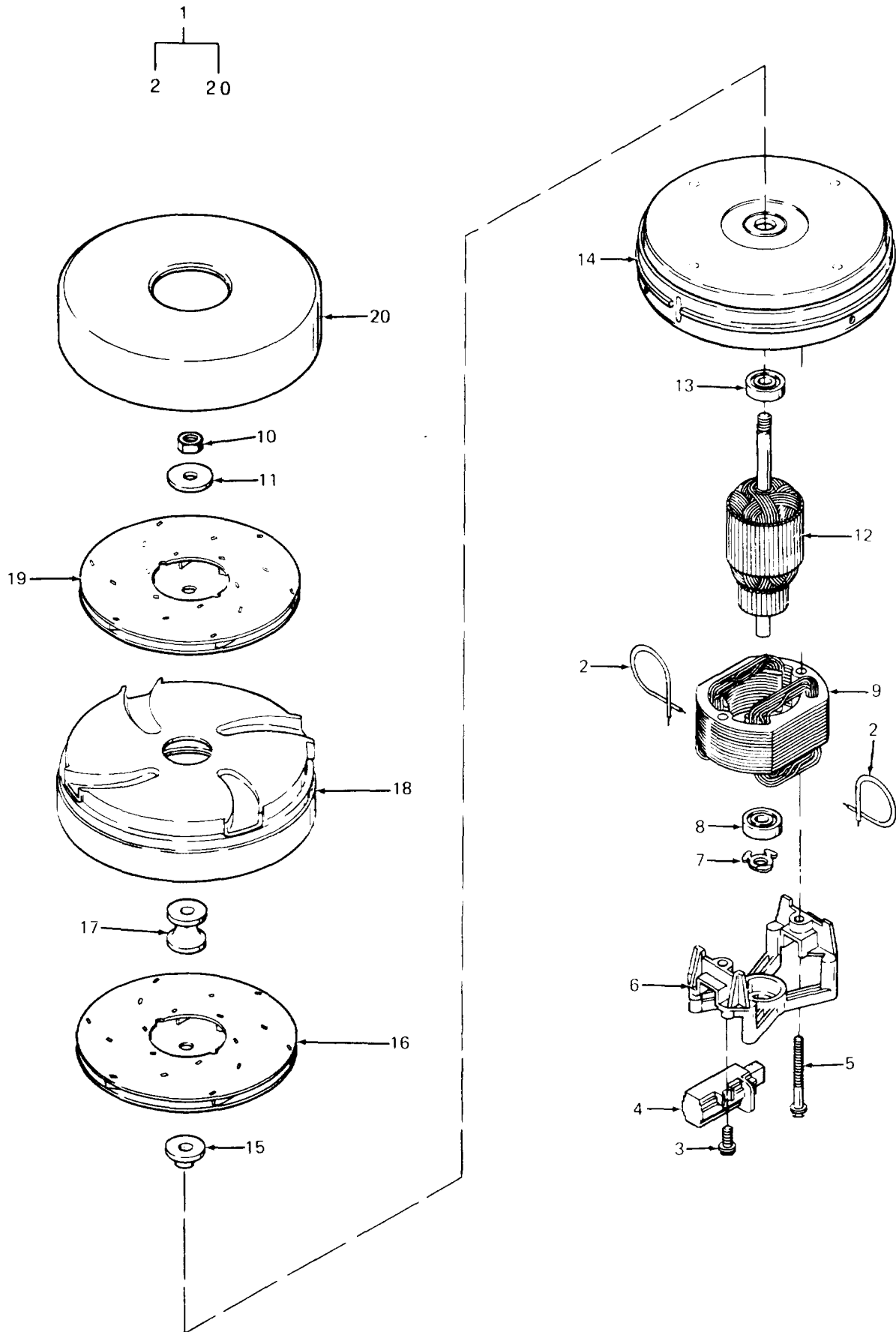

Figure 15. Blower Motor Subassembly

TM 5-4520-253-23P

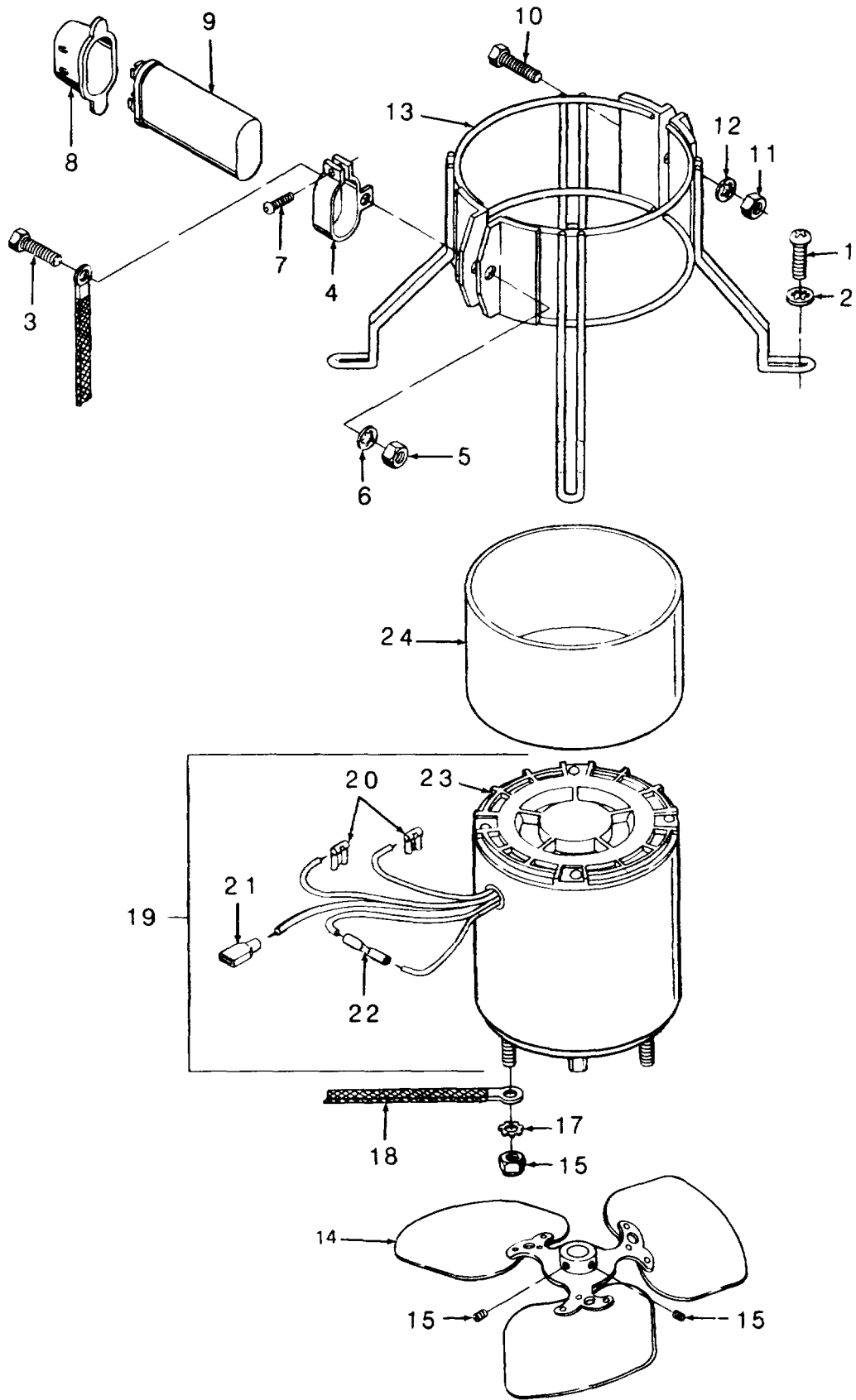

Figure 16. Ventilating Air Motor

SECTION II (1)	SMR (2)	FSCM (3)	TM5-4520-253-23P (4) PART NUMBER	(5) DESCRIPTION AND USABLE ON CODE (UOC)	(6) QTY
GROUP 04 ELECTRICAL					
FIG. 16 VENTILATING AIR MOTOR					
1	PAFZZ	96906	MS35206-281	SCREW,MACHINE PAN HEAD	4
2	PAFZZ	96906	MS45904-69	WASHER,LOCK INTERNAL TOOTH	4
3	PAFZZ	53711	5979393-1	SCREW,CAP,HEXAGON H HEXAGON HEAD,1/ 4-20 X 1 IN. LG	1
4	XBFZZ	92878	168231-01	MOUNTING BRACKET, CAPACITOR	1
5	PAFZH	96906	MS51967-2	NUT,PLAIN,HEXAGON	1
6	PAFZH	96906	MS35333-40	WASHER,LOCK INTERNAL TOOTH	1
7	XBFZZ	62119	9481	SCREW,ROUND HEAD, SELF TAPPING	1
8	XBFZZ	01002	614A527P21	BOOT,CAPACITOR	1
9	PAFZZ	01002	344X192 FB	CAPACITOR,FIXED,PAP	1
10	PAFZZ	53711	5979393-1	SCREW,CAP,HEXAGON H HEXAGON HEAD,1/ 4-20 X 1 IN. LG	1
11	PAFZH	96906	MS51967-2	NUT,PLAIN,HEXAGON	1
12	PAFZH	96906	MS35333-40	WASHER,LOCK INTERNAL TOOTH	1
13	XBFZZ	92878	168213	MOUNT,MOTOR	2
14	XBFZZ	60399	N-1016-3	FAN INCLUDES SET SCREW MS51964-65 (96906)	1
15	PAFZZ	96906	MS51964-65	SCREW, CUP POINT	2
16	PAFZZ	96906	MS21044-N08	NUT,SELF-LOCK,HE #8	4
17	PAFZZ	96906	MS35335-31	WASHER,LOCK EXTERNAL TOOTH	1
18	XBFZZ	92878	2-68827-01	STRAP,GROUND	1
19	PAFZZ	92878	168287	MOTOR,ALTERNATING C AIR	1
20	PAFZZ	59730	B14-250A	TERMINAL,QUICK DISC QUICK DISCONNECT	2
21	PAFZZ	14726	SO5076	TERMINAL,QUICK DISC	1
22	XDFZZ	00779	34070	SPLICE,CONDUCTOR 22-16 AWG	1
23	XBFRZZ	62119	PHIL	MOTOR,VENTILATING, AIR	1
24	XBFZZ	92878	168288	CUSHION,MOTOR	1

END OF FIGURE

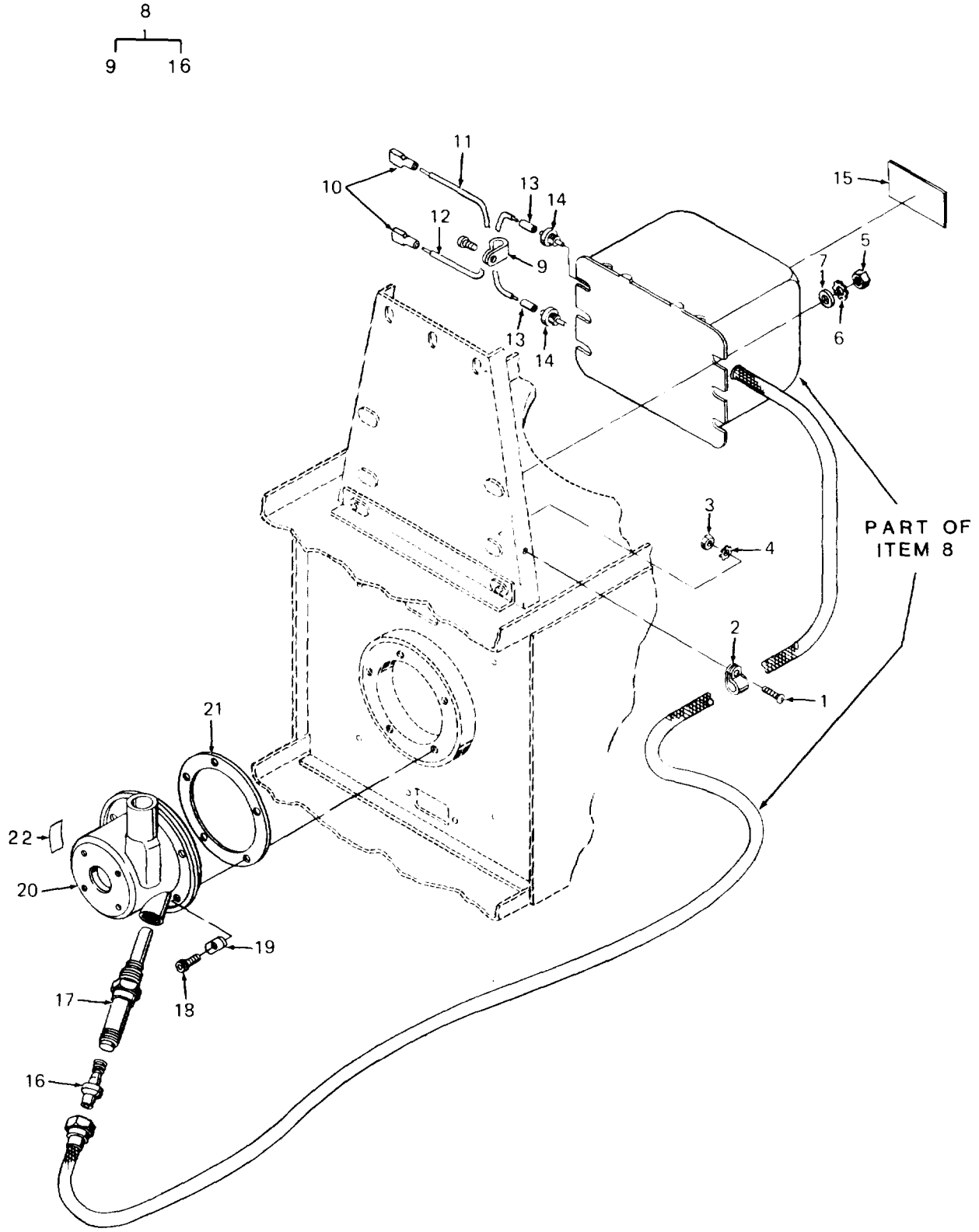

Figure 17. Burner Head and Transformer

SECTION II (1) ITEM NO	(2) SMR CODE	(3) FSCM	TM5-4520-253-23P (4) PART NUMBER	(5) DESCRIPTION AND USABLE ON CODE (UOC)	(6) QTY
GOUP 05 BURNER ASSEMBLY					
FIG. 17 BURNER HEAD AND TRANSFORMER					
1	PAOZZ	92878	2066	SCREW,MACHINE SLOTTED BINDER HEAD, #6-32 X9/16 IN. LG	1
2	PAOZZ	78553	C4886-S-5-24D	CLAMP,LOOP	1
3	PAOZZ	96906	MS35649-262	NUT,PLAIN,HEXAGON #6-32	1
4	PAOZZ	96906	MS35335-30	WASHER,LOCK EXTERNAL TOOTH,#6	1
5	PAOZZ	96906	MS51967-2	NUT,PLAIN,HEXAGON	4
6	PAOZZ	96906	MS35335-33	WASHER,LOCK EXTERNAL TOOTH	4
7	PAOZF	96906	MS27183-10	WASHER,FLAT	4
8	PAOZZ	92878	168202	TRANSFORMER,POWER,C ASSEMBLY INCLUDES HIGH VOLTAGE CABLE AND CONNECTOR	1
9	PAOZZ	78553	C-4980-A-4-35	CLAMP,LOOP	1
10	PAOZZ	14726	SO5076	TERMINAL,QUICK DISC	2
11	MOOZZ	92878	10781-37	WIRE,ELECTRICAL 16 GA.,WHITE,6 IN.LG.MFR.FROM P/ M16878/1BJE9 (81349)	1
12	MOOZZ	92878	10770-01	WIRE,ELECTRRICAL 16 GA.,YELLOW,6 IN.LG.MFR.FROM P/N M16878/1BJE4 (81349)	1
13	XBOZZ	91878	10725-02	SLEEVING	2
14	XBOZZ	33095	51-717-007 8503	FILTER,EMI	2
15	XBOZZ	92878	168315	LABEL	1
16	PAOZZ	92878	168706	CONNECTOR	1
17	PAOZZ	92878	2-168681	IGNITER, SPARK, FUEL	1
18	XDFZZ	92878	7521	SCREW SOCKET HEAD,#10-24 X1/2 IN. LG.,EVERLUBE FINISH	5
19	XBFFZ	92878	168680	PAD,PRESSURE	5
20	PBFZZ	928778	2-168627	BURNER HEAD UNIT ASSEMBLY	1
21	PBFZZ	92878	49093	GASKET	1
22	XBOZZ	92878	168685	DECAL,IGNITER	1

END OF FIGURE

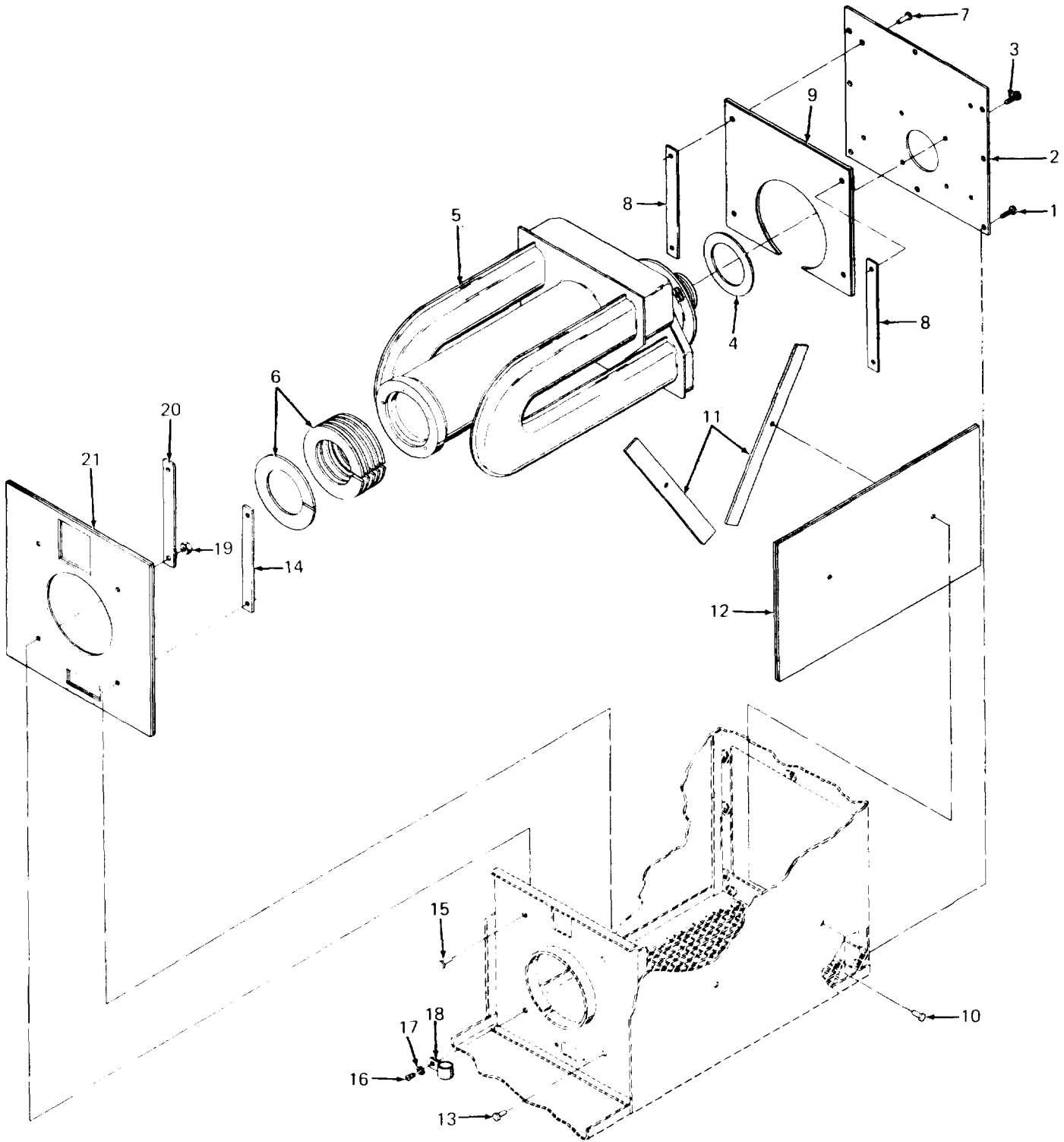

Figure 18. Heat Exchanger and Shields

SECTION II (1)	ITEM (2)	(3)	TM5-4520-253-23P (4)	(5)	(6)
NO	SMR CODE	FSCM	PART NUMBER	DESCRIPTION AND USABLE ON CODE (UOC)	QTY
GROUP 06 HEAT EXCHANGER					
FIG. 18 HEAT EXCHANGER AND SHIELDS					
1	PAFZZ	92878	3050	SCREW,SELF-LOCKING WITH LOCK WASHER	8
2	XBFZZ	92878	168025	EXCHANGER COVER, REAR	1
3	PAFZZ	92878	3050	SCREW,SELF-LOCKING WITH LOCK WASHER	4
4	PAFZZ	92878	68072	GASKET	1
5	PBZO	92878	2-168676	EXCHANGER,HEATER ASSEMBLY	1
6	XBFZZ	92878	168126	INSULATOR,HEAT EXCHANGER	6
7	PAFZZ	96906	MS20600-AD6W4	RIVET,BLIND STRUCTURAL PULL STEM	4
8	XBFZZ	92878	168248	STRAP,SUPPORT	2
9	XBFZZ	92878	168053	FELT,MECHANICAL,PRE	1
10	PAFZZ	96906	MS20600-AD6W4	RIVET,BLIND	4
11	XBFZZ	92878	168247	RETAINER,SHIELD	4
12	XBFZZ	92878	168052	SHIELD,HEATER CASE	2
13	PAFZZ	96906	MS20600-AD6W4	RIVET,BLIND STRUCTURAL PULL STEM	4
14	XBFZZ	92878	168248	STRAP,SUPPORT	2
15	PAFZZ	96906	MS20600-AD6W4	RIVET,BLIND STRUCTURAL PULL STEM	1
16	PAOZZ	96906	MS35206-263	SCREW,MACHINE PAN HEAD	1
17	PAOZZ	96906	MS35335-32	WASHER,LOCK EXTERNAL TOOTH	1
18	PAOZH	96906	MS21333-100	CLAMP,LOOP	1
19	PAOZZ	96906	MS35649-262	NUT,PLAIN,HEXAGON #6-32	1
20	XBFZZ	92878	168248	STRAP,SUPPORT	1
21	XBFZZ	92878	168229	INSULATION,SHIELD	1

END OF FIGURE

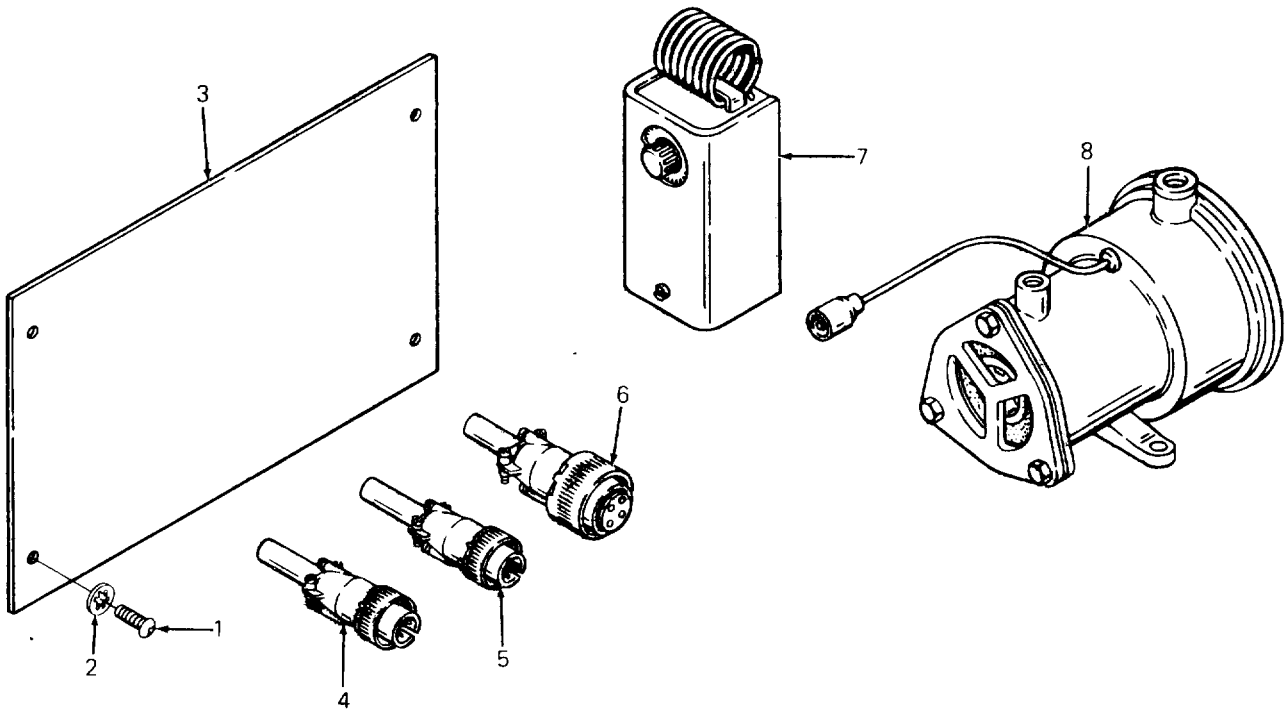

Figure 19. Accessories

SECTION II					
(1)	(2)	(3)	(4)	(5)	(6)
ITEM NO	SMR CODE	FSCM	PART NUMBER	DESCRIPTION AND USABLE ON CODE (UOC)	QTY
TM5-4520-253-23P					
GROUP 07 ACCESSORY ITEMS					
FIG. 19 ACCESSORIES					
1	PAOZO	96906	MS35206-261	SCREW,MACHINE PAN HEAD	8
2	PAOZZ	96906	MS35333-39	WASHER,LOCK INTERNAL TOOTH	8
3	ZBOZZ	92878	68635-07	COVER,SIDE, HEATER CASE	2
4	PAOZZ	96906	MS3456W14S7P	CONNECTOR,PLUG,ELEC ROOM THERMOSTAT	1
5	PAOZZ	96906	MS3106F14S-9P	CONNECTOR,PLUG,ELEC FUEL PUMP	1
6	XDOZZ	96906	MS3456W18-10S	CONNECTOR,PLUG, ELEC	1
7	XDOZZ	92578	A19BAE-1	SWITCH, THERMOSTATIC	1
8	PAOZF	96906	MS51321-1	PUMP,FUEL,ELECTICA	1
END OF FIGURE					

SECTION II		TM5-4520-253-23P			
(1)	(2)	(3)	(4)	(5)	(6)
ITEM NO	SMR CODE	FSCM	PART NUMBER	DESCRIPTION AND USABLE ON CODE (UOC)	QTY
GROUP 08 BULK					
1	PAOZZ	99974	MM3412	WIRE,ELECTRICAL	V
2	PAOZZ	99974	MM3412	WIRE,ELECTRICAL	V
3	XDOZZ	81349	M16878/1BGE8	WIRE,ELECTRICAL	V
4	PAOZZ	81349	M16878/1BJE4	WIRE,ELECTRICAL	V
5	PAOZZ	81349	M16878/1BGE4	WIRE,ELECTRICAL	V
6	XDOZZ	81349	M16878/1BJE1	WIRE,ELECTRICAL	V
7	XDOZZ	81349	M16878/1BJE1	WIRE,ELECTRICAL	V
8	PAOZZ	81349	M16878/1BJE0	WIRE,ELECTRICAL	V
9	PAOZZ	81349	M16878/1BGE9	WIRE,ELECTRICAL	V
10	PAOZZ	81349	M16878/1BGE3	WIRE,ELECTRICAL	V
11	XDOZZ	81349	M16878/1BJE2	WIRE,ELECTRICAL	V
12	XDOZZ	81349	M16878/1BGE8	WIRE,ELECTRICAL	V
13	PAOZZ	81349	M16878/1BGE3	WIRE,ELECTRICAL	V
14	XDOZZ	81349	M16878/1BJE3	WIRE,ELECTRICAL	V
15	PAOZZ	81349	M16878/1BGE5	WIRE,ELECTRICAL	V
16	PAOZZ	81349	M16878/1BGE5	WIRE,ELECTRICAL	V
17	PAFZZ	81349	M16878/1BJE4	WIRE,ELECTRICAL	V
18	PAFZZ	81349	M16878/1BJE9	WIRE,ELECTRICAL	V
19	PAFZZ	81349	M16878/4BJE0	WIRE,ELECTRICAL	V
20	PAOZZ	81349	M16878/1BJE9	WIRE,ELECTRICAL	V
21	PAOZZ	81349	M16878/1BJE4	WIRE,ELECTRICAL	V
22	PAOZZ	81349	M16878/1BGE7	WIRE,ELECTRICAL	V

END OF FIGURE

BULK-1

TM 5-4520-253-23P

SECTION III

Not Applicable

CROSS-REFERENCE INDEXES

NATIONAL STOCK NUMBER INDEX

STOCK NUMBER	FIG.	ITEM	STOCK NUMBER	FIG.	ITEM
5315-00-005-0442	6	5	5940-00-481-9089	16	20
5320-00-060-5385	7	4	4520-00-534-6826	12	5
	8	4	6145-00-542-6573	BULK	4
	9	15		BULK	17
	9	17		BULK	21
5310-00-067-6357	16	2	5310-00-550-1130	9	31
5305-00-068-0500	9	30		14	4
	9	34		16	6
	9	43		16	12
5305-00-068-0501	9	36	5310-00-559-0070	10	3
5305-00-068-0502	6	9		10	10
5305-00-071-2233	14	3		13	2
5975-00-074-2072	2	2		13	11
	3	2	5310-00-576-5752	9	3
	5	3		9	11
	14	19		9	22
5310-00-088-1251	6	11		9	28
5340-00-103-2900	17	2		9	47
6105-00-104-4341	14	20		14	16
5330-00-110-8745	18	4		14	22
5940-00-143-4780	5	16		19	2
	5	19	5310-00-579-0079	1	10
5330-00-166-0994	12	31		1	12
5975-00-201-8826	4	15		12	22
5940-00-204-8966	2	6		12	36
	2	9		13	5
	3	6		13	14
	5	33		14	9
5310-00-209-0786	9	35	5320-00-582-3276	18	7
	9	37		18	10
	9	44		18	13
	17	6		18	15
5310-00-209-0788	4	4	5310-00-596-7691	10	17
	4	21		18	17
	17	4	5310-00-596-7693	16	17
5325-00-276-4993	13	8	5930-00-615-9376	4	6
4730-00-278-3721	10	13	5310-00-616-3554	1	4
	12	16		1	8
5330-00-321-0982	12	8		4	25
5310-00-337-8329	4	10	4730-00-618-2952	10	6
	4	32	5935-00-626-3102	19	4
	7	3	6145-00-643-0650	BULK	18
	8	3		BULK	20
	9	6	6145-00-652-1441	BULK	9
	9	14	2910-00-652-4446	11	6
	9	25	6145-00-652-9307	BULK	5
6145-00-347-1171	BULK	19	5925-00-682-4015	4	17
6150-00-351-3424	9	38	2910-00-710-6054	19	8
5940-00-481-9089	2	14	5305-00-724-5812	16	15
	3	12	5325-00-726-6699	4	9

CROSS-REFERENCE INDEXES

NATIONAL STOCK NUMBER INDEX

STOCK NUMBER	FIG.	ITEM	STOCK NUMBER	FIG.	ITEM
5325-00-726-6699	7	2	5320-00-948-7332	4	12
	8	2		7	7
	9	5		8	7
	9	13	5320-00-956-5737	4	29
	9	24	4520-00-962-1048	12	11
5310-00-761-6882	16	5	5310-00-983-8483	6	2
	16	11	5305-00-984-4983	12	21
	17	5		12	35
4730-00-764-7353	10	5	5305-00-984-4984	1	9
	10	12		13	3
5340-00-809-1492	18	18		13	12
5310-00-809-4058	17	7	5305-00-984-4988	4	2
5310-00-811-3494	16	16	5305-00-984-6208	9	1
6145-00-822-1425	BULK	1		9	9
	BULK	2		9	20
5935-00-831-8733	3	5		9	27
5305-00-855-0957	14	21		9	46
5305-00-855-0972	14	8		19	1
5360-00-888-3289	6	7	5305-00-984-6210	14	15
5330-00-888-4991	11	5		18	16
5310-00-889-2528	9	41	5305-00-988-1725	16	1
5310-00-889-2708	4	23	5305-00-993-0190	4	26
5305-00-889-2997	1	1	5320-01-004-0238	9	50
	1	5	5935-01-014-3302	19	5
5305-00-889-3000	4	22	5305-01-085-3224	17	1
5305-00-889-3001	1	11	5930-01-085-3357	13	7
5305-00-889-3002	10	1		13	15
	10	8	5360-01-085-3509	6	3
	13	1	5935-01-085-4554	3	8
	13	10	4720-01-085-4988	14	2
2910-00-905-9792	22	1	5910-01-085-6434	14	14
4730-00-908-3194	14	1	4530-01-085-9215	17	20
5930-00-909-8586	12	23	5315-01-086-0602	6	1
5940-00-926-0085	2	13	5330-01-087-8827	12	30
	3	11	5330-01-087-8831	17	21
	5	6	4520-01-087-9511	17	17
	5	8	4710-01-088-7508	10	7
	5	12		10	15
5310-00-934-9739	1	3	6210-01-089-9866	4	7
	1	7	6210-01-093-3202	4	8
	4	24	5940-01-139-0853	12	18
5310-00-934-9747	4	3		12	25
	4	20		14	13
	13	4		16	21
	13	13		17	10
	17	3	5935-01-175-8419	1	2
	18	19	5935-01-181-6651	1	6
5310-00-934-9758	9	2	2910-01-206-8630	17	16
	9	10	4520-01-238-3801	14	7
	9	21	7690-01-241-7476	9	52

CROSS-REFERENCE INDEXES

NATIONAL STOCK NUMBER INDEX

STOCK NUMBER	FIG.	ITEM	STOCK NUMBER	FIG.	ITEM
7690-01-241-7477	9	53			
4520-01-242-1644	9	55			
4520-01-242-1645	10	2			
	10	9			
4520-01-242-1646	12	1			
4520-01-242-1647	12	17			
4520-01-242-1648	12	24			
5910-01-242-1658	16	9			
7690-01-242-1680	4	33			
7690-01-242-1681	4	34			
7690-01-242-1682	4	35			
5940-01-242-1706	9	40			
4520-01-242-7256	4	18			
5305-01-256-8504	16	3			
	16	10			
5935-01-305-2938	2	5			
5935-01-306-2380	23	8			
5305-01-306-9863	14	6			
	18	1			
	18	3			

CROSS-REFERENCE INDEXES

FSCM	PART NUMBER	PART NUMBER INDEX STOCK NUMBER	FIG.	ITEM
05624	AYRZ14	5325-00-276-4993	13	8
92578	A19BAE-1		19	7
19207	A5277290		11	2
59730	B14-250A	5940-00-481-9089	2	14
			3	12
			16	20
14726	B1870BNT		14	18
78553	C-4980-A-4-35		5	2
			17	9
78553	C4886-S-5-24D	5340-00-103-2900	17	2
62119	FHIL		16	23
79960	FIX38	5330-00-888-4991	11	5
79960	F10X3		11	3
79960	F2X79T3	2910-00-652-4446	11	6
79960	F7X184		11	7
79960	F8X56		11	4
99974	MM3412	6145-00-822-1425	BULK	1
			BULK	2
96906	MS16535-115	5320-00-948-7332	4	12
			7	7
			8	7
96906	MS16535-133	5320-00-060-5385	7	4
			8	4
			9	15
			9	17
96906	MS16535-54	5320-00-956-5737	4	29
96906	MS20600-AD6W4	5320-00-582-3276	18	7
			18	10
			18	13
			18	15
96906	MS21044-N08	5310-00-811-3494	16	16
96906	MS21333-100	5340-00-809-1492	18	18
96906	MS24629-23	5305-00-855-0972	14	8
96906	MS24629-46	5305-00-855-0957	14	21
96906	MS24665-285	5315-00-005-0442	6	5
96906	MS25036-102	5940-00-204-8966	2	6
			2	9
			3	6
			5	33
96906	MS25036-108	5940-00-143-4780	5	16
			5	19
96906	MS25043-14DA	5935-01-181-6651	1	6
96906	MS25043-18DA	5935-01-175-8419	1	2
96906	MS25244-20	5925-00-682-4015	4	17
96906	MS27183-10	5310-00-809-4058	17	7
96906	MS27183-5	5310-00-983-8483	6	2
96906	MS3100R-14S-7S		5	29
96906	MS3100R-14S-9S	5935-00-831-8733	3	5
96906	MS3103-14S-9S	5935-01-305-2938	2	5
96906	MS3103-14S7S		5	28
96906	MS3103-18-10P	5935-01-306-2380	2	8

CROSS-REFERENCE INDEXES

FSCM	PART NUMBER	PART NUMBER INDEX STOCK NUMBER	FIG.	ITEM
96906	MS3106F14S-9P	5935-01-014-3302	19	5
96906	MS3367-1-9	5975-00-074-2072	2	2
			3	2
			5	3
			14	19
96906	MS3450W18-10P	5935-01-085-4554	3	8
96906	MS3456W14S7P	5935-00-626-3102	19	4
96906	MS3456W18-10S		19	6
96906	MS35059-21	5930-00-615-9376	4	6
96906	MS35206-214	5305-00-993-0190	4	26
96906	MS35206-215	5305-00-889-2997	1	1
			1	5
96906	MS35206-226	5305-00-984-4983	12	21
			12	35
96906	MS35206-227	5305-00-984-4984	1	9
			13	3
			13	12
96906	MS35206-228	5305-00-984-4988	4	2
96906	MS35206-230	5305-00-889-3000	4	22
96906	MS35206-231	5305-00-889-3001	1	11
96906	MS35206-242	5305-00-889-3002	10	1
			10	8
			13	1
			13	10
96906	MS35206-261	5305-00-984-6208	9	1
			9	9
			9	20
			9	27
			9	46
			19	1
96906	MS35206-263	5305-00-984-6210	14	15
			18	16
96906	MS35206-281	5305-00-988-1725	16	1
96906	MS35333-37	5310-00-579-0079	1	10
			1	12
			12	22
			12	36
			13	5
			13	14
			14	9
96906	MS35333-38	5310-00-559-0070	10	3
			10	10
			13	2
			13	11
96906	MS35333-39	5310-00-576-5752	9	3
			9	11
			9	22
			9	28
			9	47
			14	16
			14	22

CROSS-REFERENCE INDEXES

FSCM	PART NUMBER	PART NUMBER INDEX STOCK NUMBER	FIG.	ITEM
96906	MS35333-39	5310-00-576-5752	19	2
96906	MS35333-40	5310-00-550-1130	9	31
			14	4
			16	6
			16	12
96906	MS35335-29	5310-00-616-3554	1	4
			1	8
			4	25
96906	MS35335-30	5310-00-209-0788	4	4
			4	21
			17	4
96906	MS35335-31	5310-00-596-7693	16	17
96906	MS35335-32	5310-00-596-7691	10	17
			18	17
96906	MS35335-33	5310-00-209-0786	9	35
			9	37
			9	44
			17	6
96906	MS35649-202	5310-00-934-9758	9	2
			9	10
			9	21
96906	MS35649-242	5310-00-934-9739	1	3
			1	7
			4	24
96906	MS35649-262	5310-00-934-9747	4	3
			4	20
			13	4
			13	13
			17	3
			18	19
96906	MS35842-11	4730-00-908-3194	14	1
96906	MS45904-54	5310-00-889-2708	4	23
96906	MS45904-68	5310-00-889-2528	9	41
96906	MS45904-69	5310-00-067-6357	16	2
96906	MS51086-1	2910-00-905-9792	11	1
96906	MS51321-1	2910-00-710-6054	19	8
96906	MS51922-1	5310-00-088-1251	6	11
96906	MS51964-65	5305-00-724-5812	16	15
96906	MS51967-2	5310-00-761-6882	16	5
			16	11
			17	5
96906	MS9021-005		12	26
96906	MS90725-18	5305-00-071-2233	14	3
96906	MS90725-3	5305-00-068-0500	9	30
			9	34
			9	43
96906	MS90725-5	5305-00-068-0501	9	36
96906	MS90725-6	5305-00-068-0502	6	9
81349	M16878/1BGE3		BULK	10
			BULK	13
81349	M16878/1BGE4	6145-00-652-9307	BULK	5

CROSS-REFERENCE INDEXES

FSCM	PART NUMBER	PART NUMBER INDEX STOCK NUMBER	FIG.	ITEM
81349	M16878/1BGE5		BULK	15
			BULK	16
81349	M16878/1BGE7		BULK	22
81349	M16878/1BGE8		BULK	3
			BULK	12
81349	M16878/1BGE9	6145-00-652-1441	BULK	9
81349	M16878/1BJE0		BULK	8
81349	M16878/1BJE1		BULK	6
			BULK	7
81349	M16878/1BJE2		BULK	11
81349	M16878/1B4E3		BULK	14
81349	M16878/1BJE4	6145-00-542-6573	BULK	4
			BULK	17
			BULK	21
81349	M16878/1BJE9	6145-00-643-0650	BULK	18
			BULK	20
81349	M16878/4BJE0	6145-00-347-1171	BULK	19
92878	M4080		15	15
92878	M4081		15	16
			15	19
92878	M4084		15	10
92878	M4085		15	17
92878	M4091-1		15	18
92878	M4092		15	17
92878	M4094		15	7
92878	M4095		15	20
92878	M4349-3		15	9
92878	M4386-4		15	5
92878	M4402		15	3
92878	M4406-1		15	4
92878	M4417-1		15	14
92878	M4418		15	6
92878	M4423-4		15	12
81349	M83248/1-018	5330-00-166-0994	12	31
06402	N 1 480 08	4520-01-242-7256	4	18
60399	N-1016-3		16	14
14726	R3458BT		9	39
10054	SB4-2	5320-01-004-0238	9	50
01692	SC37178		12	20
14726	SO5075		2	11
			3	9
14726	SO5076	5940-01-139-0853	12	18
			12	25
			14	13
			16	21
			17	10
14726	SO5363SFT		2	12
			3	10
			12	19
14726	SO9718SF	5940-00-926-0085	2	13
			3	11

CROSS-REFERENCE INDEXES

FSCM	PART NUMBER	PART NUMBER INDEX STOCK NUMBER	FIG.	ITEM
14726	S09718SF	5940-00-926-0085	5	6
			5	8
			5	12
96152	012641		12	14
96152	012642		12	12
96152	012643		12	13
96152	013440		12	4
96152	013441		12	10
96152	013443	4520-00-962-1048	12	11
27264	03-09-2092		3	14
			5	4
96152	0700		12	9
96152	07397		12	7
96152	07398	5330-00-321-0982	12	8
96152	09196		12	15
59501	10-17966		12	3
92878	10534-01	5940-01-242-1706	9	40
92878	10662-03	4710-01-088-7508	10	7
			10	15
92878	10725-02		17	13
92878	10736-02		5	27
92878	10736-06		5	24
92878	10739-03		5	13
			5	14
92878	10766-12		5	30
92878	10767-05		5	18
92878	10767-09		5	17
92878	10768-12		2	7
			2	10
			3	7
92878	10770-01		17	12
92878	10770-23		5	9
			14	11
92878	10772-11		5	20
92878	10774-30		5	25
92878	10781-12		14	12
92878	10781-37		17	11
92878	10782-13		5	22
92878	10785-01		5	31
92878	10785-03		5	32
92878	10795-03		5	10
92878	10799		5	7
92878	10799-06		5	26
92878	10895-03		15	2
12204	117957		13	16
27264	1189-02-09-1103		2	4
			3	4
27264	1190-02-09-2103		3	13
			5	5
70485	1418		9	49
92878	168018		9	42

CROSS-REFERENCE INDEXES

FSCM	PART NUMBER	PART NUMBER INDEX STOCK NUMBER	FIG.	ITEM
92878	168025		18	2
92878	168046		4	27
92878	168052		18	12
92878	168053		18	9
92878	168059	7690-01-241-7476	9	52
92878	168102	4520-01-242-1645	10	2
			10	9
92878	168126		18	6
92878	168148		8	8
92878	168149		7	8
92878	168156	7690-01-242-1681	4	34
92878	168161	4520-01-238-3801	14	7
92878	168162		14	10
92878	168192		14	17
92878	168194		14	23
92878	168198	4520-01-242-1646	12	1
92878	168199		12	38
92878	168202		17	8
92878	168204	4520-01-242-1648	12	24
92878	168213		16	13
92878	168216		4	1
92878	168217		4	28
92878	168218		4	5
92878	168225		5	1
92878	168227		1	13
92878	168229		18	21
92878	168230		8	10
92878	168231-01		16	4
92878	168232		8	1
92878	168233		7	10
92878	168235		7	1
92878	168241		9	4
92878	168242		9	8
92878	168244-01		10	11
92878	168244-02		10	4
92878	168247		18	11
92878	168248		18	8
			18	14
			18	20
92878	168249		4	36
92878	168252		9	16
92878	168253		9	19
92878	168255		9	12
92878	168257		2	1
92878	16825701		3	1
92878	168263	4520-01-242-1647	12	17
92878	168271		4	14
92878	168287		16	19
92878	168288		16	24
92878	168289		13	17
92878	168294		14	5

CROSS-REFERENCE INDEXES

FSCM	PART NUMBER	PART NUMBER INDEX STOCK NUMBER	FIG.	ITEM
92878	168296		9	18
92878	168299		9	48
92878	168315		17	15
92878	168524	7690-01-242-1682	4	35
92878	168530		4	11
			9	7
92878	168615		15	8
			15	13
92878	168679		12	33
92878	168680		17	19
92878	168685		17	22
92878	168686		13	6
92878	168706	2910-01-206-8630	17	16
20832	17C0171-3		12	27
92878	170559		9	51
92878	170816	5910-01-085-6434	14	14
92878	2-168006		9	23
92878	2-168111		9	45
92878	2-168195		9	54
92878	2-168559		13	9
92878	2-168627	4530-01-085-9215	17	20
92878	2-168667		15	1
92878	2-168676		18	5
92878	2-168681	4520-01-087-9511	17	17
92878	2-48113-02		12	32
92878	2-68619		9	26
92878	2-68746		8	6
92878	2-68756		7	6
92878	2-68827-01		16	18
92878	2-68828	6150-00-351-3424	9	38
92878	2066	5305-01-085-3224	17	1
71286	212-12B-R		4	30
65029	26	5315-01-086-0602	6	1
71286	26R41-1-1AA	4520-01-242-1644	9	55
71286	26S8-2		4	31
71286	26S8-3	5325-00-726-6699	4	9
			7	2
			8	2
			9	5
			9	13
			9	24
71286	2600-LW	5310-00-337-8329	4	10
			4	32
			7	3
			9	6
			9	14
			9	25
92878	3050	5305-01-306-9863	14	6
			18	1
			18	3

CROSS-REFERENCE INDEXES

FSCM	PART NUMBER	PART NUMBER INDEX STOCK NUMBER	FIG.	ITEM
79470	3325X2	4730-00-278-3721	10	13
			12	16
00779	34070		5	11
			5	15
			5	21
			5	23
			16	22
01002	344X192 FB	5910-01-242-1658	16	9
81349	36T21	5930-01-085-3357	13	7
			13	15
13499	372-5909-720		2	3
			3	3
30780	4CB12B		10	14
			12	2
97539	4082	5975-00-201-8826	4	15
06402	45-700-IG1-P10-A 3-010		4	19
19207	454430		12	6
92878	47172		6	6
92878	47907		12	28
92878	49032		12	37
92878	49093	5330-01-087-8831	17	21
92878	49189		12	29
92878	49323		12	33
92878	49351-02	4720-01-085-4988	14	2
33095	51-717-007 8503		17	14
92878	5357	5930-00-909-8586	12	23
92878	5621	6105-00-104-4341	14	20
27877	568-006	5330-01-087-8827	12	30
92878	58620		9	33
92878	58621		9	32
53711	5979393-1	5305-01-256-8504	16	3
			16	10
01002	614A527P21		16	8
92878	65838		6	10
93061	68CA-4-2	4730-00-618-2952	10	6
92878	68072	5330-00-110-8745	18	4
92878	68313		4	13
92878	68330	4730-00-764-7353	10	5
			10	12
92878	68635-07		19	3
92878	68662-01		6	4
92878	68671-01		6	8
92878	68706		9	29
92878	68708-02	7690-01-241-7477	9	53
92878	68708-05	7690-01-242-1680	4	33
92878	68711	5360-01-085-3509	6	3
92878	68748		7	9
			8	9
92878	68751		8	5
92878	68754		6	12

CROSS-REFERENCE INDEXES

FSCM	PART NUMBER	PART NUMBER INDEX STOCK NUMBER	FIG.	ITEM
92878	68761		7	5
97539	7		4	16
55292	700-1-10-RA9X	6210-01-093-3202	4	8
55292	700-1-7-RA9X	6210-01-089-9866	4	7
92878	7520		10	16
92878	7521		17	18
24658	80861-45	5360-00-888-3289	6	7
62119	9481		16	7
96152	95-164	4520-00-534-6826	12	5

CROSS-REFERENCE INDEXES

FIG.	ITEM	FIGURE AND ITEM NUMBER INDEX		PART NUMBER
		STOCK NUMBER	FSCM	
BULK	1	6145-00-822-1425	99974	MM3412
BULK	2	6145-00-822-1425	99974	MM3412
BULK	3		81349	M16878/1BGE8
BULK	4	6145-00-542-6573	81349	M16878/1BJE4
BULK	5	6145-00-652-9307	81349	M16878/1BGE4
BULK	6		81349	M16878/1BJE1
BULK	7		81349	M16878/1BJE1
BULK	8		81349	M16878/1BJE0
BULK	9	6145-00-652-1441	81349	M16878/1BGE9
BULK	10		81349	M16878/1BGE3
BULK	11		81349	M16878/1BJE2
BULK	12		81349	M16878/1BGE8
BULK	13		81349	M16878/1BGE3
BULK	14		81349	M16878/1BJE3
BULK	15		81349	M16878/1BGE5
BULK	16		81349	M16878/1BGE5
BULK	17	6145-00-542-6573	81349	M16878/1BJE4
BULK	18	6145-00-643-0650	81349	M16878/1BJE9
BULK	19	6145-00-347-1171	81349	M16878/4BJE0
BULK	20	6145-00-643-0650	81349	M16878/1BJE9
BULK	21	6145-00-542-6573	81349	M16878/1BJE4
BULK	22		81349	M16878/1BGE7
1	1	5305-00-889-2997	96906	MS35206-215
1	2	5935-01-175-8419	96906	MS25043-18DA
1	3	5310-00-934-9739	96906	MS35649-242
1	4	5310-00-616-3554	96906	MS35335-29
1	5	5305-00-889-2997	96906	MS35206-215
1	6	5935-01-181-6651	96906	MS25043-14DA
1	7	5310-00-934-9739	96906	MS35649-242
1	8	5310-00-616-3554	96906	MS35335-29
1	9	5305-00-984-4984	96906	MS35206-227
1	10	5310-00-579-0079	96906	MS35333-37
1	11	5305-00-889-3001	96906	MS35206-231
1	12	5310-00-579-0079	96906	MS35333-37
1	13		92878	168227
2	1		92878	168257
2	2	5975-00-074-2072	96906	MS3367-1-9
2	3		13499	372-5909-720
2	4		27264	1189-02-09-1103
2	5	5935-01-305-2938	96906	MS3103-14S-9S
2	6	5940-00-204-8966	96906	MS25036-102
2	7		92878	10768-12
2	8	5935-01-306-2380	96906	MS3103-18-10P
2	9	5940-00-204-8966	96906	MS25036-102
2	10		92878	10768-12
2	11		14726	S05075
2	12		14726	S05363SFT
2	13	5940-00-926-0085	14726	S09718SF
2	14	5940-00-481-9089	59730	B14-250A
3	1		92878	16825701
3	2	5975-00-074-2072	96906	MS3367-1-9

CROSS-REFERENCE INDEXES

FIG.	ITEM	FIGURE AND ITEM NUMBER INDEX		PART NUMBER
		STOCK NUMBER	FSCM	
3	3		13499	372-5909-720
3	4		27264	1189-02-09-1103
3	5	5935-00-831-8733	96906	MS3100R-14S-9S
3	6	5940-00-204-8966	96906	MS25036-102
3	7		92878	10768-12
3	8	5935-01-085-4554	96906	MS3450W18-10P
3	9		14726	S05075
3	10		14726	S05363SFT
3	11	5940-00-926-0085	14726	S09718SF
3	12	5940-00-481-9089	59730	B14-250A
3	13		27264	1190-02-09-2103
3	14		27264	03-09-2092
4	1		92878	168216
4	2	5305-00-984-4988	96906	MS35206-228
4	3	5310-00-934-9747	96906	MS35649-262
4	4	5310-00-209-0788	96906	MS35335-30
4	5		92878	168218
4	6	5930-00-615-9376	96906	MS35059-21
4	7	6210-01-089-9866	55292	700-1-7-RA9X
4	8	6210-01-093-3202	55292	700-1-10-RA9X
4	9	5325-00-726-6699	71286	26S8-3
4	10	5310-00-337-8329	71286	2600-LW
4	11		92878	168530
4	12	5320-00-948-7332	96906	MS16535-115
4	13		92878	68313
4	14		92878	168271
4	15	5975-00-201-8826	97539	4082
4	16		97539	7
4	17	5925-00-682-4015	96906	MS25244-20
4	18	4520-01-242-7256	06402	N 1 480 08
4	19		06402	45-700-IG1-P10-A 3-010
4	20	5310-00-934-9747	96906	MS35649-262
4	21	5310-00-209-0788	96906	MS35335-30
4	22	5305-00-889-3000	96906	MS35206-230
4	23	5310-00-889-2708	96908	MS45904-54
4	24	5310-00-934-9739	96906	MS35649-242
4	25	5310-00-616-3554	96906	MS35335-29
4	26	5305-00-993-0190	96906	MS35206-214
4	27		92878	168046
4	28		92878	168217
4	29	5320-00-956-5737	96906	MS16535-54
4	30		71286	212-12B-R
4	31		71286	26S8-2
4	32	5310-00-337-8329	71286	2600-LW
4	33	7690-01-242-1680	92878	68708-05
4	34	7690-01-242-1681	92878	168156
4	35	7690-01-242-1682	92878	168524
4	36		92878	168249
5	1		92878	168225
5	2		78553	C-4980-A-4-35

CROSS-REFERENCE INDEXES

FIG.	ITEM	FIGURE AND ITEM NUMBER INDEX		PART NUMBER
		STOCK NUMBER	FSCM	
5	3	5975-00-074-2072	96906	MS3367-1-9
5	4		27264	03-09-2092
5	5		27264	1190-02-09-2103
5	6	5940-00-926-0085	14726	S09718SF
5	7		92878	10799
5	8	5940-00-926-0085	14726	S09718SF
5	9		92878	10770-23
5	10		92878	10795-03
5	11		00779	34070
5	12	5940-00-926-0085	14726	S09718SF
5	13		92878	10739-03
5	14		92878	10739-03
5	15		00779	34070
5	16	5940-00-143-4780	96906	MS25036-108
5	17		92878	10767-09
5	18		92878	10767-05
5	19	5940-00-143-4780	96906	MS25036-108
5	20		92878	10772-11
5	21		00779	34070
5	22		92878	10782-13
5	23		00779	34070
5	24		92878	10736-06
5	25		92878	10774-30
5	26		92878	10799-06
5	27		92878	10736-02
5	28		96906	MS3103-14S7S
5	29		96906	MS3100R-14S-7S
5	30		92878	10766-12
5	31		92878	10785-01
5	32		92878	10785-03
5	33	5940-00-204-8966	96906	MS25036-102
6	1	5315-01-086-0602	65029	26
6	2	5310-00-983-8483	96906	MS27183-5
6	3	5360-01-085-3509	92878	68711
6	4		92878	68662-01
6	5	5315-00-005-0442	96906	MS24665-285
6	6		92878	47172
6	7	5360-00-888-3289	24658	80861-45
6	8		92878	68671-01
6	9	5305-00-068-0502	96906	MS90725-6
6	10		92878	65838
6	11	5310-00-088-1251	96906	MS51922-1
6	12		92878	68754
7	1		92878	168235
7	2	5325-00-726-6699	71286	26S8-3
7	3	5310-00-337-8329	71286	2600-LW
7	4	5320-00-060-5385	96906	MS16535-133
7	5		92878	68761
7	6		92878	2-68756
7	7	5320-00-948-7332	96906	MS16535-115
7	8		92878	168149

CROSS-REFERENCE INDEXES

FIG.	ITEM	FIGURE AND ITEM NUMBER INDEX		PART NUMBER
		STOCK NUMBER	FSCM	
7	9		92878	68748
7	10		92878	168233
8	1		92878	168232
8	2	5325-00-726-6699	71286	26S8-3
8	3	5310-00-337-8329	71286	2600-LW
8	4	5320-00-060-5385	96906	MS16535-133
8	5		92878	68751
8	6		92878	2-68746
8	7	5320-00-948-7332	96906	MS16535-115
8	8		92878	168148
8	9		92878	68748
8	10		92878	168230
9	1	5305-00-984-6208	96906	MS35206-261
9	2	5310-00-934-9758	96906	MS35649-202
9	3	5310-00-576-5752	96906	MS35333-39
9	4		92878	168241
9	5	5325-00-726-6699	71286	26S8-3
9	6	5310-00-337-8329	71286	2600-LW
9	7		92878	168530
9	8		92878	168242
9	9	5305-00-984-6208	96906	MS35206-261
9	10	5310-00-934-9758	96906	MS35649-202
9	11	5310-00-576-5752	96906	MS35333-39
9	12		92878	168255
9	13	5325-00-726-6699	71286	26S8-3
9	14	5310-00-337-8329	71286	2600-LW
9	15	5320-00-060-5385	96906	MS16535-133
9	16		92878	168252
9	17	5320-00-060-5385	96906	MS16535-133
9	18		92878	168296
9	19		92878	168253
9	20	5305-00-984-6208	96906	MS35206-261
9	21	5310-00-934-9758	9696	MS35649-202
9	22	5310-00-576-5752	96906	MS35333-39
9	23		92878	2-168006
9	24	5325-00-726-6699	71286	26S8-3
9	25	5310-00-337-8329	71286	2600-LW
9	26		92878	2-68619
9	27	5305-00-984-6208	96906	MS35206-261
9	28	5310-00-576-5752	96906	MS35333-39
9	29		92878	68706
9	30	5305-00-068-0500	96906	MS90725-3
9	31	5310-00-550-1130	96906	MS35333-40
9	32		92878	58621
9	33		92878	58620
9	34	5305-00-068-0500	96906	MS90725-3
9	35	5310-00-209-0786	96906	MS35335-33
9	36	5305-00-068-0501	96906	MS90725-5
9	37	5310-00-209-0786	96906	MS35335-33
9	38	6150-00-351-3424	92878	2-68828
9	39		14726	R3458BT

CROSS-REFERENCE INDEXES

FIG.	ITEM	FIGURE AND ITEM NUMBER INDEX		PART NUMBER
		STOCK NUMBER	FSCM	
9	40	5940-01-242-1706	92878	10534-01
9	41	5310-00-889-2528	96906	MS45904-68
9	42		92878	168018
9	43	5305-00-068-0500	96906	MS90725-3
9	44	5310-00-209-0786	96906	MS35335-33
9	45		92878	2-168111
9	46	5305-00-984-6208	96906	MS35206-261
9	47	5310-00-576-5752	96906	MS35333-39
9	48		92878	168299
9	49		70485	1418
9	50	5320-01-004-0238	10054	SB4-2
9	51		92878	170559
9	52	7690-01-241-7476	92878	168059
9	53	7690-01-241-7477	92878	68708-02
9	54		92878	2-168195
9	55	4520-01-242-1644	71286	26R41-1-1AA
10	1	5305-00-889-3002	96906	MS35206-242
10	2	4520-01-242-1645	92878	168102
10	3	5310-00-559-0070	96906	MS35333-38
10	4		92878	168244-02
10	5	4730-00-764-7353	92878	68330
10	6	4730-00-618-2952	93061	68CA-4-2
10	7	4710-01-088-7508	92878	10662-03
10	8	5305-00-889-3002	96906	MS35206-242
10	9	4520-01-242-1645	92878	168102
10	10	5310-00-559-0070	96906	MS35333-38
10	11		92878	168244-01
10	12	4730-00-764-7353	92878	68330
10	13	4730-00-278-3721	79470	3325X2
10	14		30780	4CB12B
10	15	4710-01-088-7508	92878	10662-03
10	16		92878	7520
10	17	5310-00-596-7691	96906	MS35335-32
11	1	2910-00-905-9792	96906	MS51086-1
11	2		19207	A5277290
11	3		79960	F10X3
11	4		79960	F8X56
11	5	5330-00-888-4991	79960	FIX38
11	6	2910-00-652-4446	79960	F2X79T3
11	7		79960	F7X184
12	1	4520-01-242-1646	92878	168198
12	2		30780	4CB12B
12	3		59501	10-17966
12	4		96152	013440
12	5	4520-00-534-6826	96152	95-164
12	6		19207	454430
12	7		96152	07397
12	8	5330-00-321-0982	96152	07398
12	9		96152	0700
12	10		96152	013441
12	11	4520-00-962-1048	96152	013443

CROSS-REFERENCE INDEXES

FIG.	ITEM	FIGURE AND ITEM NUMBER INDEX		PART NUMBER
		STOCK NUMBER	FSCM	
12	12		96152	012642
12	13		96152	012643
12	14		96152	012641
12	15		96152	09196
12	16	4730-00-278-3721	79470	3325X2
12	17	4520-01-242-1647	92878	168263
12	18	5940-01-139-0853	14726	S05076
12	19		14726	S05363SFT
12	20		01692	SC37178
12	21	5305-00-984-4983	96906	MS35206-226
12	22	5310-00-579-0079	96906	MS35333-37
12	23	5930-00-909-8586	92878	5357
12	24	4520-01-242-1648	92878	168204
12	25	5940-01-139-0853	14726	S05076
12	26		96906	MS9021-005
12	27		20832	17C0171-3
12	28		92878	47907
12	29		92878	49189
12	30	5330-01-087-8827	27877	568-006
12	31	5330-00-166-0994	81349	M83248/1-018
12	32		92878	2-48113-02
12	33		92878	168679
12	33		92878	49323
12	35	5305-00-984-4983	96906	MS35206-226
12	36	5310-00-579-0079	96906	MS35333-37
12	37		92878	49032
12	38		92878	168199
13	1	5305-00-889-3002	96906	MS35206-242
13	2	5310-00-559-0070	96906	MS35333-38
13	3	5305-00-984-4984	96906	MS35206-227
13	4	5310-00-934-9747	96906	MS35649-262
13	5	5310-00-579-0079	96906	MS35333-37
13	6		92878	168686
13	7	5930-01-085-3357	81439	36T21
13	8	5325-00-276-4993	05624	AYRZ14
13	9		92878	2-168559
13	10	5305-00-889-3002	96906	MS35206-242
13	11	5310-00-559-0070	96906	MS35333-38
13	12	5305-00-984-4984	96906	MS35206-227
13	13	5310-00-934-9747	96906	MS35649-262
13	14	5310-00-579-0079	96906	MS35333-37
13	15	5930-01-085-3357	81439	36T21
13	16		12204	117957
13	17		92878	168289
14	1	4730-00-908-3194	96906	MS35842-11
14	2	4720-01-085-4988	92878	49351-02
14	3	5305-00-071-2233	96906	MS90725-18
14	4	5310-00-550-1130	96906	MS35333-40
14	5		92878	168294
14	6	5305-01-306-9863	92878	3050
14	7	4520-01-238-3801	92878	168161

CROSS-REFERENCE INDEXES

FIG.	ITEM	FIGURE AND ITEM NUMBER INDEX		PART NUMBER
		STOCK NUMBER	FSCM	
14	8	5305-00-855-0972	96906	MS24629-23
14	9	5310-00-579-0079	96906	MS35333-37
14	10		92878	168162
14	11		92878	10770-23
14	12		92878	10781-12
14	13	5940-01-139-0853	14726	S05076
14	14	5910-01-085-6434	92878	170816
14	15	5305-00-984-6210	96906	MS35206-263
14	16	5310-00-576-5752	96906	MS35333-39
14	17		92878	168192
14	18		14726	B1870BNT
14	19	5975-00-074-2072	96906	MS3367-1-9
14	20	6105-00-104-4341	92878	5621
14	21	5305-00-855-0957	96906	MS24629-46
14	22	5310-00-576-5752	96906	MS35333-39
14	23		92878	168194
15	1		92878	2-168667
15	2		92878	10895-03
15	3		92878	M4402
15	4		92878	M4406-1
15	5		92878	M4386-4
15	6		92878	M4418
15	7		92878	M4094
15	8		92878	168615
15	9		92878	M4349-3
15	10		92878	M4084
15	11		92878	M4085
15	12		92878	M4423-4
15	13		92878	168615
15	14		92878	M4417-1
15	15		92878	M4080
15	16		92878	M4081
15	17		92878	M4092
15	18		92878	M4091-1
15	19		92878	M4081
15	20		92878	M4095
16	1	5305-00-988-1725	96906	MS35206-281
16	2	5310-00-067-6357	96906	MS45904-69
16	3	5305-01-256-8504	53711	5979393-1
16	4		92878	168231-01
16	5	5310-00-761-6882	96906	MS51967-2
16	6	5310-00-550-1130	96906	MS35333-40
16	7		62119	9481
16	8		01002	614A527P21
16	9	5910-01-242-1658	01002	344X192 FB
16	10	5305-01-256-8504	53711	5979393-1
16	11	5310-00-761-6882	96906	MS51967-2
16	12	5310-00-550-1130	96906	MS35333-40
16	13		92878	168213
16	14		60399	N-1016-3
16	15	5305-00-724-5812	96906	MS51964-65

CROSS-REFERENCE INDEXES

FIG.	ITEM	FIGURE AND ITEM NUMBER INDEX		PART NUMBER
		STOCK NUMBER	FSCM	
16	16	5310-00-811-3494	96906	MS21044-N08
16	17	5310-00-596-7693	96906	MS35335-31
16	18		92878	2-68827-01
16	19		92878	168287
16	20	5940-00-481-9089	59730	B14-250A
16	21	5940-01-139-0853	14726	SO5076
16	22		00779	34070
16	23		62119	FHIL
16	24		92878	168288
17	1	5305-01-085-3224	92878	2066
17	2	5340-00-103-2900	78553	C4886-S-5-24D
17	3	5310-00-934-9747	96906	MS35649-262
17	4	5310-00-209-0788	96906	MS35335-30
17	5	5310-00-761-6882	96906	MS51967-2
17	6	5310-00-209-0786	96906	MS35335-33
17	7	5310-00-809-4058	96906	MS27183-10
17	8		92878	168202
17	9		78553	C-4980-A-4-35
17	10	5940-01-139-0853	14726	SO5076
17	11		92878	10781-37
17	12		92878	10770-01
17	13		92878	10725-02
17	14		33095	51-717-007 8503
17	15		92878	168315
17	16	2910-01-206-8630	92878	168706
17	17	4520-01-087-9511	92878	2-168681
17	18		92878	7521
17	19		92878	168680
17	20	4530-01-085-9215	92878	2-168627
17	21	5330-01-087-8831	92878	49093
17	22		92878	168685
18	1	5305-01-306-9863	92878	3050
18	2		92878	168025
18	3	5305-01-306-9863	92878	3050
18	4	5330-00-110-8745	92878	68072
18	5		92878	2-168676
18	6		92878	168126
18	7	5320-00-582-3276	96906	MS20600-AD6W4
18	8		92878	168248
18	9		92878	168053
18	10	5320-00-582-3276	96906	MS20600-AD6W4
18	11		92878	168247
18	12		92878	168052
18	13	5320-00-582-3276	96906	MS20600-AD6W4
18	14		92878	168248
18	15	5320-00-582-3276	96906	MS20600-AD6W4
18	16	5305-00-984-6210	96906	MS35206-263
18	17	5310-00-596-7691	96906	MS35335-32
18	18	5340-00-809-1492	96906	MS21333-100
18	19	5310-00-934-9747	96906	MS35649-262
18	20		92878	168248

CROSS-REFERENCE INDEXES

FIG.	ITEM	FIGURE AND ITEM NUMBER INDEX		PART NUMBER
		STOCK NUMBER	FSCM	
18	21		92878	168229
19	1	5305-00-984-6208	96906	MS35206-261
19	2	5310-00-576-5752	96906	MS35333-39
19	3		92878	68635-07
19	4	5935-00-626-3102	96906	MS3456W14S7P
19	5	5935-01-014-3302	96906	MS3106F14S-9P
19	6		96906	MS3456W18-10S
19	7		92578	A19BAE-1
19	8	2910-00-710-6054	96906	MS51321-1

By Order of the Secretary of the Army:

CARL E. VUONO
General, United States Army
Chief of Staff

Official:

WILLIAM J. MEEHAN, II
Brigadier General, United States Army
The Adjutant General

DISTRIBUTION:

To be distributed in accordance with DA Form 12-25E, Unit, Direct Support and General Support Maintenance requirements for Heater, Space (UH68G).

RECOMMENDED CHANGES TO EQUIPMENT TECHNICAL PUBLICATIONS

SOMETHING WRONG WITH THIS PUBLICATION?



THEN... JOT DOWN THE DOPE ABOUT IT ON THIS FORM. CAREFULLY TEAR IT OUT. FOLD IT AND DROP IT IN THE MAIL!

FROM: (PRINT YOUR UNIT'S COMPLETE ADDRESS)

PFC JOHN DOE
COA, 3d ENGINEER BN
FT. LEONARD WOOD, MO 63108

DATE SENT

PUBLICATION NUMBER

TM 5-4520-253-23P

PUBLICATION DATE

10 July 1990

PUBLICATION TITLE Heater, Space,
Multifuel with Blower

BE EXACT PIN-POINT WHERE IT IS

PAGE NO	PARA-GRAPH	FIGURE NO	TABLE NO
6	2-1 a		
B1		4-3	
125	line 20		

IN THIS SPACE TELL WHAT IS WRONG AND WHAT SHOULD BE DONE ABOUT IT:

In line 6 of paragraph 2-1a the manual states the engine has 6 cylinders. The engine on my set only has 4 cylinders. Change the manual to show 4 cylinders.

Callout 16 on figure 4-3 is pointing at a bolt. In key to figure 4-3, item 16 is called a shim - Please correct one or the other.

I ordered a gasket, item 19 on figure B-16 by NSN 2910-00-762-3001. I got a gasket but it doesn't fit. Supply says I got what I ordered, so the NSN is wrong. Please give me a good NSN

PRINTED NAME GRADE OR TITLE AND TELEPHONE NUMBER

JOHN DOE, PFC (268) 317-7111

SIGN HERE

JOHN DOE

DA FORM 1 JUL 79 2028-2

PREVIOUS EDITIONS ARE OBSOLETE.
DRSTS-M Overprint 1, 1 Nov 80

PS - IF YOUR OUTFIT WANTS TO KNOW ABOUT YOUR RECOMMENDATION MAKE A CARBON COPY OF THIS AND GIVE IT TO YOUR HEADQUARTERS

TEAR ALONG PERFORATED LINE

RECOMMENDED CHANGES TO EQUIPMENT TECHNICAL PUBLICATIONS



THEN... JOT DOWN THE DOPE ABOUT IT ON THIS FORM. CAREFULLY TEAR IT OUT. FOLD IT AND DROP IT IN THE MAIL!

SOMETHING WRONG WITH THIS PUBLICATION?

FROM (PRINT YOUR UNIT'S COMPLETE ADDRESS)

DATE SENT

PUBLICATION NUMBER

TM 5-4520-253-23P

PUBLICATION DATE

10 July 1990

PUBLICATION TITLE Heater, Space, Multifuel with Blower

BE EXACT PIN-POINT WHERE IT IS

PAGE NO

PARA-GRAPH

FIGURE NO

TABLE NO

IN THIS SPACE TELL WHAT IS WRONG AND WHAT SHOULD BE DONE ABOUT IT:

TEAR ALONG PERFORATED LINE

PRINTED NAME GRADE OR TITLE AND TELEPHONE NUMBER

SIGN HERE

DA FORM 1 JUL 79 2028-2

PREVIOUS EDITIONS ARE OBSOLETE.
DRSTS-M Overprint 2, 1 Nov 80.

PS --IF YOUR OUTFIT WANTS TO KNOW ABOUT YOUR RECOMMENDATION MAKE A CARBON COPY OF THIS AND GIVE IT TO YOUR HEADQUARTERS

The Metric System and Equivalents

Linear Measure

1 centimeter = 10 millimeters = .39 inch
 1 decimeter = 10 centimeters = 3.94 inches
 1 meter = 10 decimeters = 39.37 inches
 1 dekameter = 10 meters = 32.8 feet
 1 hectometer = 10 dekameters = 328.08 feet
 1 kilometer = 10 hectometers = 3,280.8 feet

Weights

1 centigram = 10 milligrams = .15 grain
 1 decigram = 10 centigrams = 1.54 grains
 1 gram = 10 decigrams = .035 ounce
 1 dekagram = 10 grams = .35 ounce
 1 hectogram = 10 dekagrams = 3.52 ounces
 1 kilogram = 10 hectograms = 2.2 pounds
 1 quintal = 100 kilograms = 220.46 pounds
 1 metric ton = 10 quintals = 1.1 short tons

Liquid Measure

1 centiliter = 10 milliliters = .34 fl. ounce
 1 deciliter = 10 centiliters = 3.38 fl. ounces
 1 liter = 10 deciliters = 33.81 fl. ounces
 1 dekaliter = 10 liters = 2.64 gallons
 1 hectoliter = 10 dekaliters = 26.42 gallons
 1 kiloliter = 10 hectoliters = 264.18 gallons

Square Measure

1 sq. centimeter = 100 sq. millimeters = .155 sq. inch
 1 sq. decimeter = 100 sq. centimeters = 15.5 sq. inches
 1 sq. meter (centare) = 100 sq. decimeters = 10.76 sq. feet
 1 sq. dekameter (are) = 100 sq. meters = 1,076.4 sq. feet
 1 sq. hectometer (hectare) = 100 sq. dekameters = 2.47 acres
 1 sq. kilometer = 100 sq. hectometers = .386 sq. mile

Cubic Measure

1 cu. centimeter = 1000 cu. millimeters = .06 cu. inch
 1 cu. decimeter = 1000 cu. centimeters = 61.02 cu. inches
 1 cu. meter = 1000 cu. decimeters = 35.31 cu. feet

Approximate Conversion Factors

To change	To	Multiply by	To change	To	Multiply by
inches	centimeters	2.540	ounce-inches	newton-meters	.007062
feet	meters	.305	centimeters	inches	.394
yards	meters	.914	meters	feet	3.280
miles	kilometers	1.609	meters	yards	1.094
square inches	square centimeters	6.451	kilometers	miles	.621
square feet	square meters	.093	square centimeters	square inches	.155
square yards	square meters	.836	square meters	square feet	10.764
square miles	square kilometers	2.590	square meters	square yards	1.196
acres	square hectometers	.405	square kilometers	square miles	.386
cubic feet	cubic meters	.028	square hectometers	acres	2.471
cubic yards	cubic meters	.765	cubic meters	cubic feet	35.315
fluid ounces	milliliters	29.573	cubic meters	cubic yards	1.308
pints	liters	.473	milliliters	fluid ounces	.034
quarts	liters	.946	liters	pints	2.113
gallons	liters	3.785	liters	quarts	1.057
ounces	grams	28.349	liters	gallons	.264
pounds	kilograms	.454	grams	ounces	.035
short tons	metric tons	.907	kilograms	pounds	2.205
pound-feet	newton-meters	1.356	metric tons	short tons	1.102
pound-inches	newton-meters	.11296			

Temperature (Exact)

°F	Fahrenheit temperature	5/9 (after subtracting 32)	Celsius temperature	°C
----	------------------------	----------------------------	---------------------	----

PIN: 061885-000