

TM 9-4520-272-14&P

TECHNICAL MANUAL

OPERATOR, FIELD AND SUSTAINMENT MAINTENANCE MANUAL INCLUDING REPAIR PARTS AND SPECIAL TOOLS LIST (RPSTL)

FOR

LARGE CAPACITY FIELD HEATER (LCFH), 350,000 BTU, INCLUDING DIESEL ENGINE

NSN 4520-01-500-1534 (EIC: VX8)



DISTRIBUTION STATEMENT A – Approved for public release; distribution is unlimited.

HEADQUARTERS, DEPARTMENT OF THE ARMY

1 JUNE 2006

WARNING SUMMARY

This warning summary contains general safety warnings and hazardous materials warnings that must be understood and applied during operation of this equipment. Failure to observe these precautions could result in serious injury or death to personnel. Also included are explanations of safety and hazardous materials icons used within this technical manual.

EXPLANATION OF SAFETY WARNING ICONS



CHEMICAL - drops of liquid on hand shows that the material will cause burns or irritation to human skin or tissue.

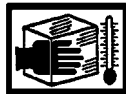

CRYOGENIC - hand in block of ice shows that the material is extremely cold and can injure human skin or tissue.



ELECTRICAL - electrical wire to arm with electricity symbol running through human body shows that shock hazard is present.



EXPLOSION - rapidly expanding symbol shows that the material may explode if subjected to high temperatures, sources of ignition or high pressure.



EYE PROTECTION - person with goggles shows that the material will injure the eyes.



FIRE - flame shows that a material may ignite and cause burns.



HEAVY OBJECT - human figure stooping over heavy object shows physical injury potential from improper lifting technique.



HEAVY PARTS - heavy object on human figure shows that heavy parts present a danger to life or limb.



HOT AREA - hand over object radiating heat shows that part is hot and can burn.



POISON - skull and crossbones shows that a material is poisonous or is a danger to life.



SHARP OBJECT - pointed object in hand shows that a sharp object presents a danger to limb.



VAPOR - human figure in a cloud shows that material vapors present a danger to life or health.

TM 9-4520-272-14&P



MOVING PARTS - hand with fingers caught between gears shows that the moving parts of the equipment present a danger to life or limb.



EAR PROTECTION - headphones over ears shows that noise level will harm ears.



ELECTRICAL - electrical wire to hand with electricity symbol running through hand shows that shock hazard is present.

GENERAL SAFETY WARNINGS DESCRIPTION



WARNING

The LCFH weighs approximately 625 pounds. Extreme care should be used at all times when moving it. Proper lifting equipment and observation of safety precautions is required to safely move and stack the LCFH. Under No Circumstances should anyone stand in the path of the LCFH when it is being lifted or moved. Serious injury or death may result.



WARNING

Some items associated with or installed in the LCFH require two to four people to lift/move. Use appropriate number of personnel when moving large, bulky, or heavy items. Never attempt to lift an item alone if it requires more than one person to avoid serious injury.



WARNING

The LCFH exhaust stack surface reaches a temperature of 150⁰ F (65.5⁰ C). Do not touch or allow bare skin to come in contact with the exhaust stack unless the LCFH has been shut down and cool. Coming in contact with hot surfaces may result in burns or other serious injury.

Do not allow bare skin to come in contact with the LCFH air outlet duct during operation. The LCFH air outlet duct reaches a temperature of 225⁰F (107⁰C) and may cause severe burns.



WARNING

Leather gloves and eye protection must be worn when performing maintenance. Failure to do so could result in serious injury to eyes or hands.



WARNING

Gloves, eye protection, and dust mask should be worn when handling chemicals such as cleaning solvents or other cleaning material. Failure to wear proper protection may result in skin irritation and/or eye injury.



WARNING

Hands and other body parts should be kept from the air inlet duct of the LCFH. Moving parts inside the duct could cause severe injury or death.

The engine access panel on the side of the LCFH should not be opened during operation. Moving parts inside the access door could cause serious injury or death.

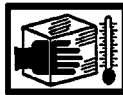

WARNING

Do not touch cold metal parts with bare hands. Frostbite can cause permanent injury to personnel.



WARNING



Fuels, lubricants, and solvents are toxic, flammable, and explosive. Wear protective goggles and gloves when refueling or lubricating in a well-ventilated area. Avoid any contact with skin, eyes, and change clothes whenever spilled upon. **ABSOLUTELY NO SMOKING** or eating in immediate area of heater operations. Do not perform fueling or lubricating actions in the vicinity of open flame or excessive heat. If dizziness is felt due to vapor inhalation, immediately seek fresh air and medical attention. If contact with eyes or skin is made, flush with clean water and seek medical help immediately.

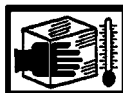

WARNING

Personnel should wear gloves when fueling the LCFH or performing any task in which fuel may come in contact with bare skin. Fuel coming into contact with bare skin under arctic conditions may cause frostbite or other serious injury.



WARNING

Jewelry can conduct electricity and become entangled in the LCFH. Failure to remove jewelry on the LCFH can cause injury or death.



WARNING

Hearing protection should be worn when performing any troubleshooting or maintenance function requiring that the heater be operating with any of the access panels open or closed within close vicinity. Failure to wear ear protection could result in hearing loss or damage.



WARNING

Disconnect the negative battery terminal on the battery closest the engine bay access door before performing maintenance involving the batteries. Failure to do so may result in shock or other serious injury.



WARNING

Do not place the LCFH over any fuel and/or electrical lines. Placing the heater over fuel and/or electrical lines may result in fire or explosion causing serious injury or death.



WARNING

The LCFH should not be positioned any closer than 2 feet from an external bulk fuel supply. Placing the heater closer than 2 feet from a bulk fuel supply may result in fire or explosion causing serious injury or death.



WARNING

To prevent possible deadly carbon monoxide (CO) concentration, operate the LCFH only in well-ventilated areas and place the unit as far away as possible from enclosure vent, door, and window openings. Failure to do so may result in serious injury or death.

TM 9-4520-272-14&P



WARNING

Do not operate radio equipment within 4 feet of the LCFH due to possible Electro-Magnetic Interference (EMI). If the heater interferes with other electronics equipment in its vicinity, move the equipment away from the heater until the interference is no longer a problem. Failure to comply with this warning may result in equipment endangerment, radio interference, and/or severe injury to personnel.

CHANGE
NO. 1

HEADQUARTERS
DEPARTMENT OF THE ARMY
WASHINGTON, DC, 21 September 2007

TECHNICAL MANUAL

OPERATOR, FIELD AND SUSTAINMENT
MAINTENANCE MANUAL
INCLUDING REPAIR PARTS AND SPECIAL TOOLS LIST (RPSTL)
FOR
LARGE CAPACITY FIELD HEATER (LCFH),
350,000 BTU, INCLUDING DIESEL ENGINE
NSN 4520-01-500-1534 (EIC: VX8)

DISTRIBUTION STATEMENT A: - Approved for public release; distribution is unlimited. TM 9-4520-272-14&P, 1 June 2006, is updated as follows:

1. File this sheet in front of the manual for reference.
2. This change incorporates updated maintenance and supply information.
3. New or updated text is indicated by a vertical bar in the outer margin of the page.
4. Remove old pages and insert new pages as indicated below:

<u>Remove Pages</u>	<u>Insert Pages</u>	<u>Remove Pages</u>	<u>Insert Pages</u>
Title	Title	Sample 2028	Sample 2028
A – B	A - B	DA form 2028	DA form 2028
i – v/(vi Blank)	i – v/(vi Blank)	DA form 2028	DA form 2028
Index 1 - Index 6	Index 1 - Index 6	DA form 2028	
Electronic Instructions	Electronic Instructions		

5. Replace the following work packages with their new revised version:

<u>Work Package Number</u>	<u>Work Package Number</u>	<u>Work Package Number</u>	<u>Work Package Number</u>
WP 0001 00	WP 0043 00	WP 0084 00	WP 0102 00
WP 0002 00	WP 0046 00	WP 0085 00	WP 0103 00
WP 0006 00	WP 0055 00	WP 0086 00	WP 0104 00
WP 0007 00	WP 0069 00	WP 0088 00	WP 0105 00
WP 0008 00	WP 0073 00	WP 0092 00	WP 0107 00
WP 0010 00	WP 0074 00	WP 0094 00	WP 0110 00
WP 0015 00	WP 0077 00	WP 0095 00	WP 0111 00
WP 0016 00	WP 0078 00	WP 0097 00	WP 0112 00
WP 0018 00	WP 0079 00	WP 0098 00	WP 0114 00
WP 0033 00	WP 0081 00	WP 0099 00	WP 0117 00
WP 0040 00	WP 0083 00	WP 0101 00	WP 0119 00

6. Add the following new work package.

Work Package Number
WP 0006 01

TM 9-4520-272-14&P

C-1

By Order of the Secretary of the Army:

GEORGE W. CASEY, JR.
General, United States Army
Chief of Staff

Official:

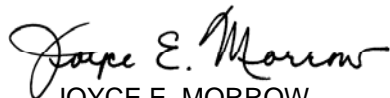
JOYCE E. MORROW
Administrative Assistant to the
Secretary of the Army
0725601

Distribution: To be distributed in accordance with initial distribution number (IDN) 256904 requirements for TM 9-4520-272-14&P.

TM 9-4520-272-14&P

INSERT LATEST CHANGED PAGES/WORK PACKAGES. DESTROY SUPERSEDED DATA.

LIST OF EFFECTIVE PAGES/WORK PACKAGES

NOTE: The portion of text affected by the change is indicated by a vertical bar in the outer margins of the page. Changes to illustrations are indicated by a vertical bar adjacent to the title. Zero in the "Change No." column indicates an original page or work package.

Dates of issue for the original manual and changed pages/work packages are:

Original 0 1 June 2006
 Change 1 21 September 2007

**TOTAL NUMBER OF PAGES FOR FRONT AND REAR MATTER IS 46 AND TOTAL
 NUMBER OF WORK PACKAGES IS 120, CONSISTING OF THE FOLLOWING:**

Page/WP No.	Change No.	Page/WP No.	Change No.
Title	1	WP 0032 00 (2 pgs)	0
a – e/(f Blank) (6 pgs)	0	WP 0033 00 (8 pgs)	1
i – v/(vi Blank) (6 pgs)	1	WP 0034 00 (4 pgs)	0
WP 0001 00 (4 pgs)	1	WP 0035 00 (4 pgs)	0
Chp 1 title page	0	WP 0036 00 (2 pgs)	0
WP 0002 00 (16 pgs)	1	WP 0037 00 (2 pgs)	0
WP 0003 00 (2 pgs)	0	WP 0038 00 (4 pgs)	0
Chp 2 title page	0	WP 0039 00 (8 pgs)	0
WP 0004 00 (4 pgs)	0	WP 0040 00 (6 pgs)	1
WP 0005 00 (38 pgs)	0	WP 0041 00 (4 pgs)	0
WP 0006 00 (4 pgs)	1	WP 0042 00 (4 pgs)	0
WP 0006 01 (2 pgs)	1	WP 0043 00 (4 pgs)	1
Chp 3 title page	0	WP 0044 00 (6 pgs)	0
WP 0007 00 (4 pgs)	1	WP 0045 00 (2 pgs)	0
WP 0008 00 (8 pgs)	1	WP 0046 00 (4 pgs)	1
Chp 4 title page	0	WP 0047 00 (2 pgs)	0
WP 0009 00 (2 pgs)	0	WP 0048 00 (2 pgs)	0
WP 0010 00 (14 pgs)	1	WP 0049 00 (2 pgs)	0
WP 0011 00 (2 pgs)	0	WP 0050 00 (12 pgs)	0
WP 0012 00 (2 pgs)	0	WP 0051 00 (4 pgs)	0
WP 0013 00 (2 pgs)	0	WP 0052 00 (2 pgs)	0
WP 0014 00 (2 pgs)	0	WP 0053 00 (2 pgs)	0
Chp 5 title page	0	WP 0054 00 (8 pgs)	0
WP 0015 00 (4 pgs)	1	WP 0055 00 (4 pgs)	1
WP 0016 00 (20 pgs)	1	WP 0056 00 (2 pgs)	0
Chp 6 title page	0	WP 0057 00 (2 pgs)	0
WP 0017 00 (2 pgs)	0	WP 0058 00 (4 pgs)	0
WP 0018 00 (6 pgs)	1	WP 0059 00 (2 pgs)	0
WP 0019 00 (2 pgs)	0	WP 0060 00 (4 pgs)	0
WP 0020 00 (2 pgs)	0	WP 0061 00 (4 pgs)	0
WP 0021 00 (2 pgs)	0	WP 0062 00 (2 pgs)	0
WP 0022 00 (2 pgs)	0	WP 0063 00 (4 pgs)	0
WP 0023 00 (2 pgs)	0	WP 0064 00 (2 pgs)	0
WP 0024 00 (2 pgs)	0	WP 0065 00 (4 pgs)	0
WP 0025 00 (4 pgs)	0	WP 0066 00 (2 pgs)	0
WP 0026 00 (4 pgs)	0	WP 0067 00 (2 pgs)	0
WP 0027 00 (4 pgs)	0	WP 0068 00 (2 pgs)	0
WP 0028 00 (6 pgs)	0	WP 0069 00 (4 pgs)	1
WP 0029 00 (4 pgs)	0	Chp 7 title page	0
WP 0030 00 (4 pgs)	0	WP 0070 00 (2 pgs)	0
WP 0031 00 (4 pgs)	0	WP 0071 00 (2 pgs)	0

A

Change 1

TM 9-4520-272-14&P

Page/WP No.	Change No.	Page/WP No.	Change No.
Chp 8 title page	0	WP 0096 00 (8 pgs)	0
WP 0072 00 (2 pgs)	0	WP 0097 00 (10 pgs)	1
WP 0073 00 (4 pgs)	1	WP 0098 00 (4 pgs)	1
WP 0074 00 (6 pgs)	1	WP 0099 00 (6 pgs)	1
WP 0075 00 (4 pgs)	0	WP 0100 00 (6 pgs)	0
WP 0076 00 (6 pgs)	0	WP 0101 00 (8 pgs)	1
WP 0077 00 (4 pgs)	1	WP 0102 00 (16 pgs)	1
WP 0078 00 (18 pgs)	1	WP 0103 00 (4 pgs)	1
WP 0079 00 (8 pgs)	1	WP 0104 00 (4 pgs)	1
Chp 9 title page	0	WP 0105 00 (4 pgs)	1
WP 0080 00 (2 pgs)	0	WP 0106 00 (4 pgs)	0
WP 0081 00 (4 pgs)	1	WP 0107 00 (4 pgs)	1
Chp 10 title page	0	WP 0108 00 (4 pgs)	0
WP 0082 00 (2 pgs)	0	WP 0109 00 (4 pgs)	0
WP 0083 00 (4 pgs)	1	WP 0110 00 (4 pgs)	1
WP 0084 00 (6 pgs)	1	WP 0111 00 (4 pgs)	1
WP 0085 00 (6 pgs)	1	WP 0112 00 (4 pgs)	1
WP 0086 00 (4 pgs)	1	WP 0113 00 (2 pgs)	0
WP 0087 00 (2 pgs)	0	WP 0114 00 (2 pgs)	1
WP 0088 00 (8 pgs)	1	WP 0115 00 (4 pgs)	0
WP 0089 00 (2 pgs)	0	WP 0116 00 (6 pgs)	0
Chp 11 title page	0	WP 0117 00 (4 pgs)	1
WP 0090 00 (2 pgs)	0	WP 0118 00 (2 pgs)	0
WP 0091 00 (4 pgs)	0	WP 0119 00 (2 pgs)	1
WP 0092 00 (8 pgs)	1	Index 1 – Index 6 (6 pgs)	1
WP 0093 00 (6 pgs)	0	FO 1 – FO 4 (8 pgs)	0
WP 0094 00 (6 pgs)	1		
WP 0095 00 (8 pgs)	1		

HEADQUARTERS
DEPARTMENT OF THE ARMY
WASHINGTON, D.C., 1 JUNE 2006

TECHNICAL MANUAL
OPERATOR, FIELD AND SUSTAINMENT
MAINTENANCE MANUAL
INCLUDING REPAIR PARTS AND SPECIAL TOOLS LIST (RPSTL)
FOR
LARGE CAPACITY FIELD HEATER (LCFH),
350,000 BTU, INCLUDING DIESEL ENGINE
NSN 4520-01-500-1534 (EIC: VX8)

You can help improve this manual. If you find any mistakes, or if you know of a way to improve the procedures, please let us know. Mail your letter, DA Form 2028 (Recommended Changes to Publications and Blank Forms) or DA Form 2028 located in back of this manual directly to: Commander, U.S. Army TACOM Life Cycle Management Command, ATTN: AMSTA-LC-SECT, 15 Kansas St., Natick, MA 01760. You may also submit your recommended changes via electronic mail or by fax. Our fax number is: DSN 256-5205, COMM: 508-233-5205. Our email address is soldier.pubs@us.army.mil. A reply will be furnished to you.

DISTRIBUTION STATEMENT A – Approved for public release. Distribution is unlimited.

TABLE OF CONTENTS

WP Sequence No.

WARNING SUMMARY

HOW TO USE THIS MANUAL

CHAPTER 1. EQUIPMENT INFORMATION, EQUIPMENT DESCRIPTION AND THEORY OF OPERATION

General Information	0001 00
Equipment Description and Data	0002 00
Theory of Operation	0003 00

CHAPTER 2. OPERATOR INSTRUCTIONS

Description and Use Of Operator Controls and Indicators	0004 00
Operation Under Usual Conditions	0005 00
Operation Under Unusual Conditions	0006 00
Emergency Engine Shutdown Procedures	0006 01

TABLE OF CONTENTS - continued

WP Sequence No.

CHAPTER 3. OPERATOR TROUBLESHOOTING INSTRUCTIONS

Operator Malfunction Symptom Index 0007 00

Operator Troubleshooting Procedures..... 0008 00

CHAPTER 4. OPERATOR MAINTENANCE INSTRUCTIONS

Operator PMCS Introduction Work Package 0009 00

Operator PMCS Table..... 0010 00

Operator Maintenance Procedure Introduction..... 0011 00

Operator Maintenance Air Cleaner 0012 00

Operator Maintenance CO Detector-Operator Control Box..... 0013 00

Operator Maintenance Wheel Retraction Assembly..... 0014 00

CHAPTER 5. UNIT MAINTENANCE TROUBLESHOOTING INSTRUCTIONS

Unit Malfunction Symptom Index 0015 00

Unit Troubleshooting Procedures 0016 00

CHAPTER 6. UNIT MAINTENANCE INSTRUCTIONS

Unit PMCS Introduction Work Package 0017 00

Unit Preventive Maintenance Checks and Services (PMCS) Table 0018 00

Unit Maintenance Procedures Introduction..... 0019 00

Unit Maintenance Cabinet Assembly 0020 00

Unit Maintenance Sound Sheet Installation 0021 00

Unit Maintenance Jack Assembly 0022 00

Unit Maintenance Door Latch 0023 00

Unit Maintenance Operator Box Mounting Bracket 0024 00

Unit Maintenance Carbon Monoxide Detector - Cabinet 0025 00

Unit Maintenance Engine Throttle Shutdown Solenoid 0026 00

Unit Maintenance Fuel Filter 0027 00

Unit Maintenance Electrical Fuel Pump 0028 00

Unit Maintenance Electrical Fuel Pump 3-Way Fuel Solenoid Valve 0029 00

Unit Maintenance Main Battery Power Switch..... 0030 00

Unit Maintenance Burner Fuel Valve Assembly 3-Way Solenoid Valve..... 0031 00

Unit Maintenance Burner Fuel Valve Assembly 2-Way Solenoid Valve..... 0032 00

Unit Maintenance Burner Fuel Pump Assembly 0033 00

Unit Maintenance Fuel Tank 0034 00

Unit Maintenance Fuel Tank Level Switch..... 0035 00

Unit Maintenance External Fuel Supply Port 0036 00

Unit Maintenance Safety Screen 0037 00

Unit Maintenance Inlet Fan Assembly 0038 00

Unit Maintenance 24V Alternator Assembly and Drive Belt..... 0039 00

Unit Maintenance Coupling Assembly 0040 00

Unit Maintenance Diesel Engine Rocker Arm Assembly 0041 00

Unit Maintenance Diesel Engine Air Cleaner..... 0042 00

Unit Maintenance Diesel Engine Fuel Injector..... 0043 00

Unit Maintenance Diesel Engine Electric Starter 0044 00

Unit Maintenance Diesel Engine Flywheel Housing and Cover..... 0045 00

Unit Maintenance Diesel Engine Oil Change..... 0046 00

TABLE OF CONTENTS – continued

WP Sequence No.

CHAPTER 6. UNIT MAINTENANCE INSTRUCTIONS (continued)	
Unit Maintenance Diesel Engine Oil Fill Cap	0047 00
Unit Maintenance Diesel Engine Oil Filter Cleaning	0048 00
Unit Maintenance Combustion Blower	0049 00
Unit Maintenance Burner Electrode and Nozzle Assembly	0050 00
Unit Maintenance Burner Cone	0051 00
Unit Maintenance Ignition Assembly	0052 00
Unit Maintenance Flame Sensor	0053 00
Unit Maintenance Heat Exchanger	0054 00
Unit Maintenance Outlet Temperature Sensor	0055 00
Unit Maintenance Wire Harness Assemblies	0056 00
Unit Maintenance Battery Terminal Connector	0057 00
Unit Maintenance Battery	0058 00
Unit Maintenance Battery T-Bar	0059 00
Unit Maintenance Slave Receptacle	0060 00
Unit Maintenance Operator Control Box Cable Assembly	0061 00
Unit Maintenance Relay Box Assembly	0062 00
Unit Maintenance Main Printed Circuit Board	0063 00
Unit Maintenance Mechanical Hour Meter	0064 00
Unit Maintenance Carbon Monoxide Detector – Operator Control Box	0065 00
Unit Maintenance Insulated Air Duct 16-in X 15-ft	0066 00
Unit Maintenance Heat Exchanger Exhaust Tube	0067 00
Unit Maintenance External Fuel Hose Assembly	0068 00
Unit Maintenance Preparation for Shipment and Storage	0069 00

CHAPTER 7. DIRECT SUPPORT TROUBLESHOOTING INSTRUCTIONS	
Direct Support Malfunction Symptom Index	0070 00
Direct Support Troubleshooting Procedures	0071 00

CHAPTER 8. DIRECT SUPPORT MAINTENANCE INSTRUCTIONS	
Direct Support Maintenance Procedures Introduction	0072 00
Direct Support Cylinder Block	0073 00
Direct Support Fuel Injection Pump	0074 00
Direct Support Governor Control	0075 00
Direct Support Oil Pump	0076 00
Direct Support Rocker Arm Assembly	0077 00
Direct Support Diesel Engine	0078 00
Direct Support Cylinder Head	0079 00

CHAPTER 9. GENERAL SUPPORT TROUBLESHOOTING INSTRUCTIONS	
General Support Malfunction Symptom Index	0080 00
General Support Troubleshooting Procedures	0081 00

CHAPTER 10. GENERAL SUPPORT MAINTENANCE INSTRUCTIONS	
General Support Maintenance Procedures Introduction	0082 00
General Support Balancer Shaft	0083 00
General Support Camshaft	0084 00
General Support Crankshaft	0085 00

TABLE OF CONTENTS - continued

WP Sequence No.

CHAPTER 10. GENERAL SUPPORT MAINTENANCE INSTRUCTIONS (continued)

General Support Fuel Injection Pump.....	0086 00
General Support Governor.....	0087 00
General Support Piston and Connecting Rod.....	0088 00
Main Wiring Harness Assembly.....	0089 00

CHAPTER 11. SUPPORTING INFORMATION

References	0090 00
MAC Introduction Work Package.....	0091 00
Maintenance Allocation Chart.....	0092 00
Repair Parts and Special Tools List (RPSTL) Introduction.....	0093 00
RPSTL Large Capacity Field Heater.....	0094 00
RPSTL Cabinet Assembly	0095 00
RPSTL Cabinet Assembly, Sheet Sound Installation	0096 00
RPSTL Fuel Panel Assembly.....	0097 00
RPSTL Burner Fuel Valve Assembly.....	0098 00
RPSTL Fuel Tank.....	0099 00
RPSTL Inlet Fan Assembly.....	0100 00
RPSTL Assembly, Engine System.....	0101 00
RPSTL Diesel Engine	0102 00
RPSTL Ignition Assembly	0103 00
RPSTL Burner Nozzle Assembly	0104 00
RPSTL Burner Assembly	0105 00
RPSTL Heat System Assembly	0106 00
RPSTL Heat Exchanger Transition Tube Assembly.....	0107 00
RPSTL Battery Assembly	0108 00
RPSTL NATO Slave Connector.....	0109 00
RPSTL Main Control Board Assembly.....	0110 00
RPSTL Operator Control Box Assembly.....	0111 00
RPSTL Air Ducts	0112 00
RPSTL Duct Covers.....	0113 00
RPSTL Bulk Items.....	0114 00
NSN Index	0115 00
Part Number Index.....	0116 00
COEI and BII	0117 00
Additional Authorization List (AAL)	0118 00
Expendable and Durable Items List.....	0119 00
 ALPHABETICAL INDEX	 INDEX-1
 LCFH Wiring Diagram.....	 FP-1
LCFH Wiring Schematic.....	FP-3
LCFH Fuel System Schematic.....	FP-5
LCFH Electrode Alignment Tool	FP-7

HOW TO USE THIS MANUAL

This Manual contains General Information, Operating Instructions, Preventive Maintenance Checks and Services (PMCS), Troubleshooting, and Maintenance Information for the Large Capacity Field Heater.

The manual is comprised of 11 chapters as follows:

Chapter number	Description
1	General Information
2	Operator Instructions
3	Operator Troubleshooting Instructions
4	Operator Maintenance Instructions
5	Unit Troubleshooting Instructions
6	Unit Maintenance Instructions
7	Direct Support Troubleshooting Instructions
8	Direct Support Maintenance Instructions
9	General Support Troubleshooting Instructions
10	General Support Maintenance Instructions
11	Supporting Information

Manual Organization and Page Numbering System. The Manual is divided into eleven major chapters that detail the topics mentioned above. Within each chapter are work packages covering a wide range of topics. Each work package is numbered sequentially starting at page 1. The work package has its own page numbering scheme and is independent of the page numbering used by other work packages. Every work package has an even number of pages so that it does not interfere with any other work package. Each page of a work package has a page number of the form XXXX YY-ZZ where “XXXX” is the work package number (e.g. 0010 is work package 10). “YY” is a number that allows for a work package to be inserted between two existing work packages without disturbing the remainder of the TM (e.g WP 0010 01 would fall between WP 0010 and WP 0011). “ZZ” represents the number of the page within that work package. A page number such as 0010 00-1/(2 Blank) means that page 1 contains information but page 2 of that work package has been intentionally left blank. A page number such as 0010 00-(1 Blank)/2 means that page 1 of that work package has been intentionally left blank but page 2 contains information.

Illustrations. Illustrations for procedures in this manual always follow the procedure. For example, if given a procedural instruction such as “1. Locate the pump assembly (1).”, the (1) references the photo or illustration immediately *following* the procedure.

Finding Information. The Table of Contents permits the reader to find information in the manual quickly. The reader should start here first when looking for a specific topic. The Table of Contents lists the topics contained within each chapter and the work package sequence number where it can be found.

Example: If the reader were looking for instructions on maintaining the “Air Cleaner”, which in this manual is an Operator Maintenance topic, the Table of Contents indicates that Operator Maintenance information can be found in Chapter 4. Scanning down the listings for Chapter 4, “Operator Maintenance Instructions” information for “Air Cleaner” maintenance can be found in WP 0012 00 (i.e. Work Package 12).

An Alphabetical Index can be found at the back of the manual. It lists specific topics with the corresponding work package.

**OPERATOR, FIELD, AND SUSTAINMENT MAINTENANCE
LARGE CAPACITY FIELD HEATER (LCFH)
GENERAL INFORMATION**

SCOPE

This manual contains an equipment description, operating instructions and maintenance procedures for the Large Capacity Field Heater (LCFH). It also includes references to publications that contain information on separately documented components of the LCFH.

MAINTENANCE FORMS AND PROCEDURES

Department of the Army forms and procedures used for LCFH maintenance shall be those prescribed by DA PAM 738-750, The Army Maintenance Management System (TAMMS) (Maintenance Management Update).

REPORTING EQUIPMENT IMPROVEMENT RECOMMENDATIONS (EIR)

If your LCFH needs improvement, let us know. Send us an EIR. You, the user, are the only one who can tell us what you don't like about your equipment. Let us know why you don't like the design or performance. If you have Internet access, the easiest and fastest way to report problems or suggestions is to go to <https://aeps.ria.army.mil/aepspublic.cfm> (scroll down and choose the "Submit Quality Deficiency Report" bar). The Internet form lets you choose to submit an Equipment Improvement Recommendation (EIR), a Product Quality Deficiency Report (PQDR or a Warranty Claim Action). You may also submit your information using an SF 368 (Product Quality Deficiency Report). You can send your SF 368 via e-mail, regular mail, or facsimile using the addresses/facsimile numbers specified in DA Pam 750-8, The Army Maintenance Management System (TAMMS) Users Manual. We will send you a reply.

CORROSION PREVENTION AND CONTROL

Corrosion Prevention and Control (CPC) of Army materiel is a continuing concern. It is important that any corrosion problems with this item be reported so that the problem can be corrected and improvements can be made to prevent the problem in future items. While corrosion is typically associated with rusting of metals, it can also include deterioration of other materials, such as rubber and plastic. Unusual cracking, softening, swelling, or breaking of these materials may be a corrosion problem.

If a corrosion problem is identified, it can be reported using SF 368, Product Quality Deficiency Report. Use of key words such as "corrosion," "rust," "deterioration," or "cracking" will ensure that the information is identified as a CPC problem.

The form should be submitted to the address specified in DA PAM 738-750, Functional Users Manual for the Army Maintenance Management System (TAMMS).

DESTRUCTION OR ARMY MATERIEL TO PREVENT ENEMY USE

Refer to TM 750-244-3, Procedures for Destruction of Equipment to Prevent Enemy Use, for information about destruction.

PREPARATION FOR STORAGE AND SHIPMENT

Before placing the LCFH in administrative storage or preparing the system for shipment, current maintenance services must be applied; defects and failures corrected; and Modification Work Orders (MWO's) applied. Prepare the system for movement, storage, or shipment as described in Chapter 2.

Placement of equipment in storage. Equipment should be placed in storage for limited periods only, when a shortage of maintenance capability exists. Items should be mission ready within 24 hours, or within time factors set by directing authority. During storage periods, maintenance records must be kept current.

Storage site selection. Covered space is preferred. When sufficient covered space is not available, priority should be given to items that are most susceptible to deterioration from the elements. Open sites should be improved hardstand, if available. Unimproved sites should be firm, well-drained locations, free of excessive vegetation.

WARRANTY INFORMATION

The LCFH components are warranted by the manufacturer for 5 years. The warranty starts on the date found in block 23, DA Form 2408-9, Equipment Control Record, in the log book. The warranty date is also displayed on the warranty information data plate mounted on the side of the heater. Report defects in material or workmanship to your supervisor, who will take appropriate action through your unit maintenance shop.

OFFICIAL NOMENCLATURE AND CROSS REFERENCE

The table below lists the common names of components and their official nomenclature as used throughout this manual.

COMMON NAME	OFFICIAL NOMENCLATURE
Heater	Large Capacity Field Heater

LIST OF ABBREVIATIONS/ACRONYMS.			
AAL	Additional Authorization List	LCFH	Large Capacity Field Heater
BII	Basic Issue Item	l	Liter(s)
°C	Celsius	lb	Pound(s)
CARC	Chemical Agent Resistant Coating	m	Meter(s)
COEI	Component of End Item	MOPP-IV	Mission Oriented Protective Posture - IV
CPC	Corrosion Prevention Control	MOS	Military Occupational Specialty
CTA	Common Table of Allowances	MTOE	Modified Table of Organization and Equipment
EIR	Equipment Improvement Recommendation	NBC	Nuclear, Biological, and Chemical
EMI	Electromagnetic Interference	PMCS	Preventive Maintenance Checks and Services
°F	Fahrenheit	POL	Petroleum, Oil, and Lubricant
ft	Foot	ppm	Parts per million
ft-lb	Foot/pound(s)	RPM	Revolutions per minute
Hz	Hertz	RPSTL	Repair Parts and Special Tools List
in	Inch(es)	TOE	Table of Organization and Equipment
kg	Kilogram(s)	U/M	Unit of Measure
kPa	Kilopascal(s)	UOC	Usable On Code
		V	Volts

SUPPORTING INFORMATION FOR REPAIR PARTS, SPECIAL TOOLS, AND SUPPORT EQUIPMENT

Refer to the Maintenance Allocation Chart (MAC) in Work Package 0092 00 for a listing of maintenance items and tools or test equipment. Refer to the Repair Parts and Special Tools List (RPSTL) beginning in work package 0093 00 for details concerning repair parts.

WARNINGS, CAUTIONS, AND NOTES

Be alert and note **WARNINGS, CAUTIONS, and NOTES**. These provide for safe operation of the equipment, and protect you and your equipment from injury and damage.

EQUIPMENT CAPABILITIES AND FEATURES

Characteristics of the LCFH are as follows:

- The LCFH has 16 inch inlet and outlet duct fittings.
- The heater has an internal 35-gallon fuel tank adequate for 8 hours operation at maximum heat output, with an external fuel supply connection and fuel hose provided.
- The LCFH runs on diesel or jet fuels, including JP-8, DF-A, DF-1 or DF-2. The heater size is 40 inches H x 44 inches W x 62 inches L and weighs 622 pounds in the ready-to-operate configuration.
- The heater starts using its two internal Optima batteries with ambient temperatures as low as -40°F. A NATO slave connector is provided to assist the heater in starting at temperatures as low as -65°F.
- The LCFH is self-powered by a 6.5 Hp militarized diesel engine. ■
- Engine noise control is accomplished with vibration isolation mounts, sound-deadening materials, and an oversized exhaust muffler system. A large, low rpm impeller wheel minimizes ventilation blower noise.
- The heater is controlled via an integral control panel connected to the heater with a 25-foot cable that is brought into the shelter during operation.
- Automatic safety controls give protection from over temperature or flame out faults.
- The controls can be operated when wearing arctic mittens or MOPP-IV gear and are shielded from the effects of Electromagnetic Interference (EMI) and are readily understandable.
- Both primary and backup carbon monoxide (CO) detectors in the ventilation air stream audibly announce high CO levels and are interlocked with the burner control logic.
- The LCFH aluminum housing and welded aluminum frame form a rugged, yet lightweight, structure suitable for military transport and airdrop.
- The heater has tie-down sling provisions, and forklift guides enhancing its general transportability; handles and deployable wheels allow for local mobility.

- The LCFH resists damage from rain, salt fog, fungus, and will withstand a storage and transportation temperature range from –65°F to 160°F.
- Heater and all accessory items can be decontaminated after a chemical or biological attack.
- Engine, burner components, and heat exchanger have been selected for low maintenance and long life, and the modular design provides short Mean Time to Repair (MTTR).

END OF WORK PACKAGE

CHAPTER 1

**DESCRIPTION
AND
THEORY OF OPERATION**

LARGE CAPACITY FIELD HEATER (LCFH)

**OPERATOR, FIELD AND SUSTAINMENT MAINTENANCE
LARGE CAPACITY FIELD HEATER (LCFH)
EQUIPMENT DESCRIPTION AND DATA**

LOCATION AND DESCRIPTION OF MAJOR COMPONENTS

The following are the major components of the Large Capacity Field Heater (LCFH). A brief description of the function of each component and its location is detailed below.

JACK ASSEMBLY. Located on the front of the heater, the jack assembly permits the front wheel to be lowered in preparation for movement or raised in order for the heater to rest on the snow skids in preparation for use.



10 IN. NON-PNEUMATIC RETRACTABLE WHEELS. The non-pneumatic wheels located on either side of the LCFH assist in the movement and placement of the heater.



WHEEL CHOCKS. Located in a stowage area just above the retractable wheels, the wheel chocks prevent the heater from rolling when the wheels are in the down and deployed position.



SNOW SKIDS. Located on the underside of the LCFH, the snow skids provide a way for the LCFH to be moved in snowy conditions and a support for the heater when the wheels are retracted.

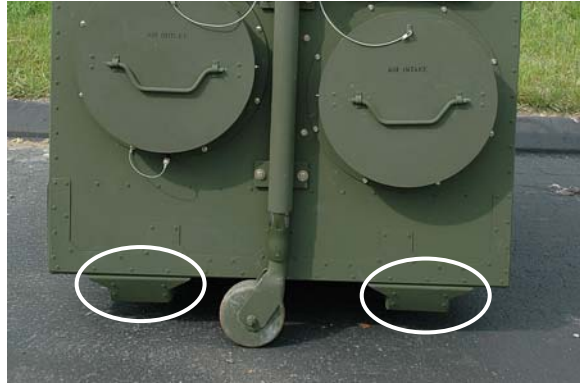

FORK LIFT POCKETS. Standard 10-inch by 3-inch forklift pockets are provided on either side of the heater to permit lifting the LCFH from its transport and placing it into position outside the shelter.



LOCAL MOBILITY HANDLES. Hand rails are installed at either end of the heater to assist in fine positioning the LCFH outside the shelter.



LIFT/TIE DOWN RINGS. Provided at the top four corners of the LCFH to permit airlifting of the heater or to provide tie down points when the heater is transported.



SLAVE CONNECTOR. A slave connector is mounted on the rear sidewall of the heater on the fresh air inlet side. The slave connector is designed to be connected to a 24V source to provide an additional source of power in conditions of extreme cold.

The slave connector is not to be used to provide power to other vehicles or equipment.



DUCT COVERS. Duct covers are provided to cover the inlet and outlet air ducts when the LCFH is being moved or is in storage.



AIR INLET. Permits fresh air to enter the LCFH for heating.



HEATED AIR OUTLET. Conducts heated air from the LCFH into the shelter.



FRESH AIR DAMPER. Located above the air inlet, the fresh air damper permits the operator to add fresh make up air to the air that is recirculated throughout the shelter. A spring loaded prop is located under the fresh air damper to allow the operator to vary the size of the opening.



INLET AND OUTLET DUCTS. The two flexible inlet and outlet ducts connect between the fresh air inlet and heated air outlet of the LCFH and the shelter duct openings. Ducts are shown compressed in their stowed condition.



FUEL FILLER PORT. The fuel filler port is located to the right of the fuel access door and permits fuel to be added to the internal fuel tank.



FUEL GAUGE. The fuel gauge is located next to the fuel filler port and provides an indication of the amount of fuel in the LCFH internal tank.

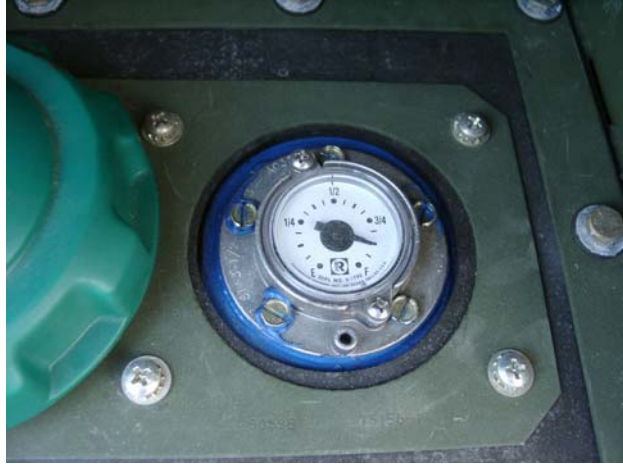

FUEL TANK. The fuel tank is located at the rear bottom end of the heater and is accessed through a quick disconnect fitting at the rear of the heater. The fuel tank is constructed of a crosslinked polyethylene and has a capacity of 35 gallons.



EXTERNAL FUEL CONNECTION. The external fuel connection is located above the fuel filler port and fuel gauge and permits the LCFH to be operated from an external bulk fuel supply, greatly extending its operating time.

CAUTION

The external fuel connection should not be used if the internal fuel tank is ruptured or otherwise leaking as the fuel system utilizes a continuous fuel loop-back design.



FUEL HOSE. This 25-foot flexible fuel hose is specially designed for the arctic environment and permits the LCFH to be used with an external fuel supply. It also provides a means to refuel the internal tank. The fuel hose is stowed internally on the inside of the engine access door when not in use.



EXHAUST STACK STOWAGE AREA. Allows the removable exhaust stack to be stowed prior to movement or storage.



EXHAUST STACK. A removable exhaust stack is located on the top of the LCFH and conducts combustion gases from the diesel engine and the burner to the outside air. The stack is removed when the heater is transported and stowed in the exhaust stack stowage compartment located at the lower front portion of the heater.



ENGINE ACCESS DOOR. Located on the air inlet side of the heater, the engine access door permits entry to the side of the LCFH for the maintenance of selected items including the diesel engine, alternator, and batteries.



OPERATOR CONTROL PANEL STORAGE AREA. The control panel and attached 25-foot cable is stowed in this area when the heater is being moved or prepared for storage.



OPERATOR CONTROL PANEL. Located on the top surface of the LCFH, the operator control panel is connected to the heater with a 25-foot cable. The control panel provides all control functions such as power ON/OFF, fuel onboard/external selector, fault reset, vent manual/auto, temperature control, and temperature sensor. The control panel also features an LED display that provides status information to the operator as well as fault information should a problem occur.



FUEL SYSTEM ACCESS DOOR. The fuel system access door permits access to the fuel filter and priming fuel pump. It also provides a stowage location for the technical manual and the electrode adjustment tool.



BURNER DOOR WITH SIGHT GLASS OPENING. The burner door with sight glass opening permits access to the burner area for maintenance. The sight glass offers the operator a visual confirmation of the burner flame.



HEAT EXCHANGER COVER. Removable top cover over the heat exchanger permits access to the assembly for maintenance or servicing.



ENGINE BAY COVER. Removable top cover over the engine bay that permits access to the engine for maintenance or servicing.

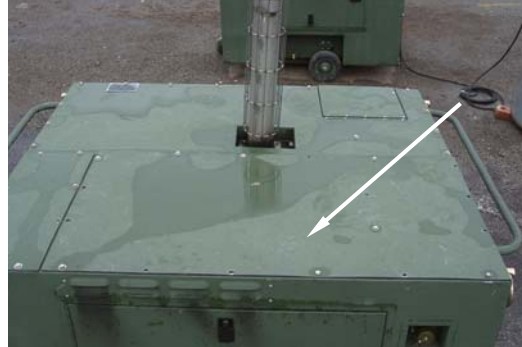

FAN COVER. Removable top cover over the engine bay that permits access to the fan for maintenance or servicing.

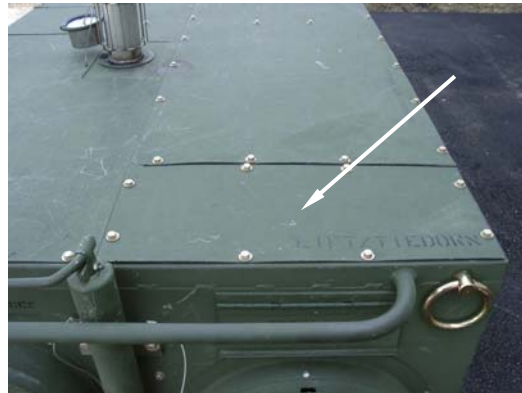

CABINET MOUNTED CARBON MONOXIDE DETECTOR. The cabinet mounted carbon monoxide detector is located just under the fan cover and is designed to detect any carbon monoxide that could enter the inlet air stream. The carbon monoxide detector performs a self-test during each power up of the LCFH and also features a "Push to Test" button.



DIESEL ENGINE. The diesel engine is located on the air inlet side of the heater and is the powerplant for the LCFH. The diesel engine drives the alternator, producing electricity for the heater control circuitry.

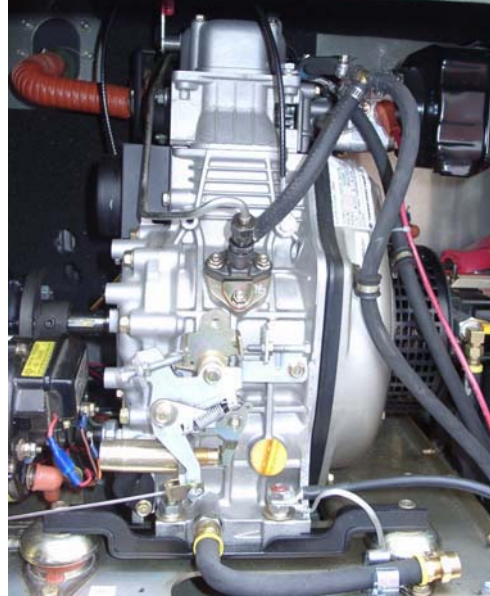

ALTERNATOR. The alternator is located just behind the fresh air inlet and is driven by the diesel engine. The alternator is responsible for generating the power for the control circuitry in the LCFH.



BURNER FUEL PUMP. Located on the diesel engine, the burner fuel pump provides a steady supply of fuel for all burner operations.



BATTERIES. Two 12VDC batteries (24 VDC total) are located behind the engine access door and provide starting energy for the diesel engine. The two batteries were specifically selected for their performance in extreme cold conditions.



FLEXIBLE DRIVE COUPLING. The flexible drive coupling mechanically links and vibrationally isolates the inlet fan from the diesel engine.

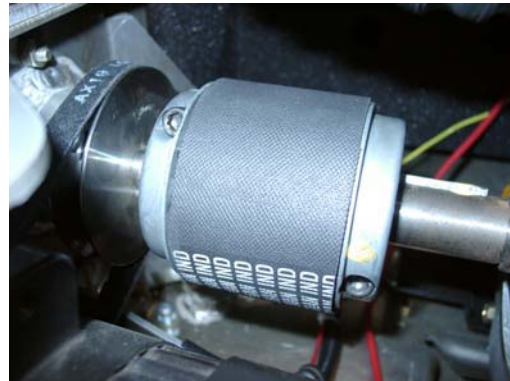

AIR INLET FAN. Located just behind the fresh air inlet air duct, the fresh air inlet fan draws air in from the outside and moves it through the LCFH for heating.



MAIN CONTROL BOX ASSEMBLY.

Located on the interior of the LCFH near the diesel engine, the main control box contains the printed circuit board and other associated circuitry required to operate the heater.



BURNER ASSEMBLY. The burner assembly is designed to be used with a variety of approved military fuels and is located behind the heat exchanger. The burner atomizes and burns the incoming fuel from the fuel pump.



HEAT EXCHANGER. The heat exchanger, positioned on the heated air outlet side of the heater, is designed to transfer the heat generated by the burner to the fresh air being drawn in by the fresh air inlet fan. This is done without mixing any of the combustion gases with the breathable air being made available to the shelter.

NOTE: Heat exchanger access cover removed for illustrative clarity.

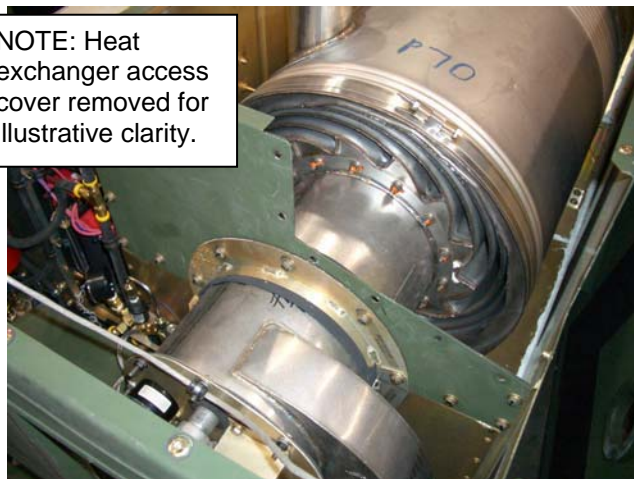

MAIN POWER SHUTDOWN SWITCH.

Permits the operator or maintainer to disconnect the batteries from all internal LCFH circuitry and prevents the heater from being accidentally started during maintenance or servicing.

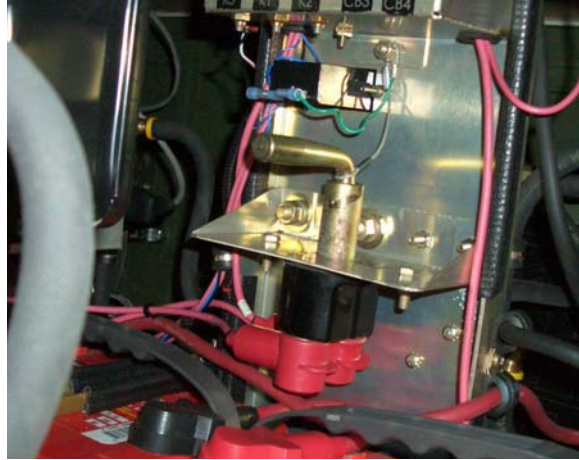

EQUIPMENT DATA

The following technical and identification data pertains to the LCFH and its installation hardware.

Equipment Specification Data

Table 1. EQUIPMENT DATA.	
Manufacturer	Hunter Manufacturing Company
Part number	40000
Operating temperature range	-65°F (-53.8°C) to +65°F(+18.3°C)
Unassisted Starting Temperature	-40°F (-40°C)
Externally Assisted Starting Temperature	-65°F (-53.8°C)
BTUH (maximum)	400,000
Efficiency	82%
Electrical system	24VDC
Air flow	
Heated air (at 225°F [107°C])	2495 ft ³ /minute (70.6 m ³ /minute)
Heater dimensions	
Length	62.0 in (157.5 cm)
Width	44.5 in (113.0 cm)
Height	40.0 in (101.6 cm)
Heater volume	63.86 ft ³ (1.80 m ³)
Heater weight (without accessories)	622 lbs (282 kgs)
Fuel requirements:	
Above +20°F (-6.7°C)	DF-2, DF-1, JP-8
Above -25°F (-33.3°C)	DF-1, JP-8
Above -60°F (-51°C)	JP-8
Fuel tank capacity	35 gallons (132.5 liters)
Fuel consumption	3.72 gph (14.1 lph) (at maximum heat output) 0.2 gph (0.75 lph) (in ventilation-air only mode)
Number hours continuous operation (internal tank only)	8 hours (approx)
Minimum safe distance to combustibles	2 ft (0.6 m)
Batteries	
Quantity	2
Type	Sulfuric Acid, H ₂ SO ₄
Rating	12VDC each
Manufacturer	Optima
NSN	6140-01-475-9361
Diesel Engine Data	
	Unit L70EE
Type	Single-cylinder, vertical-4cycle diesel
Cooling system	— Forced air cooling by flywheel fan

Table 1. EQUIPMENT DATA.

Table 1. EQUIPMENT DATA.			
Combustion system	—	Direct injection system with compression ignition	
Starting system		Starting motor	
Number of cylinder- Bore x Stroke	in (mm)	1 cylinder; 3.07 x 2.51 (78 x 64)	
Displacement	qt (liter)	0.32 (0.306)	
Output Continuous	kW(hp)	4.3(5.8)	
Maximum		4.8(6.4)	
Operational engine speed	rpm	2900	
Compression ratio	—	20.2	
PTO shaft	PTO position	Crank shaft	
	Direction of rotation	Counterclockwise viewed from PTO shaft	
Fuel system	Fuel injection pump	— Bosch type YANMAR PFE-M type	
	Fuel injection timing (FIC:BTDC)	deg 15.0 (±0.5)	
	Fuel injection nozzle	---- VCO nozzle Bosch made	
	Fuel injection pressure	MPa (psi) 19.6 (2842.7)	
	Fuel selection	DF-1, DF-2, and JP-8	
Lubricating oil system	Type of lubrication	— Forced lubrication via trochoid pump: splash lubrication for valve rocker arm chamber	
	Lubricating oil filter	--- Resin, 60 mesh	
	Lubricating oil selection	---	(-50°C to 0°C) MIL-L-46167 Arctic Engine Oil
		---	(-30°C to 10°C) 5W30 A.P.I. Engine Service Classification CC, CD, or CF
		---	(-20°C to 30°C) 10W30 A.P.I. Engine Service Classification CC, CD, or CF
---	(-10°C to 40°C) 20W40 A.P.I. Engine Service Classification CC, CD, or CF		
Lubricating oil capacity full/effective	liter (US quart)	1.1/0.4 (1.2/0.42)	
Air cleaner	---	Paper element filter	
Exhaust silencer	---	Expansion silencer with cover	
Governor	---	All speed type mechanical	
Engine dimensions (Length x Width x Height)	in (mm)	14.1 x 16.6 x 17.7 (358 X 421 X 450)	
Dry mass	lbs (kg)	73.8 (33.5)	
Permissible angle of inclination	deg	20 (30:operating time 3 min. max.)	
Balancer shaft	---	Single shaft	

COMMON TOOLS AND EQUIPMENT

For authorized common tools and equipment, refer to the Modified Table of Organization and Equipment (MTOE), CTA 50-970, Expendable/Durable Items (Except: Medical, Class V, Repair Parts, and Heraldic Items), or CTA 8-100, Army Medical Department Expendable/Durable Items, as applicable to your unit.

Repair parts are listed and illustrated in the repair parts and special tools list located in work packages 0093 00 through 0116 00.

END OF WORK PACKAGE

**OPERATOR, FIELD AND SUSTAINMENT MAINTENANCE
LARGE CAPACITY FIELD HEATER (LCFH)
THEORY OF OPERATION**

General. The LCFH is a heating system that provides clean, heated ventilation air in a military environment and worldwide temperature extremes. The LCFH provides a minimum of 350,000 BTUH of heat and a minimum ventilation airflow rate of 2000 CFM.

Operational Concept. An operational cycle of the Large Capacity Field Heater begins by placing the power switch located on the control panel in the ON position. Once the power switch is engaged, 24VDC power is drawn from the two batteries located in the interior of the LCFH and supplied to all heater subsystems.

The LCFH can be operated from its internal fuel tank or from an external fuel source. The fuel source is selected via a two-position switch located on the operator control box. Fuel for both the diesel engine and the burner fuel pump is drawn through a 10-micron fuel filter which removes any impurities or sediment.

The LCFH utilizes what is referred to as a continuous fuel loop system. As fuel is drawn from the internal fuel tank and supplied to the burner and the engine, some of the unused fuel returns to the internal fuel tank.

When operating in external fuel mode, the LCFH is connected to a bulk fuel supply by means of the external fuel hose. Fuel is drawn from the internal fuel tank until it reaches a low level as determined by the fuel level switch in the fuel tank. At this time fuel will start to be drawn directly from the external fuel source. As fuel from the continuous fuel loop returns fuel to the tank, the level inside the internal fuel tank rises, eventually reaching a point where the fuel level switch triggers a solenoid valve which once again begins drawing fuel from the internal fuel tank. This cycle of drawing fuel from the internal fuel tank and external fuel source continues throughout the operation of the LCFH.

A self test is performed using built-in-test logic designed into the control board. Once all heater subsystems are verified to be within nominal operating limits, the heater enters a startup sequence that varies with outside ambient temperature.

When the startup sequence is complete, fuel is pumped to the diesel engine by the priming fuel pump. Once fuel reaches the diesel engine, a START signal is sent from the control board. If the ambient temperature is -40°F or above, the diesel engine will start unassisted using the two onboard batteries. If the ambient temperature is between -40°F and -65°F , the diesel engine requires additional power supplemented by an external 24VDC source connected to the slave connector on the side of the heater.

Once the diesel engine starts, it drives a belt driven alternator which takes over internal power generation and recharges the batteries for the next startup cycle.

The diesel engine crankshaft is directly coupled to the burner fuel pump which provides fuel to the burner nozzle. A combustion fan provides air to the burner assembly for combustion. Fuel is atomized by the burner nozzle and ignited by the two electrodes.

Heat generated by the burner assembly heats the interior of the heat exchanger which in turn heats fresh air which is drawn into the sealed heated air compartment via a fresh air inlet fan which is connected to an isolated rubber coupling.

All combustion gases created by the diesel engine or the burner assembly are exhausted out through a stowable exhaust stack.

Heated air from the heat exchanger is then forced out the heated air outlet and into the outlet air duct. The outlet air duct delivers heated air from the LCFH to the shelter.

The LCFH can operate in three different modes: manual (MAN), ventilation air only (VENT), and automatic (AUTO). In Manual mode, the heater senses temperature via a sensor located at the heated air outlet and maintains a pre-determined set temperature (225 °F). The heater will then cycle on and off to maintain that temperature. In Ventilation Air Only mode, the diesel engine drives the air inlet fan and delivers unheated air to the shelter. In Automatic mode, the heater reacts to the temperature sensed by the thermistor at the operator control panel. The heater attempts to maintain a set temperature as selected by the operator using the temperature control on the operator control panel.

During heater operation, the operator control panel is hung inside the shelter out of the direct path of the heated air outlet or the cold air from the shelter entrance. If the heater mode switch has been set to AUTO, the thermistor on the control panel monitors the temperature of the shelter interior and sends a signal to the heater that controls the firing of the burner assembly. The burner is then instructed to operate at full heat output, half heat output, or no heat output.

Fault detection circuitry designed into the heater constantly monitors heater status. If a problem should occur, the system will proceed to the shut down mode and then into post purge mode. A fault code will be displayed on the LED display of the operator control panel.

When the heater is to be shut down, the power switch is placed in the OFF position. The heater will then go through a shut down sequence that includes a purge mode to ensure that all residual fumes have been removed from the heater, followed by engine shutdown.

END OF WORK PACKAGE

CHAPTER 2
OPERATING INSTRUCTIONS
LARGE CAPACITY FIELD HEATER (LCFH)

**OPERATOR, FIELD AND SUSTAINMENT MAINTENANCE
LARGE CAPACITY FIELD HEATER (LCFH)
DESCRIPTION AND USE OF OPERATOR CONTROLS AND INDICATORS**

INTRODUCTION

This work package shows the location and describes the use of LCFH controls and indicators. The following illustrations shows the location of the LCFH controls and indicators. You should know the location and proper use of every control and indicator before operating the LCFH. Use this Work Package to learn about each control and indicator and how it works.

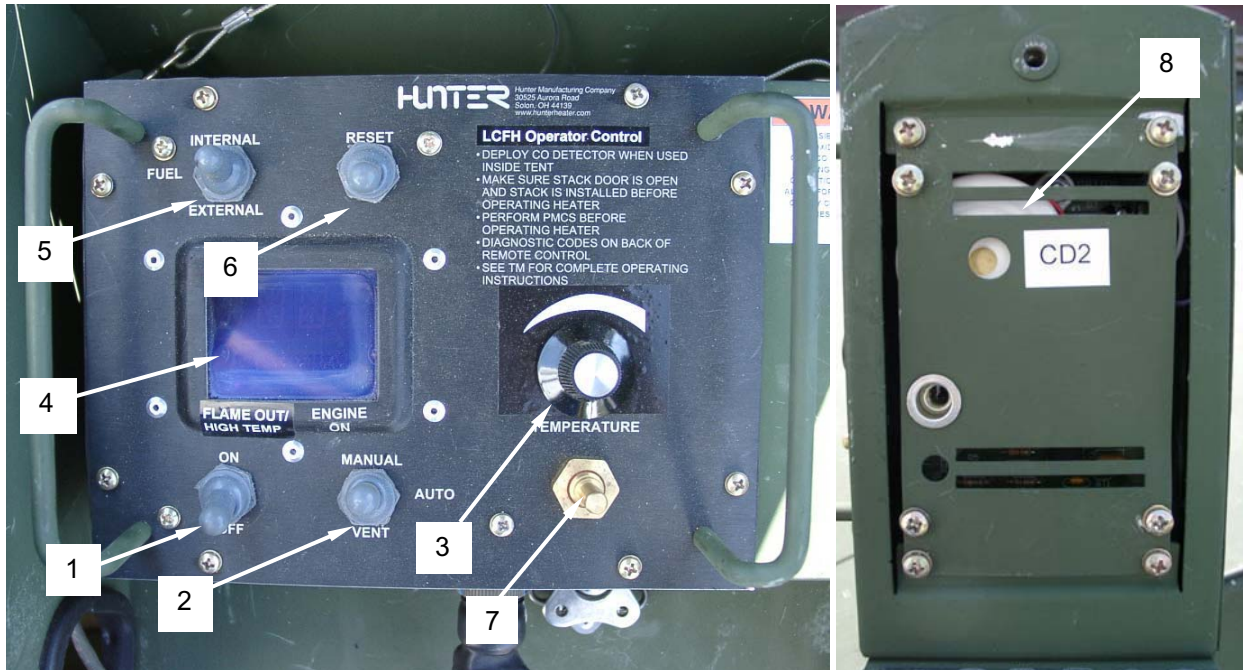

LCFH Operator Control Panel		
Key	Control or Indicator	Function
1	Power	Permits LCFH to be turned on and off.
2	Heater Mode	Offers a choice of three modes of heater operation: MANUAL (provides as much heat as needed, no thermostat control), VENT (no heat, ventilation air only), and AUTO (heat output thermostatically controlled).
3	Temperature	Permits operator to select temperature of shelter.
4	LED Display	Displays system status as well as notice of any system fault codes that may occur.
5	Fuel Selector	Permits selection between external and internal fuel sources.
6	Fault Reset	Spring loaded reset switch to permit heater to be reset after heater fault.
7	Thermistor	Acts as a temperature sensor inside the shelter.
8	Carbon Monoxide Detector	Constantly monitors the air inside the shelter, detects any carbon monoxide that may be present and sounds an audible alarm.

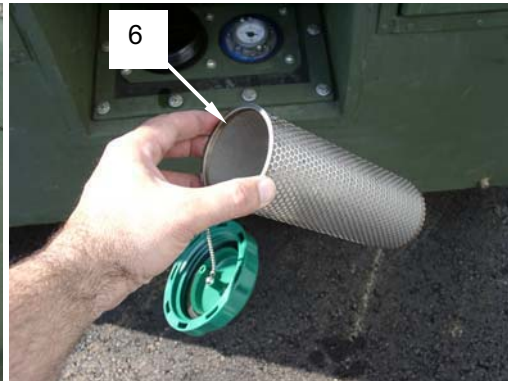
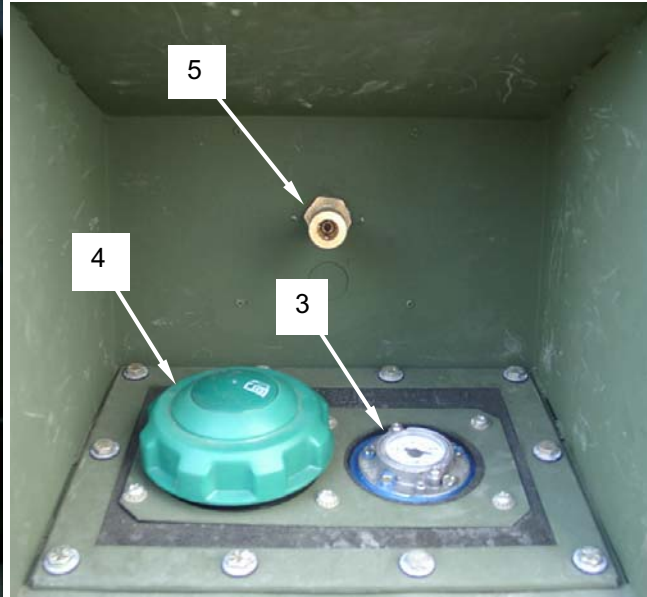

Fuel Service Panel		
Key	Control or Indicator	Function
1	Fuel filter	Filters out any impurities that may be contained in fuel.
2	Fuel Drain	Permits the internal fuel tank to be drained.
3	Fuel gauge	Provides operator with indication of fuel level of internal fuel tank.
4	Fuel Tank Filler Cap	Allows the internal fuel tank to be filled.
5	External Fuel Connector	Permits the connection of an external bulk fuel supply.
6	Fuel tank filler screen	Filters fuel for any solid debris present in the supply.

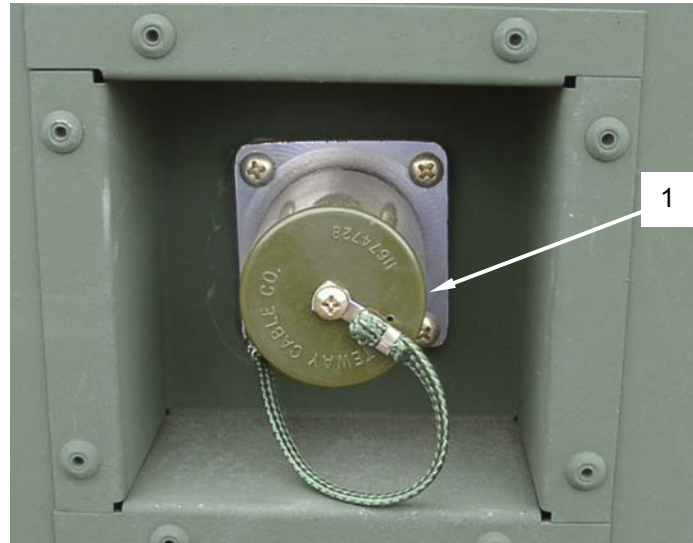

Slave Connector		
Key	Control or Indicator	Function
1	Slave Connector	Allows connection of external 24VDC power to assist in starting between -40°F (-40°C) and -65°F (-53.8 °C). Must not be used to power other vehicles or equipment.

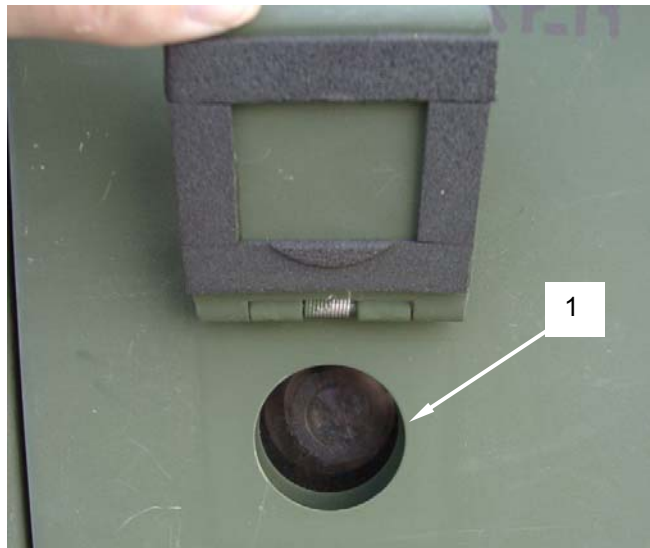

Burner Door Sight Glass		
Key	Control or Indicator	Function
1	Burner Door Sight Glass	Provides the operator with a visual confirmation of burner flame.



LCFH Transport		
Key	Control or Indicator	Function
1	Jack	Permits raising and lowering of front wheel for transport.
2	Retractable Side Wheel	Permits side wheels to be lowered for local mobility or retracted for skid use.
3	Retractable wheel quick release pin	Allows the retractable wheel to be removed quickly to enable raising or lowering. Also permits quick replacement.

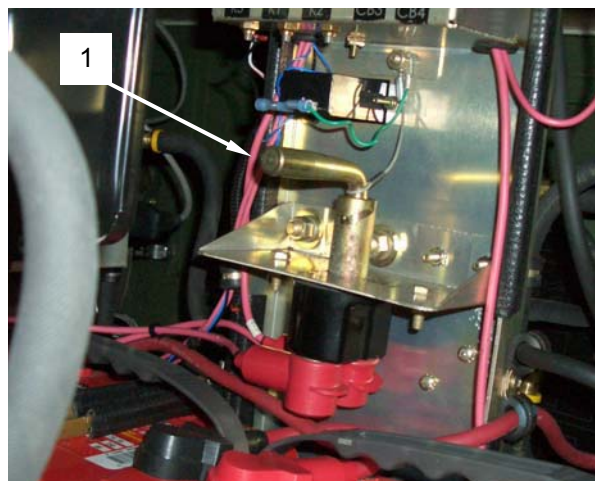

Main Battery Shutdown Switch		
Key	Control or Indicator	Function
1	Main Battery Shutdown Switch	Permits operator or maintainer to disconnect batteries from all internal LCFH circuitry and prevents heater from being accidentally started during maintenance or servicing.

END OF WORK PACKAGE

**OPERATOR, FIELD AND SUSTAINMENT MAINTENANCE
LARGE CAPACITY FIELD HEATER (LCFH)
OPERATION UNDER USUAL CONDITIONS**

SITING REQUIREMENTS**WARNING**

Do not place the LCFH over any fuel and/or electrical lines. Placing the heater over fuel and/or electrical lines may result in electrical shock or fire causing serious injury or death.

**WARNING**

The LCFH should not be positioned any closer than 2 feet from an external bulk fuel supply. Placing the heater closer than 2 feet from a bulk fuel supply may result in fire or explosion causing serious injury or death.

**WARNING**

Do not operate the LCFH near other shelters or enclosures that may not be equipped with carbon monoxide detectors. Exhaust gases from the LCFH may be pulled in by the fresh air intake of nearby shelters or enclosures causing a carbon monoxide hazard. Ensure that the LCFH is placed as far away from other shelters/enclosures as possible. Failure to do so may result in severe injury or death to personnel.

**WARNING**

Hearing protection should be worn when heater is operating with any of the access panels open or closed. Failure to wear ear protection could result in hearing loss or damage.

When positioning the LCFH in preparation for operation, a site should be selected that is:

- Within 12 feet of the duct tunnels installed on the side of the shelter.
- Within 25 feet of an external bulk fuel supply (if used).
- No closer than 2 feet from an external bulk fuel supply (if used).
- Preferably downgrade from the bulk fuel supply to encourage better fuel flow.

- Downwind from the shelter the heater is connected to as well as other surrounding shelters that may not have carbon monoxide detectors installed to prevent combustion gases from the exhaust stack from being blown back into the shelter(s).
- Hardstand or other improved areas; however, any area that is level, free of large holes, trees, debris; properly drained in event of bad weather, and within the guidelines of the Unit Standard Operating Procedure (SOP) is acceptable.

SHELTER REQUIREMENTS

The LCFH is designed to be used with any shelter equipped with duct tunnels that are 16 inches in diameter.

BEFORE OPERATION PMCS

Perform the "Before Operation PMCS" on all LCFH system components as outlined in WP 0010 00, prior to preparing the heater for use. All scheduled maintenance must be performed on the heater and its associated equipment prior to use.

POSITIONING THE HEATER OUTSIDE THE SHELTER

To prepare the LCFH for use, position the heater within 12 feet of the duct tunnels of the shelter using a forklift rated to lift at least 625 pounds.

In order to move the LCFH into the proper position, the side wheels must be deployed and the front wheel lowered to permit local mobility.

NOTE

The LCFH may be safely operated in a wheels deployed (down) condition or with the LCFH resting on its underside skids. The decision to operate with wheels deployed versus on skids is dictated by conditions in the field of deployment.

Lowering the side wheels. Before the LCFH can be transported, or to permit local mobility, the side wheels must be lowered and locked into position.

Lower the front wheel **(1)** by rotating the wheel jack handle **(2)** clockwise until the front wheel **(1)** contacts the ground and begins to tilt the heater back on its snow skids. Continue until the front wheel is completely lowered.

Remove the locking pin **(3)** and remove wheel and axle assembly **(4)**.

Rotate the wheel and axle assembly **(4)** 90 degrees.

Reinstall wheel and axle assembly **(4)** and engage locking pin **(3)**.

Repeat for the opposite wheel.

Raise the front wheel **(1)** by rotating the wheel jack handle **(2)** counterclockwise until the top of the heater cabinet is parallel to the ground. Ensure that the front wheel is positioned to permit free movement of the caster **(5)** or the front wheel will not swivel properly.

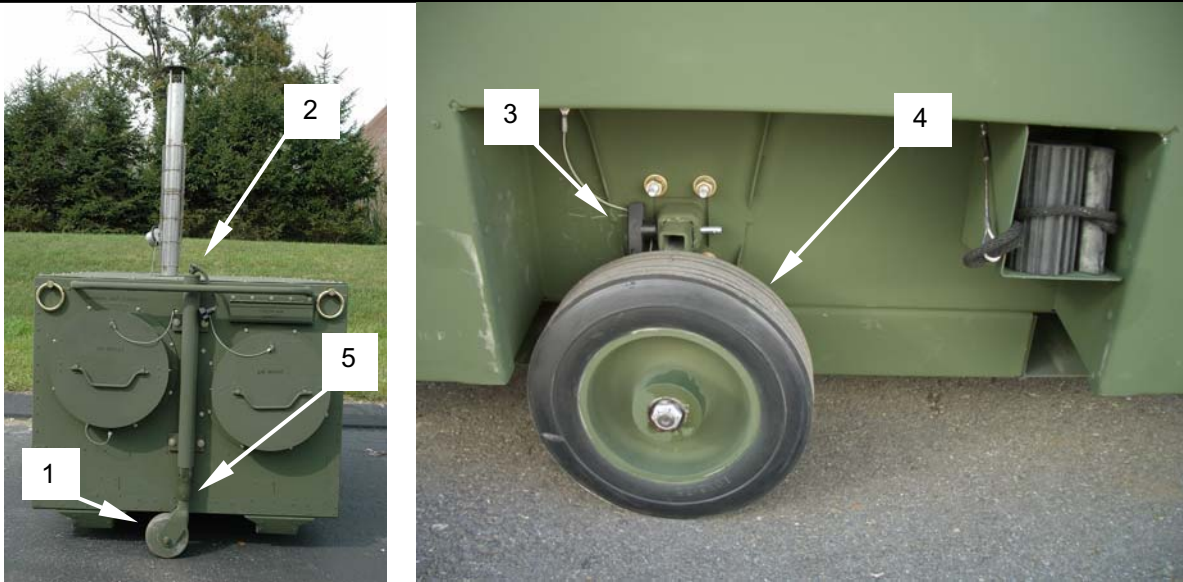

Operating in a wheels deployed condition. Orient the heater so that the air inlet (1) and heated air outlet (2) end of the heater are directed toward the shelter duct tunnels. Position the heater so as to minimize bends in the ducts.

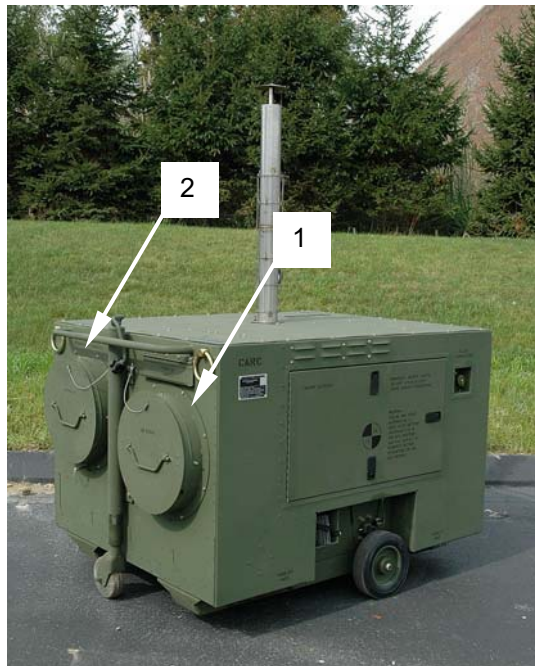

Deploy the wheel chocks. Wheel chocks (1) are provided to prevent the heater from moving once positioned. Remove the wheel chocks (1) from their storage location (2) next to each wheel (3). Position a chock in front of and behind each wheel. Ensure that the wheel chocks are secure under the wheel so they will not move.

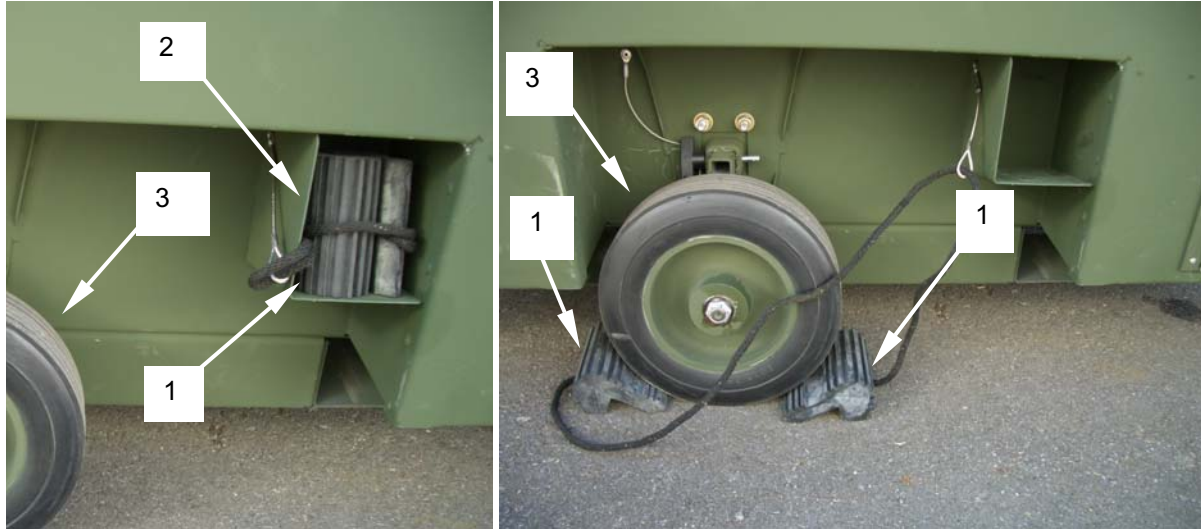

ASSEMBLY AND PREPARATION FOR USE

Removing the inlet and outlet duct covers. Remove the outlet duct cover (1) protecting the heated air outlet (2) by grasping the handle (3) and pulling upward to disengage the locking clips (4). Pull straight out from the heater.

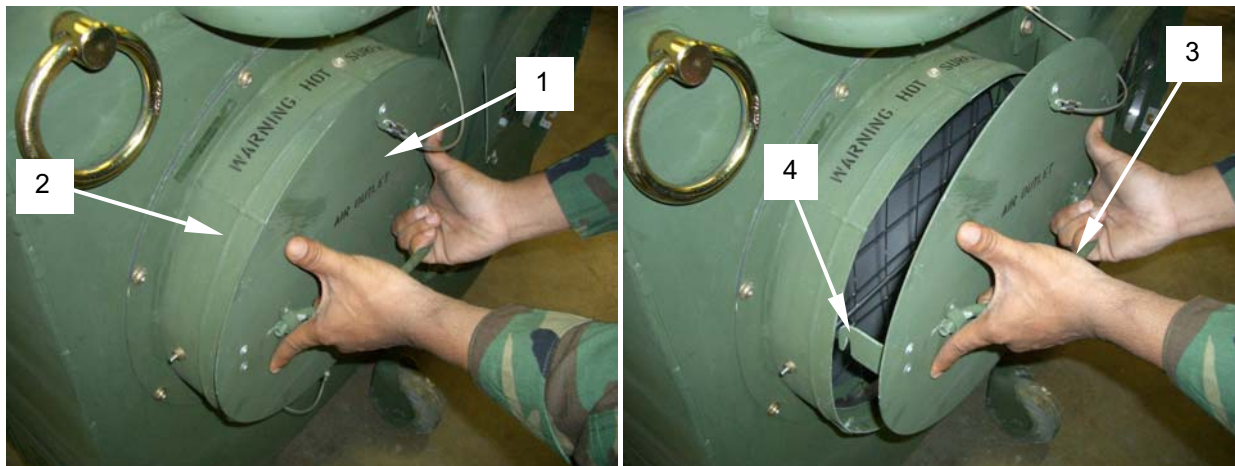

Remove the inlet duct cover (5) by grasping the handle (6) and pulling straight up until the locking clips (7) disengage from the rod (8) that spans across the inlet duct opening (9).

Both duct covers are attached to the heater with wire lanyards (10) to retain them to the heater when not in use.

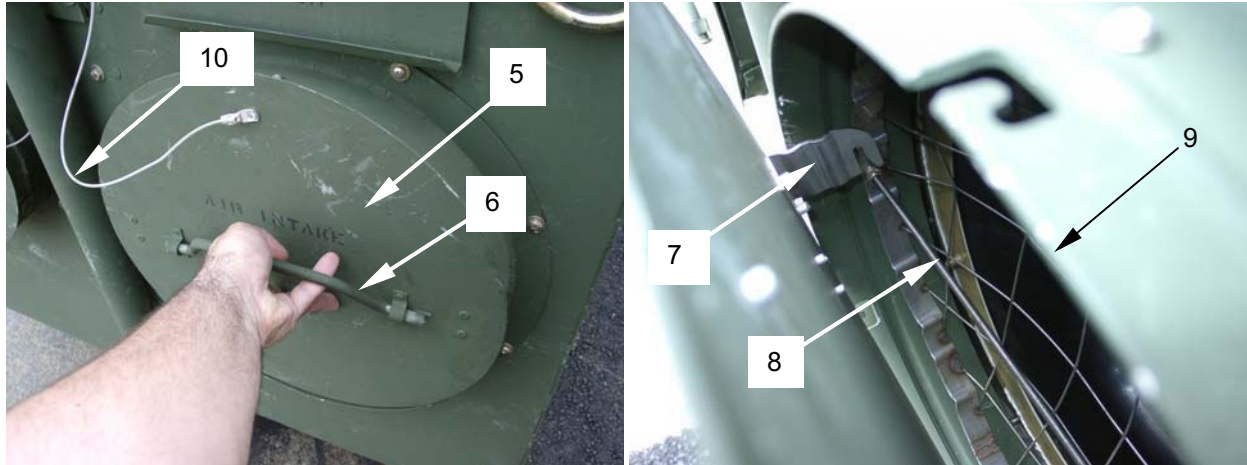

Installing the Flexible Ducts.



WARNING

Gloves should be worn to protect against cuts and/or pinched fingers. Failure to do so could result in injury to hands.

Disengage the internal stowage hook of both flexible ducts and expand the ducts to their full length.

The ducts themselves are identical but can only be connected to the inlet and outlet ducts in one way. Air flow direction tags are mounted to each duct to indicate the direction of air flow. The inlet duct collar is outfitted with slots that accommodate pins on one duct. The outlet duct collar is outfitted with pins that protrude inward to accommodate slots on the opposite end of the second duct.

To install the inlet or outlet duct (1) on the heater, push the duct end ring (2) into the duct opening (3) on the heater so that the slots (4) on the end ring (2) engage with the pins (5) protruding from the inside of the duct opening (3). Rotate the end ring (2) counterclockwise and pull until it locks in place. The air flow direction of the inlet and outlet ducts are tagged on the duct. They are oriented opposite to one another and can only be connected to the heater duct collars in one way. Repeat for second duct.

Install the opposite ends of the ducts into the duct tunnels on the shelter.

Secure the tent duct tunnel ties to seal the ducts in the tent duct tunnels.

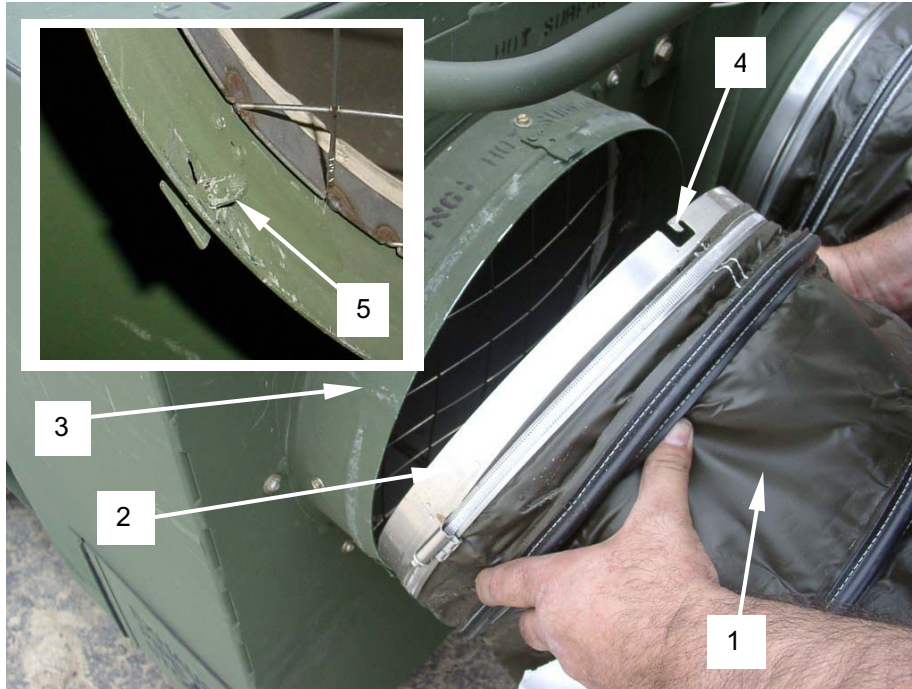

Deploying the exhaust pipe. To deploy the exhaust pipe (1), open the exhaust pipe stowage door (2) and remove the exhaust pipe (1). Secure the stowage door (2).

Remove the cap (3) from the exhaust pipe port (4) and set aside.

Align the cutout (5) in the exhaust pipe with the pipe in the exhaust pipe port. Install the exhaust pipe (1) into the exhaust pipe port (4) until firmly seated.

Stow the cap (3) on the exhaust pipe guard (6) using the S-hook (7) provided.

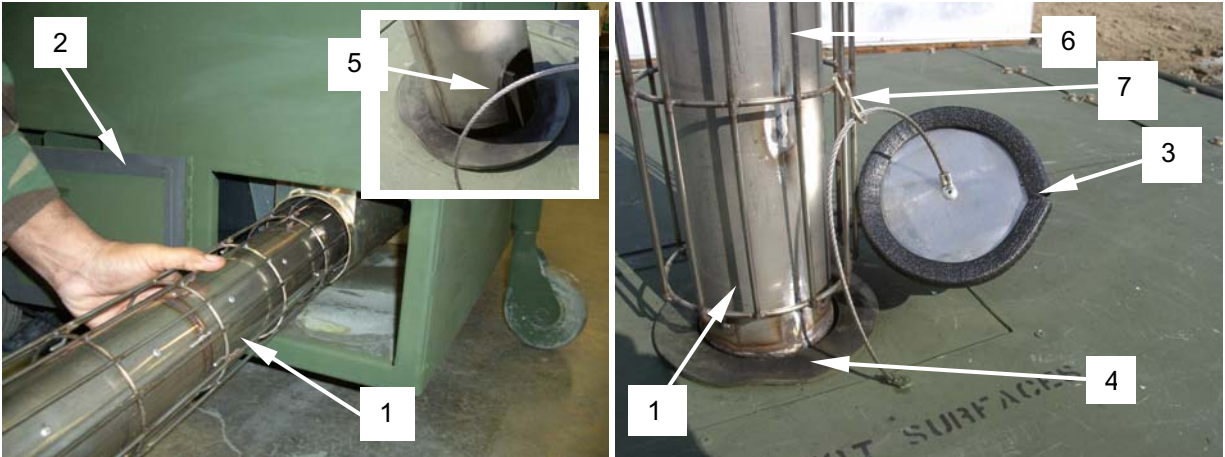

Installing the operator control box in the shelter. To install the operator control box in the shelter, open the operator control box cover (1) on the top of the heater.

Unwind the 25-foot control cable (2) to gain access to the operator control panel.

Remove the operator control box (3) from its stowage location by releasing the single turn-key latch (4) and lifting upward.

Slide the operator control box (3) and attached cable (2) under the side of the shelter in a convenient location that will not hinder entry or exit from the shelter or act as a trip hazard. Take care not to get any dirt or debris on the operator control box.

Hang the operator control box (3) inside the shelter at a height of three to six feet using the attached cable (5). Place the operator control box (3) in a location that is not in the direct path of air coming from the heated air outlet duct or in the direct path of cold air entering from the shelter entry.

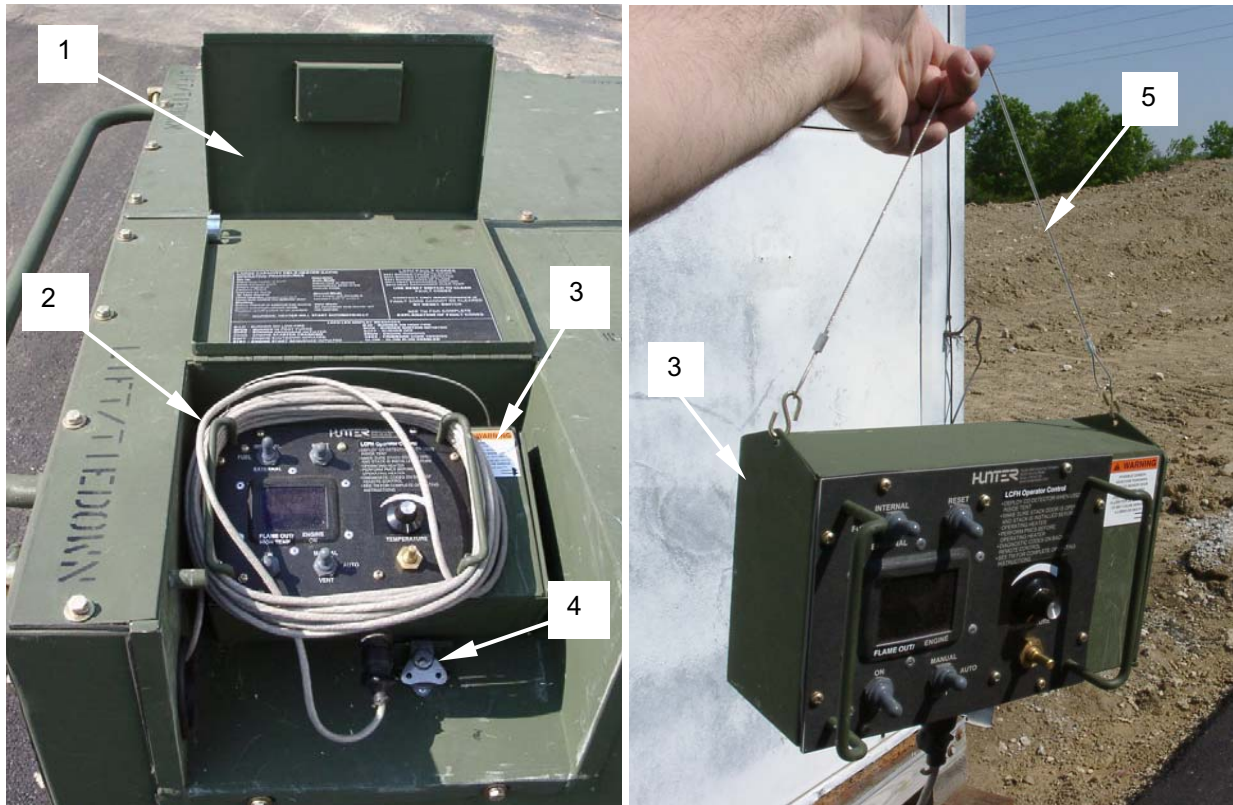

Deploying the carbon monoxide detector.**NOTE**

The detector is only rated for operation above 32°F. The carbon monoxide detector will survive -65°F cold storage.

To deploy the carbon monoxide (CO) detector (1) on the operator control box (2), unscrew the small thumb screw (3) on the cover (4) protecting the CO detector (1). Open the cover (4) and allow it to hang below the CO detector.

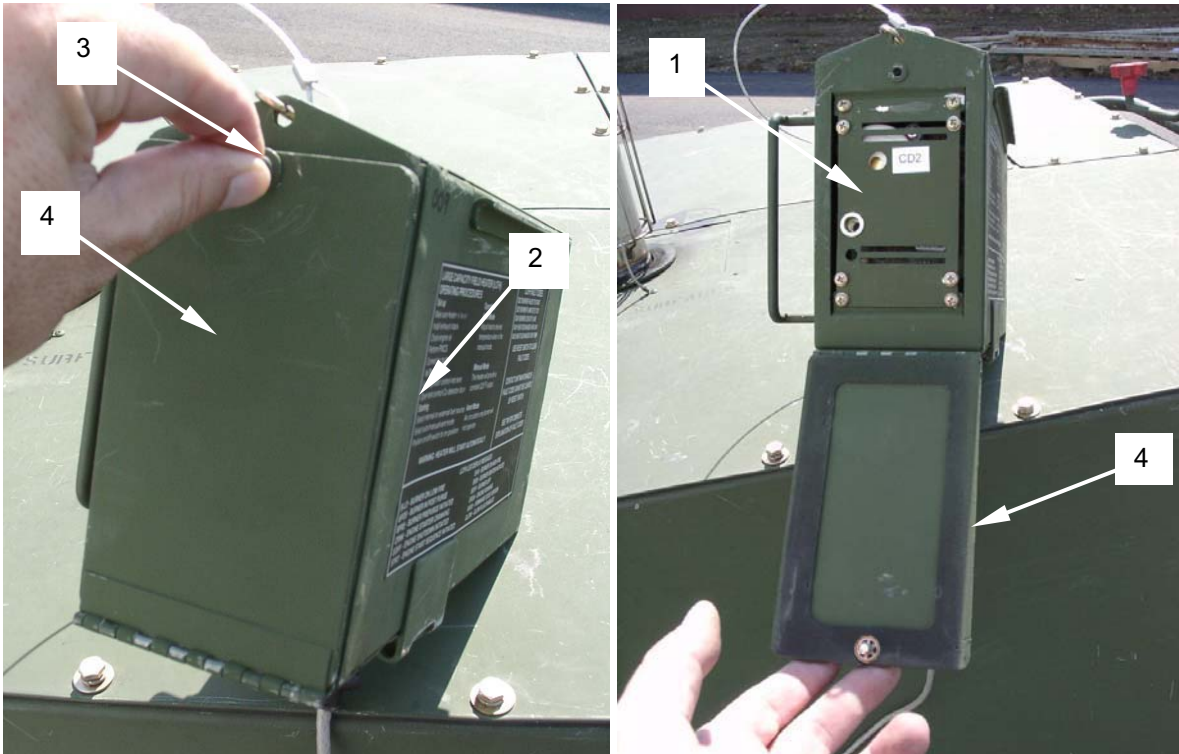

FUELING THE LCFH**WARNING**

Do not use unauthorized fuels! Use of unauthorized fuel may result in fire/explosion causing severe injury or death.

Fueling the internal fuel tank.**NOTE**

Be sure to place a petroleum absorbent material or mat under the fuel panel to catch any fuel that may spill or drip during the fueling operation. Be sure to dispose of the soiled material and/or mat in accordance with unit SOP and local environmental regulations.

Be sure to rotate the fuel can when filling the LCFH internal fuel tank to ensure that the fuel can is completely empty.

To fill the internal fuel tank **(1)** with an approved fuel as listed in WP 0002 00, remove the fuel filler cap **(2)** on the rear of the heater.

Fill the fuel tank with approved fuel until the fuel can be seen just below the filler neck. The LCFH fuel tank has a capacity of 35 gallons.

When the tank is full, replace the fuel filler cap **(2)** and tighten securely. The fuel level in the tank is constantly displayed on the fuel gauge **(3)**.

Wipe up any spilled fuel with a wiping rag. Dispose of soiled rags and/or or petroleum absorbent mat in accordance with local environmental regulations.

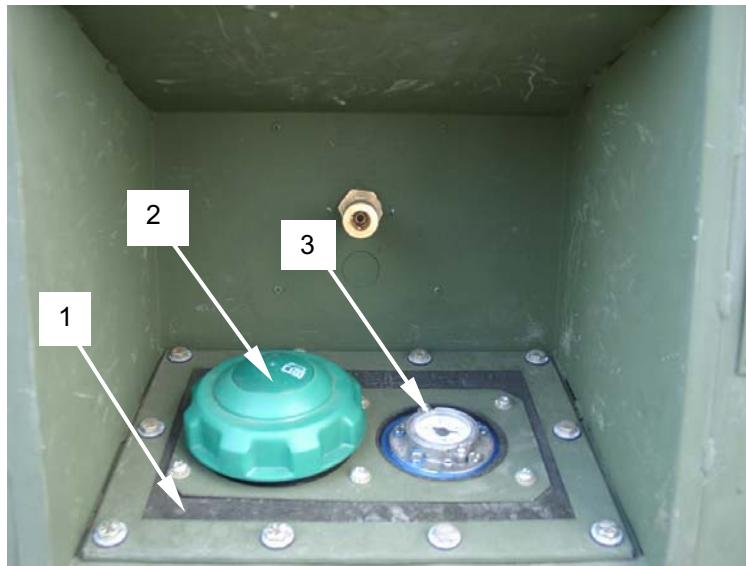

Operating from an external fuel supply.**WARNING**

The LCFH should not be positioned any closer than 2 feet from an external bulk fuel supply. Placing the heater closer than 2 feet from a bulk fuel supply may result in fire or explosion causing serious injury or death.

**WARNING**

The external fuel connection should not be used if the internal fuel tank is ruptured or otherwise leaking as the fuel system utilizes a continuous fuel loop-back design. Using the external fuel connection when there is a rupture or leak in the internal fuel tank may result in fire or explosion causing severe injury or death.

**WARNING**

Hearing protection should be worn when heater is operating with any of the access panels open or closed. Failure to wear ear protection could result in hearing loss or damage.

CAUTION

The external fuel supply should be located no more than 25 feet from the heater as the external fuel hose is 25 feet in length. The external fuel hose must not be lengthened by adding additional sections as this may place additional demands on the electrical fuel pump in the heater.

NOTE

The external fuel supply should be placed slightly uphill from the LCFH to aid in fuel flow.

NOTE

The LCFH can be switched from internal to external fuel mode (or vice versa) while the heater is operating. However, if the internal fuel tank is very low on fuel or empty, there may be a period of time when the heater sputters or runs erratically while air is purged from the external fuel hose. Allow the heater to run until all air is expelled and the heater resumes normal operation. A discussion on the operation of the fuel supply can be found in WP 0003 entitled Theory of Operation.

To operate the LCFH from an external fuel source, retrieve the 25-foot external fuel hose (1) from its storage location on the inside of the engine access panel (2). Close engine access panel after the hose has been removed.

Remove the dust cap (3) from the male quick disconnect end (4) of the external fuel hose (1).

Connect the male quick disconnect end (4) of the 25-foot external fuel hose (1) to the external fuel connector (5) located on the fuel filler panel (6) at the rear of the heater. Push back the outside collar of the external fuel connector, insert the male quick disconnect end and ensure that it is fully seated, and release the outside collar. Pull on the external fuel hose to ensure a secure connection.

To connect the opposite end of the external fuel hose (1) to a bulk fuel supply, first remove the dust plug (7). Connect the opposite end of the external fuel hose (1) equipped with a 5/16 JIC female flair fitting (8) to the bulk fuel supply. Be sure to place a petroleum absorbent mat or tray containing petroleum absorbent material under both connections.

Once the connection has been made between the LCFH and the external fuel supply, place the FUEL selector switch in the EXTERNAL position as described in the section of this work package entitled INITIAL OPERATOR CONTROL BOX SETTINGS.

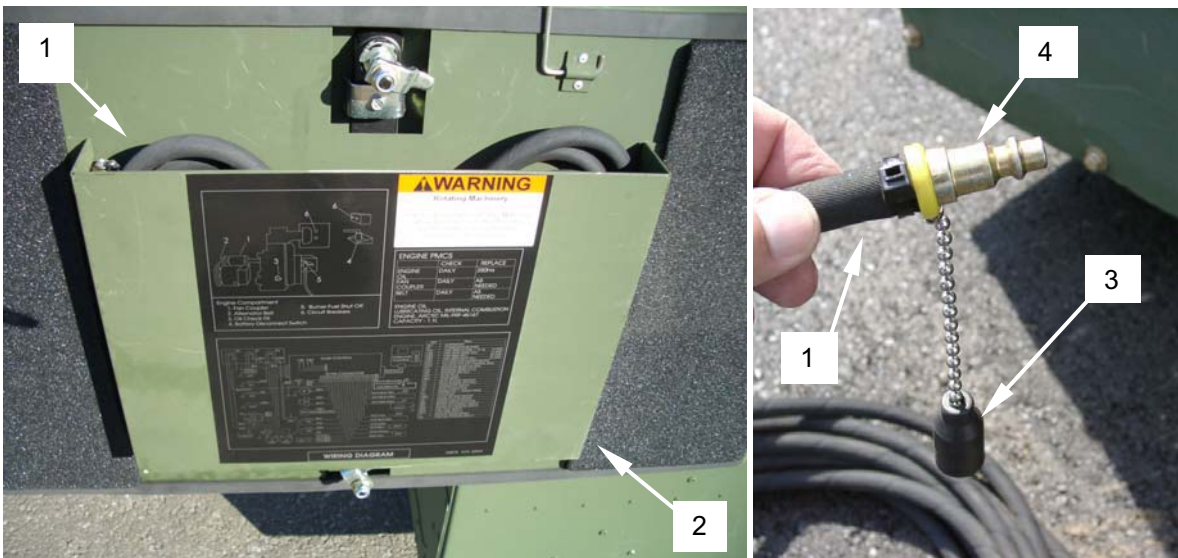

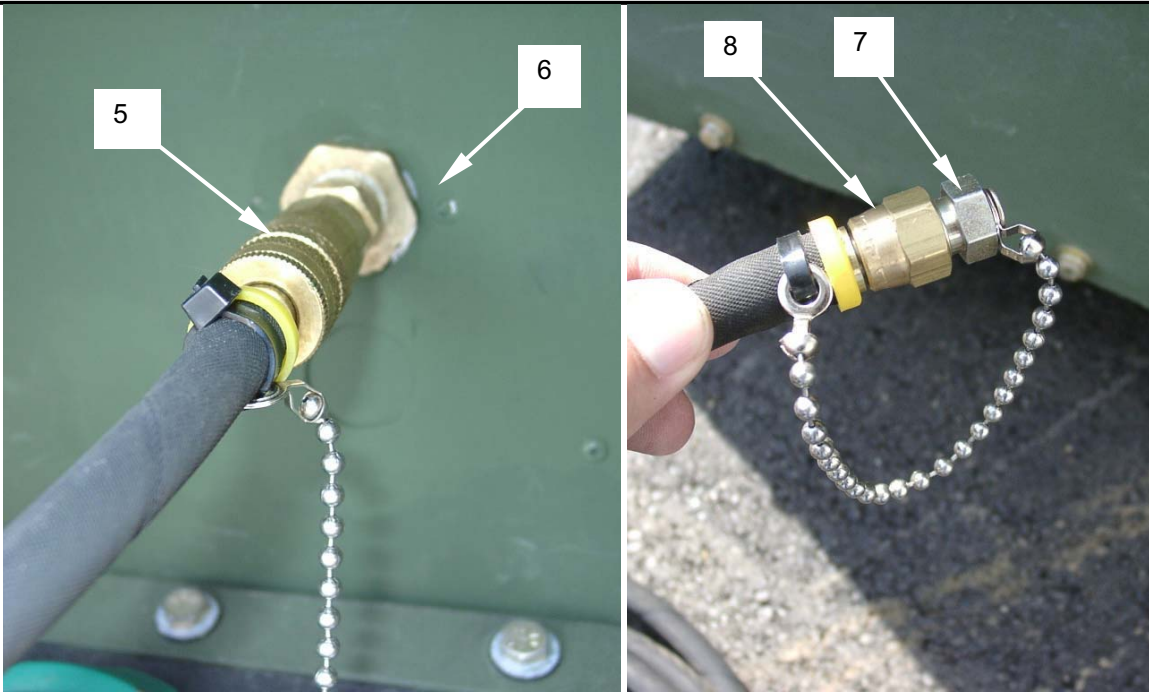

INITIAL OPERATOR CONTROL BOX SETTINGS

Before powering up the LCFH, the controls on the operator control box **(1)** need to be set in the appropriate positions as follows.

If the heater is to be operated using the internal fuel tank only, place the fuel selector switch **(2)** in the INTERNAL position. If the heater is to be operated using an external fuel supply, place the fuel selector switch in the EXTERNAL position.

Determine whether the heater will be operated in MANUAL, VENT, or AUTO mode. Place the operating mode switch **(3)** in the desired position. In MANUAL mode, the heater will continue to generate heat continuously until shut down. Heat output is not regulated by the thermistor **(4)** in the operator control box. In VENT mode, the heater will not generate heat and will blow fresh, unheated air into the shelter. In AUTO mode, the heat output of the LCFH is regulated by the temperature control **(5)** on the operator control box and the installed thermistor **(4)**. When the temperature in the shelter reaches the temperature preset on the operator control box, the heater will either shut down, go into half heat output mode, or go into full heat output mode.

If the heater is to be operated in AUTO mode, set the temperature control **(5)** on the operator control box to the desired position.

Once all controls on the operator control box are in the desired positions, the heater can now be powered up as detailed in the section to follow.

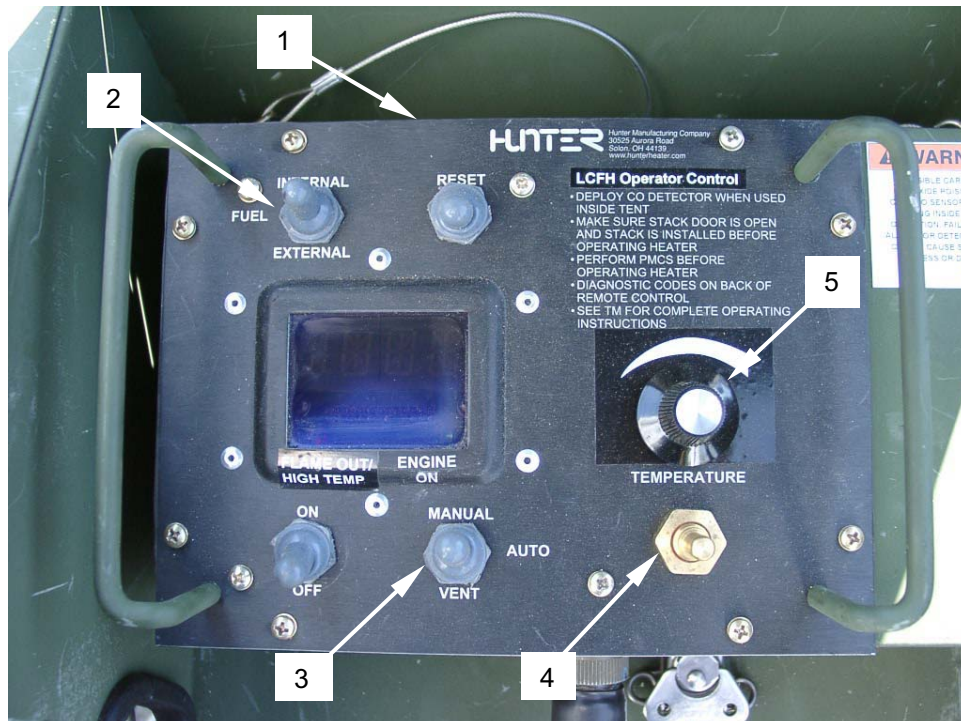

OPERATING PROCEDURES

Ensure that all operator control box selector switches have been placed in the appropriate operational positions as described in the previous section entitled "Initial Operator Control Box Settings".

CAUTION

Once the power switch is placed in the ON position, be sure to wait the prescribed time as indicated in Table 1. Do not turn the power switch on and off until sufficient time has elapsed. Heat will not be supplied until after the initial startup time has passed and turning the power switch on and off will cause the LCFH to cycle and restart the startup process.

**WARNING**

Hearing protection should be worn when heater is operating with any of the access panels open or closed. Failure to wear ear protection could result in hearing loss or damage.

NOTE

If the outside temperature is -40 degrees F or lower, connect the slave connector on the side of the heater to a 24VDC power source such as from a humvee or cargo truck. At these temperatures, the internal batteries in the LCFH may require supplemental power to permit heater startup. The slave connector is not to be connected to other equipment.

When operating at a 10 degree or greater angle, the oil pressure fault code may come on if the system is starved for oil.

NOTE

Be sure to perform all Before Operation PMCS IAW WP 0010 before starting and using heater.

NOTE

Ensure that the power switch on control panel is in the OFF position. Open engine access door and ensure that the main battery shutdown switch (1) is in the ON position before operating heater. Be sure to close the engine access panel before starting. Perform a walkaround of the heater before starting to ensure that the heater is completely ready for startup.

To start the heater, place the power switch (2) on the operator control box to the ON position. The heater will perform a series of self tests that will be summarized on the LED display on the operator control box. If any faults are detected during the startup sequence, the system startup will be aborted and the fault code shown on the operator control box display. If the startup system is aborted and a fault code displayed, refer to work package 0008 00 for reference to appropriate troubleshooting procedures.

Once the self test is complete, the heater will enter its startup procedure. The amount of time required for the startup sequence to complete is dependent on the outside ambient temperature. Table 1 provides an approximation of startup time versus outside temperature.

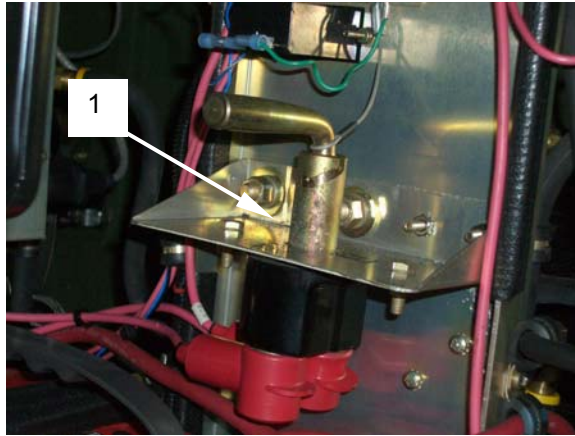

Table 1. LCFH Startup Time versus Outside Ambient Temperature.

LCFH STARTUP TIME	OUTSIDE TEMPERATURE
2 minutes	above 32°F (0°C)
3 minutes	32°F to 0°F (0°C to -17.8°C)
4 minutes	0°F to -30°F (-17.8°C to -34.4°C)
5 minutes	-30°F to -65°F (-34.4°C to -53.9°C)

During the startup sequence, a series of startup codes will be displayed on the operator control panel. Table 2. lists the codes and their meaning.

Table 2. LCFH Startup Codes.

CODE	DESCRIPTION	CODE	DESCRIPTION
B-LO	Burner on low fire	B-HI	Burner on high fire
BPOS	Burner in post purge	BIGN	Burner ignition initiated
BPRE	Burner prepurge initiated	BOFF	Burner off
CRNK	Engine starter cranking	ERUN	Engine running
EOFF	Engine shutdown initiated	VXXX	Firmware code version (XXX replaced with numbers)
STRT	Engine start sequence initiated	GLOW	Glow plug enabled

As the startup sequence progresses, the system will go through a fuel system purge sequence and the glow plug on the diesel engine will be preheated.

The diesel engine start sequence will begin which may involve multiple start attempts depending on the outside temperature.

Once the diesel engine has started and has stabilized, the burner fuel pre-purge sequence will begin.

When the burner pre-purge sequence is complete, the burner will start. The burner may require multiple start attempts depending on the outside temperature.

Once the burner has fired, the LED display on the operator control box will indicate either "B-LO" (burner in lo fire) or "B-HI" (burner in high fire) indicating that the system is running.

After a short time, the heater will begin sending heated air into the shelter.

Operating the Carbon Monoxide Detector



WARNING

Actuation of the carbon monoxide detector indicates the presence of CO which can be FATAL. Operate LCFH in a well ventilated area, away from any openings. Failure to do so can result in serious injury or death.

If alarm sounds:

1. Immediately move to a location which has fresh air, outdoors or by an open door/window.

DO A HEAD COUNT TO CHECK THAT ALL PERSONS ARE ACCOUNTED FOR. DO NOT REENTER PREMISES UNTIL THE MEDICAL PERSONNEL HAVE ARRIVED, THE PREMISES HAS BEEN AIRED OUT, AND THE ALARM REMAINS IN ITS NORMAL CONDITION.

2. Call for medical support personnel.
3. Press the reset button **(1)**. After following steps 1 and 2, if your alarm reactivates within a 24-hour period, repeat steps 1 and 2 and contact unit maintenance to examine and/or replace the detector.

When the power switch on the operator control box is turned on, the status light **(2)** on the front of the carbon monoxide detector **(3)** will alternately switch between RED and GREEN, as the unit performs a two and a half minute warm-up and self-test procedure.

The audible tones on the detector will cycle twice, emitting two sets of four tones. At the end of this 2-1/2 minute cycle, the status light **(2)** will turn GREEN to indicate normal operation and good, safe air. The alarm relay is energized during the 2-1/2 minute warmup cycle.

The CO detector continuously monitors the air in the shelter. If the detector measures levels of CO greater than the danger level, the RED light will turn on, the Alarm Relay will switch to actuate the alarm circuits in the operator control box, the buzzer will sound, and the heater will shut down. The detector is programmed to alarm if the danger level of carbon monoxide is exceeded, which are time and concentration related. The alarm points are 70 ppm of carbon monoxide after 60 to 240 minutes, 150 ppm of CO after 10 to 50 minutes, and 400 ppm of CO after 4 to 15 minutes, per UL Standard 2034.

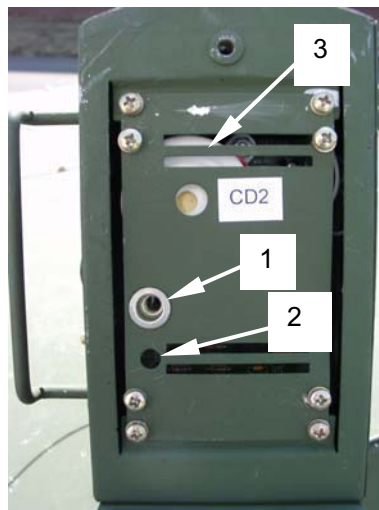

OPERATING THE FRESH AIR DAMPER

The fresh air damper (1) permits outside air to be introduced into the inlet air stream of the LCFH. This makeup air allows fresh air to mix with the air that is being circulated inside the shelter.

To deploy the fresh air damper, lift the damper door and engage the spring loaded prop (2) into one of the holes under the damper door.



SHUTDOWN PROCEDURE

To shutdown the LCFH, place the power switch (1) in the OFF position.

Once the heater has been instructed to shut down, the burner will be shut down followed by a burner post-purge and cooldown. This is in turn followed by a burner fan shut down and a shutdown of the diesel engine.

The entire shutdown process for the heater is estimated at three to five minutes but may vary depending on conditions.

Once heater is shutdown and cool, open the engine access panel and turn the main battery shutdown switch to the OFF position. Close the engine access door.

Once the heater has been successfully shut down, it should be maintained as outlined in work package 0010 00 entitled Preventive Maintenance Checks and Services.



DECALS AND INSTRUCTION PLATES

The following instruction and/or warning plates can be found on the LCFH:

INSTRUCTION/WARNING PLATE	
<p>LARGE CAPACITY FIELD HEATER(LCFH) OPERATING PROCEDURES</p> <p>Set up Make sure heater is level Install exhaust stack Check engine oil Perform FMCS Connect air ducts</p> <p>In Tent Control Feed operator control into tent Open tent control Co Detector door</p> <p>Starting Select internal or external fuel source Select auto/manual/vent mode Position on/off switch to on position</p> <p>WARNING: HEATER WILL START AUTOMATICALLY</p>	<p>Operation Auto Mode Adjust heat to desired temperature when in the auto mode</p> <p>Manual Mode The heater will provide a constant 225°F output</p> <p>Vent Mode Air circulation only burner will not operate</p> <p>LCFH FAULT CODES S221 BURNER FAILED TO START S231 BURNER FLAME DETECTED S241 BURNER LOSS OF FLAME S411 HEAT EXCHANGER AIRFLOW S412 HEAT EXCHANGER OVER TEMP</p> <p>USE RESET SWITCH TO CLEAR FAULT CODES</p> <p>CONTACT UNIT MAINTENANCE IF FAULT CODE CANNOT BE CLEARED BY RESET SWITCH</p> <p>SEE TM FOR COMPLETE EXPLANATION OF FAULT CODES</p> <p>LCFH LED DISPLAY MESSAGES</p> <p>B-LO - BURNER ON LOW FIRE BPOS - BURNER IN POST PURGE BPRE - BURNER PREPURGE INITIATED CRNK - ENGINE STARTER CRANKING EOFF - ENGINE SHUTDOWN INITIATED STRT - ENGINE START SEQUENCE INITIATED</p> <p>B-HI - BURNER ON HIGH FIRE BIGN - BURNER IGNITION INITIATED BOFF - BURNER OFF ERUN - ENGINE RUNNING YXXX - FIRMWARE CODE VERSION GLOW - GLOW PLUG ENABLED</p>

DESCRIPTION/LOCATION
 Operating instructions for heater. Identical instruction plates located under operator control box cover on top of heater and on rear of operator control box.



Warning label near exhaust stack port indicating that exhaust stack is a hot surface during operation. Located on top cover near exhaust stack access door.

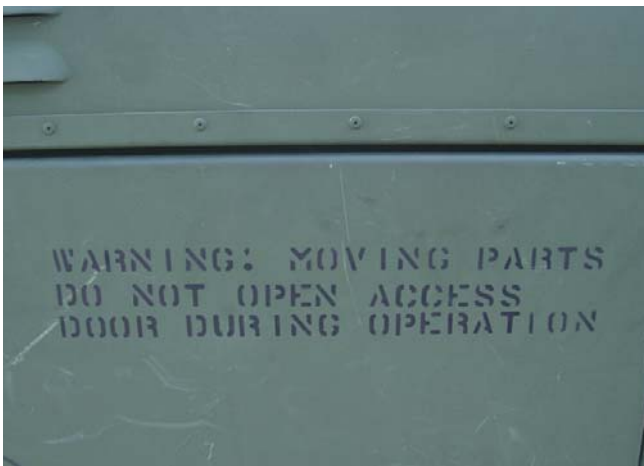

Warning label indicating that the engine access door is not to be opened during heater operation. Located on upper right corner of engine access door.

INSTRUCTION/WARNING PLATE

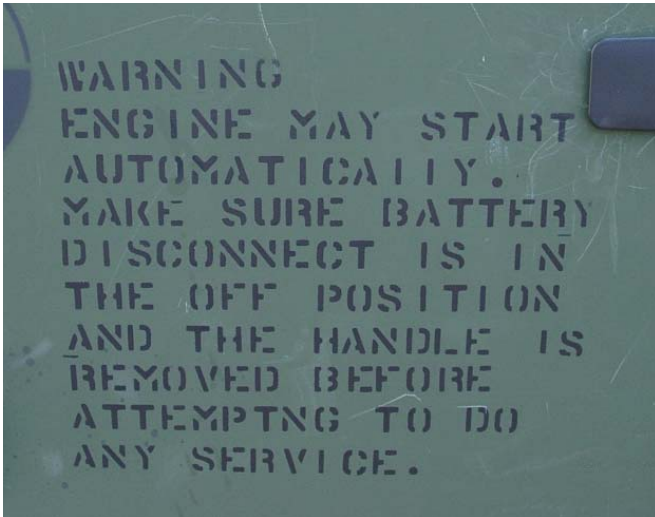

DESCRIPTION/LOCATION

Warning label indicating that the engine may start automatically and that main battery switch must be set in the off position and removed prior to conducting any service inside the engine compartment. Located on engine access door.

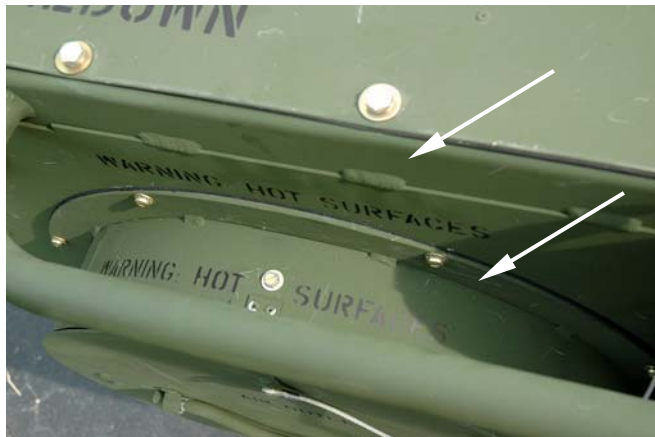

Warning labels located above heated air outlet alerting operator of hot air in excess of 225°F at heated air outlet when heater is in operation.



Air Inlet label showing the location of air inlet duct connection. Located on surface of air inlet duct cover.

INSTRUCTION/WARNING PLATE

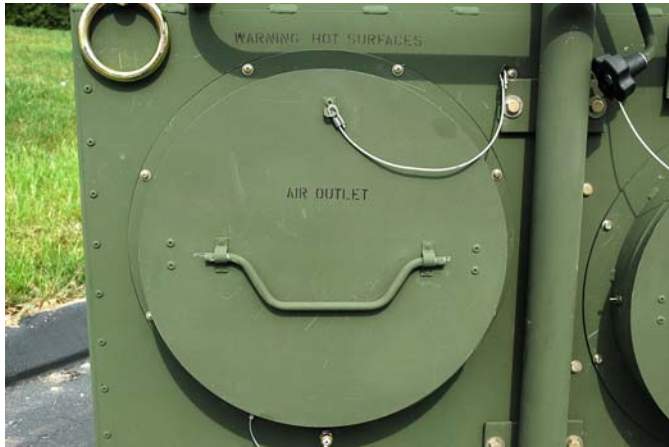

DESCRIPTION/LOCATION

Air Outlet label showing the location of air outlet duct connection. Located on surface of air outlet duct cover.



Fresh Air Damper label located on the surface of the fresh air damper.



LCFH Data Plate located on the engine access door side of the heater at upper left corner of the heater containing information pertinent to the serial number, model number, NSN, etc.

INSTRUCTION/WARNING PLATE



DESCRIPTION/LOCATION

Carbon Monoxide Detector deployment warning label located on lower right of operator control box alerting operator to deploy the carbon monoxide detector on the operator control box before using the heater.

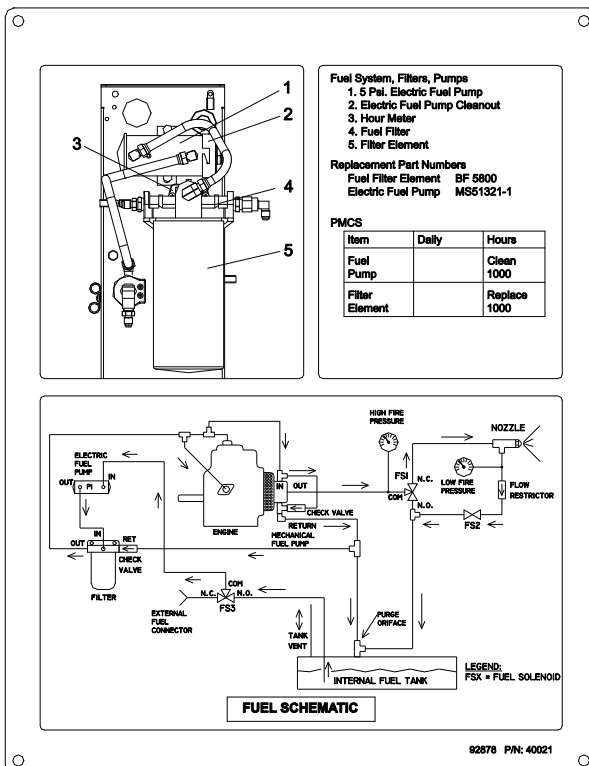

Fuel system schematic. Located on inside of fuel access door.

INSTRUCTION/WARNING PLATE

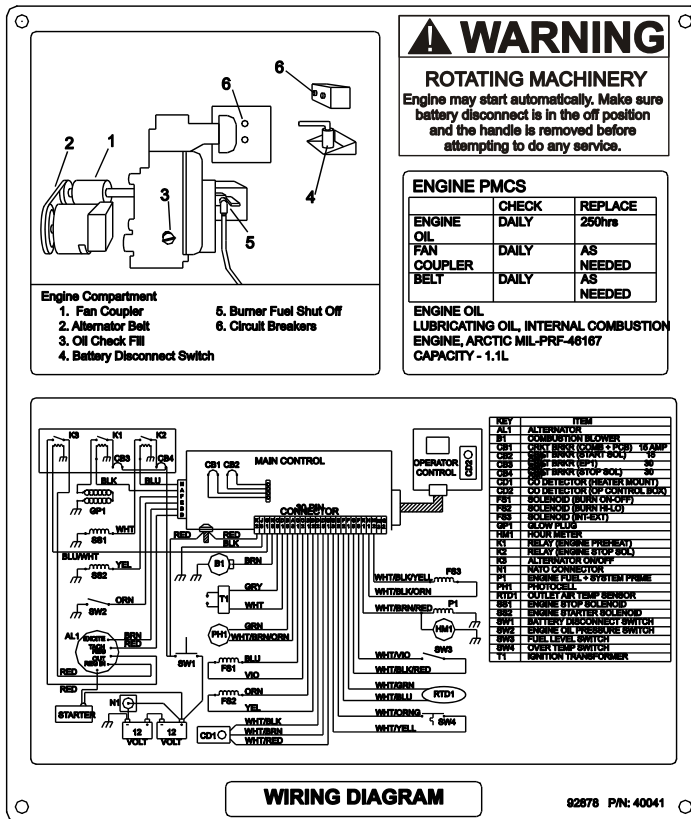

DESCRIPTION/LOCATION

Electrical wiring diagram and schematic of main engine components. Also contains WARNING label for Rotating Machinery. Located on inside of engine access door.



Placard above fuel access panel indicates authorized fuels and temperature ranges at which they should be used. Also, warning to use authorized fuels only.

INSTRUCTION/WARNING PLATE



DESCRIPTION/LOCATION
 Placard on exhaust stack storage door indicating proper stowage location.



Label indicating location of slave connection external 24VDC power point.



Label above lift ring (4 locations) indicating approved lift and tie down points.

INSTRUCTION/WARNING PLATE

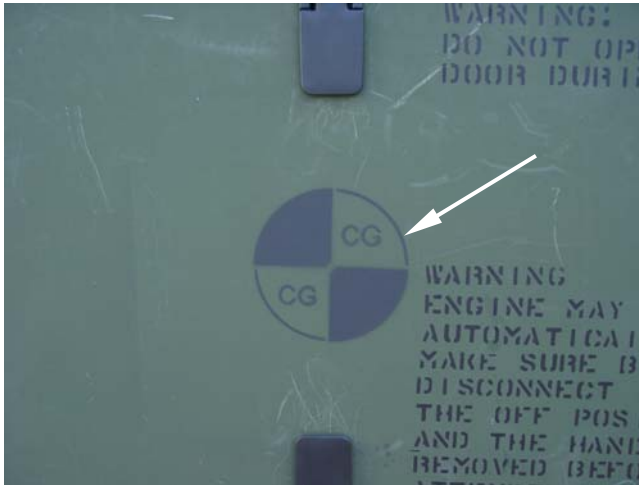

DESCRIPTION/LOCATION

Center of gravity marking on heater sides and top (3 locations) indicating the location of the center of gravity of the heater for safe lifting and loading.



Burner system schematic located on inside surface of burner access door.



Warning label on burner system ignitor pack alerting the operator to the existence of high voltage

INSTRUCTION/WARNING PLATE



DESCRIPTION/LOCATION

Label on burner access door indicating function.



Label on engine bay access door indicating function.



Label located above forklift pockets (4 locations) indicating location

INSTRUCTION/WARNING PLATE**DESCRIPTION/LOCATION**

Label on fuel panel access door indicating location.



Label on operator control box cover indicating location of operator control box.



Chemical Agent Resistant Coating (CARC) label on upper left corner of the engine access panel side of heater.

PREPARATION FOR MOVEMENT

Stowing the external fuel supply. If operating from an external fuel supply, the external fuel hose (1) must be stowed prior to movement.

Disengage the external fuel hose (1) by pushing back the outside collar of the external fuel connector (2) while pulling the external fuel hose.

Install the dust cap (3) on the male quick disconnect end (4) of the external fuel hose (1).

Starting at the heater, begin coiling the external fuel hose while holding the hose at a higher level than the bulk fuel supply. This will force any fuel in the external fuel hose back into the bulk supply container.

Once at the bulk fuel container connector, remove the 5/16 JIC female flair fitting (5) and install the dust plug (6).

Return the coiled external fuel hose to its stowage location (7) on the engine access door (8).



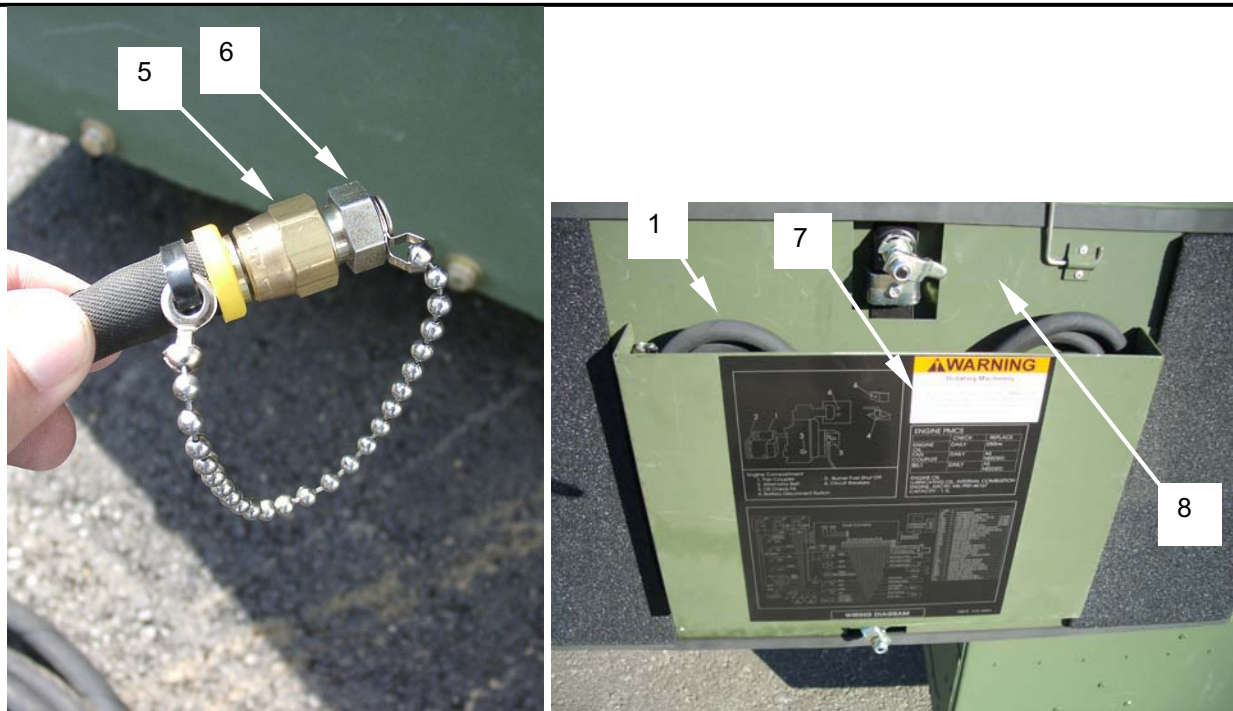

Stowing the operator control box. To prepare the LCFH for movement, stow the operator control box (1) by securing the CO detector. Close the cover (2) on the side of the operator control box (1) and secure by tightening the thumb screw (3).

Remove the operator control box from its hanging location and pass the panel and its connecting cable under the wall of the shelter.

Stow the operator control box in its docking location by aligning the upper retaining rail (4) on the panel with the mating rail on the cabinet. Secure the operator control box in place by engaging the turn-key latch (5) on the tab (6) at the lower right corner of the operator control box.

Wrap the operator control box cable (7) neatly around the operator control box handles (8). Tuck the last portion of the cable under the cable already secured to prevent the cable from unwinding.

Close the outer operator control box cover (9).

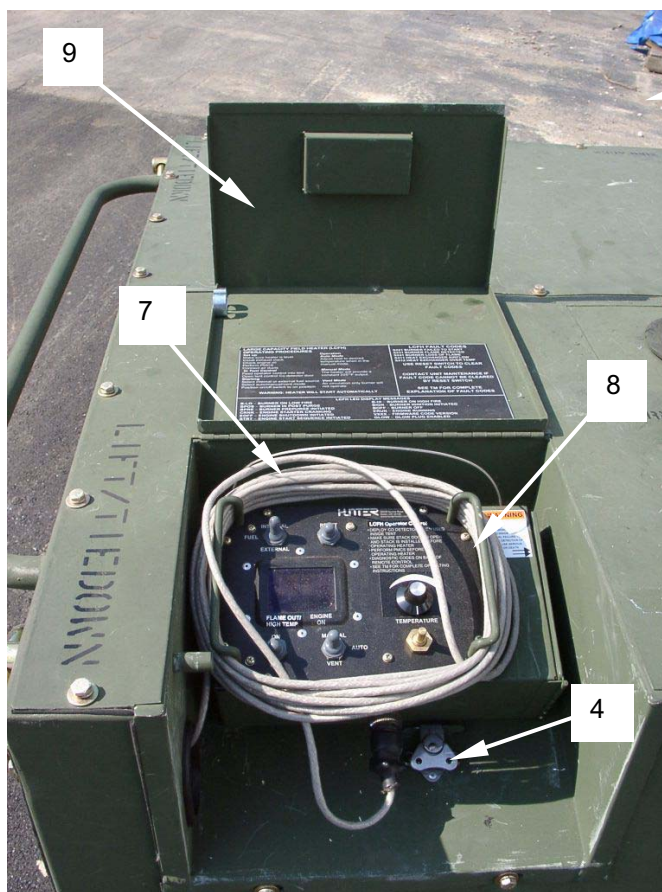
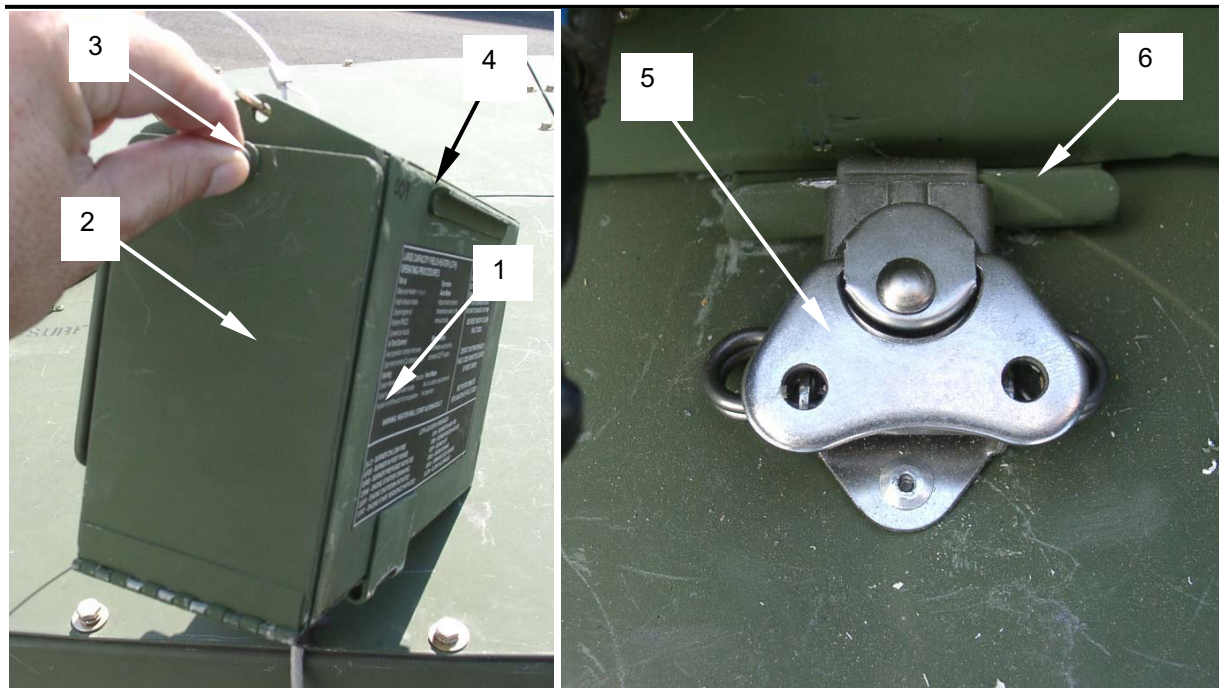

Stowing the flexible inlet and outlet ducts.**WARNING**

Gloves should be worn to protect against cuts and/or pinched fingers. Failure to do so could result in injury to hands.

To prepare the ducts for movement, untie the tent duct tunnel ties and remove the ducts from the inlet and outlet tent duct tunnels.

At the heater duct opening **(1)**, push in and rotate the duct end ring **(2)** counterclockwise to disengage the end ring **(2)**. Pull the duct **(3)** straight out from the heater.

Repeat for second duct.

To stow the flexible duct, place the opening **(4)** flat on the ground and compress the remaining duct **(5)** until the end is reached and the internal hook **(6)** can be engaged on the large internal hoop **(7)**.

Repeat for second flexible duct.

Stow both flexible ducts in a location that prevents them from being damaged.

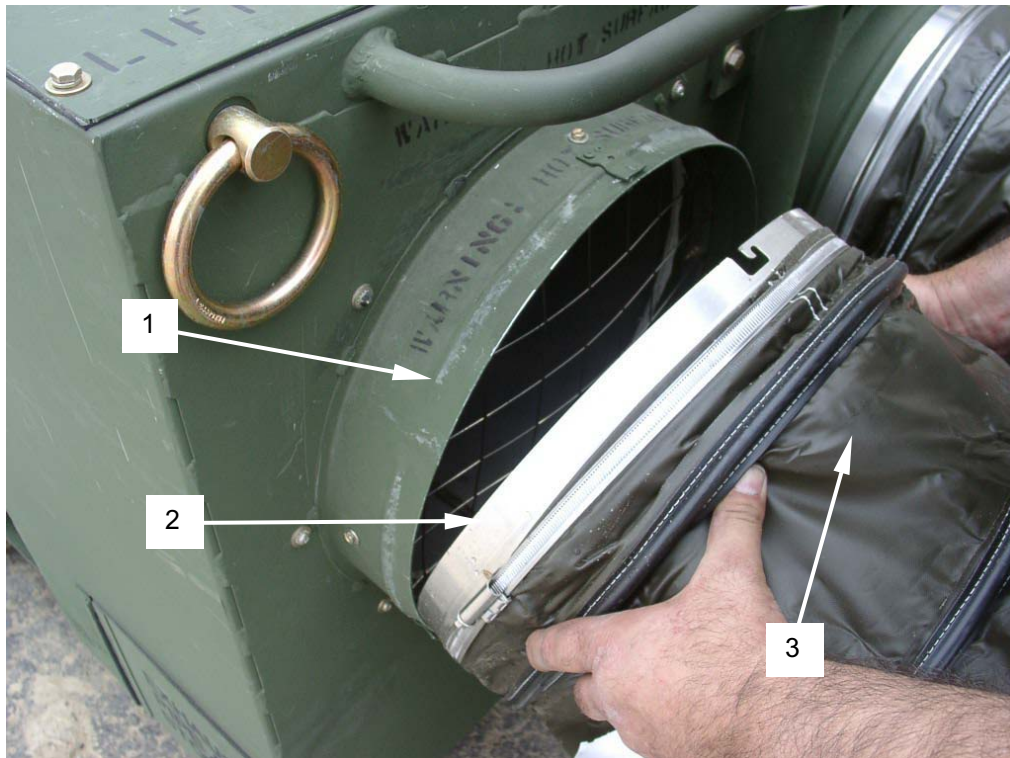

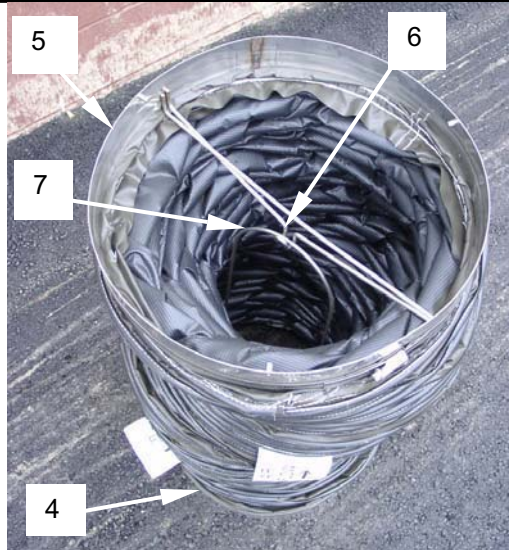

Stowing inlet and outlet duct covers. Stow the outlet duct cover (1) on the heated air outlet duct (2) by grasping the handle (3) and aligning the locking clips (4) with the rod that extends across the duct collar. Push down on the outlet duct cover (1) to engage the locking clips (4).

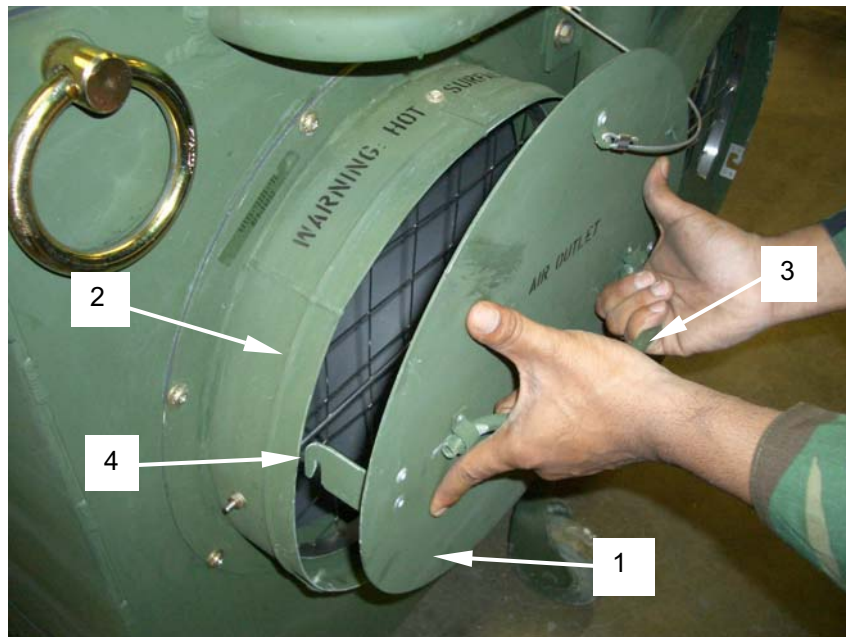

Stow the inlet duct cover (5) by grasping the handle (6) and aligning the locking clips (7) on the duct cover with the rod (8) that spans across the inlet duct collar (9). Press down on the inlet duct cover (5) to engage the locking clips (7) on the rod (8).

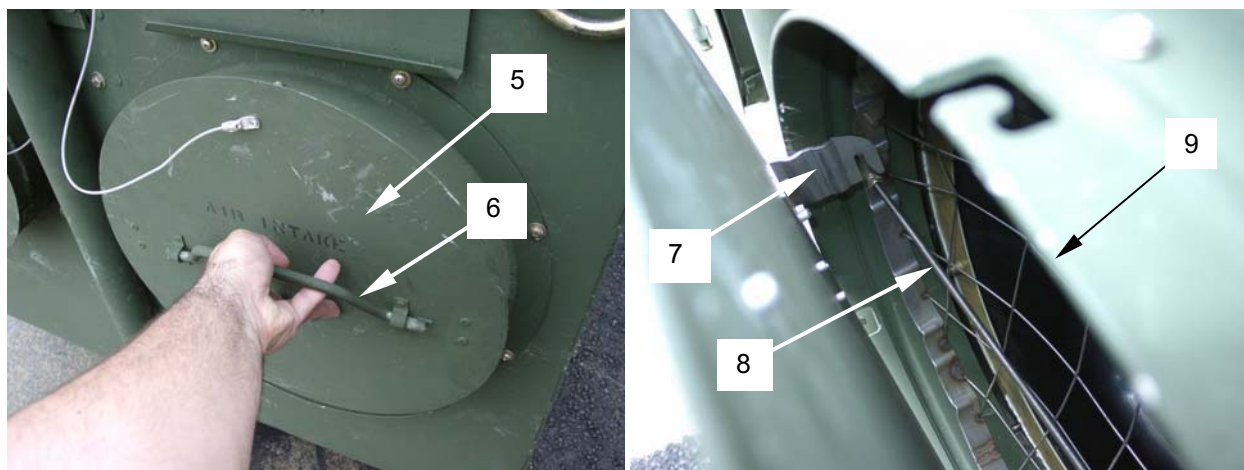

Stowing the exhaust stack. To stow the exhaust stack (1), remove from the exhaust stack port (2).

Open the exhaust stack stowage door (3) and insert the open end of the exhaust stack (1) first. Be sure that the exhaust stack is inserted fully into the retaining tube (4) inside the stowage area. Secure the stowage door (3).

Install the cap (5) on the exhaust stack port (2).

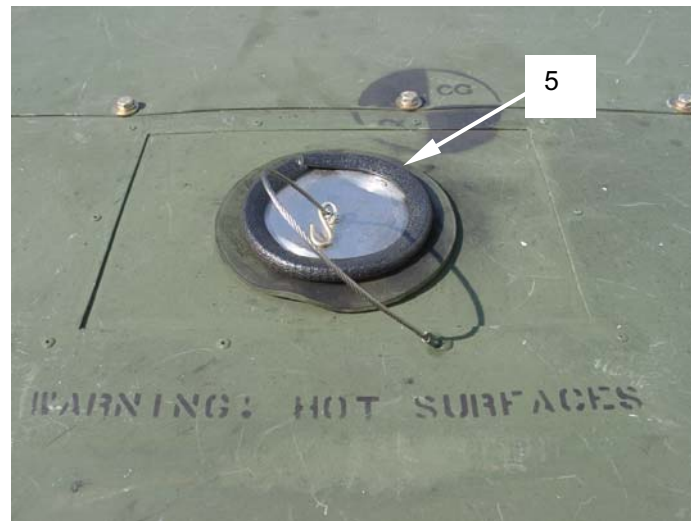
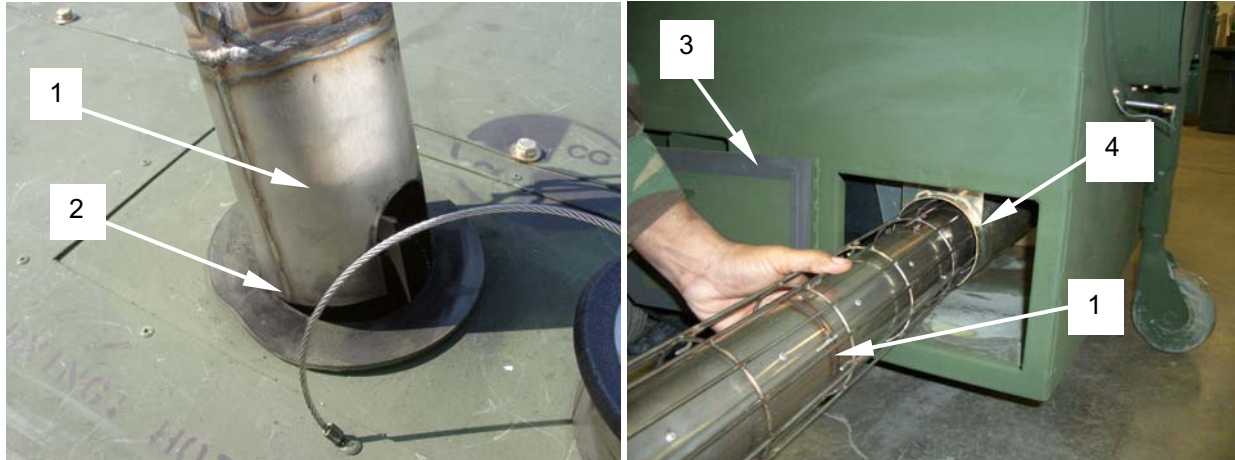

Stowing wheel chocks. If the heater is resting on its wheels and the wheel chocks are in place, they must be stowed prior to rolling the heater. Ensure that the heater will not move and remove the wheel chocks one wheel at a time.

Stow the wheel chocks **(1)** by placing them together so that their wider rear edges **(2)** are opposite one another. Wrap the tether **(3)** around the chocks to hold them together. Place the wheel chocks in their stowage area **(4)** on either side of the heater cabinet.

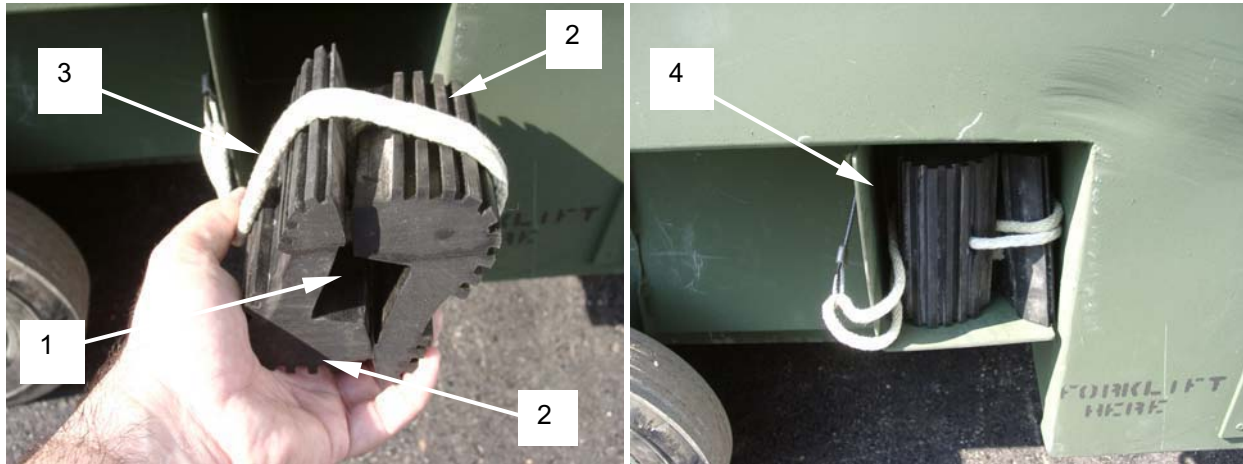

Lowering the side wheels. If the side wheels are in their raised position, they must be lowered and locked into position to permit local mobility.

Lower the front wheel **(1)** by rotating the wheel jack handle **(2)** clockwise until the front wheel **(1)** contacts the ground and begins to tilt the heater back on its snow skids. Continue until the front wheel is completely lowered.

Remove the locking pin **(3)** and remove wheel and axle assembly **(4)**.

Rotate the wheel and axle assembly **(4)** 90 degrees.

Reinstall wheel and axle assembly **(4)** and engage locking pin **(3)**.

Repeat for the opposite wheel.

Raise the front wheel **(1)** by rotating the wheel jack handle **(2)** counterclockwise until the top of the heater cabinet is parallel to the ground.

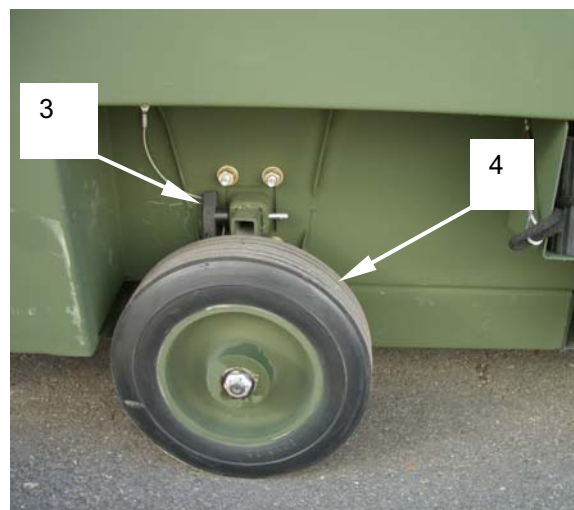
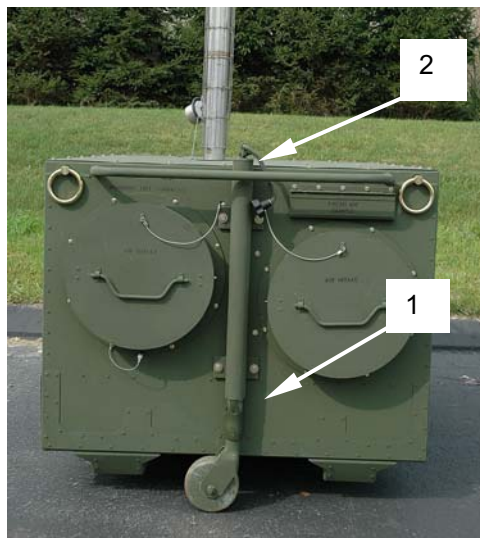

END OF WORK PACKAGE

**OPERATOR, FIELD AND SUSTAINMENT MAINTENANCE
LARGE CAPACITY FIELD HEATER (LCFH)
OPERATION UNDER UNUSUAL CONDITIONS**

OPERATION IN EXTREME SAND, DUST, AND/OR HIGH WINDS



WARNING

The heater has been designed to operate in dusty or sandy conditions. However, some forms of very fine dusts may be explosive (e.g., flour, chaff, coal, etc.). Before operation of the heater in dusty conditions, an attempt should be made to identify the dust type to insure that it is not explosive in nature.

If possible, the heater should be positioned to minimize the amount of dust, sand, or any other material in the area that could be pulled into the heater by the fans.

When operating in conditions of extreme sand or dust, ensure that the air supply and return ducts are securely attached to the heater and the ducts are securely connected to the shelter.

If high winds are expected, the ducts may require additional anchors or tiedowns to prevent high winds from shifting the equipment.

During refueling and at regular intervals between refueling, the heater and its ducts should be inspected for a buildup of dust or sand that would cover the heater or block the ducts or pipes.

During operation in extreme sand or dust, the fuel filter should be changed at twice the frequency noted in the Preventive Maintenance Checks and Service detailed in WP 0018 00.

Special care should be used during refueling to prevent sand or dust contamination of fuel, fuel supply, and fuel hoses.

OPERATION IN EXTREME RAIN OR HUMIDITY

When operating in conditions of extreme rain or humidity, it is recommended that the heated air outlet duct and air supply inlet duct be secured to the heater and the ducts securely connected to the tent.

Under no circumstances should the heater be positioned in standing water. Heater site should be graded slightly, if necessary, to insure that water runs away from heater and tent.

The inlet and outlet ducts and the heater itself might need to be raised higher off the ground to prevent water from entering the heater. The base contains three compartments in which the battery, combustion blower, and electronic controller are located. These compartments must not be submerged in standing water. If the heater is to be raised above ground level, make sure that water cannot run along ducts or along the operator control box cable and enter the tent.

If high winds accompany rain or humidity, additional anchors or tiedowns may be required to prevent winds from shifting the equipment.

During refueling and at regular intervals between refueling, the heater and ducts, and exhaust pipe should be inspected for a buildup of snow, dust, or sand that would cover the heater or block the ducts or pipes. Any buildup should be removed.

Special care should be used during refueling to prevent water, snow, sand, or dust contamination of fuel, fuel can, fuel hose, and fuel fittings.

OPERATION AT HIGH ALTITUDE

At altitudes above 6000 ft, adjustment to the burner fuel pump pressure may be necessary. Below 6000 feet elevation, the fuel pressure setting is 180 psi. At altitudes above 6000 feet, excessive smoke may be seen in the exhaust, and it may be necessary to reduce the fuel pressure to facilitate proper burner operation. Do not adjust the burner fuel pump pressure if excessive smoke is not being emitted in the exhaust.

Adjust burner fuel pump pressure for high altitude operation IAW WP 0033 00.

Be sure to reset the burner fuel pressure back to 180 psi when operating at altitudes below 6000 feet.

OPERATION IN A NBC ENVIRONMENT

WARNING

The heater is NOT DESIGNED TO BE OPERATED IN NBC ENVIRONMENTS.

Do not operate the LCFH in NBC environments. If possible cease operation of the LCFH prior to a NBC event and do the following:

- Disconnect and store under an impermeable cover the flexible inlet/outlet ducts, and install the covers on the heater inlet/outlet duct openings.
- Remove and stow the exhaust stack, and external fuel hose.
- Install the exhaust outlet cover, and close and latch all access doors.

External surfaces of the heater are CARC painted and can be decontaminated; however, if possible avoid contamination of the internal areas of the heater. If available, cover the heater with impermeable plastic tarp.

NBC DECONTAMINATION PROCEDURES**WARNING**

For "immediate decontamination procedures" use ONLY hot soapy water for decontaminating HOT surfaces of the heater and stack. Shut down and cool the heater for any additional decontamination procedures.

DO NOT SPRAY DS2 OR ANY OTHER COMBUSTIBLE DECONTAMINATION SOLUTIONS OR COMPOUNDS ON AN OPERATING HEATER OR STACK (NOTE: DS2 has a flashpoint of 160°F).

Perform immediate, operational or thorough decontamination procedures in accordance with FM 3-5 as the mission, resources and tactical situation permits.

END OF TASK

END OF WORK PACKAGE

**OPERATOR, FIELD AND SUSTAINMENT MAINTENANCE
LARGE CAPACITY FIELD HEATER (LCFH)
EMERGENCY ENGINE SHUTDOWN PROCEDURES**

INITIAL SETUP:Not Applicable

EMERGENCY SHUTDOWN PROCEDURES

In the event of battery failure or the electronic shut-off solenoid malfunctions, the diesel engine will continue to run until it runs out of fuel. If this happens, the engine will have to be shutdown manually using the following procedures.

WARNING



To avoid personal injury, remove all watches, rings, jewelry, and loose articles of clothing before performing any maintenance with the engine running and the engine bay access panel open. Hearing protection will be worn whenever the engine is running and the engine access panel is open.

1. Open the engine bay access panel.
2. Locate the engine stop lever **(1)** which is located on the outboard side of the engine just above the oil drain hose **(2)** and to the left of the dipstick **(3)**.

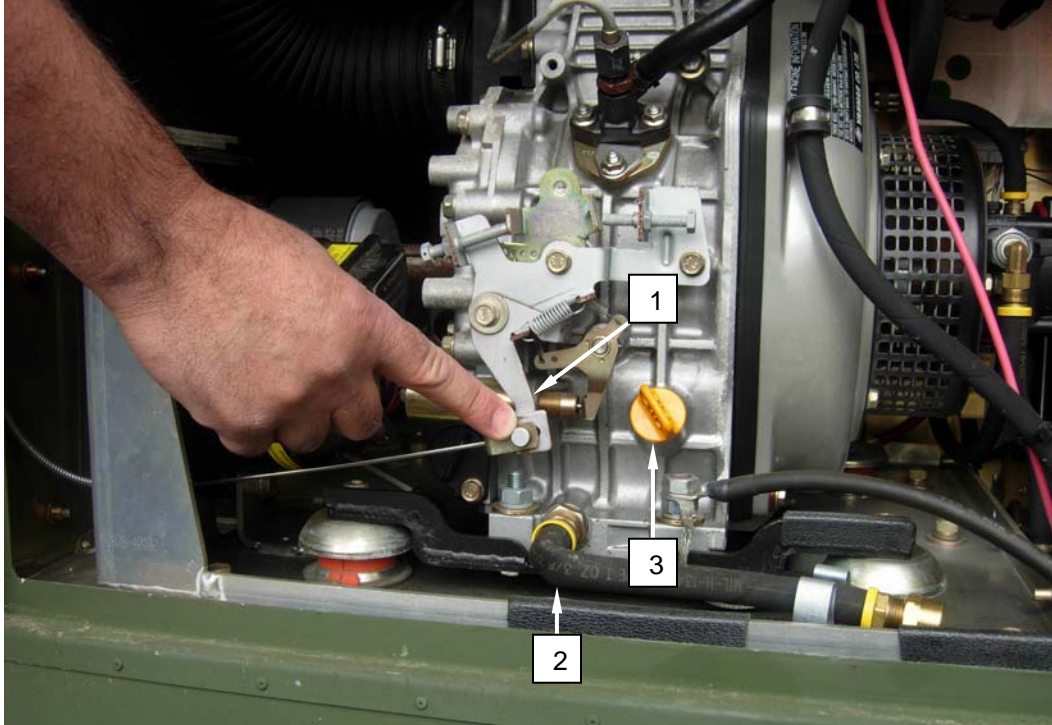

3. Pull the engine stop lever (4) to the left, in the direction indicated by the arrow (5), and hold until the engine stops.

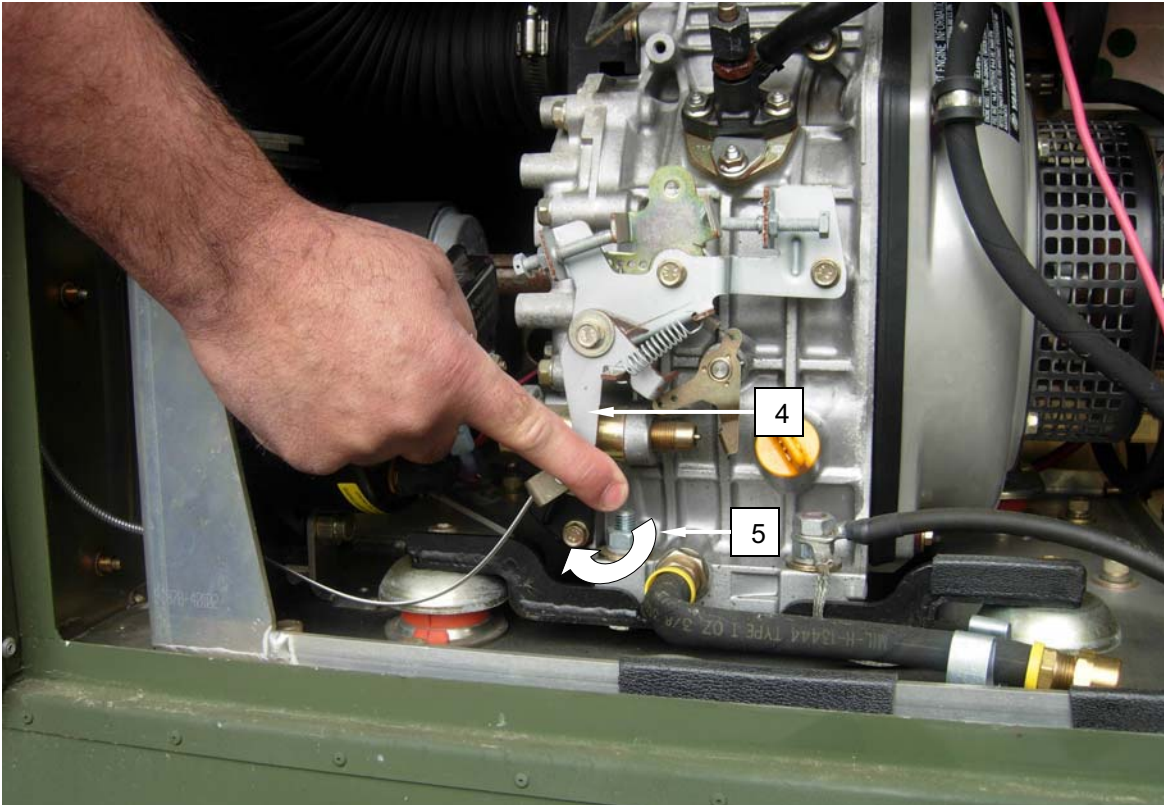

4. Upon shutdown, close all doors/panels and notify local Service or Field maintenance unit of the engine malfunction.

END OF TASK

END OF WORK PACKAGE

CHAPTER 3
OPERATOR TROUBLESHOOTING INSTRUCTIONS
LARGE CAPACITY FIELD HEATER (LCFH)

**OPERATOR MAINTENANCE
LARGE CAPACITY FIELD HEATER (LCFH)
MALFUNCTION SYMPTOM INDEX**

GENERAL

This chapter provides information to permit the operator to troubleshoot some problems that may occur during the operation of the LCFH.

MALFUNCTION SYMPTOM INDEX

The malfunction symptom index lists common malfunctions that may occur during the operation of the Large Capacity Field Heater. Find the malfunction to be eliminated and go to the indicated troubleshooting table in WP 0008 00. This index cannot list all malfunctions that may occur, all tests or inspections needed to find the fault, or all actions required to correct the fault. If the existing malfunction is not listed, or cannot be corrected through this troubleshooting index, notify unit maintenance.

In Table 2 below, a soft fault is defined as one in which the engine continues to operate but the burner is fault locked out; however, the heater can be reset to attempt another burner run cycle. If the burner is running when a soft fault occurs, the heater will proceed to the post purge cycle followed by fault lock out.

If a hard fault occurs before the burner starts or after the burner has normally cycled off (due to temperature regulation) then the heater will not proceed to post purge and the engine will shut down.

If a fault code is displayed with a troubleshooting step of N/A*, this fault cannot be resolved at the operator level and the LCFH should be referred to Unit Maintenance for additional troubleshooting action.

The last ten fault codes that have been displayed on the operator control box can be displayed in reverse order by toggling the switch labeled RESET on the operator control box front panel. This is useful in the case of a fault code being displayed too quickly to note or if maintenance wishes to view the last ten fault codes.

Table 1. LCFH Fault Code Series Key.

Series	System Affected
100 series	Electrical
200 series	Burner
300 series	Carbon Monoxide (CO) sensor
400 series	Control panel
500 series	Engine
600 series	Solenoids
801	Software

Malfunction

Troubleshooting Step

No power when power switch is turned on	1
Heater will not start after 3 attempts	2
Heater starts but sputters or runs erratically	3
Heater runs then shuts down unexpectedly with no error code displayed on control panel.....	4
A fuel leak is observed in the heater	22
The operator control panel is off, but the engine continues to run	23

Heater starts, continues to run but displays one of the following fault codes shown in Table 2:

Table 2. LCFH Operator Level Soft Fault Codes.

Fault Code	Description	Troubleshooting Step
Soft Faults		
S221	Burner failed to start.....	7
S231	Flame detected in post-purge	8
S241	Flame not detected at flame sensor.....	9
S411	Heat exchanger airflow not detected	6
S412	Heat exchanger over temperature	5

Heater may or may not start, shuts down and displays following fault codes shown in Table 3:

Table 3. LCFH Operator Level Hard Fault Codes.

Fault Code	Description	Troubleshooting Step
Hard Faults		
H111	Alternator excitation open circuit	*
H112	Alternator excitation short circuit	*
H121	Alternator Tachometer loss of signal during engine run.....	15
H122	Alternator Tachometer not detected during Engine Crank.....	16
H123	Alternator tachometer signal present after engine shutdown.....	*
H124	Alternator tachometer signal present before engine start	*
H130	Battery Voltage Low/High (checked during engine operation 19.5V to 32V)	10
H131	Battery low voltage (checked during engine start 15V minimum)	11
H211	Burner Combustion Fan Low Current (2.5 amps)	12
H212	Burner combustion fan over current condition detected (checked after engine start).....	*
H232	Burner Flame detected during burner pre-purge.....	14
H251	Spark ignition transformer relay open circuit T1	*
H252	Spark ignition transformer relay short circuit T1	*
H311	Carbon monoxide detected at operator control panel	20
H312	Carbon monoxide detected in inlet air	21
H321	Carbon monoxide (CO) inlet air sensor open circuit (driver side)	*
H322	Carbon monoxide (CO) inlet air sensor short circuit (driver side)	*
H331	Carbon monoxide (CO) operator control panel Sensor Open Circuit (driver side) ..	*
H332	Carbon monoxide (CO) operator control panel Sensor Short Circuit (driver side) ..	*
H421	Operator Control Panel cable connection RS485 Response Timeout.....	18
H431	Outlet Temperature Sensor (RTD1) open circuit	*
H432	Outlet Temperature Sensor (RTD1) short circuit	*
H511	Engine Fail to start after 3 tries	19

Fault Code	Description	Troubleshooting Step
H521	Engine fuel pump (P1) open circuit	*
H522	Engine fuel pump (P1) short circuit	*
H531	Engine oil pressure before engine start.....	*
H532	Engine Oil pressure low during engine run	13
H541	Engine pre-heat relay driver K1 open circuit	*
H542	Engine pre-heat relay driver K1 short circuit	*
H551	Engine starter relay driver open circuit.....	*
H552	Engine starter relay driver short circuit.....	*
H561	Engine Throttle Stop Solenoid Relay driver K2 Open Circuit.....	17
H562	Engine throttle stop solenoid relay driver K2 short circuit	*
H611	Fuel solenoid valve FS1 open circuit (burner on/off).....	*
H612	Fuel solenoid valve FS1 short circuit (burner on/off).....	*
H621	Fuel solenoid valve FS2 open circuit (burner high/low)	*
H622	Fuel solenoid valve FS2 short circuit (Burner high/low)	*
H631	Fuel solenoid valve FS3 open circuit (internal/external fuel).....	*
H632	Fuel solenoid valve FS3 short circuit (internal/external fuel).....	*
H801	Watchdog (COP) Timeout (loss of software control for >1 sec).....	*

* Cannot troubleshoot malfunction at operator level. Refer heater to Unit level maintenance.

END OF WORK PACKAGE

**OPERATOR MAINTENANCE
LARGE CAPACITY FIELD HEATER (LCFH)
TROUBLESHOOTING PROCEDURES**

INITIAL SETUP:

Tools

None required

Personnel Required

MOS non-specific

Materials/Parts

None required

Equipment Condition

Place power switch to OFF position after fault code is displayed.

Heater shutdown and post-purge complete.

Heater cool.

Table 1. Troubleshooting Procedure for Large Capacity Field Heater (LCFH).

MALFUNCTION	TEST OR INSPECTION	CORRECTIVE ACTION
1. No power when power switch is turned on.	<p>Step 1. Turn power switch OFF. Open side access door and verify that both batteries are installed and that the cables are attached securely.</p> <p>Step 2. Turn power switch OFF. Verify that main battery switch is in the ON position.</p> <p>Step 3. Verify that batteries are fully charged.</p>	<p>Step 1. If batteries are not installed or appear to be damaged in any way or if the battery cables are not securely installed, notify unit maintenance.</p> <p>Step 2. Place battery switch in ON position.</p> <p>Step 3. Attach NATO slave cable, start heater, and recharge batteries until fully charged.</p> <p>Step 4. If further corrective action is required, notify Unit Maintenance.</p>
2. Heater will not start after 3 attempts	<p>Step 1. The heater will attempt to restart 3 times on its own. Determine if the heater has completed a restart cycle attempt.</p>	<p>Step 1. Attempt up to three restart cycles in 60 minutes.</p> <p>Step 2. If further corrective action is required, notify Unit Maintenance.</p>
3. Heater starts but sputters or runs erratically	<p>Step 1. Check the fuel gauge and verify that there is sufficient fuel.</p> <p>Step 2. Verify that the fuel being supplied is of an approved type and that it is clean and not contaminated.</p> <p>Step 3. If heater has been switched from internal to external fuel mode, verify that heater has operated long enough to expel all air in the external fuel hose. This may only be a problem if fuel level in internal tank is very low when switched to external.</p>	<p>Step 1. Turn power switch OFF. Fill the fuel tank with an approved fuel and/or replenish the external fuel supply with adequate supply of approved fuel. Attempt restart.</p> <p>Step 2. Fill internal tank or bulk fuel supply with that fuel is clean and not contaminated.</p> <p>Step 3. Allow heater to operate long enough to expel all air that may be present in the external fuel hose.</p> <p>Step 4. If problem persists, notify unit maintenance.</p>

Table 1. Troubleshooting Procedure for Large Capacity Field Heater (LCFH).

MALFUNCTION	TEST OR INSPECTION	CORRECTIVE ACTION
<p>4. Heater runs then shuts down unexpectedly with no fault code displayed on control panel</p>	<p>Step 1. Verify that there is sufficient fuel in the fuel tank or that the external fuel supply has sufficient fuel</p>	<p>Step 1. Turn power switch OFF. Fill the fuel tank with an approved fuel and/or replenish the external fuel supply with adequate supply of approved fuel. Attempt restart.</p> <p>Step 2. If heater runs then shuts down unexpectedly again, notify unit maintenance for further corrective action.</p>
<p>5. Heater starts, displays fault code: S412 but continues to run</p>	<p>Step 1. This fault code indicates that the heat exchanger over-temperature switch SW4 has been activated. Turn power switch OFF. Check and ensure that there is no blockage at air inlet or outlet duct.</p>	<p>Step 1. Clear any blockage at air inlet or air outlet duct.</p> <p>Step 2. Flip RESET switch, attempt restart. If problem has not been corrected, notify unit maintenance.</p>
<p>6. Heater starts, displays fault code: S411 but continues to run</p>	<p>Step 1. This fault code indicates that the heat exchanger airflow has been blocked or restricted. Turn power switch OFF. Check for blockage on air inlet or air outlet duct.</p> <p>Step 2. Check for loose inlet fan. A visible wobble or rubbing on the fan housing would be evidence that inlet fan is loose. If this is suspected, notify unit maintenance.</p> <p>Step 3. Check air sensor hose from bulkhead to main control box and ensure that it is connected and not kinked, cut, or damaged in any way.</p>	<p>Step 1. Clear any blockage on air inlet or air outlet duct. Flip RESET switch, attempt restart.</p> <p>Step 2. If a loose inlet fan is suspected, notify unit maintenance.</p> <p>Step 3. Connect air sensor hose from bulkhead to main control box if disconnected. Ensure that hose is not kinked, cut, or damaged in any way. Flip RESET switch, attempt restart.</p> <p>Step 4. If problem has not been corrected, notify unit maintenance.</p>
<p>7. Heater starts, displays fault code: S221 but burner fails to start</p>	<p>Step 1. This fault code indicates that burner failed to start after 3 tries. The diesel engine and other systems may operate but the burner failed to start. Turn power switch OFF. Check to ensure that there is adequate fuel in the fuel tank or in the bulk fuel supply.</p> <p>Step 2. Open the burner access door and ensure that the flame sensor wire harness connector is connected securely (see WP 0053 00 for location).</p>	<p>Step 1. Fill heater with adequate fuel in the internal fuel tank or in the bulk fuel supply. Flip RESET switch, attempt restart.</p> <p>Step 2. Connect flame sensor wire harness connector securely (see WP 0053 00 for location). Flip RESET switch, attempt restart.</p> <p>Step 3. If problem has not been corrected, notify unit maintenance.</p>

Table 1. Troubleshooting Procedure for Large Capacity Field Heater (LCFH).

MALFUNCTION	TEST OR INSPECTION	CORRECTIVE ACTION
<p>8. Heater starts, runs properly but displays fault code: S231 when the system is in post-purge mode</p>	<p>Step 1. This fault code indicates that there was a burner flame detected during burner post-purge. Turn power switch OFF. Check to see if this may be caused by excess fuel in the burner during system post-purge or by excess carbon in the burner.</p>	<p>Step 1. View burner through sight glass and determine if flame is still present after burner is shutdown. If not, Flip RESET switch, attempt restart. If flame is visible, notify unit maintenance.</p>
<p>9. Heater starts, runs for a time, and then displays fault code: S241</p>	<p>Step 1. This fault code indicates that the burner had a loss of flame while running. Turn power switch OFF. Check to ensure that there is adequate fuel in the fuel tank or in the bulk fuel supply.</p> <p>Step 2. Check to see if heater fuel mode switch is in external fuel mode when heater is operating from internal fuel supply.</p> <p>Step 2. Open the burner access door and ensure that the flame sensor wire harness connector is connected securely (see WP 0053 00 for location).</p>	<p>Step 1. Fill heater with adequate fuel in the internal fuel tank or in the bulk fuel supply. Flip RESET switch, attempt restart.</p> <p>Step 2. Place fuel mode switch in INTERNAL mode if operating from the internal fuel supply. Place in EXTERNAL mode if operating from external fuel supply.</p> <p>Step 3. Connect flame sensor wire harness connector securely (see WP 0053 00 for location). Flip RESET switch, attempt restart.</p> <p>Step 4. If problem has not been corrected, notify unit maintenance.</p>
<p>10. Heater starts, shuts down, and displays fault code: H130</p>	<p>Step 1. This fault code indicates that the system is experiencing a battery low or high condition. Turn power switch OFF. Open engine bay access door and inspect the wires going to the alternator and ensure that they are all connected properly and that they are not cut or damaged in any way.</p> <p>Step 2. Ensure that the alternator belt is not loose.</p> <p>Step 3. Ensure that all of the battery cable connections are secure and that the cables are not damaged in any way.</p>	<p>Step 1. Secure any loose or disconnected wires going to the alternator. Notify unit maintenance if any wires are cut or damaged in any way.</p> <p>Step 2. If alternator belt is loose, notify unit maintenance.</p> <p>Step 3. If any battery cable connections are loose or damaged, notify unit maintenance.</p> <p>Step 4. If problem has not been corrected, notify unit maintenance.</p>
<p>11. Heater starts, shuts down, and displays fault code: H131</p>	<p>Step 1. This fault code indicates that the system is experiencing a battery low voltage condition (battery must have 15V minimum). Check outdoor temperature. If temperature is -40 degrees F or lower, use the slave connector to provide supplemental source of 24VDC power to heater.</p>	<p>Step 1. Connect slave connector to supplemental source of 24VDC power to heater.</p>

Table 1. Troubleshooting Procedure for Large Capacity Field Heater (LCFH).

MALFUNCTION	TEST OR INSPECTION	CORRECTIVE ACTION
	<p>Step 2. Turn power switch OFF. Open engine bay access door and inspect the wires going to the alternator and ensure that they are all connected properly and that they are not cut or damaged in any way.</p> <p>Step 3. Ensure that the alternator belt is not loose.</p> <p>Step 4. Ensure that all of the battery cable connections are secure and that the cables are not damaged in any way.</p>	<p>Step 2. Secure any loose or disconnected alternator wires. If any alternator wires are cut or damaged, notify unit maintenance.</p> <p>Step 3. If alternator belt is loose, notify unit maintenance.</p> <p>Step 4. If battery connections are loose or damaged in any way, notify unit maintenance.</p> <p>Step 5. If problem has not been corrected, notify unit maintenance.</p>
<p>12. Heater starts, shuts down, and displays fault code: H211</p>	<p>Step 1. This fault code indicates that there is a low current condition at the burner combustion fan. Turn power switch OFF. Open burner access door and check for broken combustion fan wiring harness or connector. Ensure that wire is not broken and that both halves of connector are securely mated.</p>	<p>Step 1. Securely connect both halves of connector. If wiring or connector is damaged, notify unit maintenance.</p> <p>Step 2. If problem has not been corrected, notify unit maintenance.</p>
<p>13. Heater starts, shuts down, and displays fault code: H532</p>	<p>Step 1. This fault code indicates that the oil pressure of the diesel engine is low. Turn power switch OFF. Check oil level of diesel engine and ensure that level is adequate.</p>	<p>Step 1. Check to ensure that heater has adequate fuel.</p> <p>Step 2. Fill diesel engine with oil to FULL level IAW WP 0010 00.</p> <p>Step 3. If problem has not been corrected, notify unit maintenance.</p>
<p>14. Heater starts, shuts down, and displays fault code: H232</p>	<p>Step 1. This fault code indicates that a flame was detected during burner pre-purge. Turn power switch OFF. Open burner access door and ensure that flame sensor is securely installed in flame sensor tube.</p>	<p>Step 1. Secure a loose flame sensor by pressing firmly into flame sensor tube. If retaining clamp is loose, notify unit maintenance.</p> <p>Step 2. If problem has not been corrected, notify unit maintenance.</p>
<p>15. Heater starts, shuts down, and displays fault code: H121</p>	<p>Step 1. This fault code indicates a loss of signal from the alternator tachometer occurred during operation. Turn power switch OFF. Inspect engine bay, fuel access, and burner areas for any signs of fuel loss.</p> <p>Step 2. Inspect wiring on alternator and ensure that all wires are secured and are undamaged.</p> <p>Step 3. Ensure that the alternator belt is not broken or damaged.</p>	<p>Step 1. Check to ensure that heater has adequate fuel. If any fuel loss is observed, notify unit maintenance.</p> <p>Step 2. Secure any loose connectors on alternator. If any wires are cut or damaged, notify unit maintenance.</p> <p>Step 3. If alternator belt is loose or if broken notify unit maintenance.</p>

Table 1. Troubleshooting Procedure for Large Capacity Field Heater (LCFH).

MALFUNCTION	TEST OR INSPECTION	CORRECTIVE ACTION
<p>16. Heater starts, shuts down, and displays fault code: H122</p>	<p>Step 4. Ensure that flexible coupling is not broken or damaged.</p> <p>Step 1. This fault code indicates that the alternator tachometer was not detected during engine crank. During heater startup, determine if diesel engine starter is turning. If unsure, and problem persists, contact unit maintenance.</p> <p>Step 2. Turn power switch OFF. Inspect wiring on alternator and ensure that all wires are secured and are undamaged.</p> <p>Step 3. Ensure that the alternator belt is not broken or damaged.</p> <p>Step 4. Ensure that flexible coupling is not broken or damaged.</p>	<p>Step 4. If flexible coupling assembly is loose or damaged notify unit maintenance.</p> <p>Step 5. If problem has not been corrected, notify unit maintenance.</p> <p>Step 1. If diesel engine starter is not turning during heater startup or if unsure and problem persists, contact unit maintenance.</p> <p>Step 2. Secure any loose wires on alternator. If wires are cut or damaged, notify unit maintenance.</p> <p>Step 3. If alternator belt is damaged or broken, notify unit maintenance.</p> <p>Step 4. If flexible coupling is broken or damaged, notify unit maintenance.</p> <p>Step 5. If problem has not been corrected, notify unit maintenance.</p>
<p>17. Heater starts, shuts down, and displays fault code: H561</p>	<p>Step 1. This fault code indicates that there is an open circuit detected at the engine throttle stop solenoid relay driver K2. Turn power switch OFF. Open engine bay access door and inspect relay box assembly to ensure that wiring harness is not damaged and that the connector is engaged securely.</p>	<p>Step 1. Secure wiring harness connector on relay box assembly as required. If any wires are cut or damaged, notify unit maintenance.</p> <p>Step 2. If problem has not been corrected, notify unit maintenance.</p>
<p>18. Heater starts, shuts down, and displays fault code: H421</p>	<p>Step 1. This fault code indicates that the system is not receiving a proper response from the operator control box. Turn power switch OFF. Ensure that the connection between the operator control box and the operator control box cable is secure. Ensure that the connector is not damaged in any way and that the cable is not cut or damaged.</p> <p>Step 2. Turn power switch OFF. Ensure that the connection between the main control box and the operator control box cable is secure. Ensure that the connector is not damaged in any way and that the cable is not cut or damaged.</p>	<p>Step 1. Secure connection between the operator control box and the operator control box cable. Notify unit maintenance if connector is damaged in any way and/or the cable is cut or damaged.</p> <p>Step 2. Secure the connection between the main control box and the operator control box cable. Notify unit maintenance if connector is damaged in any way and/or the cable is cut or damaged.</p>

Table 1. Troubleshooting Procedure for Large Capacity Field Heater (LCFH).

MALFUNCTION	TEST OR INSPECTION	CORRECTIVE ACTION
<p>19. Heater starts, shuts down, and displays fault code: H511</p>	<p>Step 1. This fault code indicates that the engine failed to start after 3 tries. Check to ensure that there is adequate fuel in the fuel tank or in the bulk fuel supply.</p> <p>Step 2. Turn power switch OFF. Open engine bay access door and inspect location of engine throttle. Ensure that the engine throttle cable is not stuck in OFF position.</p>	<p>Step 3. If problem has not been corrected, notify unit maintenance.</p> <p>Step 1. Fill internal fuel tank or ensure there is adequate fuel in the bulk fuel supply.</p> <p>Step 2. If engine throttle shutdown cable is stuck or damaged in any way, notify unit maintenance.</p> <p>Step 3. If problem has not been corrected, notify unit maintenance.</p>
<p>20. Heater starts, shuts down, and displays fault code: H311</p>	<p>Step 1. This fault code indicates that the LCFH has detected carbon monoxide at the operator control panel. Evacuate any personnel that may be in the shelter and look for signs of carbon monoxide poisoning. Check the flexible air inlet duct and ensure that it does not have any rips, tears, or other damage that would allow combustion exhaust to enter the inlet air flow.</p> <p>Step 2. Check and ensure that the flexible inlet air duct is securely attached to the air inlet duct adapter on the LCFH.</p> <p>Step 3. Ensure that the shelter opening is not downwind of the LCFH in such a way as to allow combustion exhaust to enter the shelter.</p> <p>Step 4. Determine if there are any other sources of carbon monoxide (vehicles, generators, etc.) that may be running nearby. Determine if the combustion exhaust from those sources may be getting into the LCFH airflow.</p>	<p>Step 1. Repair any tears in the flexible air inlet duct with duct tape. Replace flexible air duct if damage cannot be completely repaired with duct tape.</p> <p>Step 2. Attach flexible air inlet duct to air inlet duct adapter lock in place securely.</p> <p>Step 3. Move LCFH so that combustion exhaust does not enter shelter during LCFH operation.</p> <p>Step 4. Move sources of carbon monoxide a safe distance away from the shelter and the LCFH.</p> <p>Step 5. Restart LCFH. If fault reoccurs, stop use of LCFH and notify Unit Maintenance.</p>
<p>21. Heater starts, shuts down, and displays fault code: H312</p>	<p>Step 1. This fault code indicates that the LCFH has detected carbon monoxide at the cabinet mounted carbon monoxide detector. Evacuate any personnel that may be in the shelter and look for signs of carbon monoxide poisoning. Check the flexible air inlet duct and ensure that it does not have any rips, tears, or other damage that would allow combustion exhaust to enter the inlet air flow.</p> <p>Step 2. Check and ensure that the</p>	<p>Step 1. Repair any tears in the flexible air inlet duct with duct tape. Replace flexible air duct if damage cannot be completely repaired with duct tape.</p> <p>Step 2. Re-attach flexible air inlet</p>

Table 1. Troubleshooting Procedure for Large Capacity Field Heater (LCFH).

MALFUNCTION	TEST OR INSPECTION	CORRECTIVE ACTION
	<p>flexible inlet air duct is securely attached to the air inlet duct adapter on the LCFH.</p> <p>Step 3. Ensure that the shelter opening is not downwind of the LCFH in such a way as to allow combustion exhaust to enter the shelter.</p> <p>Step 4. Determine if there are any other sources of carbon monoxide (vehicles, generators, etc.) that may be running nearby. Determine if the combustion exhaust from those sources may be getting into the LCFH airflow.</p>	<p>duct to air inlet duct adapter lock in place securely.</p> <p>Step 3. Move LCFH so that combustion exhaust does not enter shelter during LCFH operation.</p> <p>Step 4. Restart LCFH. If fault reoccurs, stop use of LCFH and notify Unit Maintenance.</p> <p>Step 5. Restart LCFH. If fault reoccurs, stop use of LCFH and notify Unit Maintenance.</p>
<p>22. A fuel leak is observed in the heater.</p>	<p>Step 1. Determine the area where the leak is originating. In all likelihood, this will be in the area of the fuel panel assembly, the burner valve assembly, or the fuel tank assembly.</p>	<p>Step 1. Shut down heater. Inspect each area to determine the specific fitting or hose that is leaking. Take note of the fitting or hose that is leaking and notify unit maintenance of the location determined.</p>
<p>23. The operator control panel is off and the LED screen is blank, but the engine continues to run.</p>	<p>The diesel engine does not require electrical power to operate, though electrical power is needed to shut it down.</p>	<p>Perform emergency engine shutdown procedure outlined in WP 0006 01.</p>

CHAPTER 4
OPERATOR MAINTENANCE INSTRUCTIONS
LARGE CAPACITY FIELD HEATER (LCFH)

**OPERATOR AND FIELD MAINTENANCE
LARGE CAPACITY SPACE HEATER (LCFH)
PREVENTIVE MAINTENANCE CHECKS AND SERVICES INTRODUCTION**

INTRODUCTION

Preventive Maintenance Checks and Services (PMCS) are performed to keep the Large Capacity Field Heater in good operating condition and ready for its primary mission. The checks are used to find, correct, and report problems. PMCS is performed every day the Large Capacity Field Heater is in operation, and is done according to the PMCS table provided. Pay attention to **WARNING**, **CAUTION**, and **NOTE** statements. A **WARNING** indicates that someone could be hurt or killed. A **CAUTION** indicates that equipment could be damaged. A **NOTE** may make your maintenance or repair task easier.

Be sure to perform scheduled PMCS. Always perform PMCS in the same order so it becomes habit. With practice, you will quickly recognize problems with the equipment.

Use DA Form 2404, Equipment Inspection and Maintenance Worksheet, to record any discovered faults. Do not record faults that you fix!

PMCS PROCEDURES

Table 1 lists inspections and care required to keep your equipment in good operating condition. It is arranged so that you can perform before operation checks as you walk around the equipment.

Explanation of Table 1 Columns**Item Number**

Indicates the reference number. When completing DA Form 2404, Equipment Inspection and Maintenance Worksheet, include the item number for the item to check/service indicating a fault. Item numbers appear in the order you must perform the checks/services listed.

Interval

Indicates when you must perform the procedure in the procedure column.

- before** - perform before equipment operation
- during** - perform during equipment operation
- after** - perform after equipment has been operated
- weekly** - perform every week
- monthly** - perform each month
- hours** - perform at the noted hourly interval

Item to Check/Service

Indicates the item to be checked or serviced.

Procedure

Indicates the procedure you must perform on the item listed in Item to Check/Service column. You must perform the procedure at the time specified in the Interval column.

Not Fully Mission Capable If:

Indicates faults which will prevent your equipment from performing its primary mission. If you perform procedures listed in Procedure column which show faults listed in this column, do not operate the equipment. Follow standard procedures for maintaining the equipment or reporting equipment failure. If you are not authorized to perform a task, notify unit maintenance.

Other special entries

Observe all special information and notes that appear in Table 1.

When a check/service procedure is required for both weekly and before intervals, it is not necessary to perform the procedure twice if the equipment is operated during the weekly period.

COMMON CHECKS AND CLEANING**Cleaning**

Always keep the equipment clean. Remove dirt, sand, and debris from all circuit breakers and hose connections.

Bolts, nuts, and screws

Check them for obvious looseness, missing, bent, or broken condition on equipment. If you find a bolt, nut, or screw you think is loose, tighten it or report it to your supervisor.

Hoses

Look for wear, damage, and leaks. Ensure clamps are tight. Wet spots show leaks, but a stain around a fitting or connector can also mean a leak. If a leak comes from a loose fitting or coupling, tighten it. If something is broken or worn out, report it to your supervisor.

LEAKAGE DEFINITION FOR PERFORMING PMCS

It is necessary for you to know how fluid leakage affects the status of the equipment. The following are the types/classes of leakage an operator needs to know to be able to determine the status of the water system. Learn these leakage definitions and remember - when in doubt, notify your supervisor.

CAUTION

Equipment operation is allowable with minor leakages (Class I or II). Of course, consideration must be given to fluid capacity in the system, when in doubt, notify your supervisor.

When operating with Class I or II leaks, continue to check fluid levels as required in your PMCS.

Class III leaks should be reported immediately to your supervisor.

Class I - Seepage of fluid (as indicated by wetness or discoloration) not great enough to form drops.

Class II - Leakage of fluid great enough to form drops but not enough to cause drops to drip from item being checked/inspected.

Class III - Leakage of fluid great enough to form drops that fall from items being checked/inspected.

**OPERATOR AND/OR FIELD MAINTENANCE
LARGE CAPACITY FIELD HEATER (LCFH)
OPERATOR PREVENTIVE MAINTENANCE CHECKS AND SERVICES**



WARNING

Hearing protection should be worn when performing any troubleshooting or maintenance function requiring that the heater be operating with any of the access panels open. Failure to wear ear protection could result in hearing loss or damage.

Table 1. Operator Preventive Maintenance Checks and Services.

ITEM NO.	INTERVAL	LOCATION ITEM TO CHECK/SERVICE	PROCEDURE	NOT FULLY MISSION CAPABLE IF:
1	Before	Air Supply and Return Ducts	<p>Check the fresh air inlet (1) and heated air outlet (2) ducts for holes and tears in the fabric. Repair damaged ducts if possible, replace duct if damage cannot be repaired.</p> <p>Check outside surface of duct for any dirt or debris. Clean dirt and debris from exterior of duct with a clean dry rag.</p> <p>Check for and remove any obstructions inside of ducts.</p> <p>Inspect mounting rings (3) on ends of ducts for any type of damage that would prevent the duct from being properly mounted to the heater inlet and outlet ducts.</p>	<p>There are holes, tears, or other damage that cannot be repaired and that would permit air to enter or escape through the side walls of the duct.</p> <p>Excessive dirt or debris is present on duct.</p> <p>Obstructions within the duct that cannot be cleared.</p> <p>Mounting rings damaged so as to prevent proper mounting to heater ducts.</p>
	During		Periodically check the fresh air inlet duct area (1) and screen for dirt and debris. If excessive dirt or debris is evident, temporarily shut down the heater and clean/remove the dirt and debris.	Excessive dirt or debris is present in the return duct and inlet screen area that restricts airflow.
	After		After shutting down the heater, if excessive dirt or debris is evident on the fresh air inlet duct area (1) and/or inlet screen, clean/remove the dirt and debris.	Excessive dirt or debris is present in the fresh air inlet duct area and/or inlet screen area that restricts airflow.

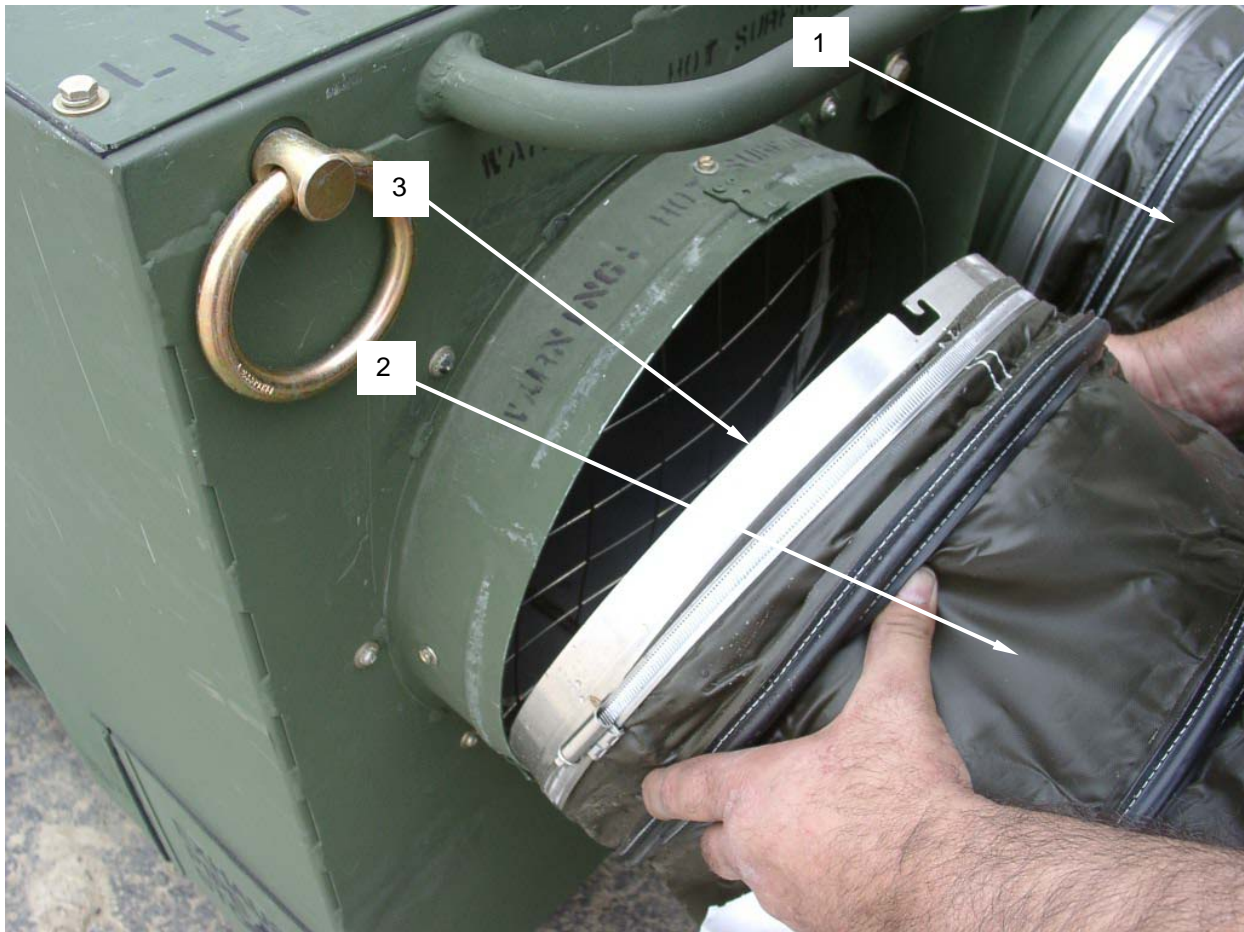

Table 1. Operator Preventive Maintenance Checks and Services.

ITEM NO.	INTERVAL	LOCATION ITEM TO CHECK/SERVICE	PROCEDURE	NOT FULLY MISSION CAPABLE IF:
2	Before	Operator Control Box	<p style="text-align: center;">CAUTION</p> <p>Be sure to perform ONLY a visual check of the POWER switch for damage. DO NOT flip the switch to the ON position.</p> <p>Perform a visual check of the operator control box (1) and verify that the POWER switch (2) and FUEL SELECTOR switch (3), FAULT RESET switch (4), VENT switch (5), and TEMPERATURE control (6) are undamaged.</p> <p>Check the LED display (7) and ensure that it is not cracked or otherwise damaged.</p> <p>Check that the thermistor (8) is not bent or otherwise damaged.</p>	<p>Operator control box is cracked, dented, or otherwise damaged as to prevent a weathertight seal or normal operation.</p> <p>POWER switch is damaged.</p> <p>FUEL SELECTOR switch is damaged.</p> <p>FAULT RESET switch is damaged.</p> <p>VENT switch is damaged.</p> <p>TEMPERATURE control is damaged.</p> <p>LED display is cracked or broken.</p> <p>Thermistor is bent or damaged.</p>
	During		Periodically monitor the operator control box (1) during operation of the LCFH. If fault code H561 or H562 appear while the LCFH continues to run, contact unit maintenance.	Fault codes appear during continuing operation of the LCFH.
3	Before	Operator Control Box Cable	Check operator control box cable (9) and verify that insulation and connectors are clean and undamaged.	<p>Operator control box cable insulation is cut or otherwise damaged exposing wires.</p> <p>Connectors are dented, bent, or otherwise damaged, preventing a secure connection to the operator control box or heater.</p>

Table 1. Operator Preventive Maintenance Checks and Services.

ITEM NO.	INTERVAL	LOCATION ITEM TO CHECK/SERVICE	PROCEDURE	NOT FULLY MISSION CAPABLE IF:
	During		Periodically monitor the routing of the cable (9) between heater and shelter to insure that it is not pinched or damaged. Control any situations that would pinch, cut or damage the cable.	Damage to cable interferes with operation.
	After		Perform the BEFORE checks prior to storing the box and cable in the LCFH operator control box compartment.	Damage to cable interferes with operation.

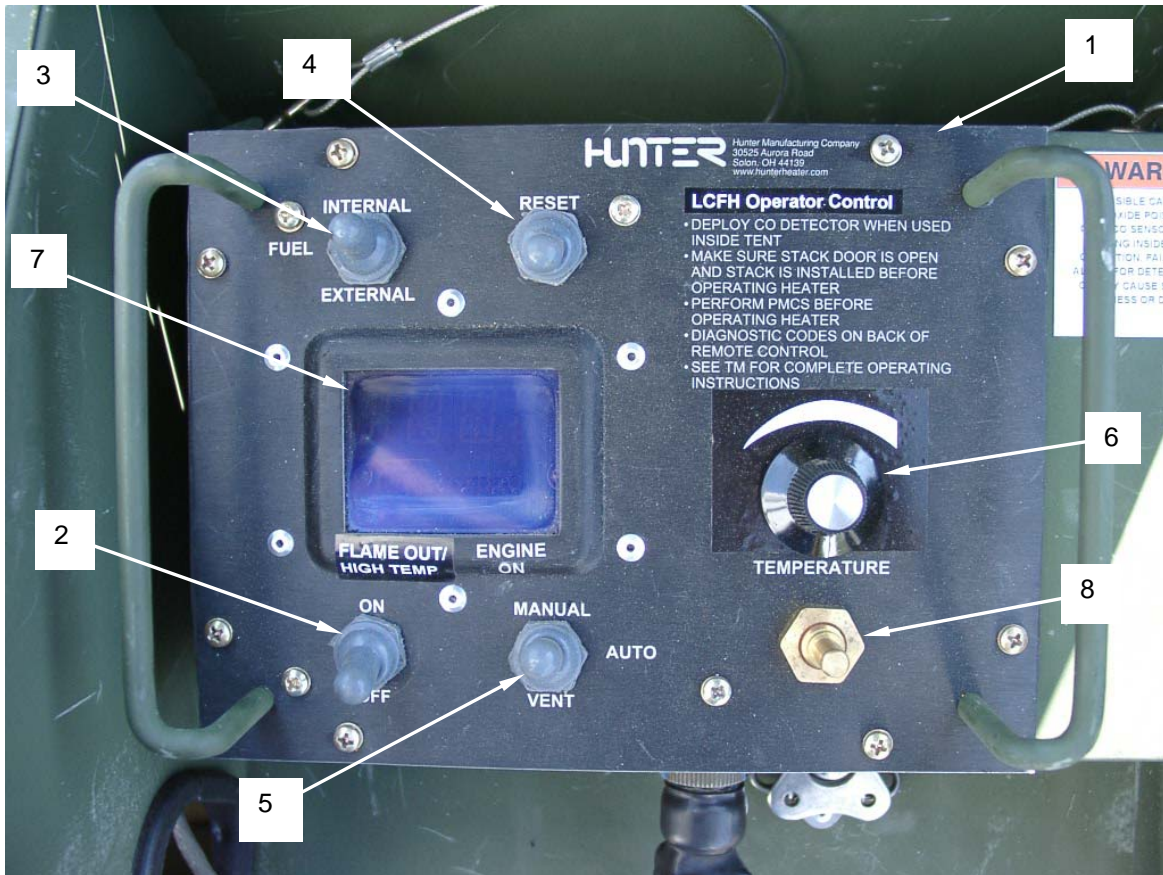

Table 1. Operator Preventive Maintenance Checks and Services.

ITEM NO.	INTERVAL	LOCATION ITEM TO CHECK/SERVICE	PROCEDURE	NOT FULLY MISSION CAPABLE IF:
4	Before	Batteries	<p>Open engine bay access door and inspect the two batteries (1 and 2) to ensure that there are no cracks, leaks, or other damage.</p> <p>Verify that the battery cables (3) are securely mounted to the batteries.</p> <p>Verify that the battery cable insulation is not cut, cracked, or otherwise damaged so as to expose the wires.</p> <p>Ensure that the battery mounting brackets (4) are secure and not bent, cracked or damaged.</p> <p>Ensure that the battery terminal protective covers (5) are in place and undamaged.</p>	<p>Battery cracked or otherwise damaged.</p> <p>Battery leaking.</p> <p>Battery cable not securely installed.</p> <p>Battery cable insulation cut or cracked.</p> <p>Battery mounting bracket is loose or damaged.</p> <p>Battery terminal protective covers are missing or damaged.</p>
	After		Visually check for leaks or damage and notify unit maintenance as required.	Damage that prevents safe use of the batteries.

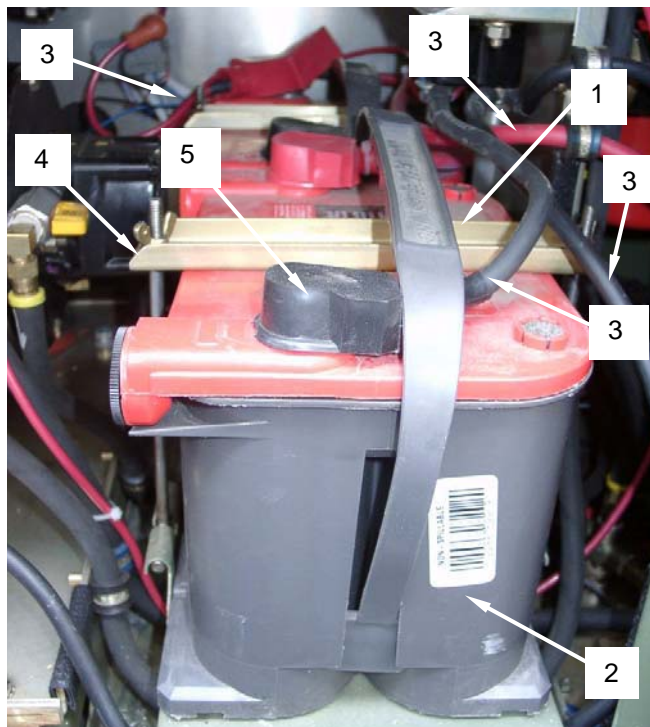

Table 1. Operator Preventive Maintenance Checks and Services.

ITEM NO.	INTERVAL	LOCATION ITEM TO CHECK/SERVICE	PROCEDURE	NOT FULLY MISSION CAPABLE IF:
5	Before	Fuel Supply Service Panel and External Fuel Hose	<p>Inspect the fuel service panel area and ensure that the external fuel supply connector (1) is clean and undamaged.</p> <p>Verify that the fuel filler cap (2) is present, undamaged, and that the fuel filler cap gasket (3) is in place.</p> <p>Remove the fuel filler screen (4) and inspect to ensure that there is no sand or other debris. Clean as necessary with clean fuel or solvent. Replace screen (4) and install fuel filler cap (2).</p> <p>Check external fuel hose (5) for cuts, cracks, dry rot or damaged end connectors. Replace if safe fuel transfer cannot be accomplished.</p>	<p>External fuel supply connector dirty, bent, or otherwise damaged.</p> <p>Fuel filler cap missing or damaged.</p> <p>Fuel filler cap gasket missing or damaged.</p> <p>Fuel filter screen is dirty and requires cleaning.</p>
	During		<p>If operating from internal fuel tank, periodically check fuel gauge and add fuel as required.</p> <p>If operating from external fuel source, periodically check the external fuel hose (5) for cuts, leaks or loose connections. If safe fuel transfer cannot be accomplished, remove and replace the hose.</p>	<p>Insufficient fuel in the tank to allow operation.</p> <p>Leaks or damage prevent safe transfer of fuel from the external source to the LCFH.</p>
	After		<p>Prior to storage in the fuel compartment door pocket: drain excess fuel from the external fuel hose (5) and check for cuts, cracks, dry rot or damaged end connectors. Replace if safe fuel transfer cannot be accomplished.</p>	<p>Damage would prevent safe transfer of fuel from the external source to the LCFH.</p>
6	Before, During, and After	Fuel Pump and Fuel Filter	<p>Open the fuel filter access door and verify that the fuel filter (6) is not cracked or otherwise damaged.</p> <p>Verify that there are no fuel leaks present around any of the fuel filter or fuel pump (7) fittings.</p>	<p>Fuel filter cracked or damaged.</p> <p>Fuel leaks present around fuel filter and/or fuel pump.</p>

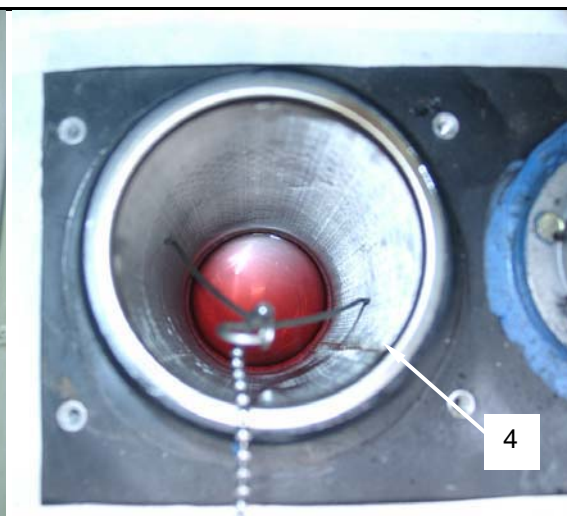
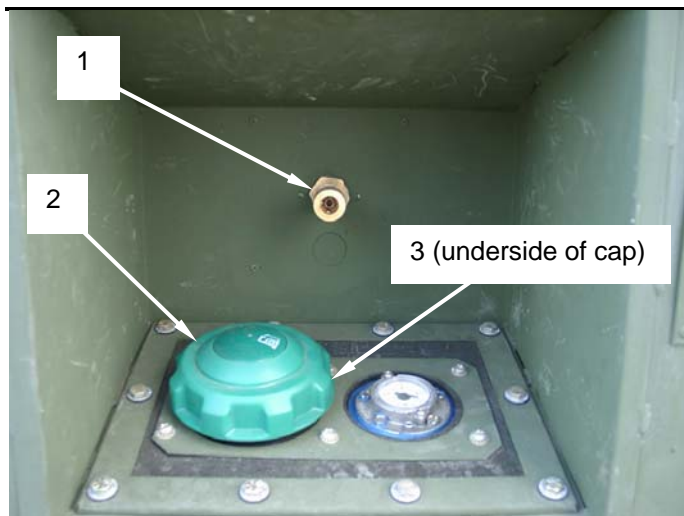

Table 1. Operator Preventive Maintenance Checks and Services.

ITEM NO.	INTERVAL	LOCATION	PROCEDURE	NOT FULLY MISSION CAPABLE IF:
		ITEM TO CHECK/SERVICE		
7	Before, During, and After	Exhaust stack assembly	<p>Inspect the exhaust stack assembly (1) and verify that the end (2) that engages with the heater exhaust stack outlet (3) is not bent, cracked, or damaged in any way as to prevent the exhaust stack from fitting securely and completely into the exhaust stack outlet.</p> <p>Verify that the downdraft cap (4) on the top of the exhaust stack is present and is not damaged.</p> <p>Verify that the heat shield (5) on the exhaust stack is present and undamaged.</p>	<p>Exhaust stack or exhaust stack outlet is bent, cracked, or damaged.</p> <p>Downdraft cap missing or inoperative.</p> <p>Heat shield missing or damaged so as to allow operator to come in contact with hot stack.</p>
8	Before, During, and After	Inlet and outlet duct housings	Inspect the inlet and outlet duct housings (6) to ensure that they are not bent or damaged so as to prevent the flexible ducts from engaging completely.	Inlet and/or outlet duct damaged in such a way as to prevent a good seal between the flexible duct and the duct housing.

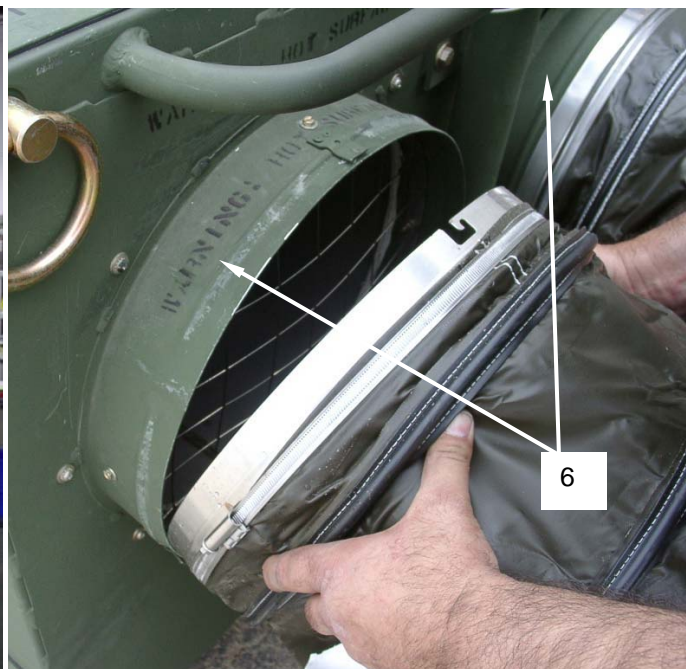
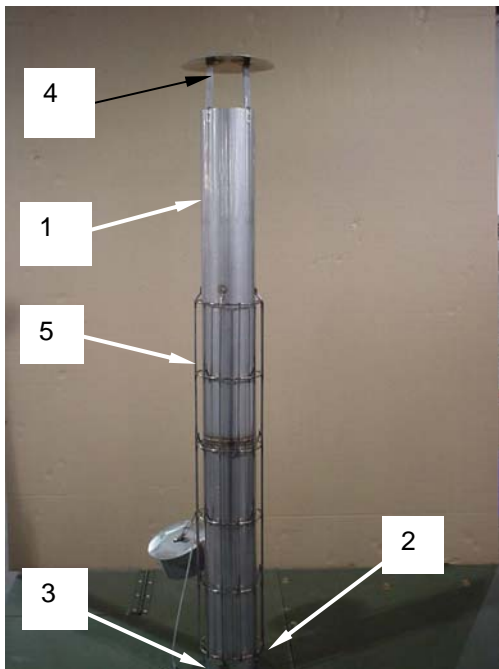

Table 1. Operator Preventive Maintenance Checks and Services.

ITEM NO.	INTERVAL	LOCATION ITEM TO CHECK/SERVICE	PROCEDURE	NOT FULLY MISSION CAPABLE IF:
9	Before and After	Engine Oil Level	<p>CAUTION</p> <p>Ensure battery shutoff switch is in the OFF position before checking oil level.</p> <p>Open the engine bay access door and check the level of the diesel engine oil. To check the oil level, the engine must be standing level and be switched off.</p> <ol style="list-style-type: none"> 1. Remove any dirt from the oil dipstick area. 2. Remove dipstick (1) and clean. 3. Insert dipstick but do not screw in, then remove. 4. Check dipstick oil level and, if necessary, add oil to the upper mark (2). 	Engine oil is below MAX mark.
10	Every 500 hours	Engine Air Filter Element	<p>Replace air filter element (3) at 500 hours and every 500 hours thereafter.</p> <p>Replace air filter element more frequently as required in dusty conditions.</p> <p>Inspect, clean, and replace air filter element as detailed in WP 0012.</p>	Air filter element dirty, clogged, or used in excess of stated PMCS interval.
11	Before, During, and After	Engine	Check for any oil or fuel leakage from engine.	Class III oil or fuel leaks present. Refer to unit maintenance.

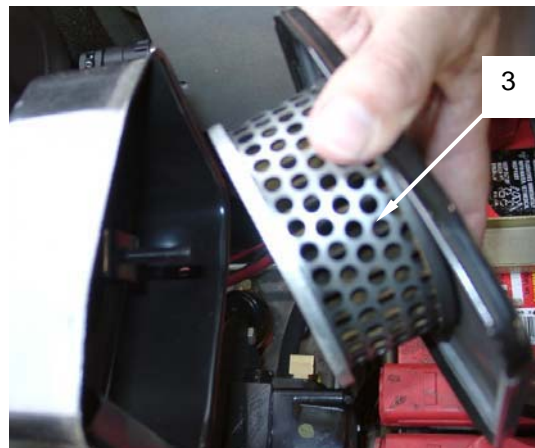
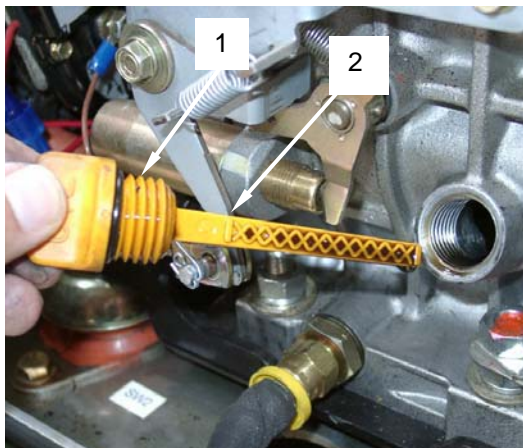

Table 1. Operator Preventive Maintenance Checks and Services.

ITEM NO.	INTERVAL	LOCATION	PROCEDURE	NOT FULLY MISSION CAPABLE IF:
		ITEM TO CHECK/SERVICE		
12	During	Fuel lines	<p style="text-align: center;"><u>WARNING</u></p> <p>Hearing protection should be worn when performing any troubleshooting or maintenance function requiring that the heater be operating with any of the access panels open. Failure to wear ear protection could result in hearing loss or damage.</p> <p>Do not place hands or inside heater while heater is operating. Placing hands inside heater when it is operating may cause serious injury or death.</p> <p>Inspect all fuel lines in heater and ensure that there are no leaks.</p>	Any Class III leaks that are observed. Heater can be operated with Class I or Class II leaks; however, note all leaks and notify unit maintenance.
13	During	Oil leaks	<p style="text-align: center;"><u>WARNING</u></p> <p>Hearing protection should be worn when performing any troubleshooting or maintenance function requiring that the heater be operating with any of the access panels open. Failure to wear ear protection could result in hearing loss or damage.</p> <p>Do not place hands inside heater while heater is operating. Placing hands inside heater when it is operating may cause serious injury or death.</p> <p>Inspect interior of heater and ensure that there are no oil leaks.</p>	Any Class III leaks that are observed. Heater can be operated with Class I or Class II leaks; however, note all leaks and notify unit maintenance.

Table 1. Operator Preventive Maintenance Checks and Services.

ITEM NO.	INTERVAL	LOCATION ITEM TO CHECK/SERVICE	PROCEDURE	NOT FULLY MISSION CAPABLE IF:
14	During	Carbon Monoxide Detector on Operator Control Box	Ensure that the hinged door (1) on the operator control box carbon monoxide detector (2) is in the down position and fully deployed.	Hinged door on carbon monoxide detector is in the closed position.
15	During	Fuel gauge	Inspect fuel gauge (3) and ensure that there is adequate fuel in the internal tank or in the external bulk fuel supply if applicable.	Low fuel level in internal tank or external fuel supply if used.

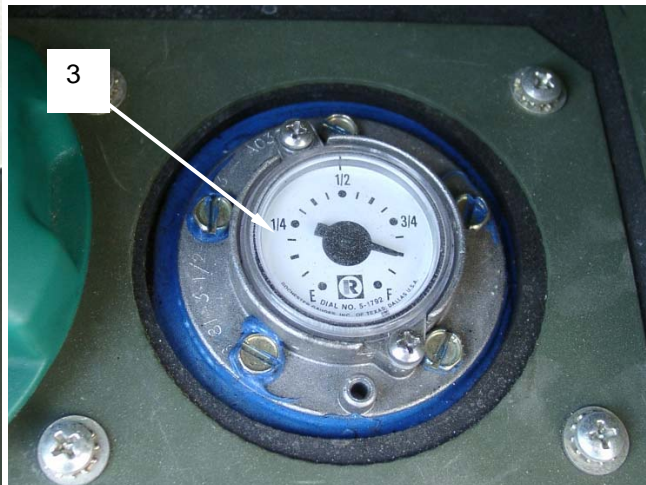
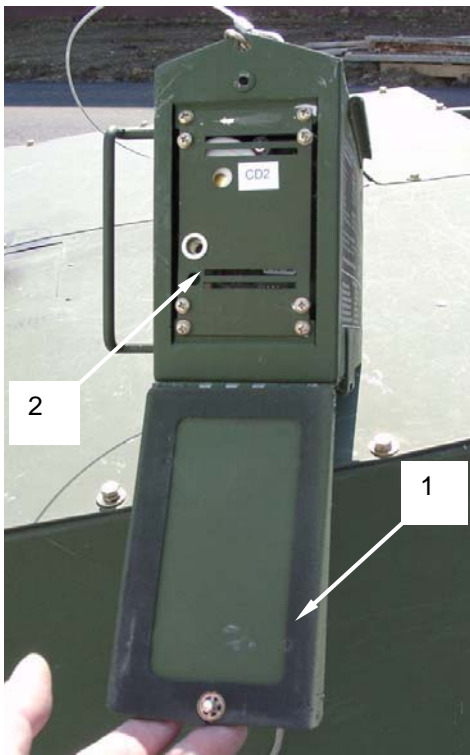

Table 1. Operator Preventive Maintenance Checks and Services.

ITEM NO.	INTERVAL	LOCATION ITEM TO CHECK/SERVICE	PROCEDURE	NOT FULLY MISSION CAPABLE IF:
16	After	Flexible Coupling	Open the engine bay access door and check the condition of the flexible coupling (1). Coupling should be aligned properly within the drive sections (2, 3) and should not have excessive wear or appear damaged in any way.	Flexible coupling misaligned with drive sections. Flexible coupling showing excessive wear or is damaged.

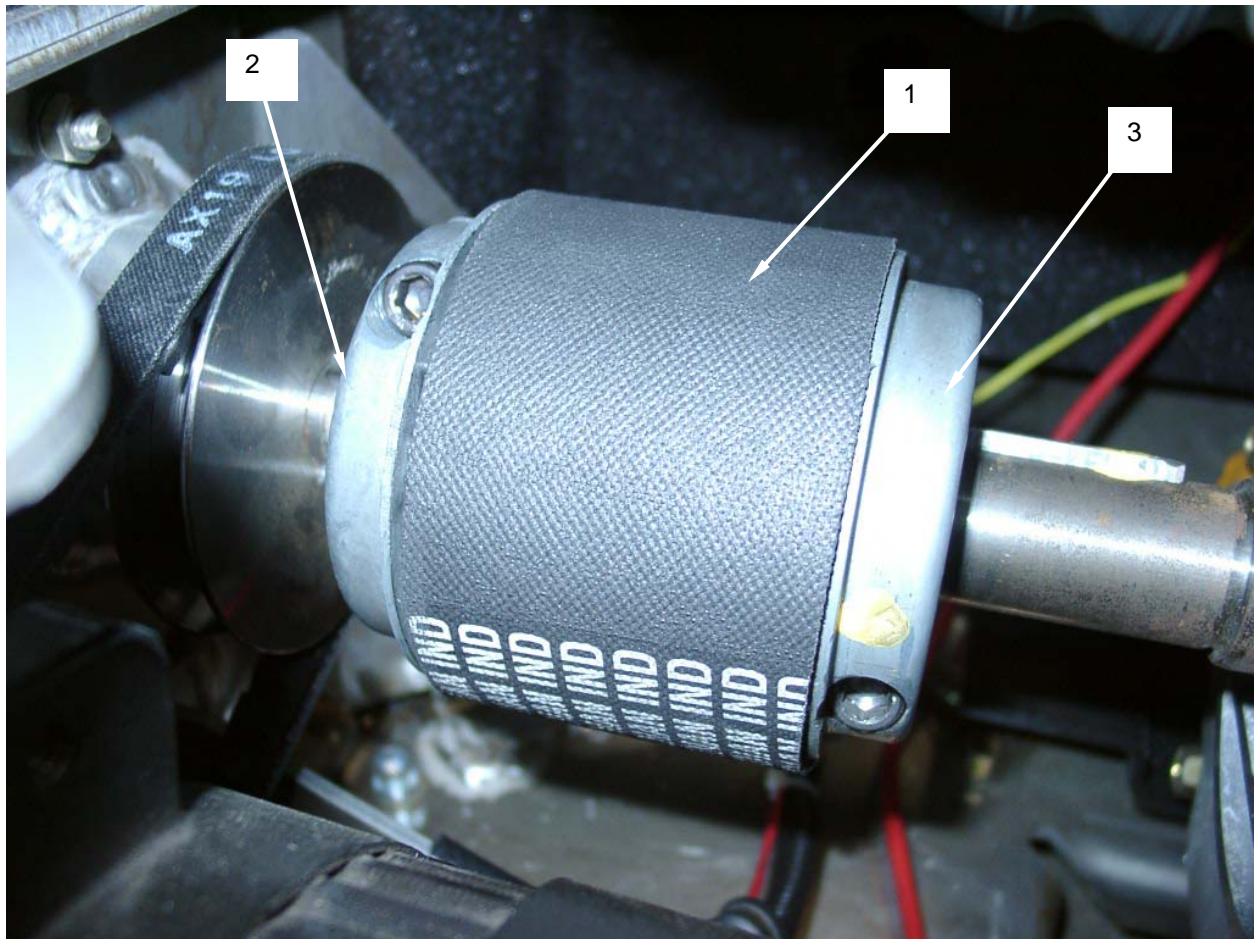
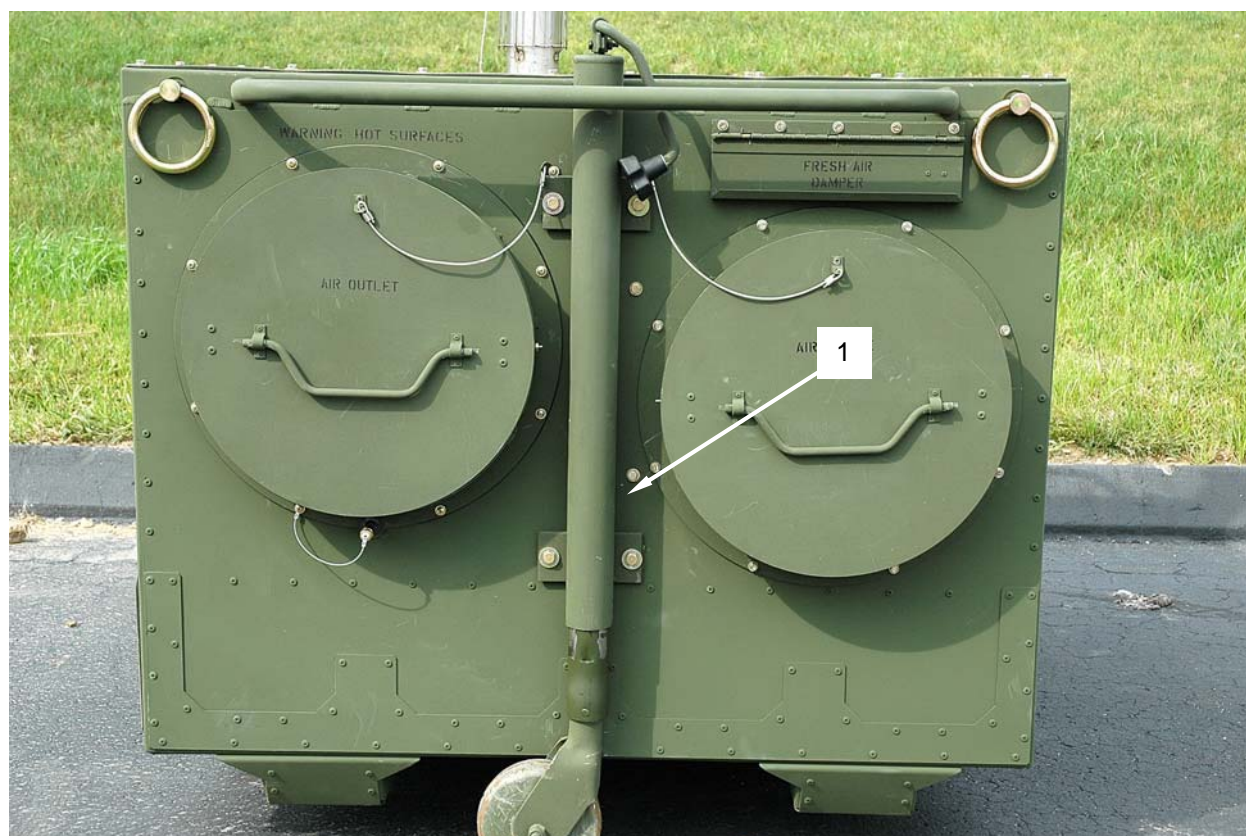

Table 1. Operator Preventive Maintenance Checks and Services.

ITEM NO.	INTERVAL	LOCATION ITEM TO CHECK/SERVICE	PROCEDURE	NOT FULLY MISSION CAPABLE IF:
17	Monthly	Jack Assembly	Fully extend and retract the jack assembly (1) to maintain lubrication on the internal screw.	Jack assembly is damaged or does not extend and retract fully.



END OF WORK PACKAGE

**OPERATOR, FIELD AND SUSTAINMENT MAINTENANCE
LARGE CAPACITY FIELD HEATER (LCFH)
OPERATOR MAINTENANCE INTRODUCTION**

INTRODUCTION

NOTE

Maintenance programs must be followed in the applicable technical manuals. It is very important to adhere to maintenance procedures in order to prolong the service life of these items.

This TM contains Operator Maintenance procedures applicable to the Large Capacity Field Heater (LCFH) as authorized by the Maintenance Allocation Chart (MAC) in Work Package 0092 00 of this manual. If applicable, refer to associated equipment technical manuals for item-specific maintenance instructions (refer to Work Package 0090 00 for technical manual information). All maintenance instructions covered in this Work Package are unique to the Large Capacity Field Heater.

All maintenance procedures in this work package can be performed by one person unless otherwise indicated. Read all **WARNINGS**, **CAUTIONS**, and **NOTES** carefully before attempting any procedures. This includes the warnings at the front of this manual.

Operator Maintenance Work Packages begin with a header specifying the applicable equipment, the item being maintained, and what the maintenance action entails. This is followed by a chart specifying the initial setup of the equipment before starting maintenance, the tools required to perform the maintenance, any materials or parts required, and the number of MOS specific personnel required. Maintenance items which do not list an MOS for the task are non-MOS specific Maintenance items.

Operator Maintenance tasks may be performed by Operator, Field or Sustainment Support personnel.

END OF WORK PACKAGE

OPERATOR MAINTENANCE**LARGE CAPACITY FIELD HEATER**

NSN 4520-01-500-1534

**AIR CLEANER
INSPECT, REPLACE**

INITIAL SETUP:**Tools**

None required

Personnel Required

MOS (non specific)

Materials/Parts

Rags, wiping (Item 4, WP 0119 00)

Equipment Condition

LCFH shutdown and cool

Main battery switch OFF and handle removed

**WARNING**

Do not attempt to inspect, clean, or replace the air cleaner on a hot engine. Performing maintenance on a hot engine may result in burns and severe injury.

INSPECT

1. Remove the wingnut **(1)**, washer **(2)**, and air cleaner cover **(3)**.
2. Pull out the filter element **(4)**.
3. Inspect the filter element for any accumulations of dust, dirt, or any other material that would restrict the flow of air to the engine. Replace the filter element as needed.

REPLACE

1. Remove the filter element **(4)** as described in INSPECT.
2. Install a new filter element **(4)**, ensuring that the new filter is seated securely on the filter element support **(5)**.
3. Install the air cleaner cover **(3)**.
4. Install the washer **(2)** and wingnut **(1)**. Tighten securely.

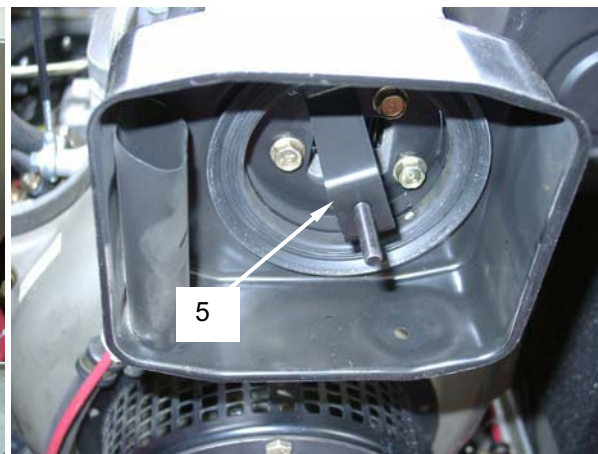
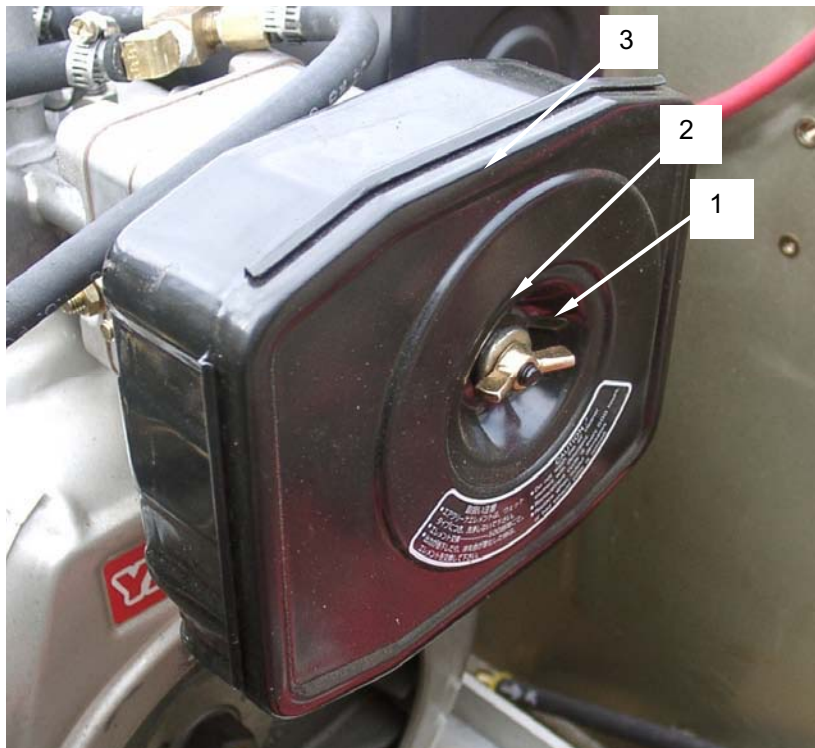

END OF WORK PACKAGE

OPERATOR MAINTENANCE**LARGE CAPACITY FIELD HEATER**

NSN 4520-01-500-1534

**CARBON MONOXIDE DETECTOR – OPERATOR CONTROL BOX
INSPECT, TEST**

INITIAL SETUP:**Tools**

None required

Personnel Required

MOS (non-specific)

Materials/Parts

None required

Equipment ConditionHeater shut down until instructed

NOTE

There are two carbon monoxide (CO) detectors used in the LCFH. One is located in the operator control box while the second is located inside the LCFH cabinet underneath the fan compartment cover. Only the detector in the operator control box can be inspected and tested at the operator level.

INSPECT

1. Unscrew the small thumb screw **(1)** on the cover **(2)** protecting the CO detector **(3)**.
2. Open the cover **(2)** and inspect the carbon monoxide detector **(3)** for dents, punctures, or any other damage that would prevent the detector from operating properly. If damaged, refer the entire operator control box to unit maintenance for carbon monoxide detector replacement.

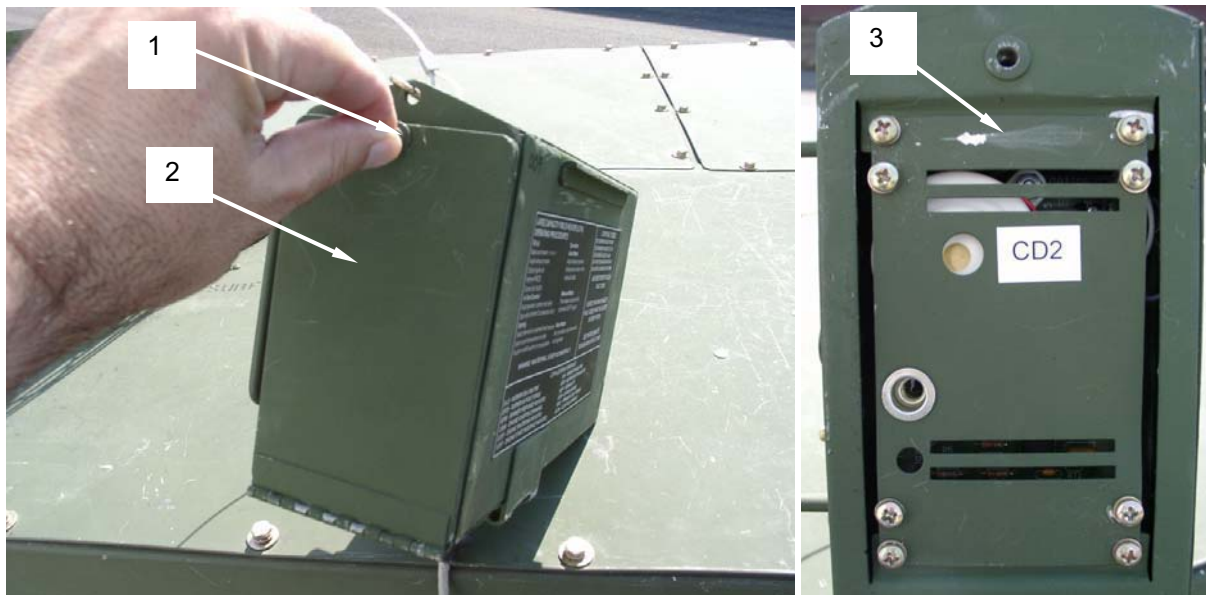

TEST

1. The carbon monoxide detector performs a self test when power to the LCFH is applied.
2. To test the CO detector, ensure that the power switch on the operator control box is in the ON position.
3. Unscrew the small thumb screw (1) on the cover (2) protecting the CO detector (3). Open the cover.
4. Within a few seconds, the carbon monoxide detector will produce a series of four chirps, followed by a delay of a few seconds, and then four more chirps. This indicates that the carbon monoxide detector is operating properly. If the detector does not chirp as described, notify unit maintenance.

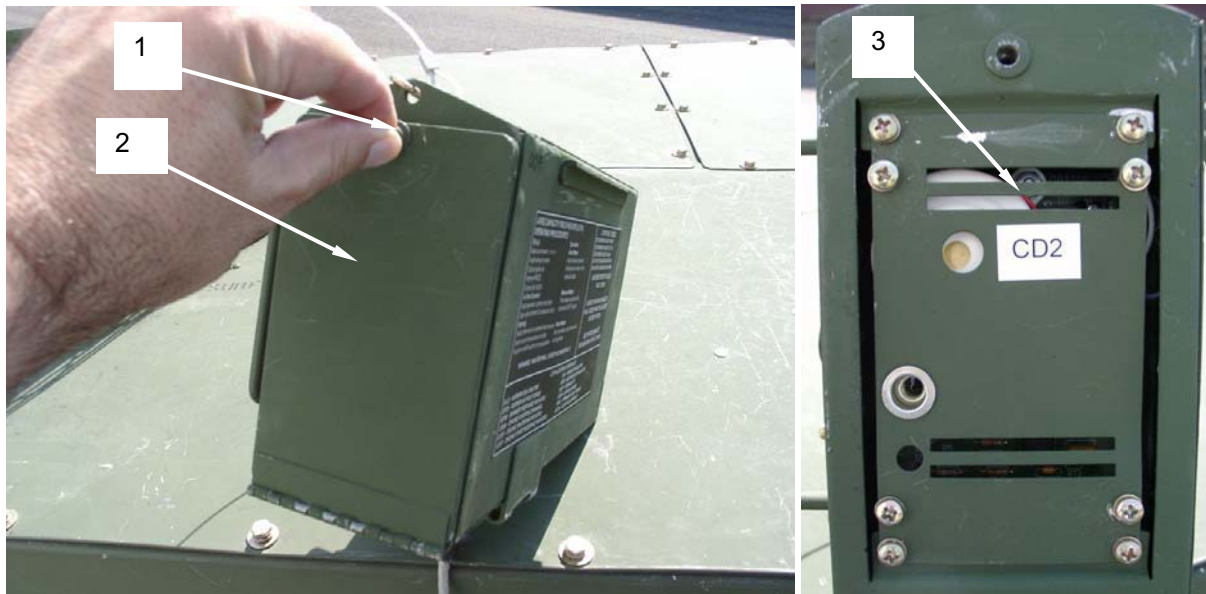
**END OF WORK PACKAGE**

OPERATOR MAINTENANCE**LARGE CAPACITY FIELD HEATER**

NSN 4520-01-500-1534

**WHEEL RETRACTION ASSEMBLY
REPLACE**

INITIAL SETUP:**Tools**

None required

Personnel Required

MOS (non-specific)

Materials/Parts

None required

Equipment Condition

Heater shut down and cool. (WP 0005 00)

REPLACE

1. Extend jack assembly at front of heater until wheels clear ground and permit adequate access to remove wheel retraction assembly **(1)**.
2. Pull the locking pin **(2)** that secures the wheel retraction assembly **(1)** to the wheel retraction bracket **(3)** on the cabinet **(4)**.
3. Take note of the position of the wheel retraction assembly **(1)** so that the new assembly can be installed in the same orientation.
4. Pull the wheel retraction assembly **(1)** from the wheel retraction bracket **(3)**.
5. Install a new wheel retraction assembly **(1)** into the wheel retraction bracket **(3)** taking care to orient the new assembly as noted earlier.
6. Install the locking pin **(2)**, securing the wheel retraction assembly in position.
7. Retract jack assembly until heater is returned to a level condition.

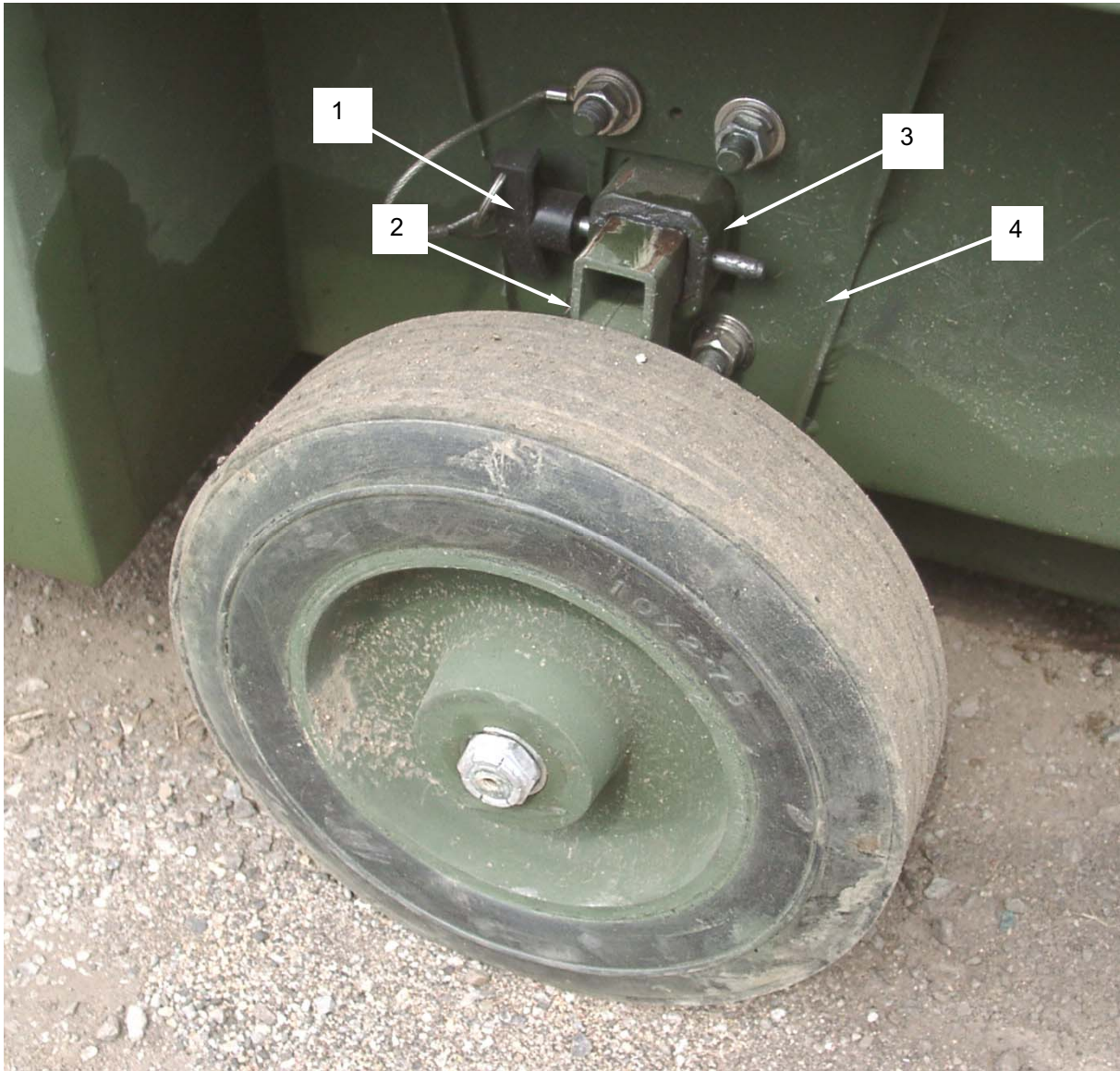

END OF WORK PACKAGE

CHAPTER 5
UNIT MAINTENANCE TROUBLESHOOTING PROCEDURES
LARGE CAPACITY FIELD HEATER (LCFH)

**UNIT MAINTENANCE
LARGE CAPACITY FIELD HEATER (LCFH)
MALFUNCTION SYMPTOM INDEX**

GENERAL

This chapter provides information to permit the maintainer to troubleshoot some problems that may occur during the course of LCFH operation.

MALFUNCTION SYMPTOM INDEX

The malfunction symptom index lists common malfunctions that may occur during the operation of the Large Capacity Field Heater. Find the malfunction to be eliminated and go to the indicated troubleshooting table in WP 0016 00. This index cannot list all malfunctions that may occur, all tests or inspections needed to find the fault, or all actions required to correct the fault. If the existing malfunction is not listed, or cannot be corrected through this troubleshooting index, notify unit maintenance.

In Table 2 below, a soft fault is defined as one in which the engine continues to operate but the burner is fault locked out; however the heater can be reset to attempt another burner run cycle. If the burner is running when a soft fault occurs, the heater will proceed to the post purge cycle followed by fault lock out.

If a hard fault occurs before the burner starts or after the burner has normally cycled off (due to temperature regulation) then the heater will not proceed to post purge and the engine will shut down.

The last ten fault codes that have been displayed on the operator control box can be displayed in reverse order by toggling the switch labeled RESET on the operator control box front panel. This is useful in the case of a fault code being displayed too quickly to note or if maintenance wishes to view the last ten fault codes.

Table 1. LCFH Fault Code Series Key.

Series	System Affected
100 series	Electrical
200 series	Burner
300 series	Carbon Monoxide (CO) sensor
400 series	Control panel
500 series	Engine
600 series	Solenoids
801	Software

Table 2. LCFH Unit Level Malfunctions

Malfunction	Troubleshooting Step
Engine will not crank	1
Engine will not start	2
Engine starts and stops.....	3
Engine output drops	4
Engine runs rough.....	5
Low compression pressure	6
Engine emits white smoke	7
Engine emits black smoke	8

No power when power switch is turned on9
 Heater will not start after 3 attempts 10
 Heater starts but sputters or runs erratically 11
 Heater runs then shuts down unexpectedly with no error code displayed on control panel..... 12
 Fuel leak is observed in the heater57
 The operator control panel is off, but the engine continues to run60

Heater starts, continues to run but displays one of the following fault codes shown in Table 3:

Table 3. LCFH Unit Level Soft Fault Codes.

Fault Code	Description	Troubleshooting Step
Soft Faults		
S221	Burner failed to start.....	15
S231	Flame detected in post-purge	16
S241	Flame not detected at flame sensor	17
S411	Heat exchanger airflow not detected	14
S412	Heat exchanger over temperature	13

Heater may or may not start, shuts down and displays following fault codes shown in Table 4:

Table 4. LCFH Unit Level Hard Fault Codes.

Fault Code	Description	Troubleshooting Step
Hard Faults		
H111	Alternator excitation open circuit	28
H112	Alternator excitation short circuit	29
H121	Alternator Tachometer loss of signal during engine run.....	23
H122	Alternator Tachometer not detected during Engine Crank.....	24
H123	Alternator tachometer signal present after engine shutdown.....	30
H124	Alternator tachometer signal present before engine start	31
H130	Battery Voltage Low/High (checked during engine operation 19.5V to 32V)	18
H131	Battery low voltage (checked during engine start 15V minimum)	19
H211	Burner Combustion Fan Low Current (2.5 amps)	20
H212	Burner combustion fan over current condition detected (checked after engine start)	32
H232	Burner Flame detected during burner pre-purge.....	22
H251	Spark ignition transformer relay open circuit T1	51
H252	Spark ignition transformer relay short circuit T1	52
H311	Carbon monoxide detected at operator control panel	54
H312	Carbon monoxide detected in inlet air	55
H321	Carbon monoxide (CO) inlet air sensor open circuit (driver side)	33

Fault Code	Description	Troubleshooting Step
H322	Carbon monoxide (CO) inlet air sensor short circuit (driver side)	34
H331	Carbon monoxide (CO) operator control panel sensor open circuit (driver side).....	35
H332	Carbon monoxide (CO) operator control panel sensor short circuit (driver side).....	36
H421	Operator control panel cable connection RS485 response timeout.....	26
H431	Outlet Temperature Sensor (RTD1) open circuit	57
H432	Outlet Temperature Sensor (RTD1) short circuit	58
H511	Engine fail to start after 3 tries.....	27
H521	Engine fuel pump (P1) open circuit	37
H522	Engine fuel pump (P1) short circuit	38
H531	Engine oil pressure before engine start.....	39
H532	Engine oil pressure low during engine run	21
H541	Engine pre-heat relay driver K1 open circuit	40
H542	Engine pre-heat relay driver K1 short circuit	41
H551	Engine starter relay driver open circuit.....	42
H552	Engine starter relay driver short circuit.....	43
H561	Engine throttle stop solenoid relay driver K2 Open Circuit.....	25
H562	Engine throttle stop solenoid relay driver K2 short circuit	44
H611	Fuel solenoid valve FS1 open circuit (burner on/off).....	45
H612	Fuel solenoid valve FS1 short circuit (burner on/off).....	46
H621	Fuel solenoid valve FS2 open circuit (burner high/low)	47
H622	Fuel solenoid valve FS2 short circuit (burner high/low)	48
H631	Fuel solenoid valve FS3 open circuit (internal/external fuel).....	49
H632	Fuel solenoid valve FS3 short circuit (internal/external fuel).....	50
H801	Watchdog (COP) Timeout (loss of software control for >1 sec).....	53

END OF WORK PACKAGE

**UNIT MAINTENANCE
LARGE CAPACITY FIELD HEATER (LCFH)
TROUBLESHOOTING PROCEDURES**

INITIAL SETUP:

Tools

Tool Kit, General Mechanics (Item 2, WP 0092 00)
Wrench, Torque (Item 19, WP 0092 00)
Micrometer, Caliper (Item 12, WP 0092 00)

Personnel Required

MOS 63J or 52C

Materials/Parts

None required

Equipment Condition

Heater shut down and cool unless otherwise indicated.
Main battery switch OFF and handle removed unless otherwise indicated.
Flip power switch to OFF position before attempting corrective action.



WARNING

Hearing protection should be worn when performing any troubleshooting or maintenance function requiring that the heater be operating with any of the access panels open. Failure to wear ear protection could result in hearing loss or damage.

Table 1. Troubleshooting Procedure for Large Capacity Field Heater (LCFH).

MALFUNCTION	TEST OR INSPECTION	CORRECTIVE ACTION
1. Engine will not crank	Step 1. Test starter motor to determine if brushes require replacement or if starter motor is defective.	Step 1. Remove and replace starter motor (WP 0044 00).
2. Engine will not start	Step 1. Check for improper valve / rocker arm clearance.	Step 1. Adjust valve clearance (WP 0041 00).
	Step 2. Check for kinked, blocked, or clogged fuel line.	Step 2. Adjust fuel line and/or clear line of blockage.
	Step 3. Check for clogged, sticking, or worn fuel injector nozzle.	Step 3. Remove and replace fuel injector (WP 0043 00).
3. Engine starts and stops		Step 4. Refer problem to direct support maintenance level.
	Step 1. Check for damaged air heater or air heater electrical leads.	Step 1. Remove and replace air heaters (WP 0042 00).
	Step 2. Check for kinked or clogged fuel line.	Step 2. Adjust fuel line and/or clear line of blockage.
	Step 3. Check for clogged, sticking, or worn fuel injector nozzle.	Step 3. Remove and replace fuel injector (WP 0043 00).
		Step 4. Refer problem to direct support maintenance level.

Table 1. Troubleshooting Procedure for Large Capacity Field Heater (LCFH).

MALFUNCTION	TEST OR INSPECTION	CORRECTIVE ACTION
4. Engine output drops	Step 1. Check for clogged or dirty air cleaner. Step 2. Check for improper valve / rocker arm clearance. Step 3. Check for clogged, sticking, or worn fuel injector nozzle.	Step 1. Remove and replace air cleaner element (WP 0042 00). Step 2. Adjust valve clearance (WP 0041 00). Step 3. Remove and replace fuel injector (WP 0043 00).
5. Engine runs rough	Step 1. Check for clogged, sticking, or worn fuel injector nozzle.	Step 1. Remove and replace fuel injector (WP 0043 00). Step 2. Refer problem to direct support maintenance level.
6. Low compression pressure	Step 1. Check for improper valve / rocker arm clearance. Step 2. Check for leaks around fuel injector.	Step 1. Adjust valve clearance (WP 0041 00). Step 2. Tighten injector nuts to 84 to 104 inch-pounds (100 to 120 kg-cm) (WP 0043 00). Step 3. Refer problem to direct support maintenance level.
7. Engine emits white smoke	Step 1. Check to see if engine oil level is too high. Check for contaminants in the oil system Step 2. Check for improper valve / rocker arm clearance.	Step 1. Drain and service engine oil (WP 0046 00). Step 2. Adjust valve clearance (WP 0041 00). Step 3. Refer problem to direct support maintenance level.
8. Engine emits black smoke	Step 1. Check for clogged or dirty air filter. Step 2. Check for clogged, sticking, or worn fuel injector nozzle.	Step 1. Remove and replace air filter (WP 0012 00). Step 2. Remove and replace fuel injector (WP 0043 00). Step 3. Refer problem to direct support maintenance level.

Table 1. Troubleshooting Procedure for Large Capacity Field Heater (LCFH).



MALFUNCTION	TEST OR INSPECTION	CORRECTIVE ACTION
<p>9. No power when power switch is turned on.</p>	<div style="text-align: center;">  WARNING </div> <p>The equipment being tested or corrected operates at voltage and current that can cause serious injury or death.</p> <p>Step 1. Open side access door and verify that both batteries are installed and that the cables are attached securely. Verify that batteries are fully charged.</p>	<div style="text-align: center;">  WARNING </div> <p>The equipment being tested or corrected operates at voltage and current that can cause serious injury or death.</p> <p>Step 1. Install two batteries that are known to be in good condition and are approved for use with the LCFH. Tighten all battery terminal connections. Repair any cables or terminal connectors that are damaged.</p>
<p>10. Heater will not start after 3 attempts</p>	<p>Step 1. The heater will attempt to restart 5 times on its own. Determine if the heater has completed a restart cycle attempt.</p>	<p>Step 1. Attempt up to three restart cycles in 60 minutes.</p> <p>Step 2. If further corrective action is required, notify Direct Support Maintenance.</p>
<p>11. Heater starts but sputters or runs erratically</p>	<p>Step 1. Determine if fuel filter needs servicing.</p>	<p>Step 1. Service fuel filter and attempt restart. If problem persists, change fuel filter IAW WP 0027 00. Attempt restart of heater.</p> <p>Step 2. Drain fuel tank and fill with approved fuel IAW 0034 00 that is known to be clean and free of contaminants.</p> <p>Step 3. If problem has not been resolved, notify Direct Support Maintenance.</p>
<p>12. Heater runs then shuts down unexpectedly with no fault code displayed on control panel</p>	<p>Step 1. If operating the heater from a bulk fuel supply, determine if external fuel hose is kinked or damaged.</p>	<p>Step 1. Eliminate any kinks in the external fuel hose. Repair any damage to the fuel hose or the quick disconnect connectors IAW WP 0068 00.</p> <p>Step 2. If heater runs then shuts down unexpectedly again, notify Direct Support maintenance for further corrective action.</p>

Table 1. Troubleshooting Procedure for Large Capacity Field Heater (LCFH).

MALFUNCTION	TEST OR INSPECTION	CORRECTIVE ACTION
<p>13. Heater smokes excessively during B LO or B HI.</p>	<p>Step 1. Determine Operational Altitude.</p> <p>Step 2. Check to make sure that during the Low Fire operation (B LO on Operator Control Display) the Burner Fuel Pressure gage located on the back plate of burner assembly reads approx 35 - 45 psi.</p> <p>Step 3. Check to make sure that there are no obstructions to the burner combustion air inlet from dirt or debris and that combustion air blower wheel spins freely.</p> <p>Step 4. Using a Voltage Meter, make sure that the voltage at the Combustion Blower motor is approx. 25.5 VDC during the High Fire operation (B HI on Operator Control Display).</p> <p>Step 5. Remove the burner and inspect for signs of excessive soot buildup.</p>	<p>If altitude is above 6000 ft, refer to WP 0033 00 for burner fuel pressure adjustment procedures.</p> <p>If fuel pressure is higher than 50 psi during B LO: Step 1: Inspect Burner Nozzle assembly IAW WP 0050 00. Step 2: Inspect FS2 IAW WP 0032 00.</p> <p>Remove all debris. Remove and Inspect Combustion Blower IAW WP0049.</p> <p>If Voltage is incorrect during B HI: Step 1: Inspect Combustion Blower IAW WP 0049 00. Step 2: Reset CB1. Step 3: Replace Main Printed Circuit Board IAW WP 0063 00.</p> <p>Service Burner and Electrode Nozzle Assembly IAW WP0050.</p>
<p>14. Heater starts, displays error code: S412 but continues to run</p>	<p>Step 1. This error code indicates that the heat exchanger over-temperature switch SW4 has been activated. Turn power switch to OFF. Check Fuel Solenoid Valve FS2 IAW WP 0032 00 to determine if it is stuck in a Closed/Hi Fire Position. Check pressure on nozzle pressure gauge near burner and verify that pressure is approximately 50 psi when burner is first started.</p>	<p>Step 1. If pressure at burner startup is at high fire pressure of 80-90 psi, this would be cause of S412 soft fault. All troubleshooting must be done within 15 seconds of startup as this ensures a Lo-Fire condition in the burner.</p> <p>Step 2. Shut down heater and disconnect fuel line from fuel valve solenoid FS2 (WP 0032 00) and place end of hose into approved container. Start heater. If, after disconnection, gauge still reads 80-90 psi then there may be a blockage somewhere between fitting and check valve or inside brass nozzle adapter. Check for contamination of check valve or nozzle adapter.</p> <p>Step 3. If after disconnection of fuel line in Step 2, pressure on gauge falls to approximately 50 psi, then fuel solenoid valve FS2 requires replacement IAW WP 0032.</p>

Table 1. Troubleshooting Procedure for Large Capacity Field Heater (LCFH).

MALFUNCTION	TEST OR INSPECTION	CORRECTIVE ACTION
15. Heater starts, displays error code: S411 but continues to run	Step 1. This error code indicates that the heat exchanger airflow has been blocked or restricted. Turn power switch to OFF and inspect air inlet duct.	<p>Step 1. Verify that there are no obstructions to the air inlet duct. Flip RESET switch and attempt restart.</p> <p>Step 2. Check for loose inlet fan. A visible wobble or rubbing on the fan housing would be evidence that inlet fan is loose. If this is suspected, retighten inlet fan assembly IAW WP 0038 00. If inlet fan is not functioning, replace IAW WP 0038 00.</p> <p>Step 3. Check air sensor hose from bulkhead to main control box and ensure that it is connected and not kinked, cut, or damaged in any way. If missing or damaged, replace by cutting a length of hose from bulk supply.</p>
16. Heater starts, displays error code: S221 but burner fails to start	Step 1. This error code indicates that burner failed to start after 3 attempts. The diesel engine and other systems may operate but the burner failed to start.	<p>Step 1. Turn power switch to OFF. Open the burner access door and ensure that the flame sensor wire harness connector is connected securely. Flip RESET switch and attempt restart.</p> <p>Step 2. If flame sensor is connected securely and problem occurs again, replace flame sensor IAW WP 0053 00.</p>
17. Heater starts, runs properly but displays error code: S231 when the system is in post-purge mode	<p>Step 1. This error code indicates that there was a burner flame detected during burner post-purge.</p> <p>Step 2. Determine if flame sensor is detecting light when it shouldn't be.</p> <p>Step 3. Determine if fuel solenoid valve FS1 has failed to open.</p>	<p>Step 1. This problem may be caused by excess fuel in the burner during system post-purge or by excess carbon in the burner. Restart heater and attempt to recreate problem. If problem doesn't reappear, it may be a one time occurrence.</p> <p>Step 2. Clean burner cone of excess carbon IAW WP 0051 00.</p> <p>Step 3. Ensure that flame sensor is firmly seated in burner flame sensor tube. If firmly seated, replace flame sensor IAW 0053 00.</p> <p>Step 4. Ensure fuel solenoid valve FS1 has opened properly.</p>

Table 1. Troubleshooting Procedure for Large Capacity Field Heater (LCFH).

MALFUNCTION	TEST OR INSPECTION	CORRECTIVE ACTION
<p>18. Heater starts, runs for a time, and then displays error code: S241</p>	<p>Step 1. This error code indicates that the burner had a loss of flame while running.</p> <p>Step 2. Remove fuel nozzle and ensure that it is not clogged.</p> <p>Step 3. Remove burner cone and remove any excess carbon buildup.</p> <p>Step 4. Fuel filter may require replacement.</p>	<p>Step 1. Turn power switch to OFF. Open the burner access door and ensure that the flame sensor wire harness connector is connected securely. Flip RESET and attempt restart. If securely connected and problem persists, replace flame sensor IAW WP 0053 00.</p> <p>Step 2. Remove and clean fuel nozzle IAW 0050 00.</p> <p>Step 3. Remove and clean burner cone IAW WP 0051 00.</p> <p>Step 4. Replace fuel filter IAW 0027 00.</p>
<p>19. Heater starts, shuts down, and displays error code: H130</p>	<p>Step 1. This error code indicates that the batterie voltage is outside the operating range of a minumum 19.5 Volts and a maximum of 32 Volts.</p>	<p>Step 1. Turn power switch to OFF. Open engine bay access door and inspect the wires going to the alternator and ensure that they are all connected properly and that they are not cut or damaged in any way. Ensure the the excitation wire (low) is connected properly and not damaged. Ensure that the alternator output wire (low) is not broken or damaged. Repair any broken or damaged wires.</p> <p>Step 2. Ensure that the alternator belt is not loose. If loose, adjust the belt IAW WP 0039 00.</p> <p>Step 3. Ensure that all of the battery cable connections are secure and that the cables are not damaged in any way. Replace any damaged cables IAW WP 0057 00.</p> <p>Step 4. Test batteries IAW 0058 00. Replace one or more defective batteries.</p> <p>Step 5. Test output of alternator. If no output voltage or low output voltage, replace alternator IAW 0039 00.</p>

Table 1. Troubleshooting Procedure for Large Capacity Field Heater (LCFH).

MALFUNCTION	TEST OR INSPECTION	CORRECTIVE ACTION
<p>20. Heater starts, shuts down, and displays error code: H131</p>	<p>Step 1. This error code indicates that the system is experiencing a battery low voltage condition (battery must have 15V minimum). Turn power switch to OFF. Measure battery voltage at slave connector and ensure that it is between 15V and 24V.</p> <p>Step 2. Check alternator belt and ensure that it is not damaged or loose.</p> <p>Step 3. Check alternator output wire and ensure that it is not broken, damaged, or not connected.</p> <p>Step 4. Check all battery connections and ensure that all are secure and undamaged.</p> <p>Step 5. Check battery output voltage and ensure that it is between 15V and 24V.</p> <p>Step 6. Check output of alternator during operation and ensure that voltage on the output wire is between 19.5V and 35V.</p>	<p>Step 1. Check outdoor temperature. If temperature is -40°F or lower, use the slave connector to provide supplemental source of 24VDC power to heater. If batteries are still low or defective, replace batteries IAW WP 0058 00.</p> <p>Step 2. Ensure that the alternator belt is not loose. If alternator belt is loose, adjust IAW WP 0039 00.</p> <p>Step 3. Open engine bay access door and inspect the wires going to the alternator and ensure that they are all connected properly and that they are not cut or damaged in any way.</p> <p>Step 4. Ensure that all of the battery cable connections are secure and that the cables are not damaged in any way.</p> <p>Step 5. Replace battery if voltage is below 15VDC.</p> <p>Step 6. Test output of alternator. If no output voltage or low output voltage, replace alternator IAW 0039 00.</p>
<p>21. Heater starts, shuts down, and displays error code: H211</p>	<p>Step 1. This error code indicates that there is a low current condition at the burner combustion fan. Turn power switch to OFF. Check combustion fan wiring harness and connector and ensure that wire is not broken or damaged. Ensure that both halves of connector are securely mated.</p> <p>Step 2. Check combustion fan and ensure that it is functioning correctly.</p>	<p>Step 1. Securely mate both halves of the combustion fan wire harness connector. Repair or replace damaged combustion fan wiring harness.</p> <p>Step 2. Replace a defective combustion fan IAW WP 0049 00.</p>

Table 1. Troubleshooting Procedure for Large Capacity Field Heater (LCFH).

MALFUNCTION	TEST OR INSPECTION	CORRECTIVE ACTION
22. Heater starts, shuts down, and displays error code: H532	<p>Step 1. This error code indicates that the oil pressure of the diesel engine during operation is low. Turn power switch to OFF. Check oil level of diesel engine and ensure that level is adequate. Ensure there is adequate fuel in the fuel tank.</p> <p>Step 2. Check diesel engine oil pressure switch wire and ensure that it is not shorted.</p> <p>Step 3. Check diesel engine oil pressure switch and ensure that it is working properly.</p>	<p>Step 1. Add engine oil to full mark. Refill fuel tank.</p> <p>Step 2. Repair or replace a shorted diesel engine oil pressure switch wire.</p> <p>Step 3. Replace a defective diesel engine oil pressure switch.</p>
23. Heater starts, shuts down, and displays error code: H232	<p>Step 1. This error code indicates that a flame was detected during burner pre-purge. Turn power switch to OFF. Open burner access door and ensure that flame sensor is securely installed in flame sensor tube.</p> <p>Step 2. Check to ensure that excess fuel is not still burner in burner after heater has been shut down.</p> <p>Step 3. Ensure fuel solenoid valve FS1 opens at heater startup by verifying pressure indicated on gauge at rear of burner reads between low fire pressure of approximately 50 psi and high fire pressure of 80 to 90 psi. If FS1 is not opening properly, pressure read 0 psi.</p>	<p>Step 1. Seat flame sensor securely in flame sensor tube.</p> <p>Step 2. View through burner sight glass and determine if there is still fuel burning after heater shutdown. Allow excess fuel to burn out then attempt restart.</p> <p>Step 3. Replace defective solenoid valve FS1 IAW WP 0031 00.</p>
24. Heater starts, shuts down, and displays error code: H121	<p>Step 1. This error code indicates that a loss of signal from the alternator tachometer occurred during operation. Turn power switch to OFF. Inspect engine bay, fuel access, and burner areas for any signs of fuel loss.</p> <p>Step 2. Check alternator TACH wire and ensure that it is not disconnected, broken, or damaged in any way.</p> <p>Step 3. Check and ensure that the alternator belt is not broken or damaged.</p> <p>Step 4. Check and ensure that flexible coupling is not broken or damaged.</p>	<p>Step 1. Ensure that there is adequate fuel in the heater. Repair any damaged or defective fuel hoses or connections that are leaking fuel.</p> <p>Step 2. Reconnect alternator tach wire if disconnected and tighten securely. Repair any broken or damaged alternator tach wire.</p> <p>Step 3. Replace a broken or damaged alternator belt IAW WP 0039 00.</p> <p>Step 4. Replace a damaged or broken flexible coupling IAW WP</p>

Table 1. Troubleshooting Procedure for Large Capacity Field Heater (LCFH).

MALFUNCTION	TEST OR INSPECTION	CORRECTIVE ACTION
<p>25. Heater starts, shuts down, and displays error code: H122</p>	<p>Step 1. This error code indicates that the alternator tachometer was not detected during engine crank. During heater startup, determine if diesel engine starter is turning.</p> <p>Step 2. Turn power switch to OFF. Check and ensure that alternator TACH wire is connected properly and does not read open when checked with a multimeter.</p> <p>Step 3. Check and ensure that the alternator belt is not broken or damaged.</p> <p>Step 4. Check and ensure that flexible coupling is not broken or damaged.</p>	<p>0040 00.</p> <p>Step 1. If starter does not turn during heater startup, replace starter IAW WP 0044 00.</p> <p>Step 2. Repair a damaged or defective alternator TACH wire.</p> <p>Step 3. Replace a broken or damaged alternator belt IAW WP 0039 00.</p> <p>Step 4. Replace a damaged or broken flexible coupling IAW WP 0040 00.</p>
<p>26. Heater starts, shuts down, and displays error code: H561</p>	<p>Step 1. This error code indicates that there is an open circuit detected at the engine throttle stop solenoid relay driver K2 inside the relay box assembly (see WP 0062 00). Turn power switch to OFF. Open engine bay access door and inspect relay box assembly to ensure that wiring harness is not damaged and that the connectors are engaged securely.</p> <p>Step 2. Check and ensure that throttle stop relay driver K2 is operating properly.</p>	<p>Step 1. Check all wires leading to relay box assembly (see WP 0062 00 for location). Reconnect or repair any wires or connectors that may be disconnected or damaged.</p> <p>Step 2. Remove relay box assembly IAW WP 0062 00 and ensure that all wires are connected to relays.</p> <p>Step 3. Replace a defective throttle stop solenoid relay driver K2.</p>

Table 1. Troubleshooting Procedure for Large Capacity Field Heater (LCFH).

MALFUNCTION	TEST OR INSPECTION	CORRECTIVE ACTION
27. Heater starts, shuts down, and displays error code: H421	<p>Step 1. This error code indicates that the system is not receiving a response from the operator control box. Turn power switch to OFF. Ensure that the connection between the operator control box and the operator control box cable is secure. Ensure that the connector is not damaged in any way and that the cable is not cut or damaged.</p> <p>Step 2. Ensure that the connection between the main control box and the operator control box cable is secure. Ensure that the connector is not damaged in any way and that the cable is not cut or damaged.</p>	<p>Step 1. Tighten connection between operator box control cable and operator control box. Tighten connection between operator box control cable and main control box control box.</p> <p>Step 2. Replace a damaged or defective operator control box control cable.</p>
28. Heater starts, shuts down, and displays error code: H511	<p>Step 1. This error code indicates that the engine failed to start after 3 tries. Turn power switch to OFF. Open engine bay access door and inspect location of engine throttle. Ensure that the engine throttle cable is not stuck in OFF position.</p> <p>Step 2. Check and ensure that fuel pump is operating properly.</p> <p>Step 3. Check fuel filter and determine if replacement is required.</p> <p>Step 4. Check diesel engine starter and ensure that it is turning with sufficient RPM to start engine.</p>	<p>Step 1. Lubricate engine throttle cable.</p> <p>Step 2. Replace a broken or defective engine throttle cable.</p> <p>Step 3. Replace a broken or defective engine throttle stop solenoid.</p> <p>Step 4. Replace a defective fuel pump.</p> <p>Step 5. Replace fuel filter if required.</p> <p>Step 6. Replace a starter that is not turning with sufficient RPM to start engine.</p>
29. Heater starts, shuts down, and displays error code: H111	<p>Step 1. This error code indicates that there is an open circuit on the alternator excitation line. Turn power switch to OFF. Check the alternator excitation wire (see WP 0039 00 for location) and ensure that it is connected securely and not broken or damaged in any way.</p> <p>Step 2. Check alternator output and determine if alternator is operating correctly.</p>	<p>Step 1. Secure a loose alternator excitation wire. Repair a broken or damaged wire.</p> <p>Step 2. Replace a defective alternator IAW WP 0039 00.</p>

Table 1. Troubleshooting Procedure for Large Capacity Field Heater (LCFH).

MALFUNCTION	TEST OR INSPECTION	CORRECTIVE ACTION
<p>30. Heater starts, shuts down, and displays error code: H112</p>	<p>Step 1. This error code indicates that there is an short circuit on the alternator excitation line. Turn power switch to OFF. Check the alternator excitation wire (see WP 0039 00 for location) and ensure that the insulation has not been damaged and that the wire has not been shorted to ground.</p>	<p>Step 1. Repair a broken or damaged alternator excitation wire. Ensure that it is not shorted to ground.</p> <p>Step 2. Replace a defective alternator IAW WP 0039 00.</p>
<p>31. Heater starts, shuts down, displays error code: H123 but engine continues to run</p>	<p>Step 1. This error code indicates that the alternator tachometer signal is present after shutdown. Turn power switch to OFF. Check the engine throttle shutdown cable and ensure that it is not sticking.</p>	<div data-bbox="1149 569 1321 653" style="text-align: center;">  </div> <p style="text-align: center;">WARNING</p> <p>Hearing protection should be worn when performing any troubleshooting or maintenance function requiring that the heater be operating with any of the access panels open. Failure to wear ear protection could result in hearing loss or damage.</p> <p>Carefully place hand inside heater and touch engine throttle only. Do not place hands or inside heater while heater is operating. Placing hands inside heater when it is operating may cause serious injury or death.</p> <p>Step 1. Don hearing protection and open engine bay access door. Move bottom of engine throttle where cable is connected and move to the left (see WP 0026 00 for location). Hold throttle lever in this position until engine comes to a fuel stop.</p> <p>Step 2. Lubricate the engine throttle shutdown cable IAW WP 0026 00 and ensure that it is not sticking.</p> <p>Step 3. Replace a defective engine throttle shutdown cable IAW WP 0026 00.</p> <p>Step 4. Ensure that engine throttle shutdown solenoid wire is connected. See WP 0026 00 for location.</p> <p>Step 5. Replace a defective engine throttle shutdown solenoid IAW WP 0026 00.</p>

Table 1. Troubleshooting Procedure for Large Capacity Field Heater (LCFH).

MALFUNCTION	TEST OR INSPECTION	CORRECTIVE ACTION
32. Heater starts, shuts down, displays error code: H124 but engine continues to run	Step 1. This error code indicates that the alternator tachometer signal is present before engine start. Turn power switch to OFF. Shut engine down as described in procedure 30 of this work package. Check the engine throttle shutdown cable and ensure that it is not sticking.	Step 1. Lubricate the engine throttle shutdown cable IAW WP 0026 00 and ensure that it is not sticking. Step 2. Replace a defective engine throttle shutdown cable IAW WP 0026 00. Step 3. Replace a defective engine throttle shutdown solenoid IAW WP 0026 00.
33. Heater starts, shuts down, and displays error code: H212	Step 1. This error code indicates that an over current situation exists in the combustion fan. Turn power switch to OFF. Check the burner combustion fan motor shaft and determine if it is stalled or jammed. Step 2. Check the burner combustion fan wiring harness and determine if the wiring harness to the fan has been shorted to ground. Step 3. Determine if the burner combustion fan is defective.	Step 1. Secure the burner combustion fan to correct a stalled or jammed motor shaft. Step 2. Repair or replace a shorted burner combustion fan wiring harness. Step 3. Replace a defective burner combustion fan IAW WP 0049 00.
34. Heater starts, shuts down, and displays error code: H321	Step 1. This error code indicates that an open circuit has been detected at the carbon monoxide inlet air sensor. Turn power switch to OFF. Check cabinet mounted carbon monoxide detector to determine if the wire harness is loose or disconnected. Step 2. Test cabinet mounted carbon monoxide detector IAW WP 0025 00 to determine if it is operating correctly.	Step 1. Secure a loose or disconnected wire harness connector on cabinet mounted carbon monoxide detector IAW WP 0025 00. Step 2. Replace a defective cabinet mounted carbon monoxide detector IAW WP 0025 00.
35. Heater starts, shuts down, and displays error code: H322	Step 1. This error code indicates that a short circuit has been detected at the carbon monoxide inlet air sensor. Turn power switch to OFF. Check cabinet mounted carbon monoxide detector to determine if any of the wires are shorted to one another or to ground. Step 2. Test cabinet mounted carbon monoxide detector to determine if it is operating correctly.	Step 1. Repair any shorted wires on carbon monoxide detector IAW WP 0025 00. Step 2. Replace a defective cabinet mounted carbon monoxide detector IAW WP 0025 00.
36. Heater starts, shuts down,	Step 1. This error code indicates that	Step 1. Secure any loose or

Table 1. Troubleshooting Procedure for Large Capacity Field Heater (LCFH).

MALFUNCTION	TEST OR INSPECTION	CORRECTIVE ACTION
and displays error code: H331	<p>an open circuit has been detected at the carbon monoxide sensor located in the operator control box. Turn power switch to OFF. Check operator control box mounted carbon monoxide detector to determine if any of the wires are loose or disconnected.</p> <p>Step 2. Test operator control box mounted carbon monoxide detector to determine if it is operating correctly.</p>	<p>disconnected wires on carbon monoxide detector IAW WP 0065 00.</p> <p>Step 2. Replace a defective operator control box mounted carbon monoxide detector IAW WP 0065 00.</p>
37. Heater starts, shuts down, and displays error code: H332	<p>Step 1. This error code indicates that a short circuit has been detected at the carbon monoxide sensor on the operator control box. Turn power switch to OFF. Check operator control box mounted carbon monoxide detector to determine if any of the wires are shorted to one another or to ground.</p> <p>Step 2. Test operator control box mounted carbon monoxide detector to determine if it is operating correctly.</p>	<p>Step 1. Repair any shorted wires on carbon monoxide detector IAW WP 0065 00.</p> <p>Step 2. Replace a defective operator control box mounted carbon monoxide detector IAW WP 0065 00.</p>
38. Heater starts, shuts down, and displays error code: H521	<p>Step 1. This error code indicates that an open circuit has been detected in the fuel pump circuit. Turn power switch to OFF. Check fuel pump wiring harness to determine if any of the wires are loose or disconnected.</p> <p>Step 2. Determine if fuel pump is operating correctly.</p>	<p>Step 1. Secure any loose or disconnected wires on fuel pump wiring harness IAW 0028 00.</p> <p>Step 2. Replace a defective fuel pump IAW WP 0028 00.</p>
39. Heater starts, shuts down, and displays error code: H522	<p>Step 1. This error code indicates that a short circuit has been detected in the fuel pump circuit. Turn power switch to OFF. Check fuel pump wiring harness to determine if any of the wires are shorted to ground or to one another.</p> <p>Step 2. Determine if fuel pump is operating correctly.</p>	<p>Step 1. Repair any shorted wires on fuel pump wiring harness IAW WP 0028 00.</p> <p>Step 2. Replace a defective fuel pump IAW WP 0028 00.</p>

Table 1. Troubleshooting Procedure for Large Capacity Field Heater (LCFH).

MALFUNCTION	TEST OR INSPECTION	CORRECTIVE ACTION
40. Heater starts, shuts down, and displays error code: H531	<p>Step 1. This error code indicates that diesel oil pressure has been detected before engine start. Turn power switch to OFF. Check oil pressure switch SW2 wiring harness and determine if any wires are loose or disconnected.</p> <p>Step 2. Determine if the diesel engine is still running from previous use.</p> <p>Step 3. Test pressure switch to determine if it is defective.</p>	<p>Step 1. Repair any loose or disconnected wires.</p> <p>Step 2. Ensure that diesel engine has shut down from previous use. Check engine throttle shutdown cable and make sure it is not sticking.</p> <p>Step 3. Replace a defective engine oil pressure switch SW2.</p>
41. Heater starts, shuts down, and displays error code: H541	<p>Step 1. This error code indicates that an open circuit has been detected at the diesel engine pre-heat relay driver K1. Turn power switch to OFF. Check K1 relay coil wire (see WP 0062 for location) and ensure that it is not loose or disconnected.</p> <p>Step 2. Test engine pre-heat relay K1 and determine if it is defective.</p>	<p>Step 1. Secure any loose or disconnected K1 relay coil wire.</p> <p>Step 2. Replace a defective K1 engine pre-heat relay.</p>
42. Heater starts, shuts down, and displays error code: H542	<p>Step 1. This error code indicates that a short circuit has been detected at the diesel engine pre-heat relay driver K1. Turn power switch to OFF. Check K1 relay coil wire (see WP 0062 00 for location) and ensure that it is not shorted.</p> <p>Step 2. Test engine pre-heat relay K1 and determine if it is defective.</p>	<p>Step 1. Repair a shorted K1 relay coil wire.</p> <p>Step 2. Replace a defective K1 engine pre-heat relay.</p>
43. Heater starts, shuts down, and displays error code: H551	<p>Step 1. This error code indicates that an open circuit has been detected at the diesel engine starter relay driver. This is caused by a defective main control board.</p>	<p>Step 1. Turn power switch to OFF. Replace a defective main control board IAW WP 0063 00.</p>
44. Heater starts, shuts down, and displays error code: H552	<p>Step 1. This error code indicates that a short circuit has been detected at the diesel engine starter relay driver. This is caused by a defective main control board.</p>	<p>Step 1. Turn power switch to OFF. Replace a defective main control board IAW WP 0063 00.</p>

Table 1. Troubleshooting Procedure for Large Capacity Field Heater (LCFH).

MALFUNCTION	TEST OR INSPECTION	CORRECTIVE ACTION
45. Heater starts, shuts down, and displays error code: H562 but engine continues to run.	<p>Step 1. This error code indicates that a short circuit has been detected at the diesel engine throttle stop solenoid relay driver K2 located in the relay box assembly (see WP 0062 00 for location). Shut engine down as described in procedure 30 of this work package. Remove relay control box and check K2 relay coil wire to ensure that it is not shorted to ground.</p> <p>Step 2. Test engine throttle stop solenoid relay driver K2 and determine if it is defective.</p>	<p>Step 1. Repair a shorted K2 relay coil wire.</p> <p>Step 2. Replace a defective engine throttle stop solenoid relay driver K2.</p>
46. Heater starts, shuts down, and displays error code: H611	<p>Step 1. This error code indicates that an open circuit has been detected at fuel solenoid valve FS1 (controls burner on/off). Turn power switch to OFF. Check wire on fuel solenoid valve FS1 and ensure that it is not loose or disconnected.</p>	<p>Step 1. Secure a loose or disconnected wire to the fuel solenoid valve FS1.</p> <p>Step 2. Replace a defective FS1 fuel solenoid valve IAW WP 0031 00.</p>
47. Heater starts, shuts down, and displays error code: H612	<p>Step 1. This error code indicates that a short circuit has been detected at fuel solenoid valve FS1 (controls burner on/off). Turn power switch to OFF. Check wire on fuel solenoid valve FS1 and ensure that it is not shorted to ground.</p>	<p>Step 1. Repair a shorted wire to the fuel solenoid valve FS1.</p> <p>Step 2. Replace a defective FS1 fuel solenoid valve IAW WP 0031 00.</p>
48. Heater starts, shuts down, and displays error code: H621	<p>Step 1. This error code indicates that an open circuit has been detected at fuel solenoid valve FS2 (controls burner high fire/low fire). Turn power switch to OFF. Check wire on fuel solenoid valve FS2 and ensure that it is not loose or disconnected.</p>	<p>Step 1. Secure a loose or disconnected wire to the fuel solenoid valve FS2.</p> <p>Step 2. Replace a defective FS2 fuel solenoid valve IAW WP 0032 00.</p>
49. Heater starts, shuts down, and displays error code: H622	<p>Step 1. This error code indicates that a short circuit has been detected at fuel solenoid valve FS2 (controls burner high fire/low fire). Turn power switch to OFF. Check wire on fuel solenoid valve FS2 and ensure that it is not shorted to ground.</p>	<p>Step 1. Repair a shorted wire to the fuel solenoid valve FS2.</p> <p>Step 2. Replace a defective FS2 fuel solenoid valve IAW WP 0032 00.</p>

Table 1. Troubleshooting Procedure for Large Capacity Field Heater (LCFH).

MALFUNCTION	TEST OR INSPECTION	CORRECTIVE ACTION
50. Heater starts, shuts down, and displays error code: H631	Step 1. This error code indicates that an open circuit has been detected at fuel solenoid valve FS3 (controls internal/external fuel supply). Turn power switch to OFF. Check wire on fuel solenoid valve FS3 and ensure that it is not loose or disconnected.	Step 1. Secure a loose or disconnected wire to the fuel solenoid valve FS3. Step 2. Replace a defective FS3 fuel solenoid valve IAW WP 0029 00.
51. Heater starts, shuts down, and displays error code: H632	Step 1. This error code indicates that a short circuit has been detected at fuel solenoid valve FS3 (controls internal/external fuel supply). Turn power switch to OFF. Check wire on fuel solenoid valve FS3 and ensure that it is not shorted to ground.	Step 1. Repair a shorted wire to the fuel solenoid valve FS3. Step 2. Replace a defective FS3 fuel solenoid valve IAW WP 0029 00.
52. Heater starts, shuts down, and displays error code: H251	Step 1. This error code indicates that an open circuit has been detected at spark ignition transformer relay T1. This is caused by a defective main control board.	Step 1. Replace a defective main control board IAW WP 0063 00.
53. Heater starts, shuts down, and displays error code: H252	Step 1. This error code indicates that a short circuit has been detected at spark ignition transformer relay T1. This is caused by a defective main control board.	Step 1. Turn power switch to OFF. Replace a defective main control board IAW WP 0063 00.
54. Heater starts, shuts down, and displays error code: H801	Step 1. This error code indicates that there has been a watchdog (COP) timeout indicating a loss of software control for greater than 1 second.	Step 1. Cycle the on/off switch on the operator control panel to determine if problem has been resolved. Step 2. Turn power switch to OFF. Replace a defective main control board IAW WP 0063 00.
55. Heater starts, shuts down, and displays fault code: H311	Step 1. This fault code indicates that the LCFH has detected carbon monoxide at the operator control panel. Evacuate any personnel that may be in the shelter and look for signs of carbon monoxide poisoning. Check the flexible air inlet duct and ensure that it does not have any rips, tears, or other damage that would allow combustion exhaust to enter the inlet air flow. Step 2. Check and ensure that the flexible inlet air duct is securely attached to the air inlet duct adapter on the LCFH. Step 3. Ensure that the shelter opening is not downwind of the LCFH is such a	Step 1. Repair any tears in the flexible air inlet duct with duct tape. Replace flexible air duct if damage cannot be completely repaired with duct tape. Step 2. Attach flexible air inlet duct to air inlet duct adapter lock in place securely. Step 3. Move LCFH so that combustion exhaust does not enter

Table 1. Troubleshooting Procedure for Large Capacity Field Heater (LCFH).

MALFUNCTION	TEST OR INSPECTION	CORRECTIVE ACTION
<p>56. Heater starts, shuts down, and displays fault code: H312</p>	<p>way as to allow combustion exhaust to enter the shelter.</p> <p>Step 4. Determine if there are any other sources of carbon monoxide (vehicles, generators, etc.) that may be running nearby. Determine if the combustion exhaust from those sources may be getting into the LCFH airflow.</p> <p>Step 1. This fault code indicates that the LCFH has detected carbon monoxide at the cabinet mounted carbon monoxide detector. Evacuate any personnel that may be in the shelter and look for signs of carbon monoxide poisoning. Check the flexible air inlet duct and ensure that it does not have any rips, tears, or other damage that would allow combustion exhaust to enter the inlet air flow.</p> <p>Step 2. Check and ensure that the flexible inlet air duct is securely attached to the air inlet duct adapter on the LCFH.</p> <p>Step 3. Ensure that the shelter opening is not downwind of the LCFH is such a way as to allow combustion exhaust to enter the shelter.</p> <p>Step 4. Determine if there are any other sources of carbon monoxide (vehicles, generators, etc.) that may be running nearby. Determine if the combustion exhaust from those sources may be getting into the LCFH airflow.</p>	<p>shelter during LCFH operation.</p> <p>Step 4. Move sources of carbon monoxide a safe distance away from the shelter and the LCFH.</p> <p>Step 5. If problem reoccurs and there is no evidence of high carbon monoxide levels, replace the operator control panel carbon monoxide detector.</p> <p>Step 1. Repair any tears in the flexible air inlet duct with duct tape. Replace flexible air duct if damage cannot be completely repaired with duct tape.</p> <p>Step 2. Re-attach flexible air inlet duct to air inlet duct adapter lock in place securely.</p> <p>Step 3. Move LCFH so that combustion exhaust does not enter shelter during LCFH operation.</p> <p>Step 4. Restart LCFH. If fault reoccurs, stop use of LCFH and notify Unit Maintenance.</p> <p>Step 5. Step 5. If problem reoccurs and there is no evidence of high carbon monoxide levels, replace the cabinet mounted carbon monoxide detector.</p>
<p>57. Fuel leak is observed in the heater.</p>	<p>Step 1. Determine the area where the leak is originating. In all likelihood, this will be in the area of the fuel panel assembly, the burner valve assembly, or the fuel tank assembly.</p>	<p>Step 1. Shut down heater. If fuel leak has been detected in a flare fitting, re-tighten. If fitting continues to leak, inspect for dirt or debris on the flare "male" and "female" areas and clean if needed. If leak persists, replace both hose and component.</p> <p>Step 2. For fuel leaks in hoses using barb fittings and screw hose clamps,</p>

Table 1. Troubleshooting Procedure for Large Capacity Field Heater (LCFH).

MALFUNCTION	TEST OR INSPECTION	CORRECTIVE ACTION
<p>58. Heater starts, shuts down, and displays fault code: H431</p>	<p>Step 1. This error code indicates that an open circuit has been detected at the outlet temperature sensor RTD1.</p>	<p>ensure that the hose is fully inserted onto the hose barb and then re-tighten the clamp.</p> <p>Step 3. If a leak is found anywhere in the length of the hose, replace entire hose.</p> <p>Step 1. Repair the open wire to the outlet temperature sensor RTD1.</p> <p>Step 2. Replace a defective RTD1 outlet temperature sensor IAW WP 0055 00.</p>
<p>59. Heater starts, shuts down, and displays fault code: H432</p>	<p>Step 1. This error code indicates that a shorted circuit has been detected at the outlet temperature sensor RTD1.</p>	<p>Step 1. Repair the shorted wire to the outlet temperature sensor RTD1.</p> <p>Step 2. Replace a defective RTD1 outlet temperature sensor IAW WP 0055 00.</p>
<p>60. The operator control panel is off and the LED screen is blank, but the engine continues to run.</p>	<p>The diesel engine does not require electrical power to operate, though electrical power is needed to shut it down. This malfunction could be the result of the following:</p> <p>Step 1. The stop solenoid is faulty. This malfunction will most likely be accompanied by error codes H123, H124, H561, or H562</p> <p>Step 2. The charging system has malfunctioned and there is insufficient power to energize the stop solenoid.</p> <p>Step 3. The main printed circuit board, operator control box, or associated cables have malfunctioned and are not energizing the stop solenoid. Ensure that the main printed circuit board has approximately 24 VDC at the power lead located on the bottom of the box.</p> <p>Step 4. The system batteries are in a low charge state and are being supplemented with a NATO slave power, which is removed before the battery charge is sufficient to sustain operation.</p>	<p>Perform emergency engine shutdown procedures IAW WP 0006 01.</p> <p>Step 1. Replace solenoid stop switch IAW WP 0027 00.</p> <p>Step 2. Refer to troubleshooting step 19 of this WP.</p> <p>Step 3. Refer to troubleshooting step 26 of this WP.</p> <p>Step 4. Replace main printed circuit board.</p> <p>Step 5. Restart using external slave power. Allow engine to operate for 15 minutes before disconnecting external power.</p> <p>Step 6. Check battery voltage. If battery voltage is not between 15</p>

		and 26 VDC at the slave connector, the charging system is malfunctioning. Refer to troubleshooting step 19 of this WP.
--	--	--

END OF WORK PACKAGE

CHAPTER 6
FIELD (UNIT) MAINTENANCE INSTRUCTIONS
LARGE CAPACITY FIELD HEATER (LCFH)

**OPERATOR, FIELD AND SUSTAINMENT MAINTENANCE
LARGE CAPACITY FIELD HEATER (LCFH)
UNIT PREVENTIVE MAINTENANCE CHECKS AND SERVICES INTRODUCTION**

INTRODUCTION

Preventive Maintenance Checks and Services (PMCS) are performed to keep the Large Capacity Field Heater (LCFH) in good operating condition and ready for its primary mission. The checks are used to find, correct, and report problems. PMCS is performed every day the Large Capacity Field Heater (LCFH) is in operation, and is done according to the PMCS table provided. Pay attention to **WARNING**, **CAUTION**, and **NOTE** statements. A **WARNING** indicates that someone could be hurt or killed. A **CAUTION** indicates that equipment could be damaged. A **NOTE** may make your maintenance or repair task easier.

Be sure to perform scheduled PMCS. Always perform PMCS in the same order so it becomes habit. With practice, you will quickly recognize problems with the equipment.

Use DA Form 2404, Equipment Inspection and Maintenance Worksheet, to record any discovered faults. Do not record faults that you fix!

PMCS PROCEDURES

Table 1 lists inspections and care required to keep your equipment in good operating condition. It is arranged so that you can perform before operation checks as you walk around the equipment.

Explanation of Table 1 columns**Item Number**

Indicates the reference number. When completing DA Form 2404, Equipment Inspection and Maintenance Worksheet, include the item number for the item to check/service indicating a fault. Item numbers appear in the order you must perform the checks/services listed.

Interval

Indicates when you must perform the procedure in the procedure column.

- before** - perform before equipment operation
- during** - perform during equipment operation
- after** - perform after equipment has been operated
- weekly** - perform every week
- monthly** - perform each month
- hours** - perform at the noted hourly interval

Item to Check/Service

Indicates the item to be checked or serviced.

Procedure

Indicates the procedure you must perform on the item listed in Item to Check/Service column. You must perform the procedure at the time specified in the Interval column. If you are not authorized to perform the maintenance task indicated, notify direct support maintenance.

Not Fully Mission Capable If:

Indicates faults which will prevent your equipment from performing its primary mission. If you perform procedures listed in Procedure column which show faults listed in this column, do not operate the equipment. Follow standard procedures for maintaining the equipment or reporting equipment failure.

Other special entries

Observe all special information and notes that appear in Table 1.

When a check/service procedure is required for both weekly and before intervals, it is not necessary to perform the procedure twice if the equipment is operated during the weekly period.

COMMON CHECKS AND CLEANING**Cleaning**

Always keep the equipment clean. Remove dirt, sand, and debris from all circuit breakers and hose connections.

Bolts, nuts, and screws

Check them for obvious looseness, missing, bent, or broken condition on equipment. If you find a bolt, nut, or screw you think is loose, tighten it or report it to your supervisor.

Hoses

Look for wear, damage, and leaks. Ensure clamps are tight. Wet spots show leaks, but a stain around a fitting or connector can also mean a leak. If a leak comes from a loose fitting or coupling, tighten it. If something is broken or worn out, report it to your supervisor.

LEAKAGE DEFINITION FOR PERFORMING PMCS

It is necessary for you to know how fluid leakage affects the status of the equipment. The following are the types/classes of leakage an operator needs to know to be able to determine the status of the water system. Learn these leakage definitions and remember - when in doubt, notify your supervisor.

CAUTION

Equipment operation is allowable with minor leakages (Class I or II). Of course, consideration must be given to fluid capacity in the system, when in doubt, notify your supervisor.

When operating with Class I or II leaks, continue to check fluid levels as required in your PMCS.

Class III leaks should be reported immediately to your supervisor.

Class I - Seepage of fluid (as indicated by wetness or discoloration) not great enough to form drops.

Class II - Leakage of fluid great enough to form drops but not enough to cause drops to drip from item being checked/inspected.

Class III - Leakage of fluid great enough to form drops that fall from items being checked/inspected.

**OPERATOR, FIELD AND SUSTAINMENT MAINTENANCE
LARGE CAPACITY FIELD HEATER (LCFH)
UNIT PREVENTIVE MAINTENANCE CHECKS AND SERVICES**

Table 1. Unit Preventive Maintenance Checks and Services.

ITEM NO.	INTERVAL	LOCATION/ITEM TO CHECK/SERVICE	PROCEDURE	NOT FULLY MISSION CAPABLE IF:
1	250 hours	Engine oil strainer	Remove and clean engine oil strainer (WP 0052 00). Replace as required.	Oil strainer is clogged, dirty, or damaged.
2	250 hours	Engine lubricating oil system	NOTE First oil service occurs between 20 and 50 hours of operation, 250 hour intervals thereafter. Service engine lubricating oil (WP 0046 00).	Engine oil has not been changed.
3	Check every 250 hours; replace at 1000 hours	Burner nozzle and electrodes	Check burner nozzle and electrodes IAW WP 0050 00, adjust if necessary. Replace burner nozzle at 1000 hours (WP 0050 00).	Burner nozzle clogged or electrodes out of adjustment.
4	250 hours	Heat Exchanger	Drain heat exchanger IAW WP 0054.	Heat exchanger retaining fluid.
5	500 hours	Engine air filter	Remove and replace air filter (WP 0046 00).	Air filter is dirty or damaged.
6	500 hours	Diesel engine injection pump	a. Inspect fuel injection pump for damage and evidence of leakage. b. Check area around pump sealing gasket for leaks. Remove and replace gasket as required (refer to Direct Support Maintenance).	Fuel leak of any kind is present.
7	500 hours	Engine intake and exhaust valve clearance	NOTE First valve clearance check occurs between 20 and 50 hours of operation, 500 hour intervals thereafter. Adjust valve clearance of intake and exhaust valve seats (WP 0041 00).	Valves are not properly adjusted, causing improper engine operation.

Table 1. Unit Preventive Maintenance Checks and Services.

ITEM NO.	INTERVAL	LOCATION/ITEM TO CHECK/SERVICE	PROCEDURE	NOT FULLY MISSION CAPABLE IF:
8	500 hours	Diesel engine injection nozzle	Inspect fuel injector nozzle, replace as required (WP 0043 00).	Fuel injector nozzle clogged or otherwise not functional.
9	1000 hours or as required	Fuel filter	Replace fuel filter per schedule (WP 0027 00) or sooner as conditions dictate.	Fuel filter clogged.
10	1000 hours	Alternator drive belt	Inspect drive belt and adjust. Replace if necessary (WP 0039 00).	Belt worn, or damaged. Belt in need of tensioning.
11	1000 hours	Burner cone	Inspect and service burner cone (WP 0051 00)	Excessive carbon or debris in burner cone.
12	1000 hours	Flexible Coupling	Inspect flexible coupling IAW WP 0033 00.	Flexible coupling slipping causing system burner fuel pressure to fall below 200 psi.
13	1500 hours	Alternator drive belt	Replace drive belt (WP 0039 00).	Belt worn or damaged.
14	Once per year	Cabinet mounted carbon monoxide detector	Test carbon monoxide (CO) detector in heater cabinet, replace if necessary (WP 0025 00).	CO detector does not operate.
15	Once per year	Heat exchanger outlet temperature sensor	Test heat exchanger outlet temperature sensor (WP 0055 00)	Sensor damaged or tests as open circuit when heater not operating.
16	Once per year	Tires	Inspect tires and replace wheel retraction assembly if necessary (WP 0014 00).	Tires damaged.
17	Once per year	Fuel Tank	Drain accumulated water from fuel tank (WP 0034 00).	Water in fuel tank
18	Every 5 years	Operator Control Box and Cabinet Mounted Carbon Monoxide Detectors	Replace carbon monoxide detector installed in operator control box IAW WP 0065. Replace carbon monoxide detector installed in cabinet IAW WP 0025.	This is a mandatory replacement.

LUBRICATION INSTRUCTIONS

GENERAL

These lubrication instructions are for unit level maintenance personnel. Lube intervals (on-condition or hard time) are based on normal operation. Lube more during constant use, and less during inactive periods. Use correct grade of lubricant for seasonal temperature expected.

CAUTION

Always wipe clean oil filler components before starting your lube service. Use correct type or grade of oil. Overfilling will cause spillage and harm engine components.

The engine oil filter shall be changed as applicable when:
 It is known to be contaminated or clogged.
 The prescribed hard time interval has arrived.

This heater is not enrolled in the Army Oil Analysis Program (AOAP). Hard time service intervals apply.

For equipment under manufacturer’s warranty, hard time oil service intervals shall be followed. Intervals shall be shortened if lubricants are known to be contaminated or if operation is under adverse conditions (such as longer than usual operating hours, extended idling periods, or extreme dust).

Table 2. Lubricant Table for Large Capacity Field Heater (LCFH)

Lubricant Specification	Temperature Range	System Capacity	Change Interval	Man-hours
MIL-L-46167 Arctic Engine Oil	-50°C to 0°C	1.2 US quarts. (1.1 liters.)	250 hours	0.25
5W30 A.P.I. Engine Service Classification CC, CD, or CF	-30°C to 10°C	1.2 US quarts. (1.1 liters.)	250 hours	0.25
10W30 A.P.I. Engine Service Classification CC, CD, or CF	-20°C to 30°C	1.2 US quarts. (1.1 liters.)	250 hours	0.25
20W40 A.P.I. Engine Service Classification CC, CD, or CF	-10°C to 40°C	1.2 US quarts. (1.1 liters.)	250 hours	0.25

DRAIN AND SERVICE ENGINE OIL AND FILTER AS FOLLOWS:**WARNING**

Allow the engine to cool for approximately 30 minutes before changing oil. Engine oil is hot and presents a burn hazard. Coming in contact with hot engine oil may cause burns and severe injury.

NOTE

The engine must be standing level and be switched off. Be sure to change the oil when the engine is warm (not hot) so that the engine oil remains easy to drain. Be sure to collect the used oil and dispose of in accordance with Unit SOP and local regulations.

1. Remove oil drain hose **(1)** from spring clamp **(2)**. Loosen and remove oil drain plug **(3)** and allow the oil to drain out into an approved container.
2. Clean the oil drain plug **(2)** and reinstall on oil drain hose **(1)**.
3. Return oil drain hose **(1)** to spring clamp **(2)**.

CAUTION

The type and viscosity of engine oil used for daily operations is determined by the current local ambient operating temperature/climate range where the LCFH is being used. Use only the engine oils that meet the quality and temperature specifications listed in Table 2 above. Using oil other than that listed above may result in difficult starting and/or damage to the diesel engine.

4. Add 1.2 US quarts (1.1 liters) of appropriate engine lubrication oil (Table 2).

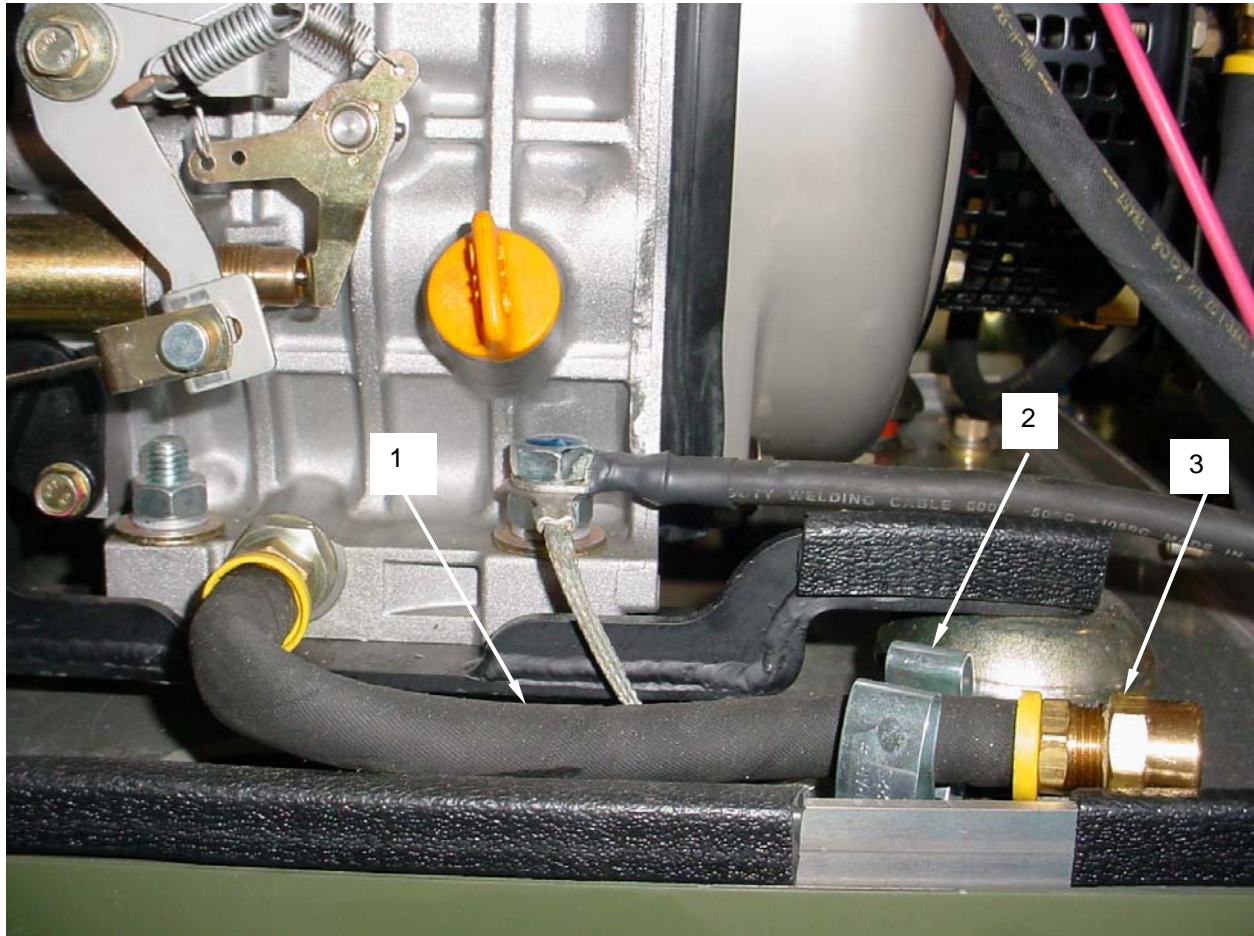

END OF WORK PACKAGE

FIELD (UNIT) MAINTENANCE**LARGE CAPACITY FIELD HEATER**

NSN 4520-01-500-1534

FIELD (UNIT) MAINTENANCE INTRODUCTION

GENERAL

The procedures in this section have been arranged in order in which the items appear in the Unit (O) Maintenance level column on the Maintenance Allocation Chart (MAC) which is provided in WP 0092. Step by step procedures have been provided for all actions authorized to be performed by the Unit in Chapter 6.

WIRING

General. Preferred repair methods consist of replacing wires, terminals, connectors, etc. , rather than splicing wires, bending ends to form terminals, and other makeshift procedures, although the latter may be appropriate for emergency field repairs.

Soldering Connections. Wire connections must be made mechanically sound before they are soldered. Solder alone does not provide sufficient strength to prevent breakage. Joining surfaces of connections to be soldered must be clean and bright. If a separate flux is used, it should be rosin base flux and should be brushed onto the joint before soldering. If a flux-core solder is used, it should be a rosin core electrical solder. If uncored solder is used, it should be a lead-tin solder. Wires should always be heated to the point at which the solder will melt completely and flow into all parts of the joint. Excessive build up of solder "gobs" on the joint should be avoided or removed.

Insulating Joints. The preferred method of insulating electrical joints is by the use of heat-shrink tubing. To apply, cut a piece of heat-shrink tubing of suitable diameter to a one-inch length for covering joints at terminals or connectors, or to a length about 1/2 inch (1.3 cm) longer than the joint to be insulated, and slide the tubing over the wire before making the joint. After the joint is made, slide the tubing so that it covers the joint, and shrink in place with moderate heat.

Splicing Wires. To repair broken or cut wires that are otherwise sound, the mating ends can be stripped and spliced. A commercial butt splice can be crimped onto the ends to join them, or a 'Western Union' wire splice can be made. The latter is made by stripping 1/4-1/2 inch (6.5-12.7 mm) of insulation from the wire ends, holding the ends parallel and facing opposite directions, then twisting each end around the other wire at least three turns. Solder and apply insulation as described above.

Crimping Terminals. To install a terminal on the end of a wire, strip 1/4-1/2 inch (6.5 12.7 mm) of insulation from the end of the wire, apply a one-inch piece of heat-shrinking tubing (if the terminals are of the uninsulated type) and insert wire end into the shank of the terminal. Crimp the shank, and install heat-shrink tubing, if necessary.

CLEANING AND INSPECTION OF ANTIFRICTION BEARINGS

Refer to TM 9-214, Inspection, Care, and Maintenance of Antifriction Bearings.

CLEANING AND INSPECTION OF MECHANICAL PARTS**WARNING**

Drycleaning solvent is flammable and toxic to eyes, skin, and respiratory tract. Skin/eye protection is required. Avoid repeated/prolonged contact. Use only in well ventilated areas. Keep away from open flames or other sources of ignition.

Compressed air used for cleaning purposes will not exceed 30 psi (kPa). Use only with effective personal protective equipment.

Clean metal parts in drycleaning solvent. Thoroughly dry the parts with compressed air, observing all safety precautions.

Fibrous or rubber parts can generally be cleaned with warm, soapy water and dried with compressed air.

Inspect metal parts for cracks, breaks, bends, worn edges, and rough bearing surfaces. Damage that alters the part or its function is cause for replacement of that part.

GENERAL REPAIR

Repair the unit to normal operating condition by replacing or repairing a defective component and/or by needed adjustments.

Cleaning and lubrication is sometimes all that is needed to return an item to operating condition.

Remove and replace only those items necessary to make repairs. After replacing the defective components, ensure that the unit operates correctly.

To paint metal, sand bare metal areas with sandpaper and refinish with primer and olive drab paint. Refer to TM 43-0139 for proper painting instructions. Allow paint to dry between coats.

END OF WORK PACKAGE

FIELD (UNIT) MAINTENANCE**LARGE CAPACITY FIELD HEATER**

NSN 4520-01-500-1534

**CABINET ASSEMBLY
INSPECT, SERVICE**

INITIAL SETUP:**Tools**

None required

Personnel Required

MOS 63J or 52C

Materials/Parts

Silicone Lubricant (Item 3, WP 0119 00)

Equipment Condition

Heater shut down and cool (WP 0005 00)

Main battery switch OFF and handle removed

INSPECT

Inspect the cabinet and ensure that there are no dents, cuts, or other damage that could prevent the heater from operating safely.

SERVICE

1. Lubricate slide portion **(1)** and pivot **(2)** of all locking fasteners **(3)** with silicone lubricant.
2. Lubricate all door latches **(4)** and hinges **(5)** and with silicone lubricant.

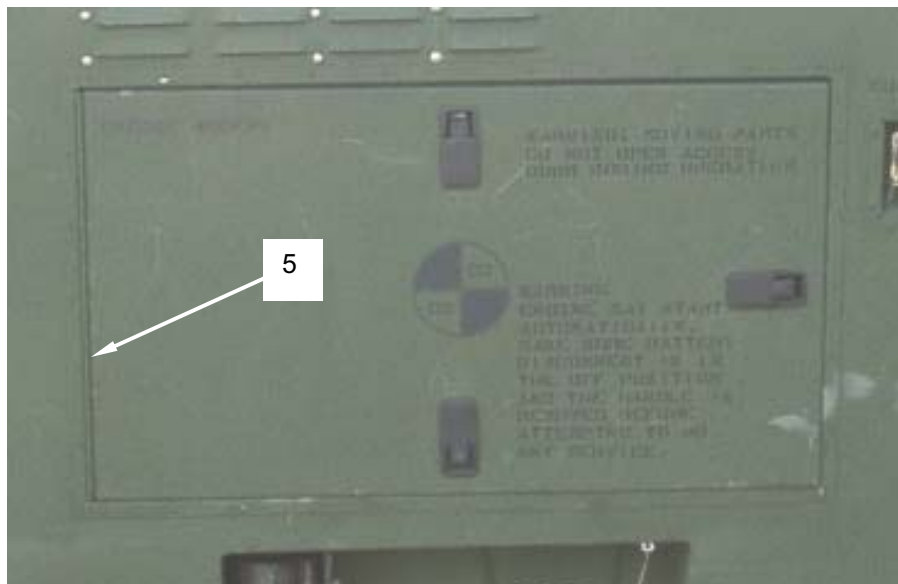
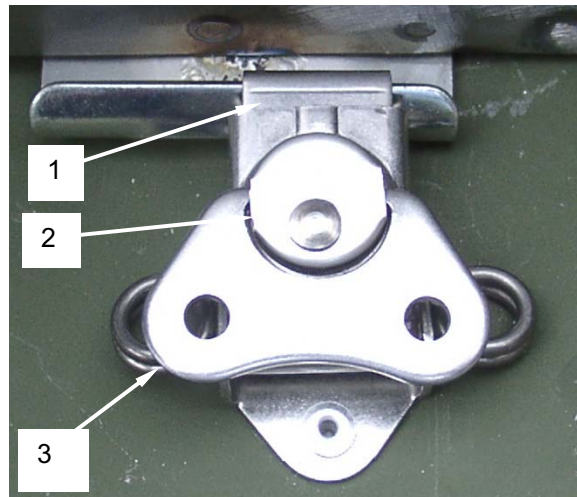

END OF WORK PACKAGE

FIELD (UNIT) MAINTENANCE

LARGE CAPACITY FIELD HEATER

NSN 4520-01-500-1534

SHEET SOUND INSTALLATION
INSPECT, REPLACE

INITIAL SETUP:

Tools

Tool Kit, General Mechanics (Item 1, WP 0092 00)

Heat Gun, Electric (Item 18, WP 0092 00)

Personnel Required

MOS 63J or 52C

Materials/Parts

Solvent, degreasing (Item 24, WP 0119 00)

Rags, Wiping (Item 4, WP 0119 00)

Equipment Condition

Heater shut down and cool. (WP 0005 00)

Main battery switch OFF and handle removed.

INSPECT

NOTE

Sound insulation is installed on the divider bulkhead, fan bulkhead, engine bay door, engine access cover, and selected locations of the fuel/burner end wall. These locations have a combination of foam insulation bonded to a 1/8 inch sound dampening material. The fan housing, heat exchanger sidewalls, top cover, and operator control box tray have only the 1/8 inch dampening material applied.

Inspect all sound insulation for tears, cracks, delamination, or other damage that would prevent the sound insulation from adequate restricting sound levels in the operating environment. Replace any damaged sound insulation.

REPLACE

NOTE

All sound insulation sections are pre-cut to size. Foam insulation is 1 or 2 inches thick depending on location.

1. To replace a section of damaged 1/8 inch sound dampening insulation **(1)**, pry the corner up using a putty knife or similar tool.
2. Set the heat gun to midrange and begin to heat the adhesive that bonds the insulation **(1)** to the cabinet wall **(2)**, prying the insulation from the cabinet wall.
3. Continue until the damaged section of sound insulation is removed.
4. Clean the adhesive residue from the cabinet wall with a rag dampened with solvent.
5. If required for that section, install a new, pre-cut section of 1/8 inch sound dampening insulation by removing the paper backing, exposing the pressure sensitive adhesive backing.

6. Starting at one side, press the adhesive side of the 1/8 inch sound dampening insulation (1) in place. Continue pressing the remainder of the insulation in place.
7. Install a new, pre-cut section of 1 or 2 inch foam sound insulation (3) by removing the paper backing, exposing the pressure sensitive adhesive backing.
8. Starting at one side, press the adhesive side of the 1 or 2 inch sound insulation (3) in place on top of the 1/8 inch sound dampening insulation (1) already in place. Continue to press the remainder of the insulation (3) in position.



END OF WORK PACKAGE

 FIELD (UNIT) MAINTENANCE

LARGE CAPACITY FIELD HEATER

NSN 4520-01-500-1534

 JACK INSTALLATION
 REPLACE

INITIAL SETUP:

Tools
 Tool Kit, General Mechanics (Item 1, WP 0092
 00)
Personnel Required

MOS 63J or 52C

Materials/Parts

None required

Equipment Condition
 Heater shut down and cool. (WP 0005 00)
 Main battery switch OFF and handle removed.

REPLACE

1. If necessary, block the front of the heater to take weight off the jack assembly **(1)**.
2. Remove the bolts, lockwashers, and flat washers securing the heat exchanger top cover **(2)** and the fan top cover **(3)** in order to gain access to the heater interior. Set the covers as well as all bolts, lockwashers, and flat washers aside.
3. Remove the locknut **(4)**, hex head bolt **(5)**, and two flat washers **(6 and 7)**, from each of four locations securing the jack assembly **(1)** to the cabinet **(8)**.
4. Remove the jack assembly **(1)**.
5. Install a new jack assembly by aligning the holes in the mounting flanges **(9)** with the holes in the cabinet **(8)**.
6. Install a flat washer **(6)** and hex head bolt **(5)** through the mounting flange **(9)** and cabinet **(8)** from the outside of the heater. Secure using a flat washer **(7)** and locknut **(4)** on the interior of the heater in four locations. Tighten all fasteners securely.

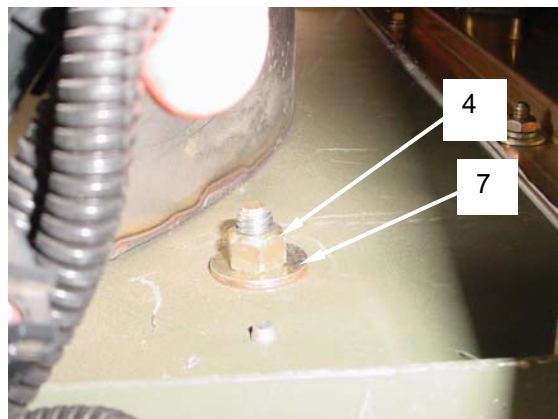
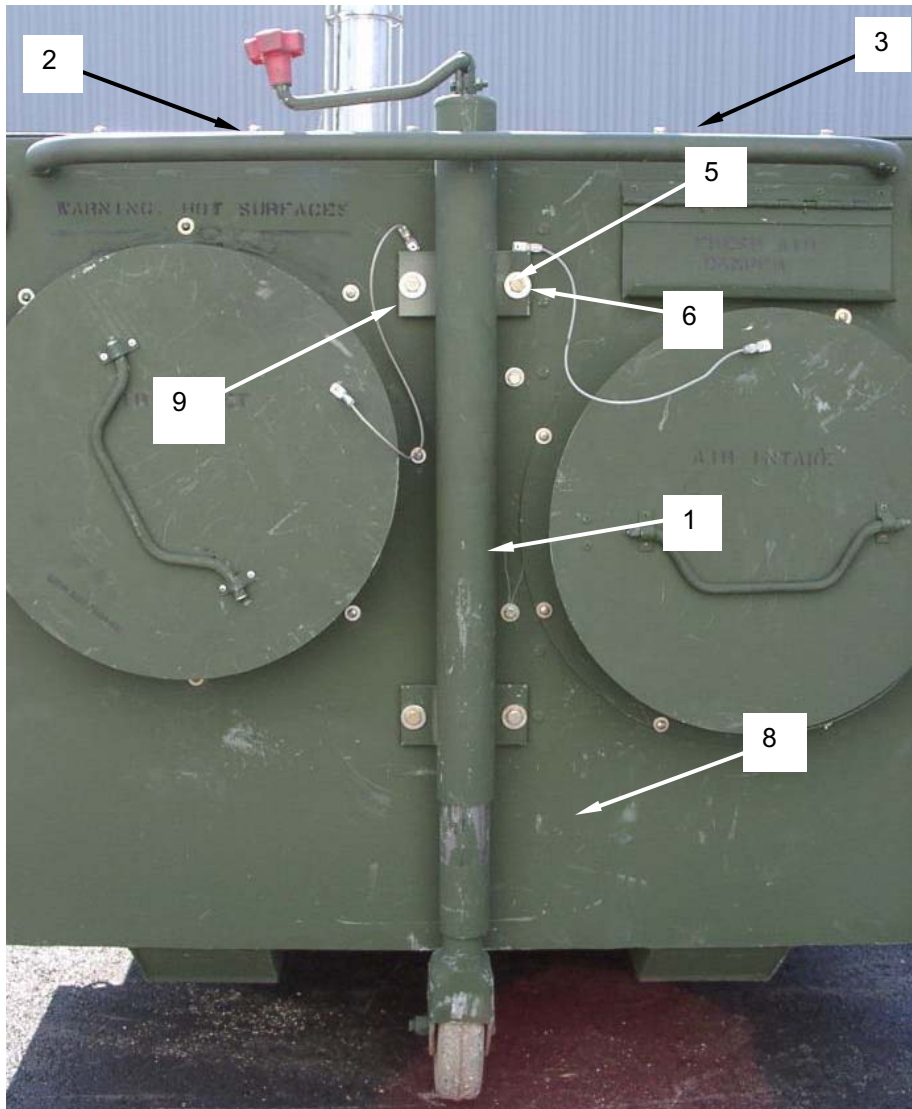

END OF WORK PACKAGE

FIELD (UNIT) MAINTENANCE**LARGE CAPACITY FIELD HEATER****NSN 4520-01-500-1534****DOOR LATCH
SERVICE, REPLACE**

INITIAL SETUP:**Tools**

Tool Kit, General Mechanics (Item 1, WP 0092 00)

Personnel Required

MOS 63J or 52C

Materials/Parts

Lubricant, silicone (Item 3, WP 0119 00)

Equipment ConditionHeater shut down and all advisory lights off.
(WP 0005 00)Main battery switch OFF and handle removed.

SERVICELubricate the pivot portion **(1)** of the various door latches with a silicone lubricant.**REPLACE****CAUTION**

Ensure that the door latch is replaced in the same position as originally installed.

1. Take note of the orientation of the door latch to ensure that it is replaced in the same position as before.
2. Remove the screw **(2)** and bracket **(3)** that secures the door latch **(4)** to the cabinet **(5)**.
3. Remove the door latch **(4)**.
4. Install a new door latch in the same orientation as noted earlier.
5. Align the bracket **(3)** over the hole **(6)** in the door latch and install screw **(2)**. Tighten securely.

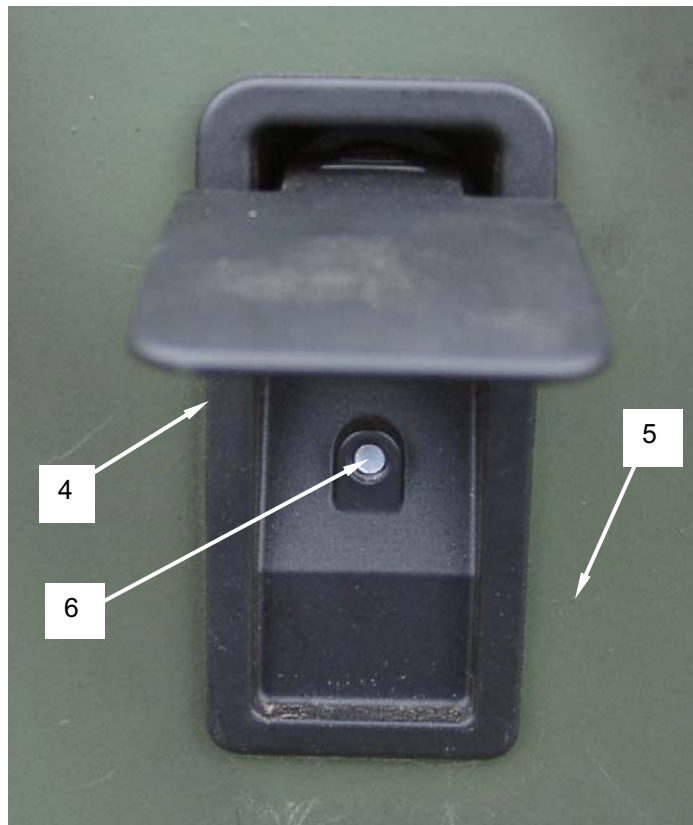
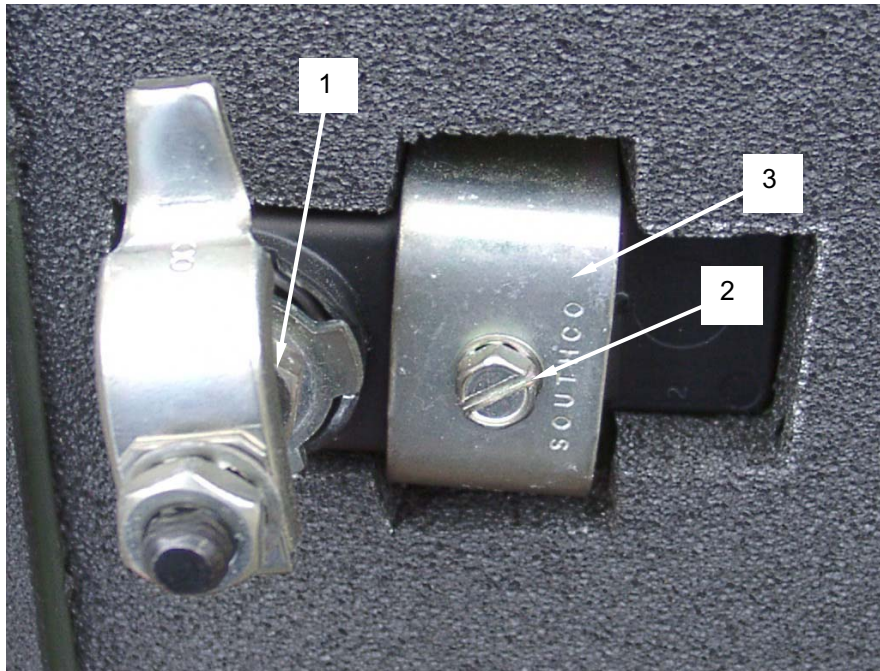

END OF WORK PACKAGE

FIELD (UNIT) MAINTENANCE**LARGE CAPACITY FIELD HEATER**

NSN 4520-01-500-1534

**OPERATOR BOX MOUNTING BRACKET
REPLACE**

INITIAL SETUP:**Tools**

Tool Kit, General Mechanics (Item 1, WP 0092 00)
Riveter, Blind Hand St, Straight Head; for 1/8, 9/64, & 0.188 in Rivet Sizes (Item 10, WP 0092)

Personnel Required

MOS 63J or 52C

Materials/Parts

Rivet, blind (Item 28, WP 0119 00)

Equipment ConditionHeater shut down and cool. (WP 0005 00)

REPLACE (UPPER BRACKET)

1. To replace the upper operator box mounting bracket **(1)**, drill out the rivets **(2)** that secure the bracket with an appropriately sized drill bit that removes the head of the rivet without enlarging the mounting hole.
2. Remove the damaged bracket **(1)**.
3. Install a new bracket **(1)** by aligning the holes in the bracket with the holes in the cabinet **(3)**.
4. Install new rivets **(2)** using a hand riveter.

REPLACE (LOWER BRACKET)

1. To replace the lower locking fastener **(4)**, drill out the rivets **(5)** that secure the fastener **(4)** with an appropriately sized drill bit that removes the head of the rivet without enlarging the mounting hole.
2. Remove the damaged fastener **(4)**.
3. Install a new fastener **(4)** by aligning the holes in the fastener with the holes in the cabinet **(6)**.
4. Install new rivets **(5)** using a hand riveter.

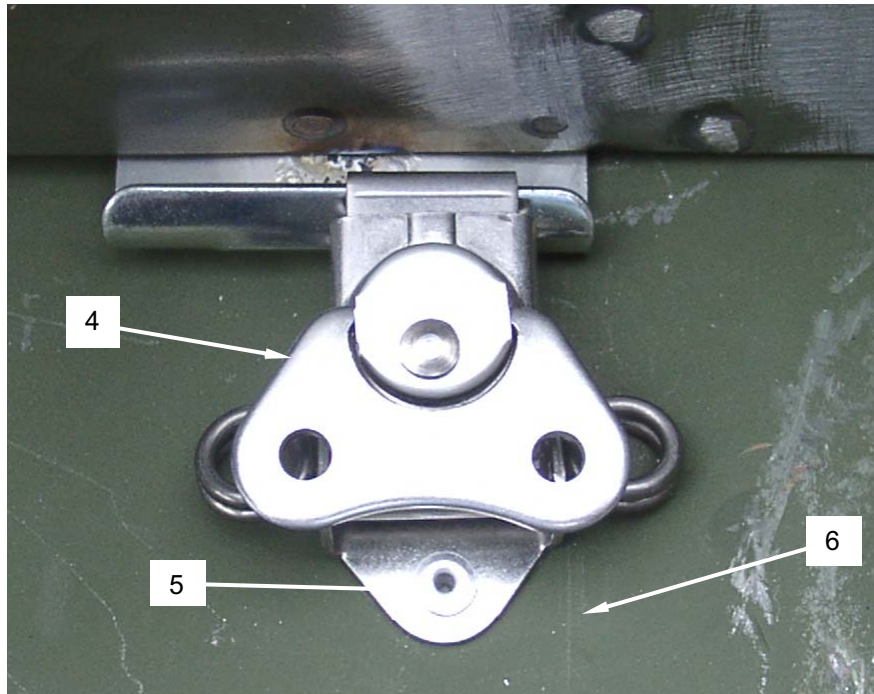
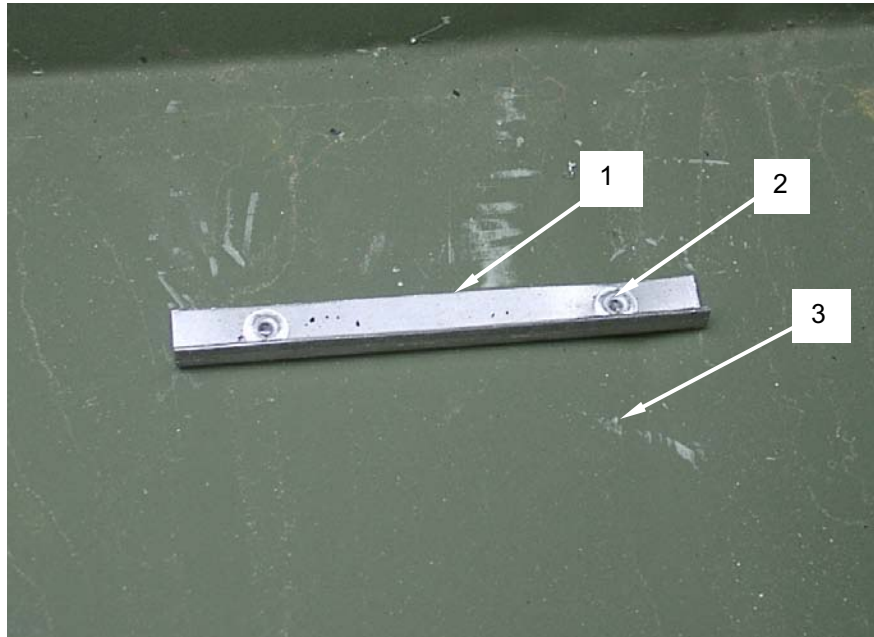

END OF WORK PACKAGE

FIELD (UNIT) MAINTENANCE

LARGE CAPACITY FIELD HEATER

NSN 4520-01-500-1534

CARBON MONOXIDE DETECTOR – CABINET
INSPECT, TEST, REPLACE**INITIAL SETUP:****Tools**

Tool Kit, General Mechanics (Item 2, WP 0092 00)

Personnel Required

MOS 52C or MOS 63J

Materials/Parts

None required.

Equipment ConditionHeater shut down and cool. (WP 0005 00)
Main battery switch in the OFF position and handle removed.**INSPECT****NOTE**

The cabinet mounted carbon monoxide detector must be replaced every 5 years regardless of the results of inspection or test. Refer to the section of this work package entitled REPLACE for complete details on replacement.

1. Remove the eight hex head bolts (1) and washers (2) securing the fan compartment cover (3) to the LCFH cabinet (4).
2. Remove the fan compartment cover (3) to expose the carbon monoxide detector (5).
3. Inspect the carbon monoxide detector (5) enclosure for cracks, punctures, or any other damage that would prevent the detector from operating properly. If damaged, replace the detector as detailed in the section of this work package entitled REPLACE.

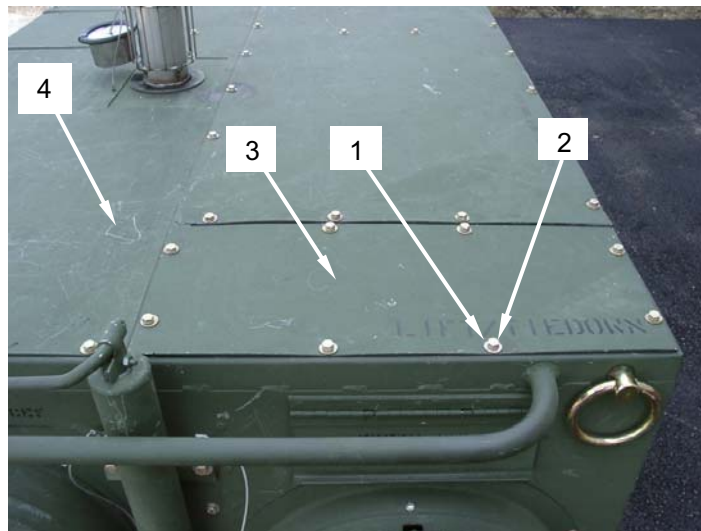

4. Inspect the carbon monoxide detector (5) and ensure that it has not been damaged in any way. Ensure that the louvers (6) are not blocked or damaged in such a way as to prevent proper airflow into the detector. Ensure that the indicator lamp (7) is not broken or missing and that the "PUSH TO TEST" button (8) functions properly (note that button does not protrude from cover. If the carbon monoxide detector is damaged, replace as detailed in the section of this work package entitled REPLACE.

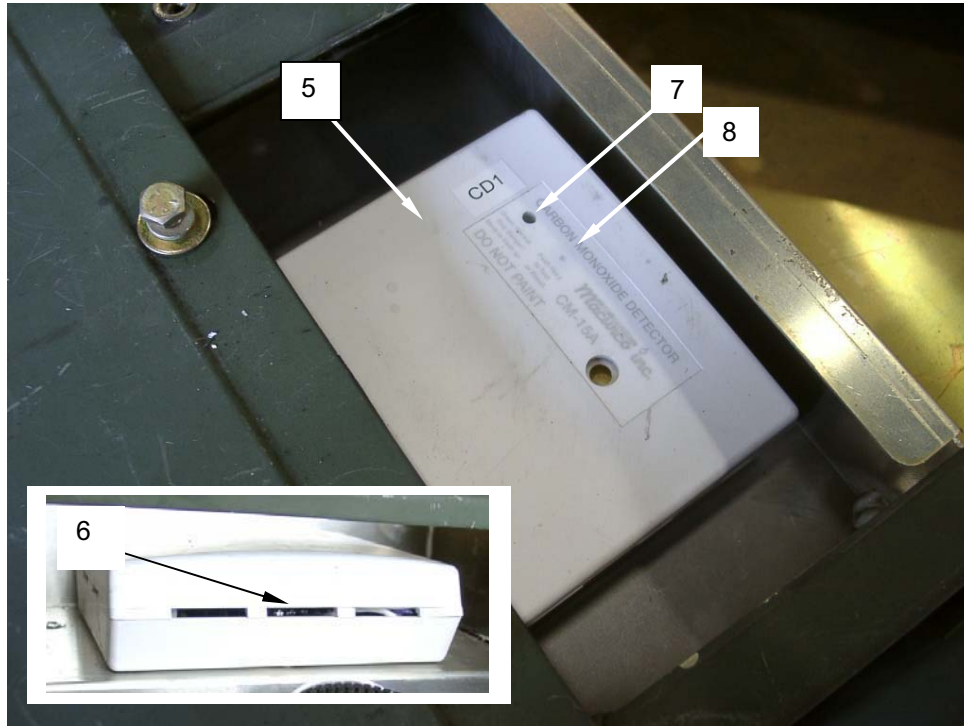

TEST

1. Remove the fan compartment cover as detailed in the INSPECT section of this procedure.
2. The carbon monoxide detector performs a self test when power to the LCFH is applied. The detector may also be directly tested by pressing the "PUSH TO TEST OR RESET" switch (1).
3. To test the CO detector, ensure that the power switch on the operator control box is in the ON position.
4. Within a few seconds of placing the power switch in the ON position, the carbon monoxide detector will produce a series of four chirps followed by a delay of a few seconds, and then four more chirps. This indicates that the carbon monoxide detector is operating properly.
5. The switch (1) on the front of the CO detector labeled "PUSH HERE TO TEST OR RESET" performs a dual function. During normal operations, one push will place the unit into self-test mode. The status light will turn red for five seconds, and then it will alternate slowly between green and amber while the self-test executes. The controlling software rapidly simulates a 300 ppm CO environment, and will cause the unit to alarm after one minute has elapsed. When this happens, the status light will turn red, the alarm relay will close and the buzzer will sound two complete cycles. The unit will then return to normal operation. If the CO detector is in an alarm condition due to detection of carbon monoxide, one push of the switch will cause the alarm buzzer to turn off, and the self-test to start. After the one

minute test if CO is still present, the status light will again switch to RED, the alarm relay will close; and the buzzer will sound.

6. If the detector does not chirp as described in steps 4 or 5, it should be replaced as described in the section of this work package entitled REPLACE.



REPLACE

1. To replace the carbon monoxide detector, remove the fan cover as detailed in the section titled INSPECT.
2. Pry the top cover (1) off the CO detector with a screwdriver.
3. Remove the two screws (2) that secure the inner assembly (3) to the lower portion (4) of the plastic case.
4. Partially remove the inner assembly (3) from the lower portion (4) of the plastic case.
5. Remove the screws (5) that secure the lower portion (4) of the plastic case to the mounting plate (6).
6. Remove the lower portion (4) of the plastic case from the mounting plate (6).
7. Disconnect the wiring harness connector (7) connecting the carbon monoxide detector to the heater.

NOTE

It is necessary to partially disassemble the new carbon monoxide detector before it can be installed in the heater.

8. Connect the wiring harness connector (7) of the new carbon monoxide detector to the wiring harness in the heater.
9. Pry the top cover (1) off the new carbon monoxide detector with a screwdriver.

10. Remove the two screws (2) that secure the inner assembly (3) to the lower portion (4) of the plastic case.
11. Partially remove the inner assembly (3) to gain access to the lower portion (4) of the plastic case.
12. Position the lower portion (4) of the plastic case over the holes in the mounting plate (6).
13. Install the screws (5) that secure the lower portion (4) of the plastic case to the mounting plate (6).
14. Install the inner assembly (3) into the lower portion (4) of the plastic case aligning the holes on the inner assembly with mounting studs on the lower portion of the plastic case.
15. Install two screws (2) and secure the inner assembly (3).
16. Install the top cover (1) and snap into place.
17. Repeat the TEST procedure outlined earlier in this work package to ensure that CO detector is fully operational.

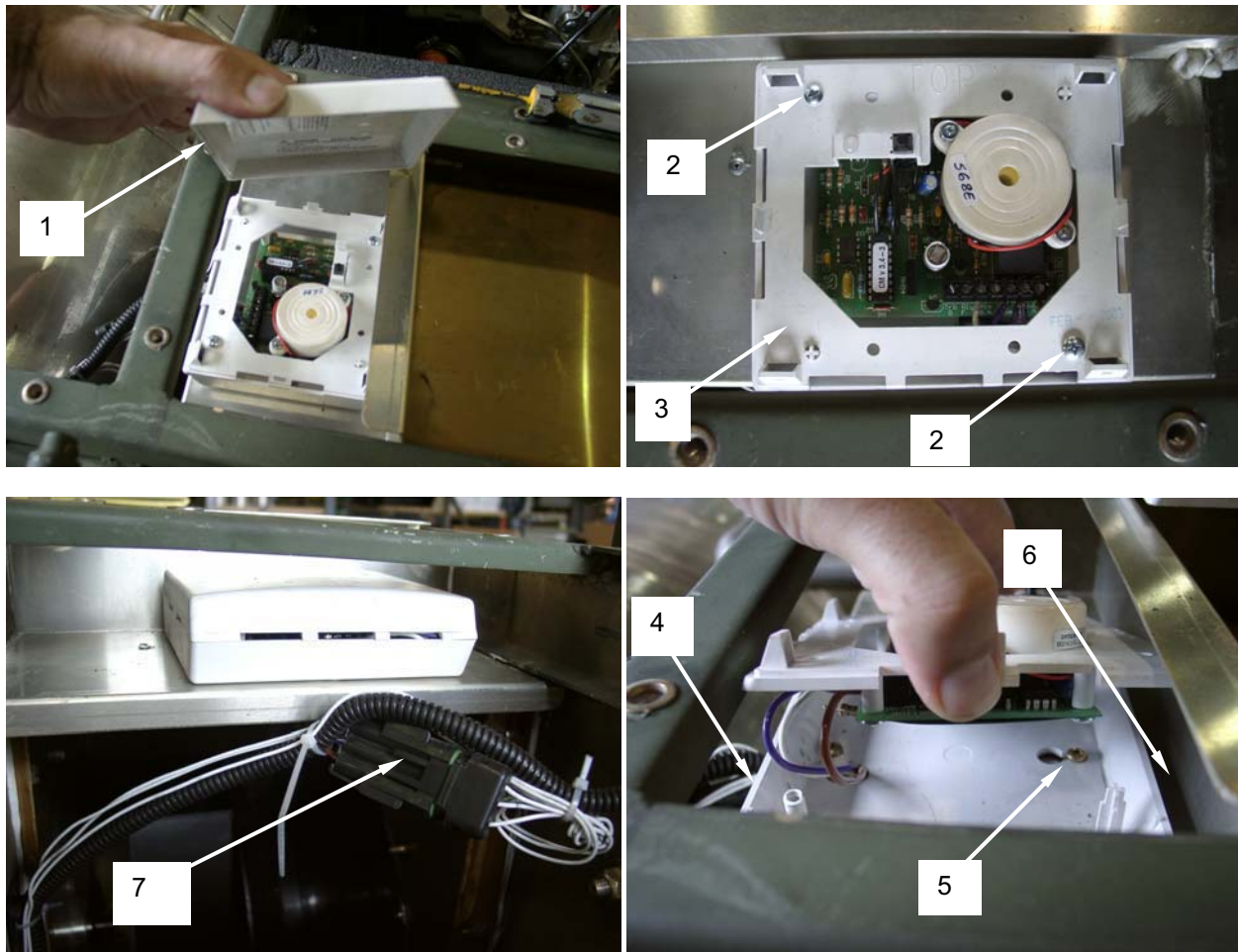

END OF WORK PACKAGE

FIELD (UNIT) MAINTENANCE
LARGE CAPACITY FIELD HEATER

NSN 4520-01-500-1534

ENGINE SHUTDOWN SOLENOID AND CABLE
SERVICE, REPLACE

INITIAL SETUP:

Tools

Tool Kit, General Mechanics (Item 1, WP 0092 00)

Personnel Required

MOS 63J or 52C

Materials/Parts

Pin, cotter (Item 30, WP 0119 00)
 Lubricant, silicone (Item 3, WP 0119 00)

Equipment Condition

Heater shut down and cool (WP 0005 00)
 Main battery switch OFF and handle removed.

SERVICE

To lubricate the engine shutdown cable, spray silicon lubricant into the end of the cable housing at both the solenoid end **(1)** and engine end **(2)**.

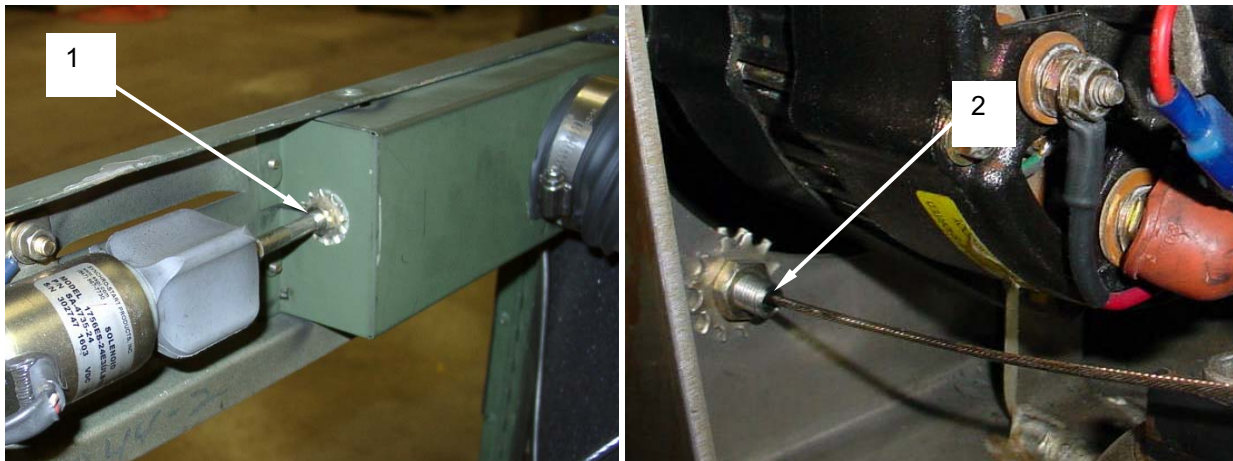

REPLACE CABLE

1. Remove the cotter pin **(1)** that secures the end of the shutdown cable **(2)** and disengage the cable end from the engine throttle **(3)**. Discard cotter pin.
2. Remove the nut **(4)** and lockwasher **(5)** that secure the cable housing **(2)** to the engine mounting plate **(6)**.
3. Remove the four screws **(7)** and lockwashers that secure the engine cooling air inlet **(8)** and set aside.
4. Remove the nut **(9)** and lockwasher **(10)** that secure the cable housing to the engine cooling air inlet **(8)**.

5. Remove the cable (2) from the end of the shutdown solenoid (11) by holding the cable end stationary while rotating the shutdown solenoid shaft (12).
6. Remove defective cable (2).
7. Install a new cable by threading through the grommets on the engine cooling air inlet (8) and the engine mounting plate (6).
8. Install end of cable to shutdown solenoid shaft (12).
9. Install engine cooling air inlet (8) with four screws (7) and lockwashers removed earlier.
10. Secure cable to engine mounting plate (6) with nut (4) and lockwasher (5) removed earlier.
11. Install end of cable to engine throttle (3). Secure with new cotter pin (1).

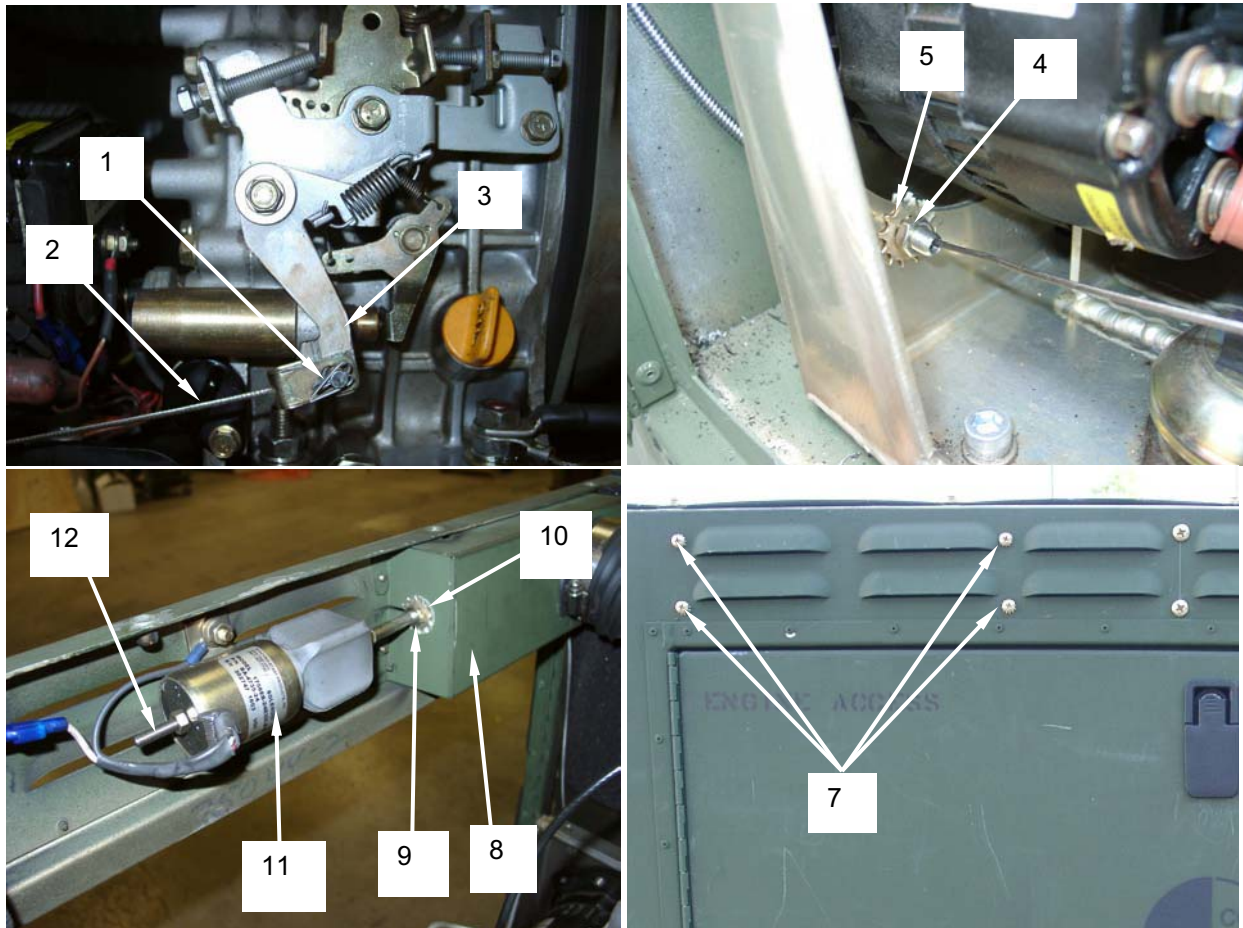

REPLACE ENGINE SHUTDOWN SOLENOID

1. Tag and mark the two wires from the engine shutdown solenoid **(1)**.
2. Disconnect the engine shutdown solenoid wire **(2)** by separating the two halves of the connector **(3)**.
3. Remove the hex nut **(4)**, lock washer **(5)**, and ground wire **(6)** at the top of the engine shutdown solenoid bracket **(7)**.
4. Remove the hex nut **(8)** and lock washer **(9)** at the bottom of the engine throttle solenoid bracket **(7)**.
5. Loosen the hex nut **(10)** on the cable retainer **(11)** and remove cable **(12)**.
6. Remove defective engine shutdown solenoid **(1)**.
7. Loosen the hex nut **(10)** on the cable retainer **(11)** of the new engine shutdown solenoid **(1)** and insert cable **(12)**. Tighten hex nut **(10)** securely.
8. Install new engine shutdown solenoid **(1)** by aligning holes in solenoid bracket **(7)** with threaded studs **(13)** of cabinet.
9. Install lock washer **(9)** and hex head bolt **(8)** at the bottom of the engine throttle solenoid bracket **(7)**. Tighten securely.
10. Install lock washer **(5)**, ground wire **(6)**, and hex head bolt **(4)** at the top of the engine throttle solenoid bracket **(7)**. Tighten securely.
11. Reconnect engine shutdown solenoid wire **(2)** by engaging both halves of the connector **(3)**.
12. Remove all tags and markings.

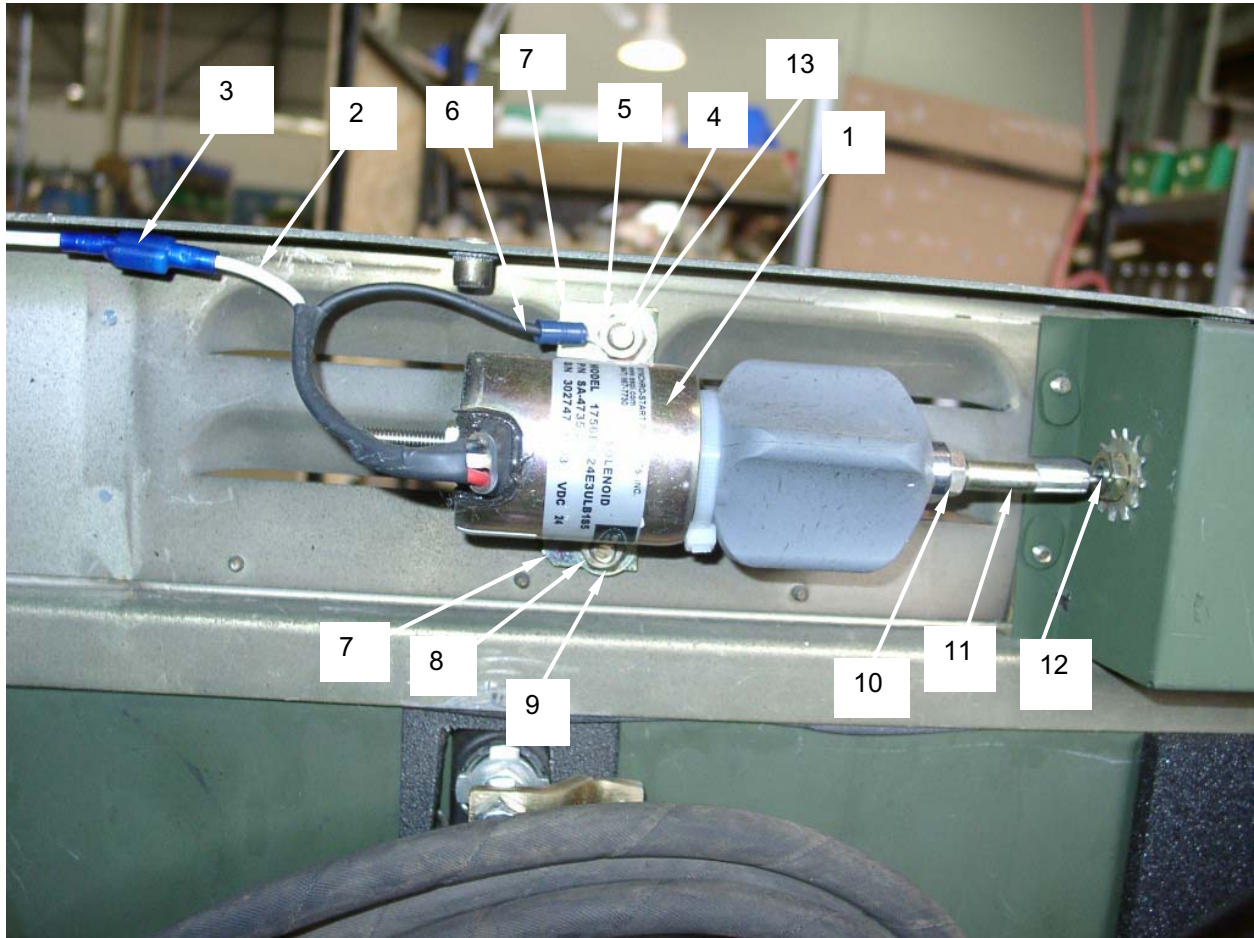

END OF WORK PACKAGE

FIELD (UNIT) MAINTENANCE

LARGE CAPACITY FIELD HEATER

NSN 4520-01-500-1534

FUEL FILTER
SERVICE, REPLACE**INITIAL SETUP:****Tools**

Tool Kit, General Mechanics (Item 1, WP 0092 00)
Wrench, Oil Filter (Item 19, WP 0092 00)

Personnel Required

MOS 63J or 52C

Materials/Parts

Rags, Wiping (Item 4, WP 0119 00)
Sealant, Thread (Item 2, WP 0119 00)

Equipment Condition

Heater shut down and cool (WP 0005 00)
Main battery switch OFF and handle removed.

SERVICE

1. To service the fuel filter, unscrew the fuel filter cartridge **(1)** with an oil filter wrench. Wipe up any spilled fuel with a rag.
2. Discard old fuel filter cartridge **(1)** in accordance with Unit SOP and local environmental regulations.
3. Install a new fuel filter cartridge **(1)** by engaging the opening on the top of the fuel filter cartridge with the threaded filter fitting. Hand tighten only.

REPLACE

1. Loosen fitting **(2)** and remove hose **(3)** from the fuel filter housing **(4)**.
2. Remove fitting **(5)**, clean any residual pipe joint compound or teflon tape and set aside.
3. Loosen fitting **(6)** and remove hose **(7)** from fuel filter housing **(4)**.
4. Note orientation and remove the elbow fitting **(8)**, clean any residual pipe joint compound or teflon tape and set aside.
5. Remove reducing fitting **(9)**, clean any residual pipe joint compound or teflon tape and set aside.
6. Loosen fitting **(10)** and remove hose **(11)** from fuel filter housing **(4)**.
7. Note orientation and remove the elbow fitting **(12)**, clean any residual pipe joint compound or teflon tape and set aside.
8. Remove reducing fitting **(13)**, clean any residual pipe joint compound or teflon tape and set aside.
9. Remove fuel filter housing mounting bolt **(14)**, nut **(15)**, and flat washer **(16)** on right side of housing.
10. Remove fuel filter housing mounting bolt **(17)**, nut **(18)**, and flat washer **(19)** on left side of housing.

-
11. Remove fuel filter housing **(4)**.
 12. Position new fuel filter housing **(4)** and install the right mounting bolt **(14)**, flat washer **(16)**, and nut **(15)**.
 13. Install left mounting bolt **(17)**, flat washer **(19)**, and nut **(18)**. Tighten both bolts securely.
 14. Apply new pipe joint compound and install reducing fitting **(13)** that was set aside earlier
 15. Apply new pipe joint compound and install the elbow fitting **(12)** in the same orientation as noted earlier.
 16. Install hose **(11)** on fuel filter housing **(4)** and tighten fitting **(10)**.
 17. Apply new pipe joint compound and install reducing fitting **(9)** that was set aside earlier
 18. Apply new pipe joint compound and install the elbow fitting **(8)** in the same orientation as noted earlier.
 19. Install hose **(7)** on fuel filter housing **(4)** and tighten fitting **(6)**.
 20. Apply new pipe joint compound and install fitting **(5)** set aside earlier.
 21. Install hose **(3)** and tighten fitting **(2)** on the fuel filter housing **(4)**.
 22. Install new fuel filter cartridge **(1)** if not already installed on fuel filter housing **(4)**.

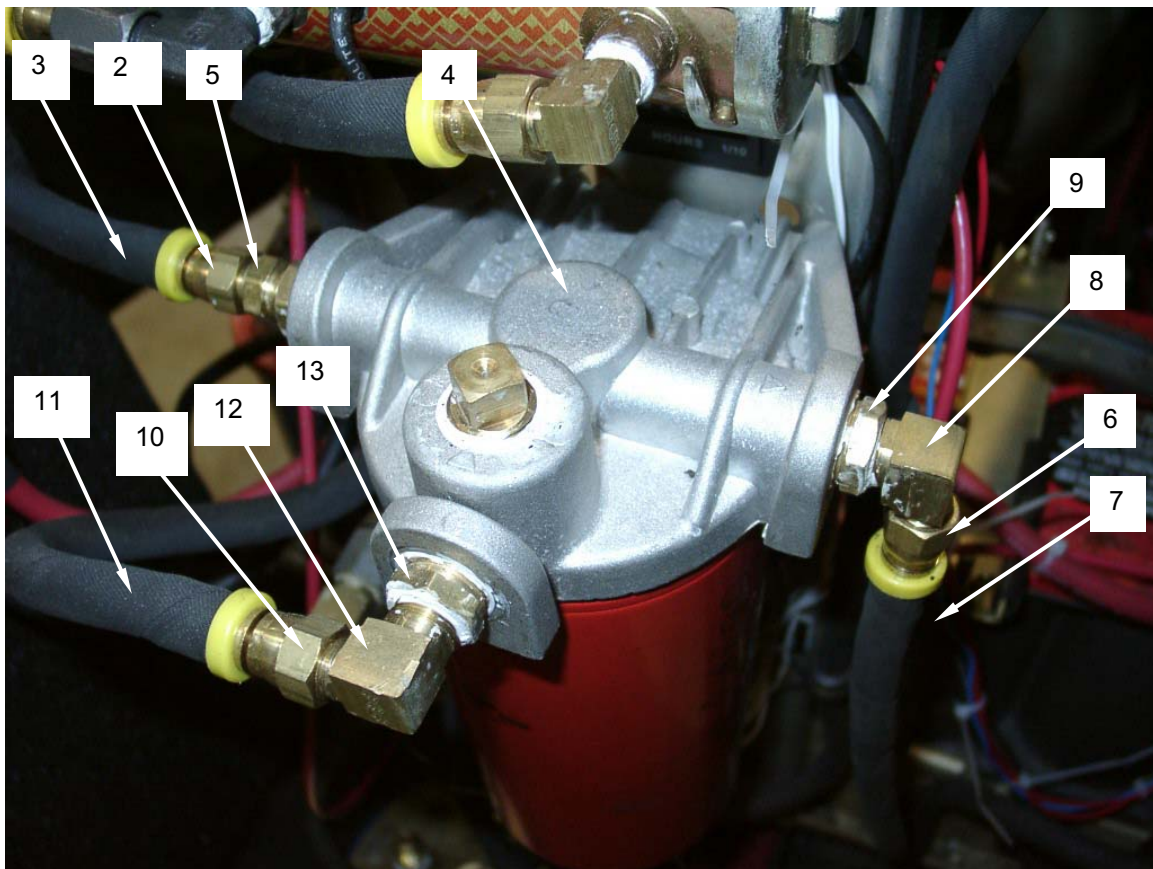

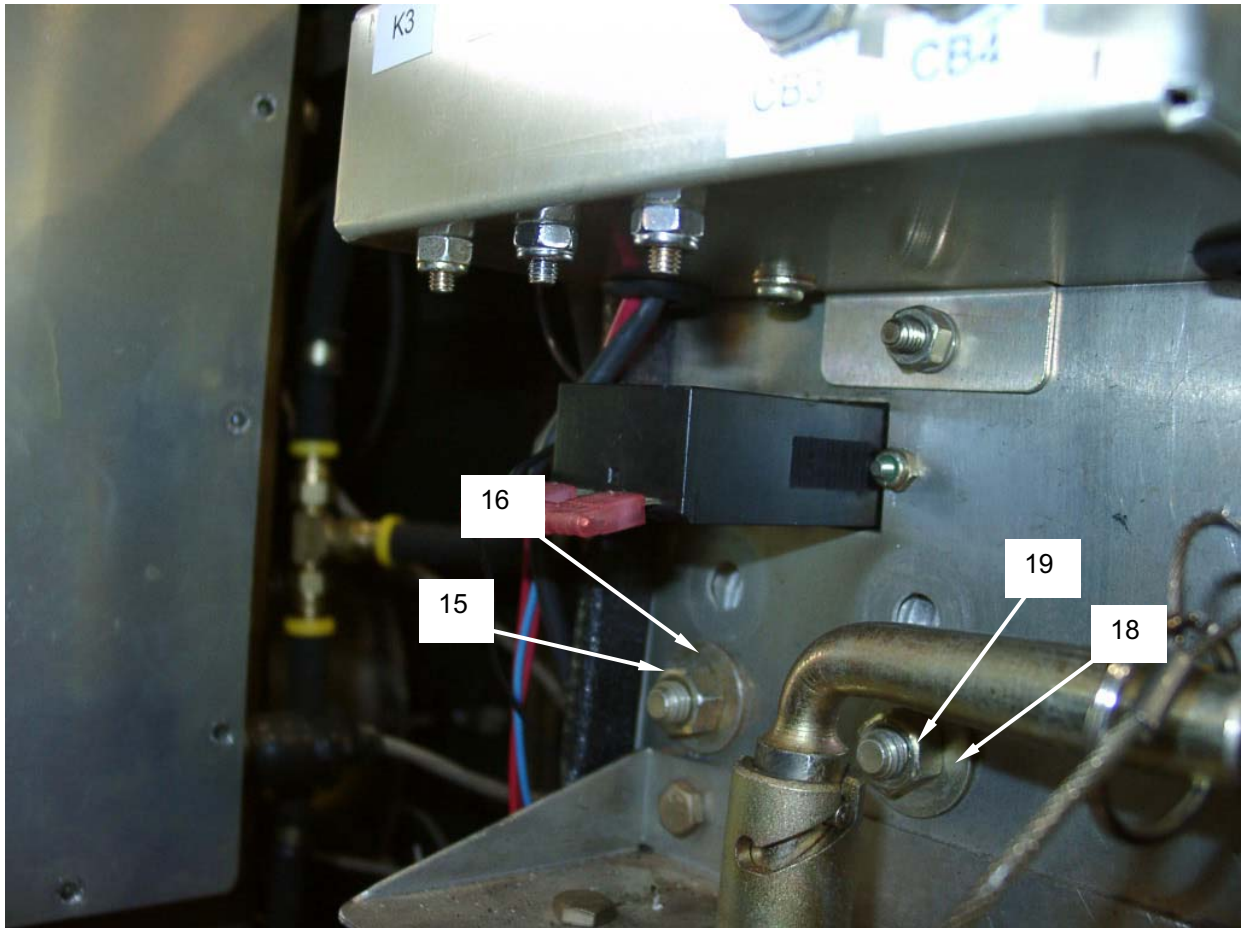
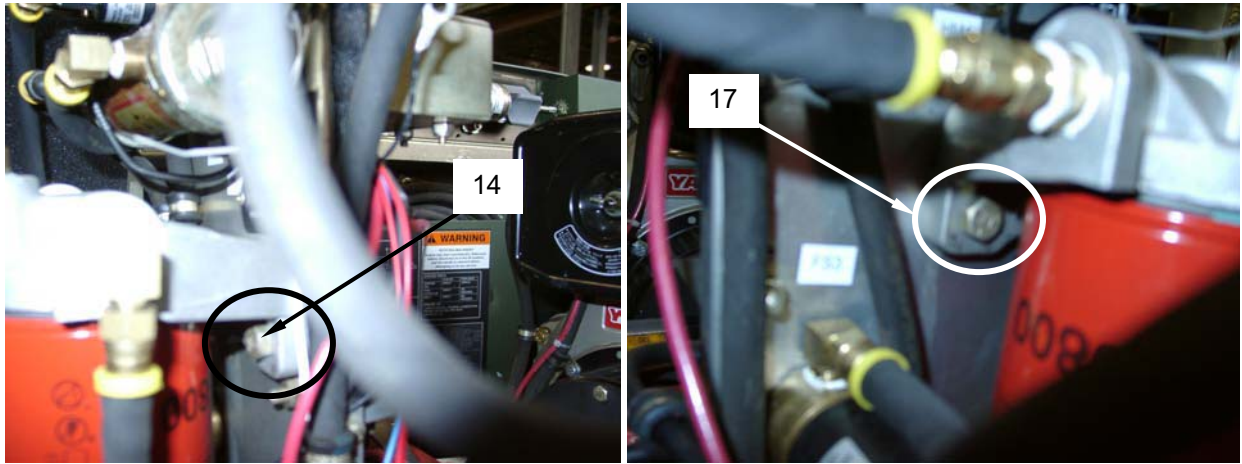

END OF WORK PACKAGE

FIELD (UNIT) MAINTENANCE**LARGE CAPACITY FIELD HEATER**

NSN 4520-01-500-1534

**ELECTRICAL FUEL PUMP
SERVICE, REPLACE****INITIAL SETUP:****Tools**

Tool Kit, General Mechanics (Item 2, WP 0092 00)

Personnel Required

MOS 63J or 52C

Materials/Parts

Sealant, thread (Item 2, WP 0119 00)

Equipment ConditionHeater shut down and cool (WP 0005 00)
Main battery switch OFF and handle removed.**WARNING**

Fuel is toxic. Be sure to place a petroleum absorbent mat or tray below the fuel pump to collect any fuel. Be sure to wipe up any spills with a rag.

SERVICE

1. To service the fuel pump **(1)**, rotate the base cover **(2)** counterclockwise until it unlocks.
2. Carefully remove the base cover **(2)** taking care to catch any fuel that may spill.
3. Remove the fuel pump strainer **(3)** and clean using clean fuel or solvent.
4. After servicing, install the fuel pump strainer **(3)** into the fuel pump **(1)**.
5. Install the base cover **(2)** and rotate clockwise to lock in position.

REPLACE

1. Disconnect the electrical connector **(4)** by pulling the two halves of the connector apart.
2. Loosen the fitting **(5)** on the fuel outlet hose **(6)** and remove, taking care to catch any fuel that may spill.
3. Loosen the fitting **(7)** on the fuel inlet hose **(8)** and remove, taking care to catch any fuel that may spill.
4. Take note of the orientation of the elbow fitting **(9)** on the outlet port **(10)** of the fuel pump and remove. Clean any residual thread sealant that may be on the threads of the elbow fitting and set aside.

5. Take note of the orientation of the brass elbow fitting **(11)** on the inlet port **(12)** of the fuel pump and remove. Clean any residual thread sealant that may be on the threads of the elbow fitting and set aside.
6. Remove the upper bolt **(13)** securing the fuel pump by removing the nut **(14)** and lock washer **(15)** on the rear of the fuel pump mounting panel.
7. Remove the lower bolt **(16)** securing the fuel pump by removing the nut **(17)** and lock washer **(18)** on the rear of the fuel pump mounting panel **(19)**.
8. Remove the defective fuel pump **(1)**.
9. Install a new fuel pump **(1)** by positioning over the two mounting holes on the fuel pump mounting panel **(19)**.
10. Install the upper mounting bolt **(13)** and secure with a lock washer **(15)** and nut **(14)** from the rear side of the fuel pump mounting panel **(19)**.
11. Install the lower mounting bolt **(16)** and secure with a lock washer **(18)** and nut **(14)** from the rear side of the fuel pump mounting panel **(19)**.
12. Apply new thread sealant to the threads of the brass elbow fitting **(11)** and install in the fuel inlet port **(12)** of the fuel pump taking care to orient the fitting as before.
13. Apply new thread sealant to the threads of the elbow fitting **(9)** and install in the fuel outlet port **(10)** of the fuel pump taking care to orient the fitting as before.
14. Install the fitting **(7)** of the fuel inlet hose **(8)** on the brass elbow fitting **(11)** located at the fuel inlet port, tightening securely.
15. Install the fitting **(5)** of the fuel outlet hose **(6)** on the elbow fitting located at the fuel outlet port, tightening securely.
16. Reconnect the electrical connector **(4)** by engaging the two halves of the connector until they are firmly seated.

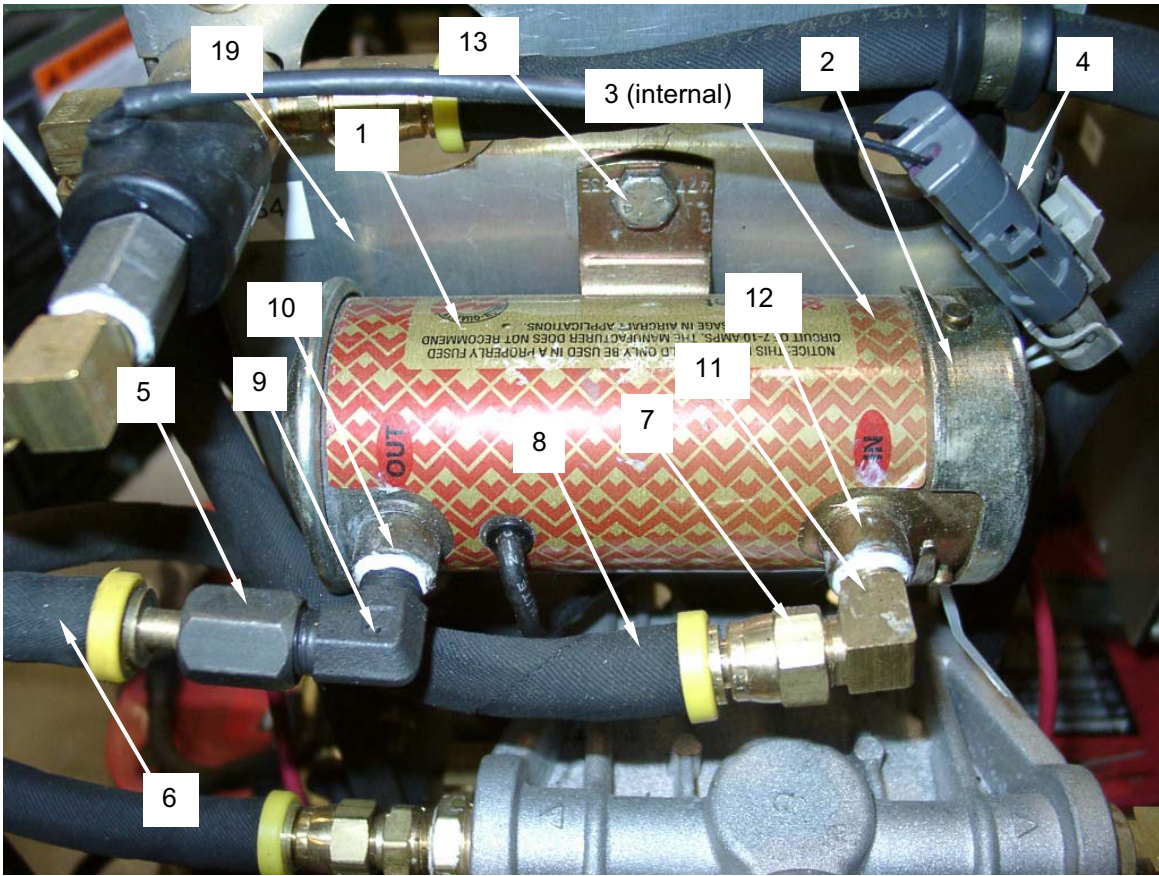

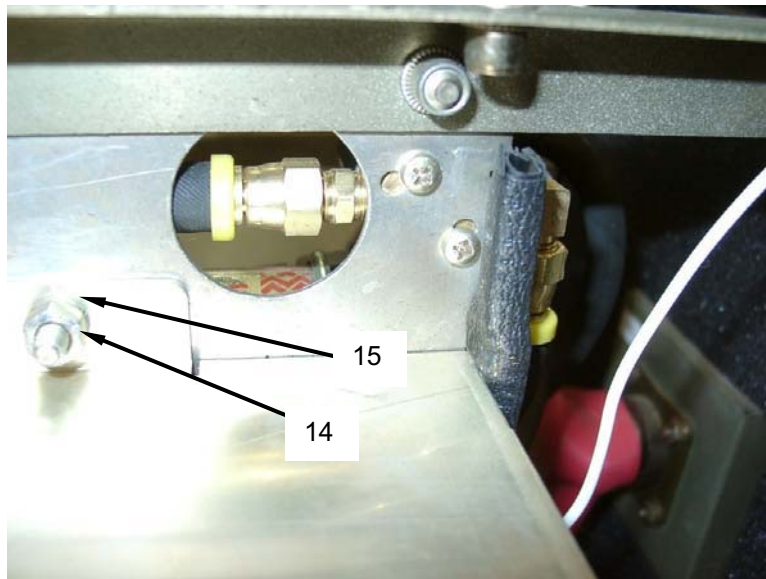
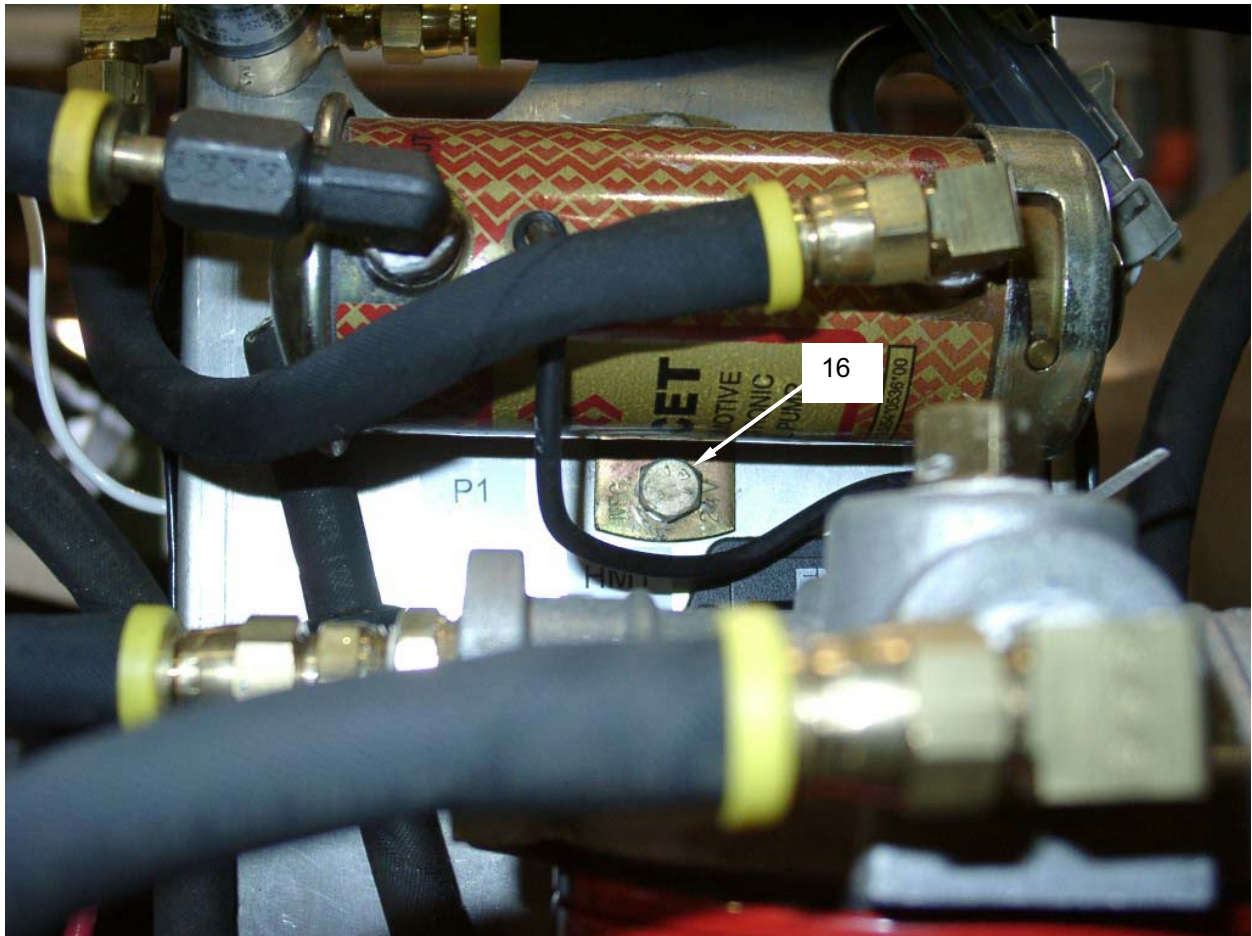

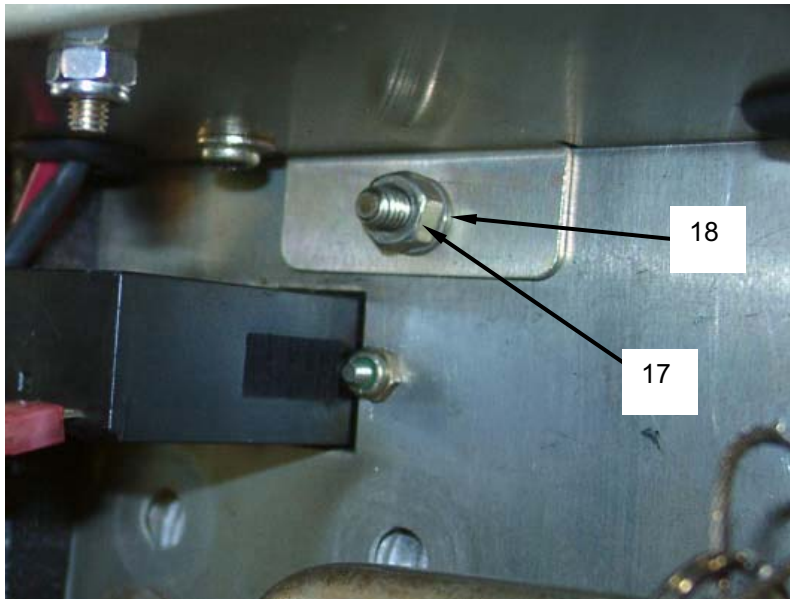

END OF WORK PACKAGE

FIELD (UNIT) MAINTENANCE
LARGE CAPACITY FIELD HEATER

NSN 4520-01-500-1534

3-WAY FUEL SOLENOID VALVE
REPLACE

INITIAL SETUP:

Tools

Tool Kit, General Mechanics (Item 2, WP 0092 00)

Personnel Required

MOS 63J or 52C

Materials/Parts

Sealant, Thread (Item 2, WP 0119 00)
Rags, Wiping (Item 4, WP 0119 00)
Mat, Petroleum Absorbent, GOV106 (1JA49) (Item 8, WP 0119 00)
Tray, Petroleum Absorbent, GOV103, (1JA49) (Item 10, WP 0119 00)
Tags, Marking, MIL-T-12755 (81349) (Item 5, WP 0119 00)

Equipment Condition

Heater shut down and cool (WP 0005 00)
Main battery switch OFF and handle removed.

REPLACE



WARNING

Fuel is toxic. Be sure to place a petroleum absorbent mat or tray below the fuel pump to collect any fuel. Be sure to wipe up any spills with a rag.

1. Tag and mark the three fuel hoses that are connected to the solenoid valve.
2. Disconnect the solenoid valve electrical connector **(1)** by separating the two halves.
3. Loosen the compression fitting **(2)** and remove fuel hose #1 **(3)**.
4. Loosen the compression fitting **(4)** and remove fuel hose #2 **(5)**.
5. Loosen the compression fitting **(6)** and remove fuel hose #3 **(7)**.
6. Clean up any spilled fuel with a rag.
7. Remove the elbow fitting **(8)** noting its orientation and set aside. Clean all residual pipe thread sealant from the fitting.
8. Remove the male-to-male threaded fitting **(9)** and set aside. Clean all residual pipe thread sealant from the fitting.
9. Remove elbow **(11)** from solenoid fitting **(10)** and set aside. Clean all residual pipe thread sealant from the fitting.

10. Remove the two mounting screws **(12)** and lockwashers **(13)**.
11. Remove the defective solenoid valve **(14)**.
12. Install a new solenoid valve **(14)** by aligning the holes in the rear of the solenoid valve with the holes in the mounting panel **(15)**.
13. Install the lockwashers **(13)** and mounting screws **(12)**. Tighten securely.
14. Install elbow **(11)** on solenoid fitting **(10)** taking care to align the elbow fitting as noted earlier.
15. Apply pipe thread sealant to one end of the male-to-male threaded fitting **(9)**.
16. Install the end of the male-to-male threaded fitting **(9)** with the applied pipe thread sealant into the fitting **(16)** on the right side of the solenoid valve **(14)**. Tighten securely.
17. Apply new pipe thread sealant to one end of elbow fitting **(8)**.
18. Install end of elbow fitting **(8)** with pipe thread sealant into the fitting **(17)** on the left side of the solenoid valve **(14)** taking care to align the elbow as noted previously.
19. Install fuel hose #3 **(7)** on compression fitting **(6)**. Tighten securely.
20. Install fuel hose #2 **(5)** on compression fitting **(4)**. Tighten securely.
21. Install fuel hose #1 **(3)** on compression fitting **(2)**. Tighten securely.
22. Reconnect the solenoid valve electrical connector **(1)** by mating the two halves and pushing together until locked.
23. Remove all tags and markings.

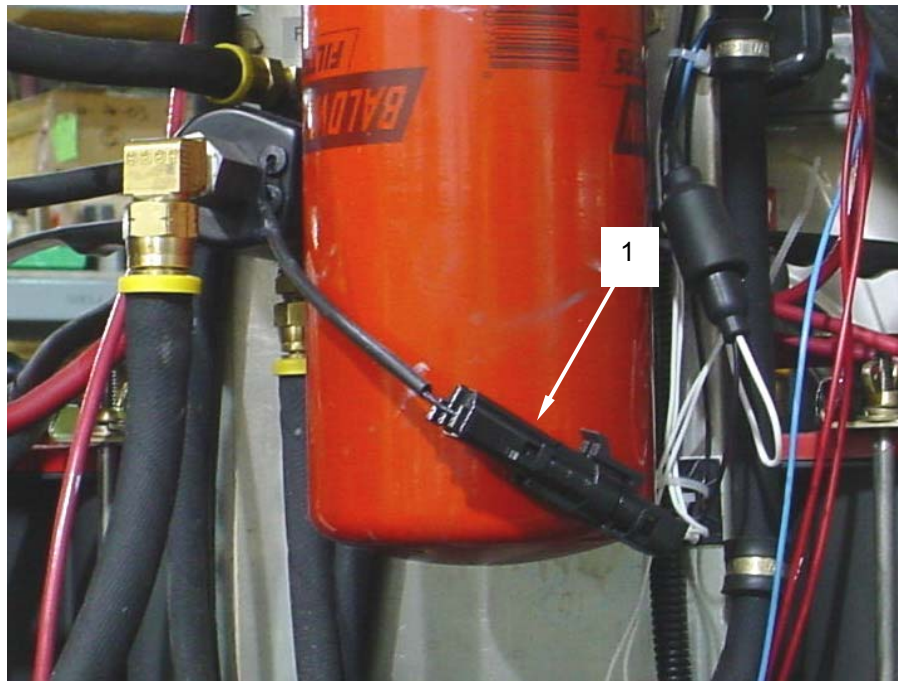
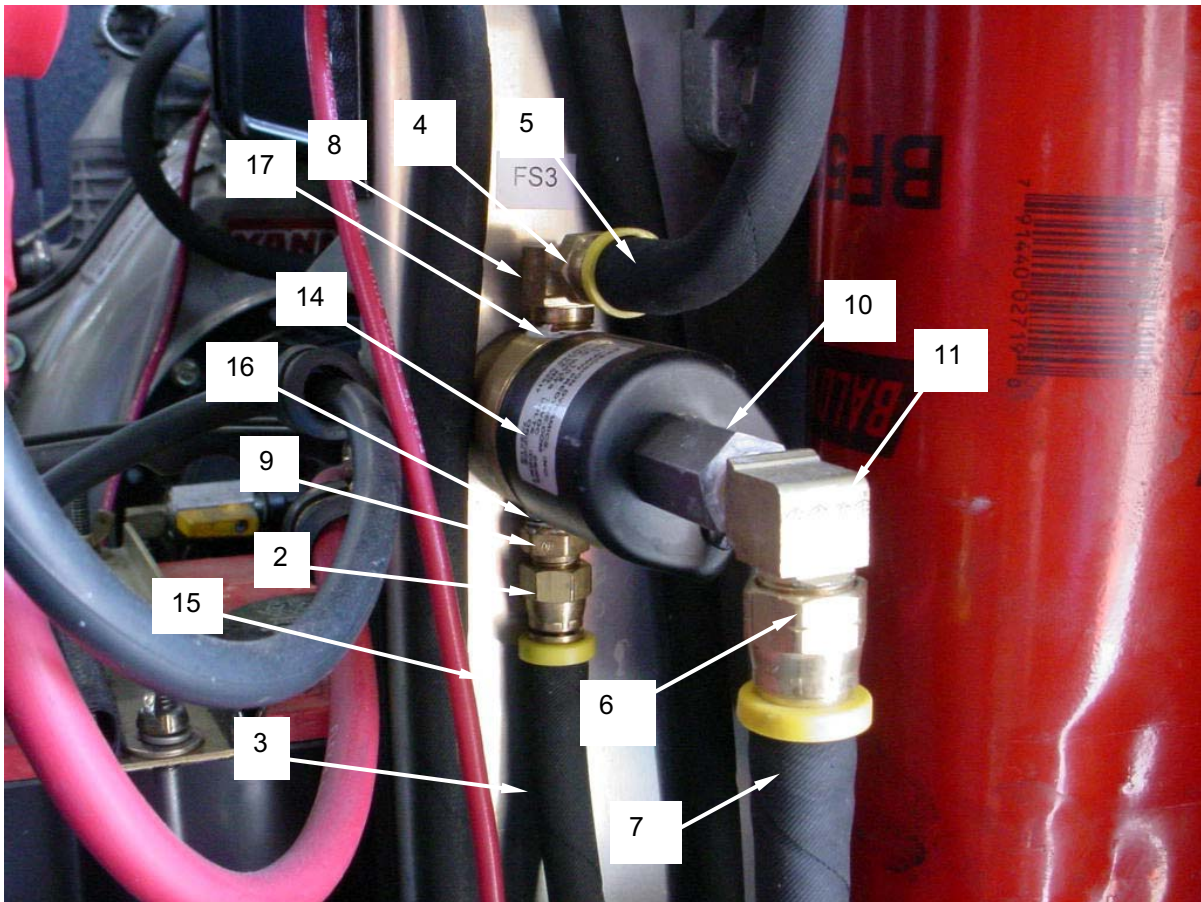

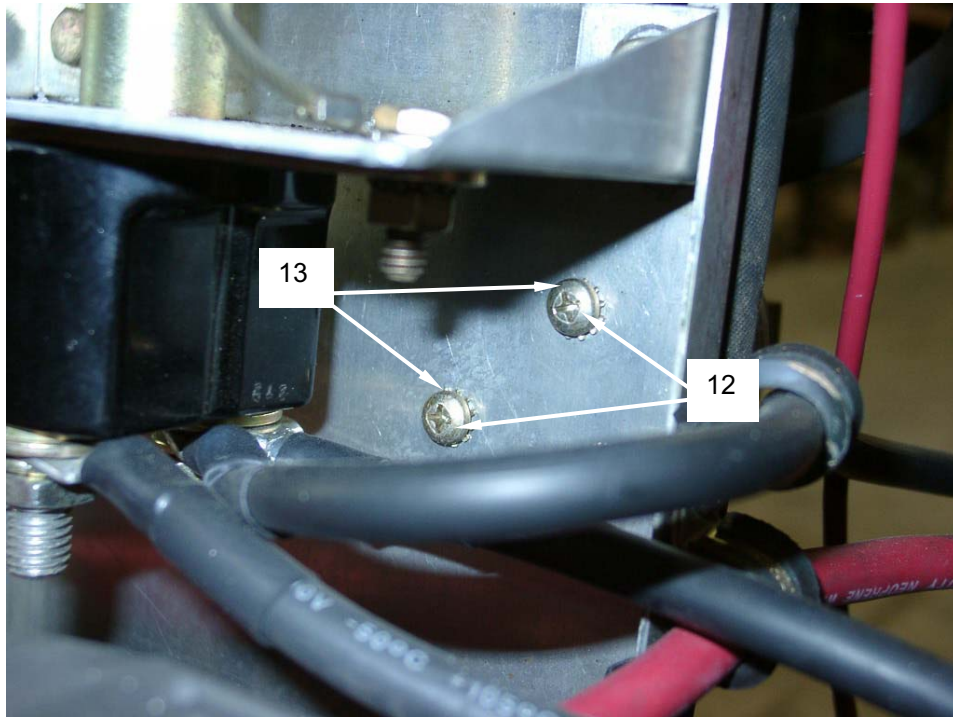

END OF WORK PACKAGE

 FIELD (UNIT) MAINTENANCE

LARGE CAPACITY FIELD HEATER

NSN 4520-01-500-1534

 MAIN BATTERY POWER SWITCH
 TEST, REPLACE

INITIAL SETUP:

Tools

Tool Kit, General Mechanics (Item 2, WP 0092 00)

Personnel Required

MOS 63J or 52C

Materials/Parts

Tags, marking, MIL-T-12755 (Item 5, WP 0119 00)

Equipment Condition

Heater shut down and cool (WP 0005 00)

Disconnect negative battery cable from outboard battery to cut power to the system

TEST

1. Remove cables from main battery power switch **(2)** as detailed in steps 1 through 4 below.
2. Set multimeter to read continuity and place leads of multimeter across the front **(10)** and rear **(7)** studs on the main battery power switch **(2)**.
3. Verify that when the main battery power switch **(2)** is in the ON position, the multimeter reads as a short circuit (continuity) through the main battery power switch.
4. Verify that when the main battery power switch **(2)** is in the OFF position, the multimeter should read as an open circuit through the main battery power switch.

REPLACE

1. Open the engine access door **(1)** to gain access to the main battery power switch **(2)** on the rear of the fuel assembly panel **(3)**.
2. Tag and mark wires connected to main battery power switch **(2)**.
3. Remove rubber insulating boot **(4)**, and then remove nut **(5)** and wire **(6)** from the rear stud **(7)** of the main battery power switch **(2)**.
4. Remove the nut **(8)** and wire **(9)** from the front stud **(10)** of the main battery power switch **(2)**.
5. Remove the two nuts **(11)**, bolts **(12)**, and lockwashers **(13)** that secure the main battery power switch **(2)** to the fuel assembly panel mounting bracket **(14)**.
6. Remove main battery power switch handle.
7. Remove the defective main battery power switch **(2)**.

8. Install a new main battery power switch (2) by aligning the holes in the switch mounting plate (15) with the holes in the fuel assembly panel mounting bracket (14).
9. Install main battery power switch handle. Ensure that the handle (16) faces towards the engine access door, and that the switch is in the OFF position.
10. Install the two bolts (12), lockwashers (13), and nuts (11) that secure the main battery power switch (2) to the fuel assembly panel mounting bracket (14) and tighten securely.
11. Install the cable (6) to the rear stud (7) of the main battery power switch (2). Install nut (5). Tighten securely.
12. Install the cable (9) to the front stud (10) of the main battery power switch (2). Install nut (8). Tighten securely, and install rubber insulation boot (4).
13. Remove all tags and markings from wires.
14. Reconnect negative battery cable too negative terminal of outboard battery.
15. Close and latch engine bay access door (1).



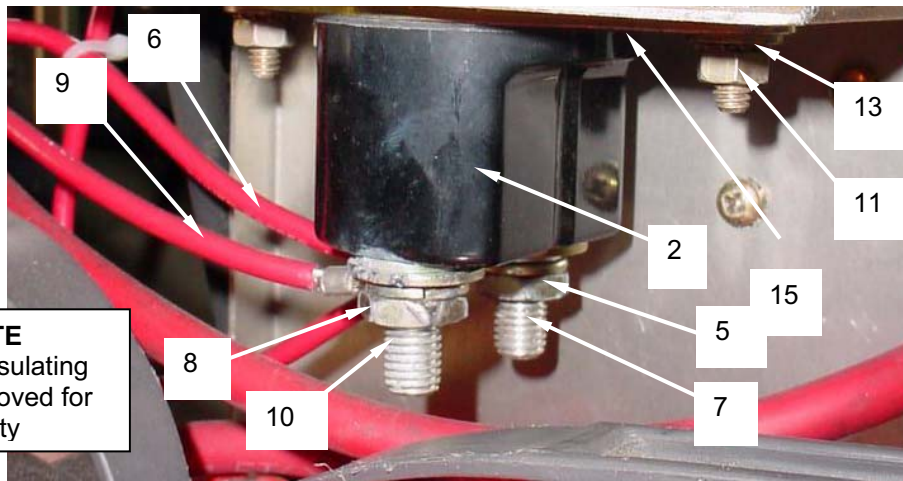
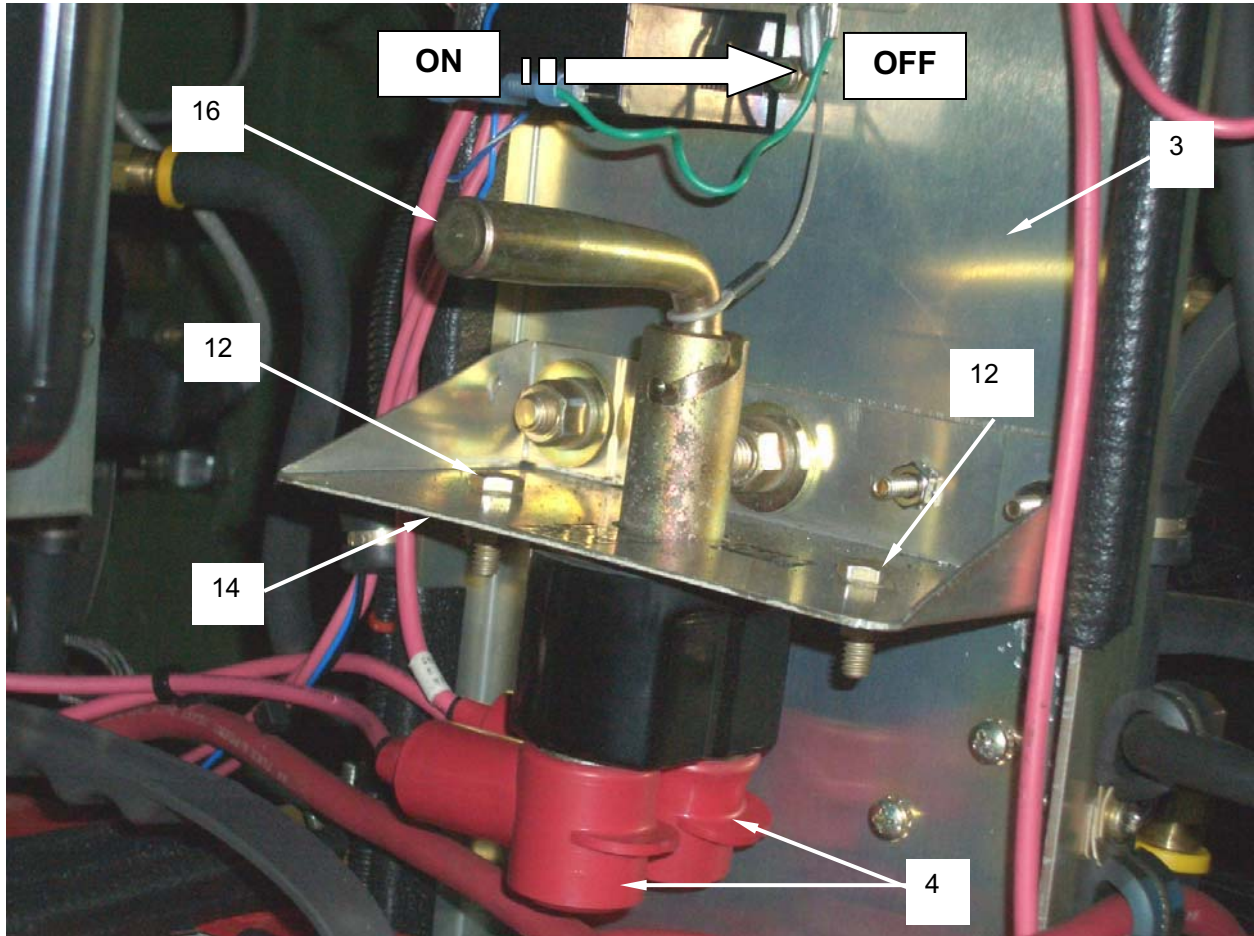

NOTE
Rubber insulating boots removed for clarity

END OF WORK PACKAGE

FIELD (UNIT) MAINTENANCE

LARGE CAPACITY FIELD HEATER

NSN 4520-01-500-1534

3-WAY FUEL SOLENOID VALVE
REPLACE

INITIAL SETUP:

Tools

Tool Kit, General Mechanics (Item 2, WP 0092 00)

Personnel Required

MOS 63J or 52C

Materials/Parts

Sealant, thread (Item 2, WP 0119 00)
Mat, Petroleum Absorbent (Item 8, WP 0119 00)

Equipment Condition

Heater shut down and cool (WP 0005 00)
Main battery switch OFF and handle removed.
Heater end panel at fuel filler cap end of heater removed.

REPLACE

**WARNING**

Fuel is toxic. Be sure to place a petroleum absorbent mat or tray below the fuel pump to collect any fuel. Be sure to wipe up any spills with a rag.

1. Remove heater end panel at fuel filler cap end of heater. Remove external fuel hose from fitting on inboard side of end panel. Set cover and all hardware aside.
2. Remove the fuel inlet line (1) by loosening the nut (2) on the elbow fitting (3).
3. Remove the burner feed line (4) by loosening the nut (5) on the elbow fitting (6).
4. Remove the return fuel tube (7) by removing the nut (8) on the top of the 3-way solenoid valve (9) and the nut (10) on the fuel return to tank fitting (11). Set the return fuel tube (7) aside.
5. Disconnect the solenoid wire harness (12) from the 3-way solenoid valve (9).
6. Remove the two screws (13) at the base of the 3-way solenoid valve (9). Set the screws (13) aside.
7. Remove the defective 3-way solenoid valve (9) and attached fittings from the burner valve mounting bracket (14).
8. With the assembly on a work surface, take note of the orientation of the fitting assembly with pressure gauge (18) and remove from the left side of the 3-way solenoid valve (9). Clean any residual sealant from the end of the fitting assembly with pressure gauge (18). Set the fitting assembly aside.
9. Note the orientation of the elbow fitting (6) on the right side of the 3-way solenoid valve (9) and remove. Clean any residual sealant from the end of the elbow fitting. Set the fitting aside. Discard defective 3-way solenoid valve.

10. Remove fitting **(19)** with attached fitting **(16)** from top of the 3-way solenoid valve **(9)**. Clean any residual sealant from fitting **(19)** and set aside.
11. Apply fresh thread sealant to the threads of the fitting assembly with pressure gauge **(18)** set aside earlier and install on the left side of the new 3-way solenoid valve in the same orientation as noted earlier.
12. Apply fresh thread sealant to the threads of the elbow fitting **(6)** set aside earlier and install in the right side of the new 3-way solenoid valve **(9)** in the same orientation as noted earlier.
13. Apply fresh thread sealant to the threads of fitting **(19)** with attached fitting **(16)** set aside earlier and install to the top of the new 3-way solenoid valve **(9)**.
14. Install the new 3-way solenoid valve **(9)** with attached fittings by aligning the holes in the base of the 3-way solenoid valve **(9)** with the holes in the burner valve mounting bracket **(14)**.
15. Install the two screws **(13)** set aside earlier. Tighten securely.
16. Connect the solenoid wire harness **(12)** to the 3-way solenoid valve **(9)**.
17. Install the return fuel tube **(7)** by positioning the short end **(15)** of the return fuel tube **(7)** over the compression fitting **(16)** on the top of the 3-way solenoid valve **(9)**. Engage return fuel tube **(7)** on fitting and secure with compression nut **(8)**.
18. Position the long end **(17)** of the return fuel tube **(7)** over the compression fitting on the top of the fuel return to tank fitting **(11)**. Engage return fuel tube **(7)** on compression fitting **(11)** and secure with compression nut **(10)**.
19. Install burner feed line **(4)** by engaging nut **(5)** on elbow fitting **(6)**. Tighten securely.
20. Install fuel inlet line **(1)** by engaging nut **(2)** on elbow fitting **(3)**. Tighten securely.
21. Install heater end panel and external fuel hose. Tighten all mounting hardware securely.

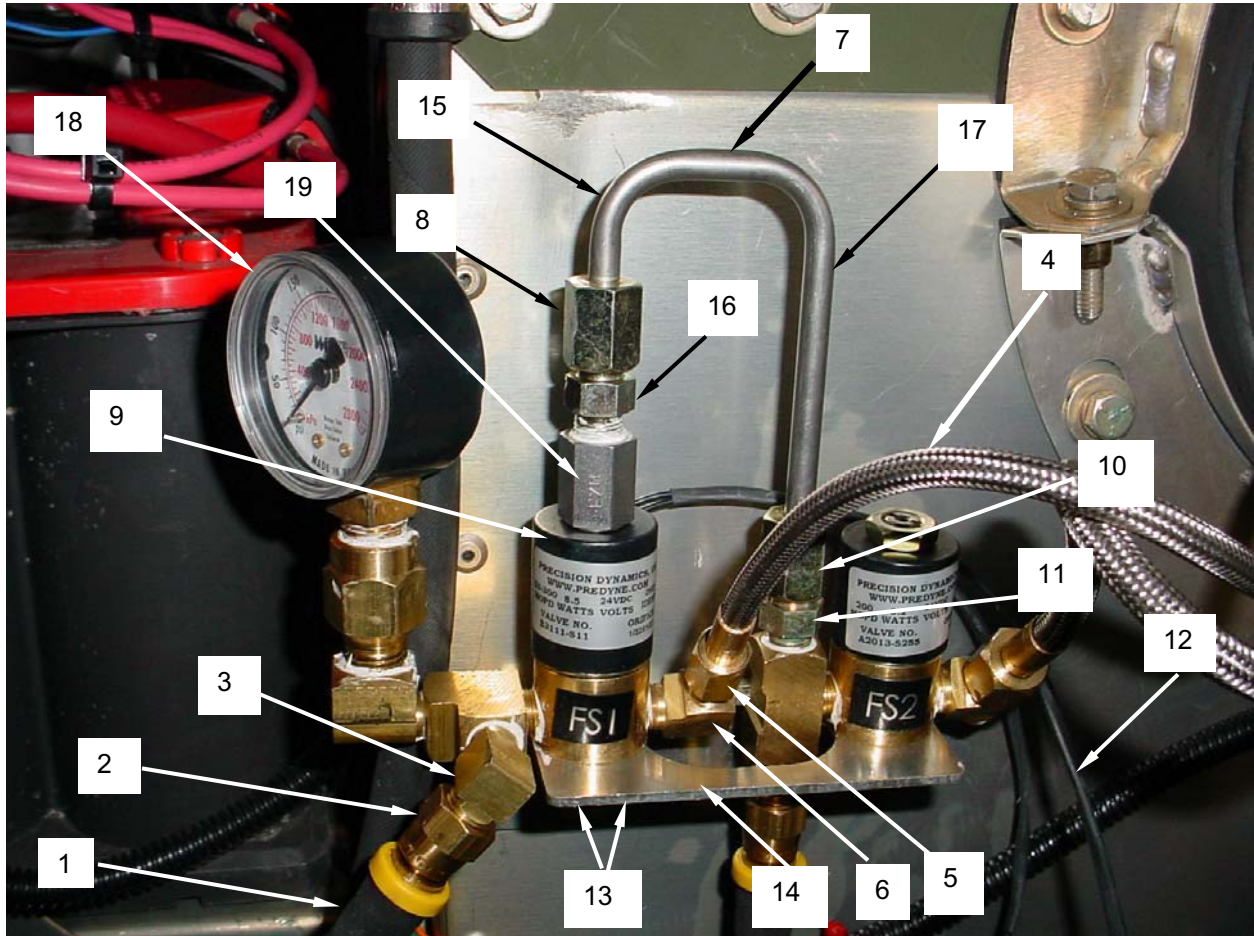

END OF WORK PACKAGE

FIELD (UNIT) MAINTENANCE

LARGE CAPACITY FIELD HEATER

NSN 4520-01-500-1534

2-WAY FUEL SOLENOID VALVE
REPLACE

INITIAL SETUP:

Tools

Tool Kit, General Mechanics (Item 2, WP 0092 00)

Personnel Required

MOS 63J or 52C

Materials/Parts

Sealant, thread (Item 2, WP 0119 00)
Mat, Petroleum Absorbent (Item 8, WP 0119 00)

Equipment Condition

Heater shut down and cool (WP 0005 00)
Main battery switch OFF and handle removed.
Heater end panel at fuel filler cap end of heater removed.

REPLACE

**WARNING**

Fuel is toxic. Be sure to place a petroleum absorbent mat or tray below the fuel pump to collect any fuel. Be sure to wipe up any spills with a rag.

1. Remove heater end panel at fuel filler cap end of heater. Remove external fuel hose from fitting on inboard side of end panel. Set cover and all hardware aside.
2. Remove the return fuel tube **(1)** by removing the nut **(2)** on the top of the 3-way solenoid valve fitting **(3)** and the nut **(4)** on the fuel return to tank fitting **(5)**. Set the return fuel tube aside.
3. Remove burner feed line **(6)** from elbow fitting **(7)** on the right side of the 2-way solenoid valve **(8)**.
4. Note the orientation of the elbow fitting **(7)**, and remove the elbow fitting from the right side of the 2-way solenoid valve **(8)**. Clean residual sealant or antiseize tape from fitting and set aside.
5. Remove the fuel hose fitting **(9)** entering the tee fitting **(10)** on the 2-way solenoid valve **(8)**.
6. Disconnect the solenoid wire harness **(11)** from the 2-way solenoid valve **(8)**.
7. Remove the two screws **(12)** at the base of the 2-way solenoid valve **(8)**. Set the screws aside.
8. Remove the defective 2-way solenoid valve **(8)**.
9. Note the orientation of the tee fitting **(10)**, and remove the tee fitting from the left side of the 2-way solenoid valve **(8)**. Clean residual sealant or antiseize tape from the fitting and set aside.
10. Apply fresh thread sealant to the threads of the tee fitting **(10)**, and install the tee fitting on the new 2-way solenoid valve **(8)**. Ensure the fitting is secure and correctly aligned.

11. Install the new 2-way solenoid valve (8) with tee fitting (10) attached by aligning the holes in the base of the 2-way solenoid valve with the holes in the burner valve mounting bracket (13).
12. Install the two screws (12) set aside earlier. Tighten securely.
13. Apply fresh thread sealant to the threads of the elbow fitting (7) set aside earlier and install the elbow fitting to the right side of the new 2-way solenoid valve (8). Ensure the fitting is both tight and correctly aligned.
14. Install burner feed line (6) on elbow fitting (7) on the right side of the 2-way solenoid valve (8).
15. Connect the solenoid wire harness (11) to the 2-way solenoid valve (8).
16. Install the return fuel tube (1) by positioning the short end of the return fuel tube over fitting (3) on the top of the 3-way solenoid valve.
17. Position the long end of the return fuel tube (1) over the fuel return to tank fitting (5). Engage return fuel tube nut (4) on compression fitting (5) and secure.

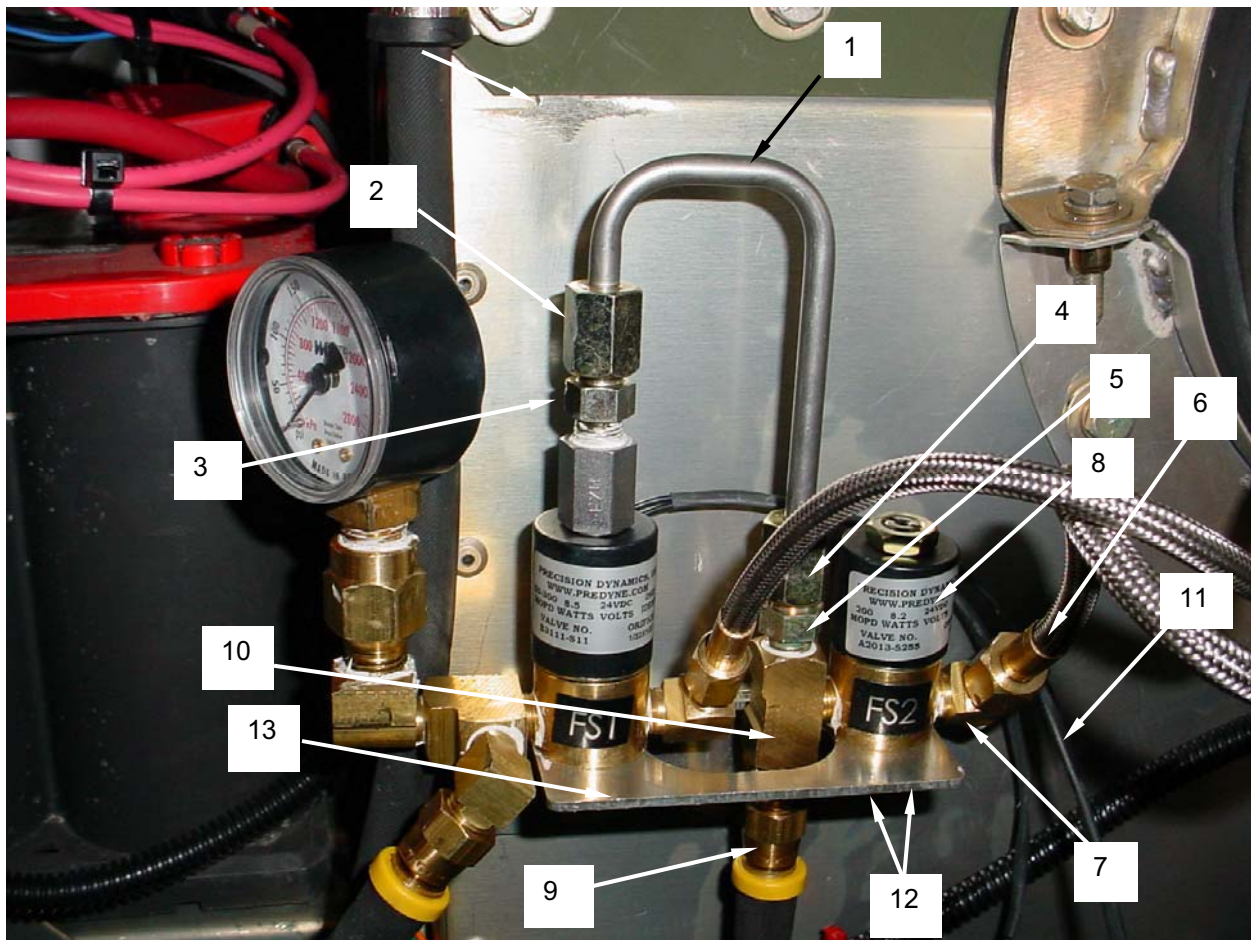

END OF WORK PACKAGE

FIELD (UNIT) MAINTENANCE
LARGE CAPACITY FIELD HEATER
NSN 4520-01-500-1534
BURNER FUEL PUMP ASSEMBLY
INSPECT, REPLACE, ADJUST

INITIAL SETUP:**Tools**

Tool Kit, General Mechanics (Item 2, WP 0092 00)

Personnel Required

MOS 63J or 52C

Materials/Parts

Sealant, thread (Item 2, WP 0119 00)

Rags, wiping, clean (Item 4, WP 0119 00)

Equipment Condition

Heater shut down and cool (WP 0005 00)

Engine bay access door open (WP 0002 00)

Main battery switch in the OFF position and the handle removed.

INSPECT

1. Turn the motor shaft **(1)** by placing the left hand on the coupling assembly **(2)** (see WP 0040 00) and rotating back and forth.
2. Visually inspect the pump shaft **(3)** through the engine shroud **(4)** and ensure that the pump shaft **(3)** is also turning. There should not be any slippage of the flexible coupling **(5)** while turning the motor shaft **(1)**.
3. If the flexible coupling **(5)** is slipping on the pump shaft **(3)**, tighten the hex set screw **(6)** in the side of the flexible coupling **(5)**.
4. Repeat steps 1 through 3 until no more slippage is noted.

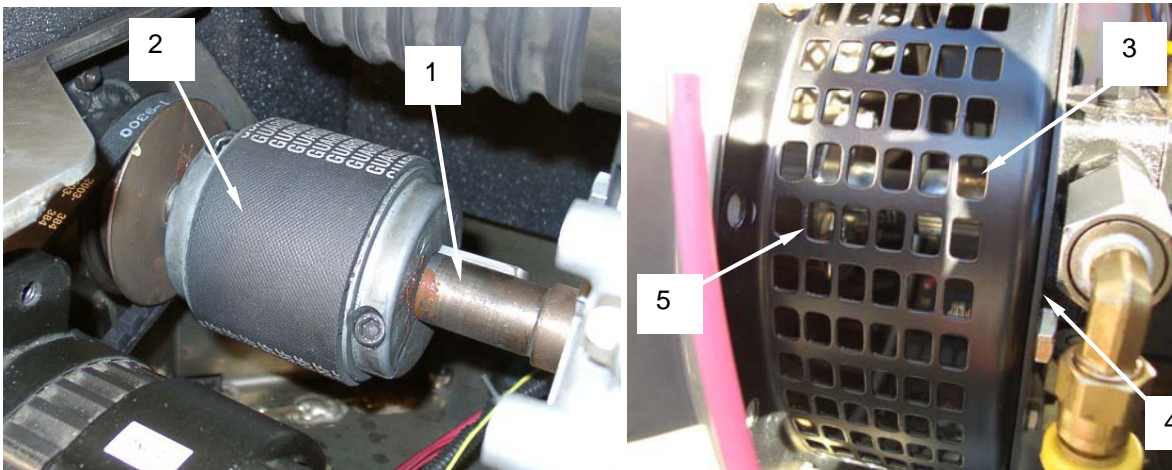

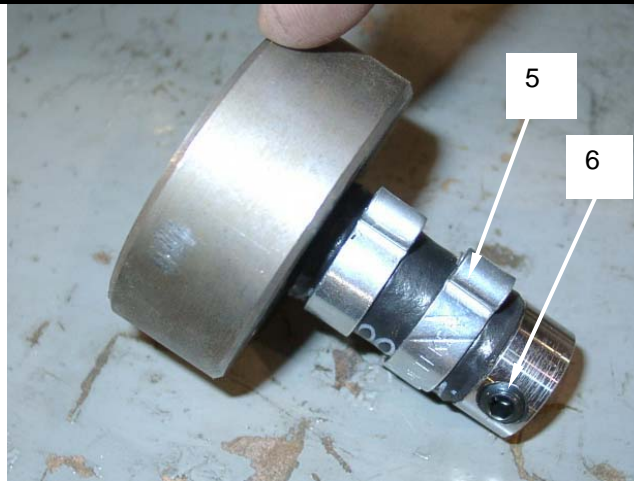
**REPLACE****WARNING**

Fuel is toxic. Be sure to place a petroleum absorbent mat or tray below the fuel pump to collect any fuel. Be sure to wipe up any spills with a rag.

1. Tag and mark all fuel hoses connected to burner fuel pump.
2. Loosen fitting (1) on fuel hose (2) and remove hose. Wipe up any spilled fuel with a rag.
3. Loosen fitting (3) on fuel hose (4) and remove hose. Wipe up any spilled fuel with a rag.
4. Loosen fitting (5) on fuel hose (6) and remove hose. Wipe up any spilled fuel with a rag.
5. Loosen fittings (7) on fuel hoses (8) connected to both sides of Tee fitting (9) and remove hose. Wipe up any spilled fuel with a rag.
6. Take note of orientation and remove Tee fitting (9). Clean any residual thread sealant and set aside.
7. Take note of orientation and remove fitting assembly (10) installed at burner fuel pump outlet (11). Clean any residual thread sealant and set aside.
8. Take note of orientation and remove shut off valve and elbow assembly (12). Clean any residual thread sealant and set aside.
9. Remove nuts (13) and lock washers (14) on either side of burner fuel pump (15) that secure it to the engine flywheel cover.
10. Loosen set screw (16) on pump drive coupling (17).
11. Remove defective burner fuel pump (15).
12. Install new burner fuel pump (15) by aligning shaft on pump drive coupling (17) with engine shaft protruding from flywheel cover. Note that shaft on pump drive coupling is "D" shaped

and will only engage with engine shaft when properly oriented. Tighten set screw when properly mounted.

13. Align holes **(18)** on burner fuel pump with studs **(19)** on engine flywheel cover **(20)**.
14. Install lock washers **(14)** and nuts **(13)** to studs **(19)** and tighten securely.

CAUTION

Do not apply thread sealant to threads of compression fitting.

15. Apply new thread sealant to threads of shut off valve and elbow assembly **(12)** and install at fuel inlet side **(21)** of burner fuel pump **(15)**. Do not apply thread sealant to elbow fitting threads.
16. Install shut off valve and elbow assembly **(12)** taking care to return it to orientation noted earlier. Tighten securely.
17. Apply thread sealant to threads of fitting assembly **(10)** that installs into burner fuel pump **(12)**. Install fitting assembly **(10)** into burner fuel pump port **(11)** taking care to return fitting assembly to orientation noted earlier.
18. Apply thread sealant to the threads of the Tee fitting **(9)** that will install into the burner pump outlet port. Do not apply thread sealant to threads of compression fittings for fuel hoses.
19. Install Tee fitting **(9)** into burner pump outlet port taking care to orient the fitting as noted earlier. Tighten securely but oriented properly.
20. Noting tags and markings made earlier, install fuel hoses **(8)** to both sides of Tee fitting **(9)**. Tighten fittings **(7)** securely.
21. Install fuel hose **(6)**. Install and tighten fitting **(5)** securely.
22. Install fuel hose **(4)**. Install and tighten fitting **(3)** securely.
23. Install fuel hose **(2)**. Install and tighten fitting **(1)**.
24. Remove all tags and/or markings.
25. Once the new burner fuel pump is installed, check and adjust the system fuel pressure IAW Adjustment paragraph in this work package.

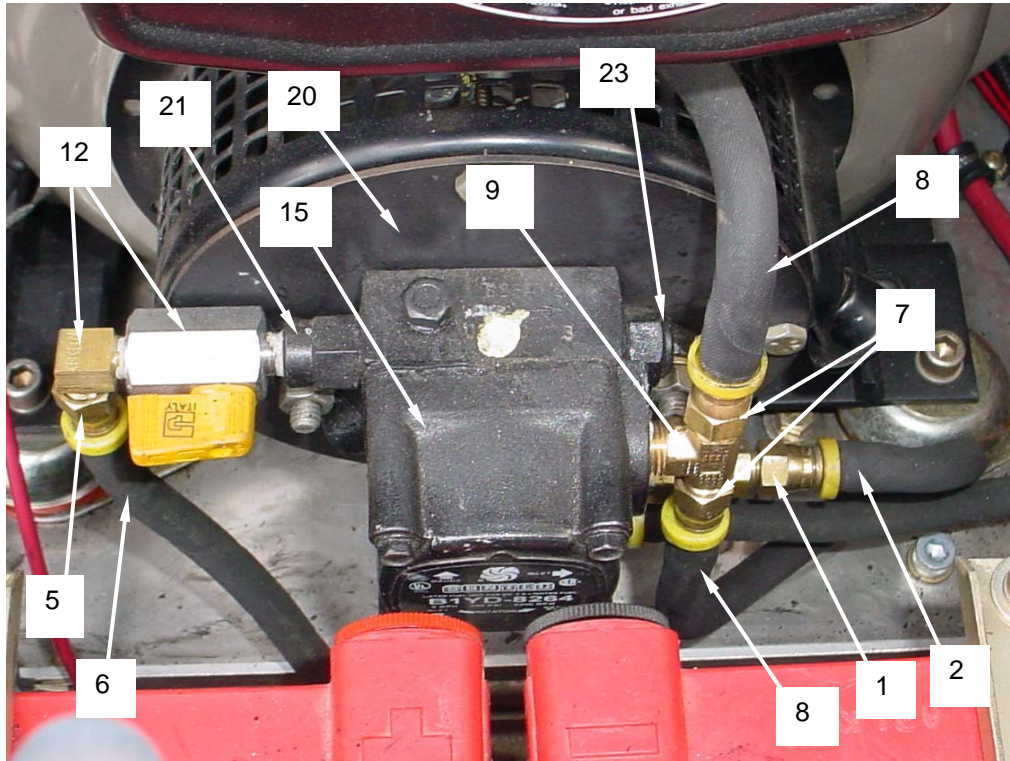

ADJUSTMENT

Adjust burner fuel pressure to match local altitude conditions. Excessive smoke observed DURING BURNER OPERATION (B-Lo and B-Hi) is reason to adjust fuel pressure. Excessive smoke observed during Vent mode indicates an engine problem such as a dirty or faulty fuel injector or a dirty air cleaner.

Low Altitude Adjustment (below 6000 feet)

1. Close all access panels except the burner access panel and start the LCFH in VENT mode as described in WP 0005 00.
2. Monitor the system pressure gauge (**22**) located inside the fuel access door and ensure that it reads 180 psi. If the system pressure is exactly 180 psi, no further action is required and the LCFH is ready for operation. If system pressure is not 180 psi, take note of whether the system pressure is greater than 180 psi or lower than 180 psi.
3. Shut the heater down and wait for the shut down sequence to complete. Place the main battery shut down in the OFF position and remove the handle. Open the engine access panel.

**WARNING**

Do not attempt the burner fuel pump system pressure adjustment with the heater running. Attempting to perform this procedure with heater running may result in severe injury to personnel.

4. Adjust the burner fuel pump pressure adjustment screw **(23)** as follows:

NOTE

The fuel pressure adjusting screw is a horizontally aligned screw on the back of the fuel pump and will not be easily visible unless the top engine cover is removed. In the illustration above, the top engine cover has been removed for clarity, but it is not necessary to remove it for adjustment purposes.

Turn the adjustment screw no more than 1/4-turn clockwise or counterclockwise in each adjustment attempt.

- a. If the system pressure monitored in step 2 was less than 180 psi, rotate the adjustment screw clockwise to increase system pressure.
 - b. If the system pressure monitored in step 2 was greater than 180 psi, rotate the adjustment screw counterclockwise to decrease system pressure.
5. After making the necessary adjustment, place the main battery shutdown switch in the ON position and close all access panels except the burner access panel. Start the LCFH and monitor the system pressure as detailed in step 2. Ensure that system pressure is 180 psi. If it is not, perform steps 2 through 5 as necessary until a system pressure of 180 psi is reached.

High Altitude Adjustment (6000 feet or above)

At altitudes above 6000 feet, excessive smoke may be seen in the exhaust, and it may be necessary to reduce the burner fuel pressure to facilitate proper burner operation. Do not adjust the burner fuel pump pressure if excessive smoke is not being emitted in the exhaust. Do not reduce the system fuel pressure any more than is necessary to eliminate the excessive smoke and do not reduce the fuel pressure to a setting below 120 psi under any condition.

If excessive burner smoke is present during high altitude operation (6000 feet or above), perform the following steps:

**WARNING**

Do not attempt the burner fuel pump system pressure adjustment with the heater running. Attempting to perform this procedure with heater running may result in severe injury to personnel.

1. If running, shut the heater down and wait for the shut down sequence to complete. Place the main battery shut down in the OFF position and remove the handle. Open the engine access door.

NOTE

The fuel pressure adjusting screw is a horizontally aligned screw on the back of the fuel pump and will not be easily visible unless the top engine cover is removed. In the illustration above, the top engine cover has been removed for clarity, but it is not necessary to remove it for adjustment purposes.

2. To reduce the fuel pressure, adjust the burner fuel pump pressure adjustment screw **(23)** no more than 1/4-turn counterclockwise per adjustment.
3. Close all access panels/doors except the burner access panel and start the LCFH in MANUAL mode as described in WP 0005 00. The LCFH must be in either B-Lo or B-Hi to check for smoke.
4. Visually check exhaust for evidence of excessive smoke. If no smoke exists, no further adjustments need to be made. If excessive smoke exists, repeat steps 1 through 4 until excessive smoke is no longer present.
5. Be sure to reset the fuel pressure back to 180 psi when operating at altitudes below 6000 feet IAW Low Altitude Adjustment (below 6000 feet) paragraph of this work pack.

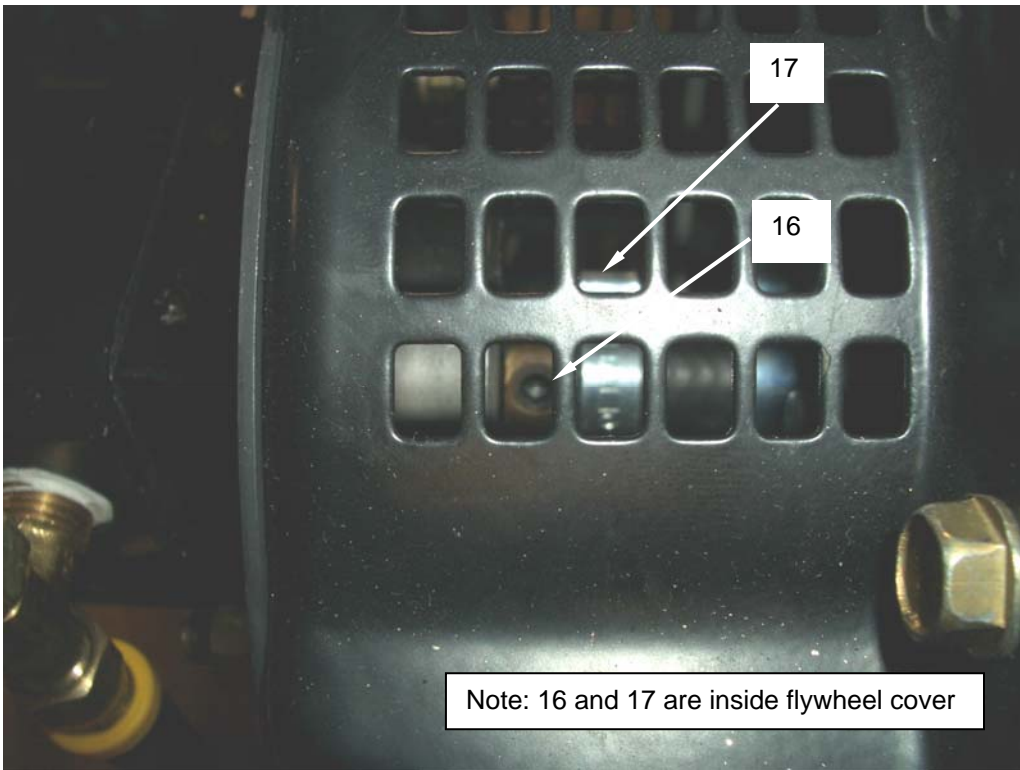
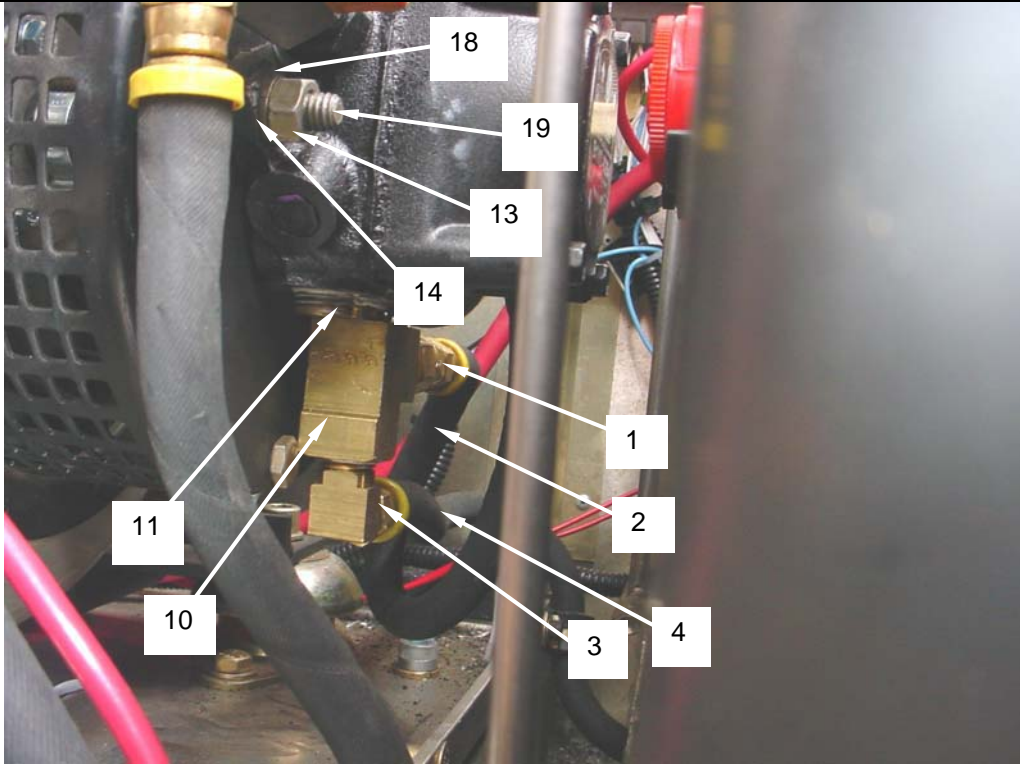

System Pressure should be set to 180 psi at altitudes below 6000 ft.

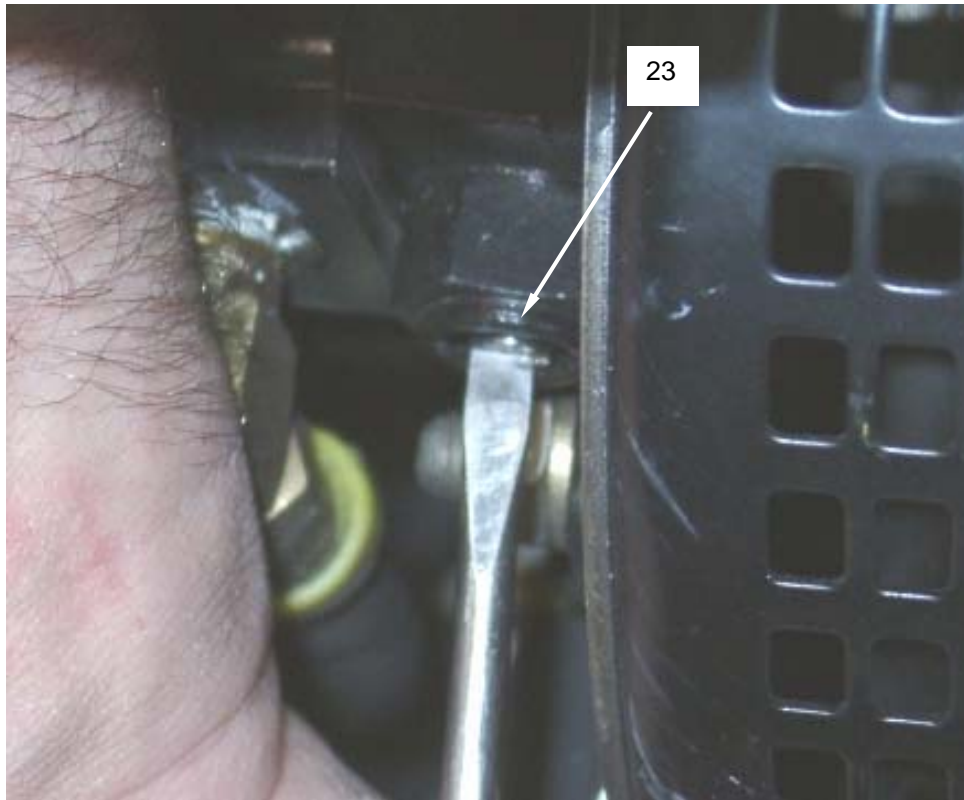
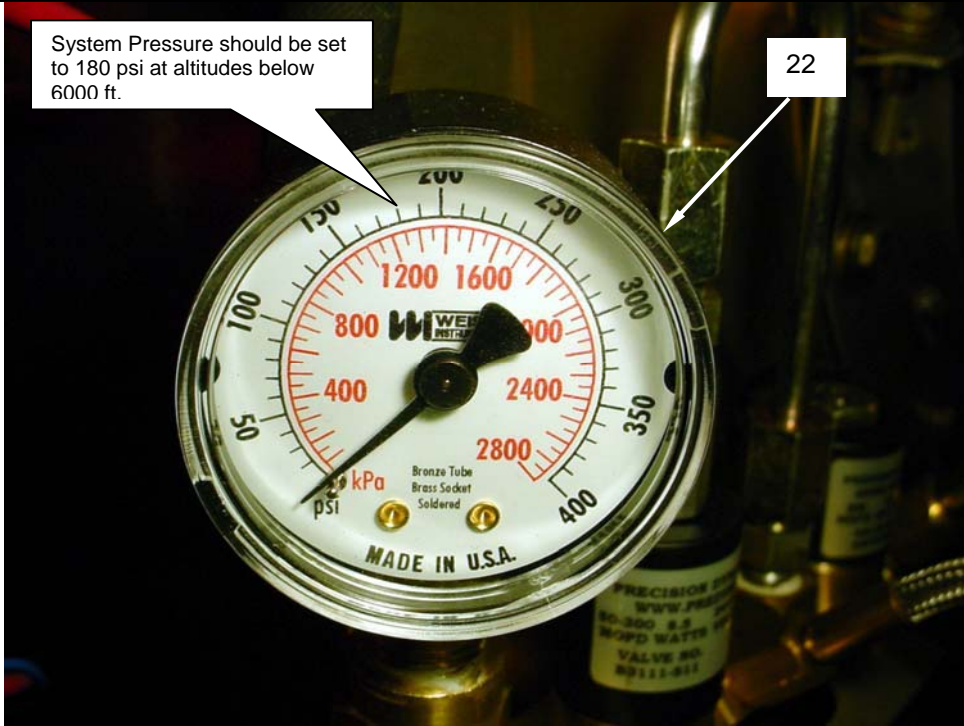

END OF WORK PACKAGE

Change 1

0033 00-8

FIELD (UNIT) MAINTENANCE**LARGE CAPACITY FIELD HEATER****NSN 4520-01-500-1534****FUEL TANK
SERVICE, REPLACE**

INITIAL SETUP:**Tools**

Tool Kit, General Mechanics (Item 2, WP 0092 00)

Personnel Required

MOS 63J or 52C

Materials/Parts

Mat, Petroleum Absorbent (Item 8, WP 0119 00)

Equipment ConditionHeater shut down and cool (WP 0005 00)
Main Battery Power Switch in the OFF position
and handle removed

SERVICE**NOTE**

If the tank has a significant amount of fuel, it should be pumped or siphoned off into an approved container through the fuel filler port.

1. To drain all accumulated water from fuel tank, ensure that the tank is down to approximately one or two gallons of fuel.
2. Ensure that LCFH is positioned so that the fuel tank drain **(1)** located on the underside of the heater just below the fuel filler port and fuel gauge area is slightly downgrade to permit proper draining.
3. Place an approved, appropriated sized container under the fuel drain **(1)**.
4. Remove the drain plug **(2)** from fuel tank and drain until empty.
5. When empty, install drain plug **(2)** and tighten securely.
6. Dispose of fuel according to unit SOP and local environmental regulations. Do not return fuel to the bulk fuel container.

**REPLACE****WARNING**

Fuel is toxic. Be sure to place a petroleum absorbent mat or tray below the fuel pump to collect any fuel. Be sure to wipe up any spills with a rag.

1. Remove heater end panel and external fuel hose at fuel filler cap end of heater. Set panel and hardware aside.
2. Drain the fuel tank **(1)** completely into an approved container. Ensure that petroleum absorbent mats are placed under the heater to catch any fuel that may spill.
3. Release the quick release mechanisms on the two fuel tank mounting straps **(2)** in order to free the fuel tank **(1)** from the fuel tank mounting plate **(3)**.
4. Locate the tank vent hose **(4)**, fuel supply hose **(5)**, and fuel return hose **(6)**.
5. Tag each hose as to its function and location.
6. Loosen and remove the fittings securing hoses, and remove hoses.
7. Disconnect the fuel tank level switch wire harness connector **(7)**.
8. Lift fuel tank **(1)** and slide out through the rear of the heater.
9. Discard the defective fuel tank in an approved manner.

10. Install a new fuel tank (1) by positioning the tank on the fuel tank mounting plate between the mounting straps (2).
11. Engage the two straps (2) and lock the two quick release mechanisms.
12. Connect the fuel hoses (4, 5, and 6) to the new fuel tank (1) as tagged, and tighten fittings.
13. Connect the fuel tank level switch wire harness connector (7).
14. Install external fuel hose on connector, and then install heater end panel.

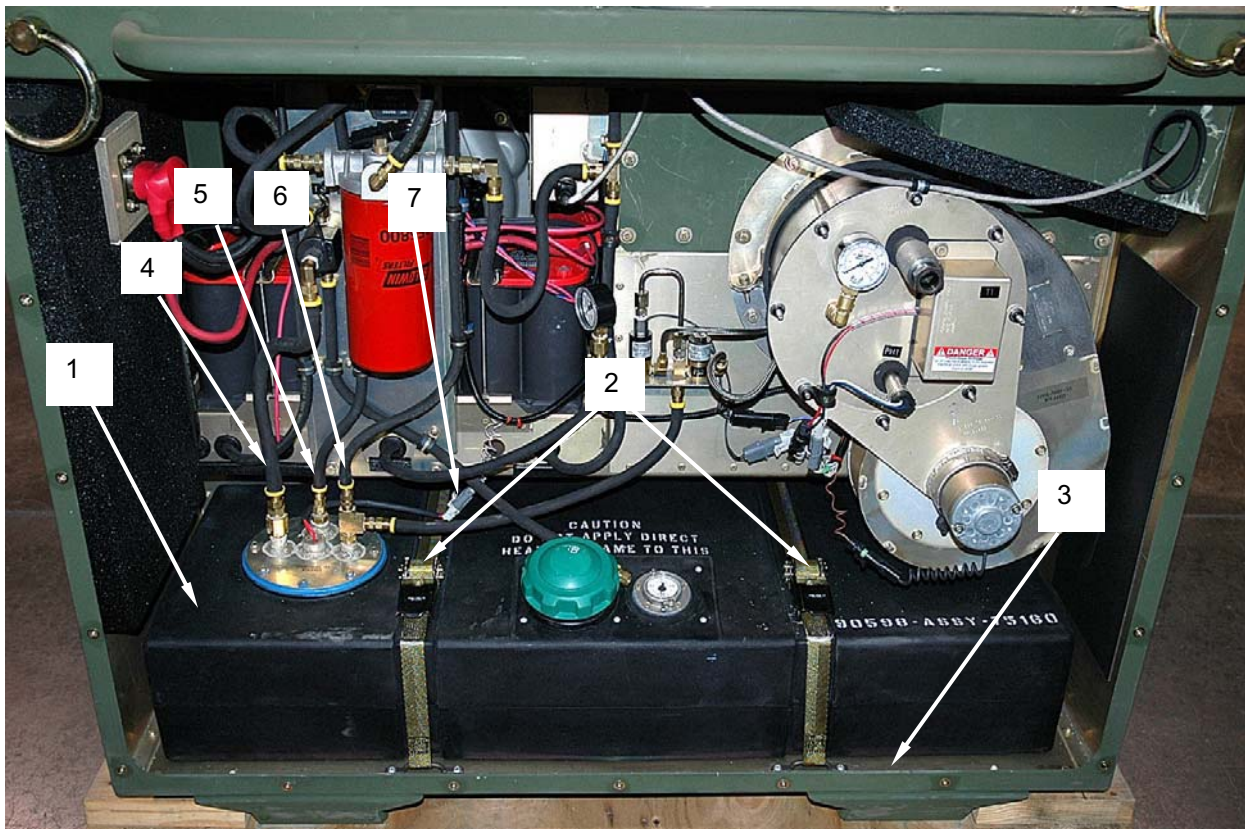

END OF WORK PACKAGE

FIELD (UNIT) MAINTENANCE

LARGE CAPACITY FIELD HEATER

NSN 4520-01-500-1534

FUEL TANK LEVEL SWITCH
REPLACE

INITIAL SETUP:

Tools

Tool Kit, General Mechanics (Item 2, WP 0092 00)

Personnel Required

MOS 63J or 52C

Materials/Parts

None required

Equipment Condition

Heater shut down and cool (WP 0005 00)
Main Battery Power Switch in the OFF position
and handle removed.

REPLACE

**WARNING**

Fuel is toxic. Be sure to place a petroleum absorbent mat or tray below the fuel pump to collect any fuel. Be sure to wipe up any spills with a rag.

1. Drain the fuel tank **(1)** completely into an approved container. Ensure that petroleum absorbent mats are placed under the heater to catch any fuel that may spill.
2. Tag and/or mark each of the fuel hoses and their respective locations.
3. Loosen the fitting **(2)** and remove the tank vent hose **(3)**.
4. Loosen the fitting **(4)** and remove the fuel pickup to remote/external solenoid hose **(5)**.
5. Loosen the fitting **(6)** and remove the return from fuel filter hose **(7)**.
6. Loosen fitting **(8)** and remove return from burner solenoid hose **(9)**.
7. Disconnect fuel tank level switch connector **(10)**.
8. Remove the ten screws **(11)** and lockwashers **(12)** that secure the fuel tank level switch assembly **(13)** to the fuel tank **(1)**. Set the hardware aside.
9. Note the orientation of the fuel tank level switch assembly **(13)** so that the new assembly can be installed in the same position. Remove the defective fuel tank level switch assembly **(13)**.
10. Install a new fuel tank level switch assembly **(13)** so that the assembly is oriented as noted earlier. Align the holes in the assembly with the captive fasteners **(14)** in the fuel tank **(1)**.

11. Install the ten screws (11) and lockwashers (12) that secure the fuel tank level switch assembly (13) to the fuel tank (1). Tighten all hardware securely.
12. Connect fuel tank level switch connector (10).
13. Install return from burner solenoid hose (9) on fuel tank level switch assembly fitting (15). Tighten fitting (8) securely.
14. Install remove the return from fuel filter hose (7) on fuel tank level switch assembly fitting (16). Tighten fitting (6) securely.
15. Install fuel pickup to remote/external solenoid hose (5) on fuel tank level switch assembly fitting (17). Tighten fitting (4) securely.
16. Install tank vent hose (3) on fuel tank level switch assembly fitting (18). Tighten fitting (2) securely.
17. Remove all tags and/or markings.

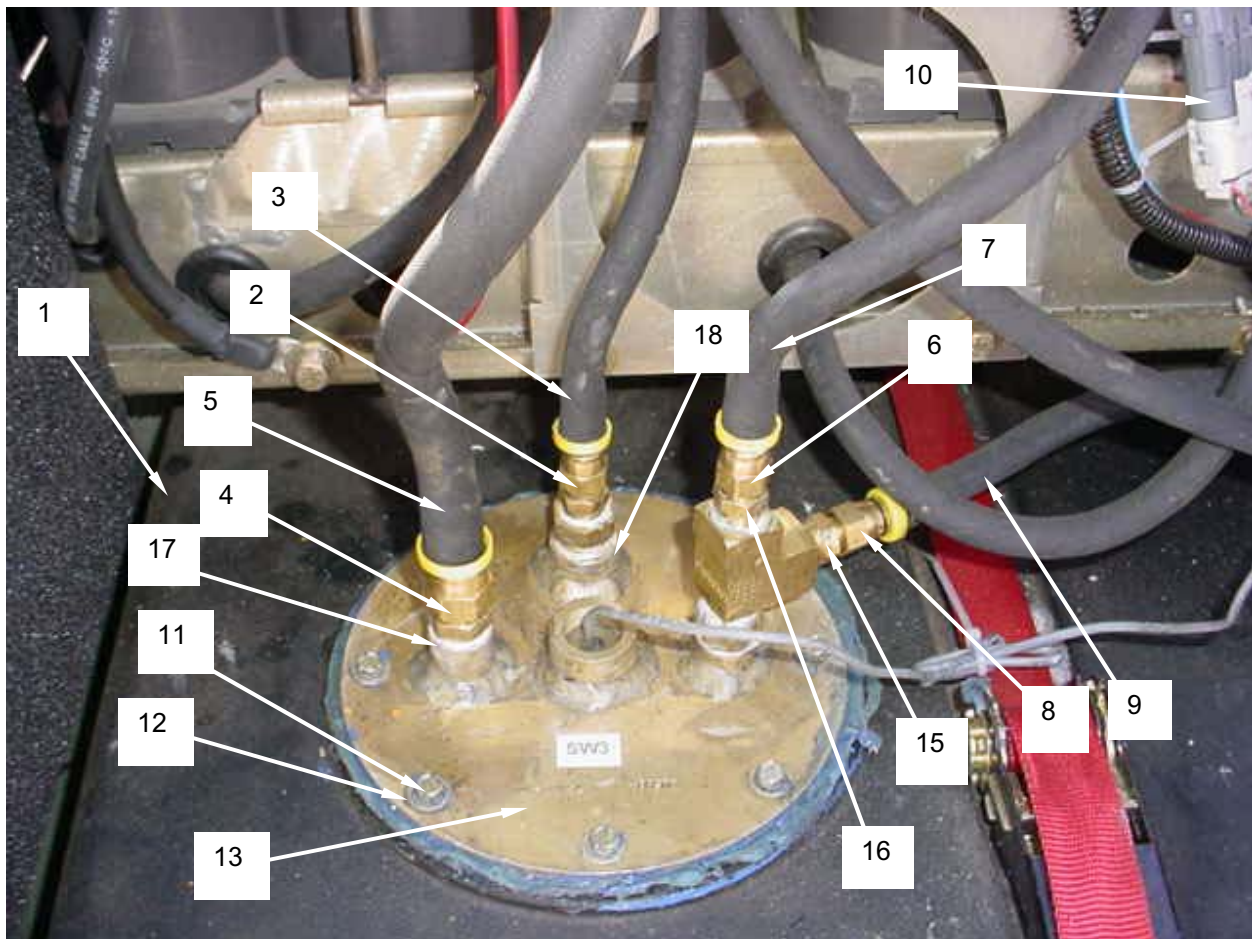

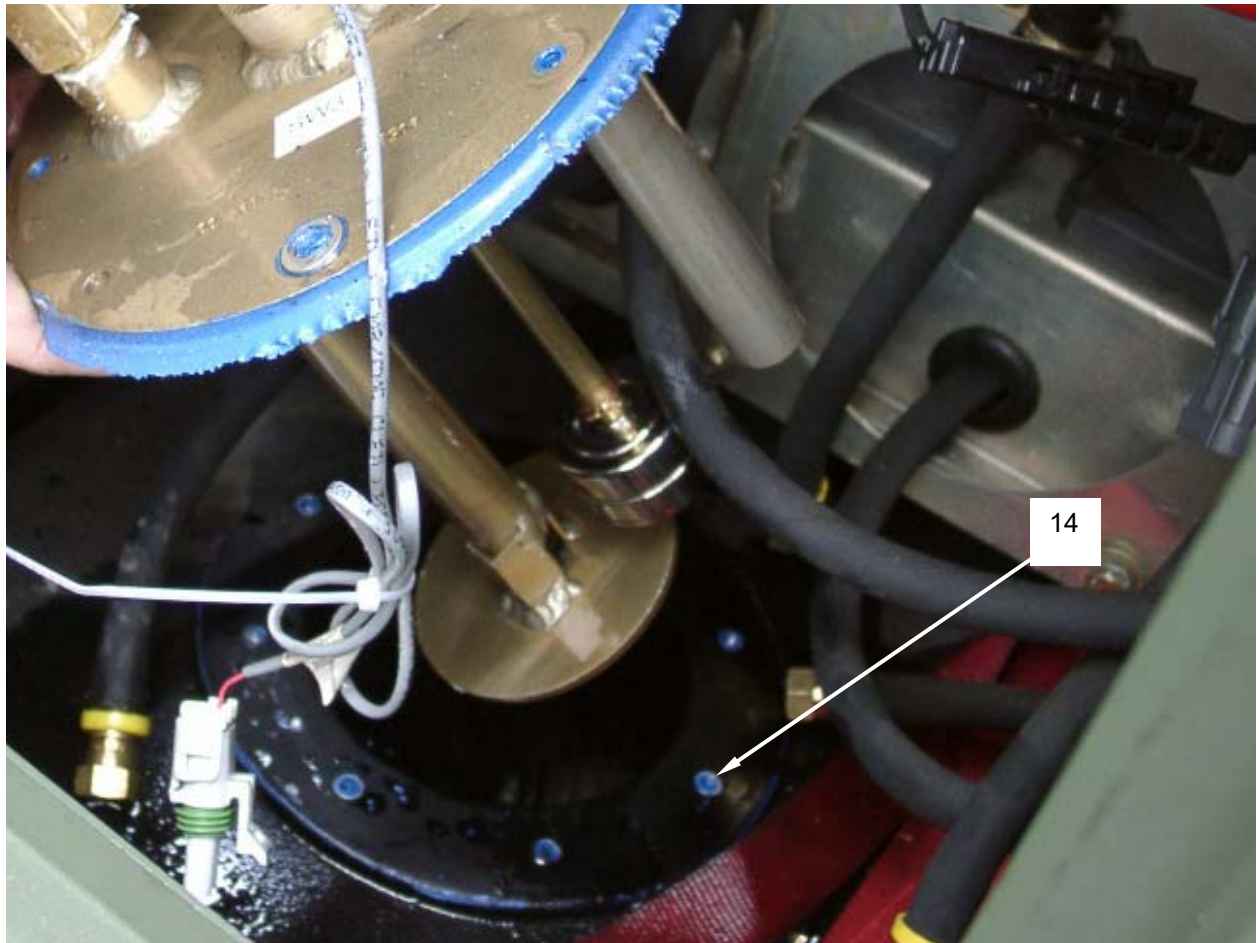

END OF WORK PACKAGE

FIELD (UNIT) MAINTENANCE
LARGE CAPACITY FIELD HEATER (LCFH)

NSN 4520-01-500-1534

**EXTERNAL FUEL SUPPLY CONNECTOR
INSPECT, REPLACE**

INITIAL SETUP:**Tools**

Tool Kit, General Mechanics (Item 2, WP 0092 00)

Personnel Required

MOS 63J or 52C

Materials/Parts

Rag, wiping, clean (Item 4, WP 0119 00)
Sealant, Thread (Item 2, WP 0119 00)

Equipment Condition

Heater shut down and cool.
Main battery switch OFF and handle removed.

INSPECT

Inspect the external fuel supply connector **(1)** and ensure that it is not damaged in any way. Ensure that there is no dust, dirt, or other debris on the interior or exterior surfaces. Ensure that the outer collar **(2)** operates smoothly and springs back correctly.

REPLACE

1. Remove the external fuel supply connector **(1)** by placing a wrench or similar tool on the large hex shaped fitting **(3)** mounted to the cabinet **(4)**.
2. While holding the large hex shaped fitting **(3)** section stationary, grasp the hex shaped section **(5)** at the rear of the connector with a wrench or similar tool and rotate counter clockwise. Remove the connector **(1)**.
3. Clean any residual thread sealant from the threads on the large hex shaped fitting **(3)**.
4. Apply new thread sealant to the threads of the large hex shaped fitting **(3)**.
5. Install a new external fuel supply connector **(1)** onto the large hex shaped fitting **(3)**.
6. While holding the large hex shaped fitting **(3)** stationary, grasp the hex shaped section **(5)** at the rear of the connector with a wrench or similar tool and rotate clockwise. Tighten securely.

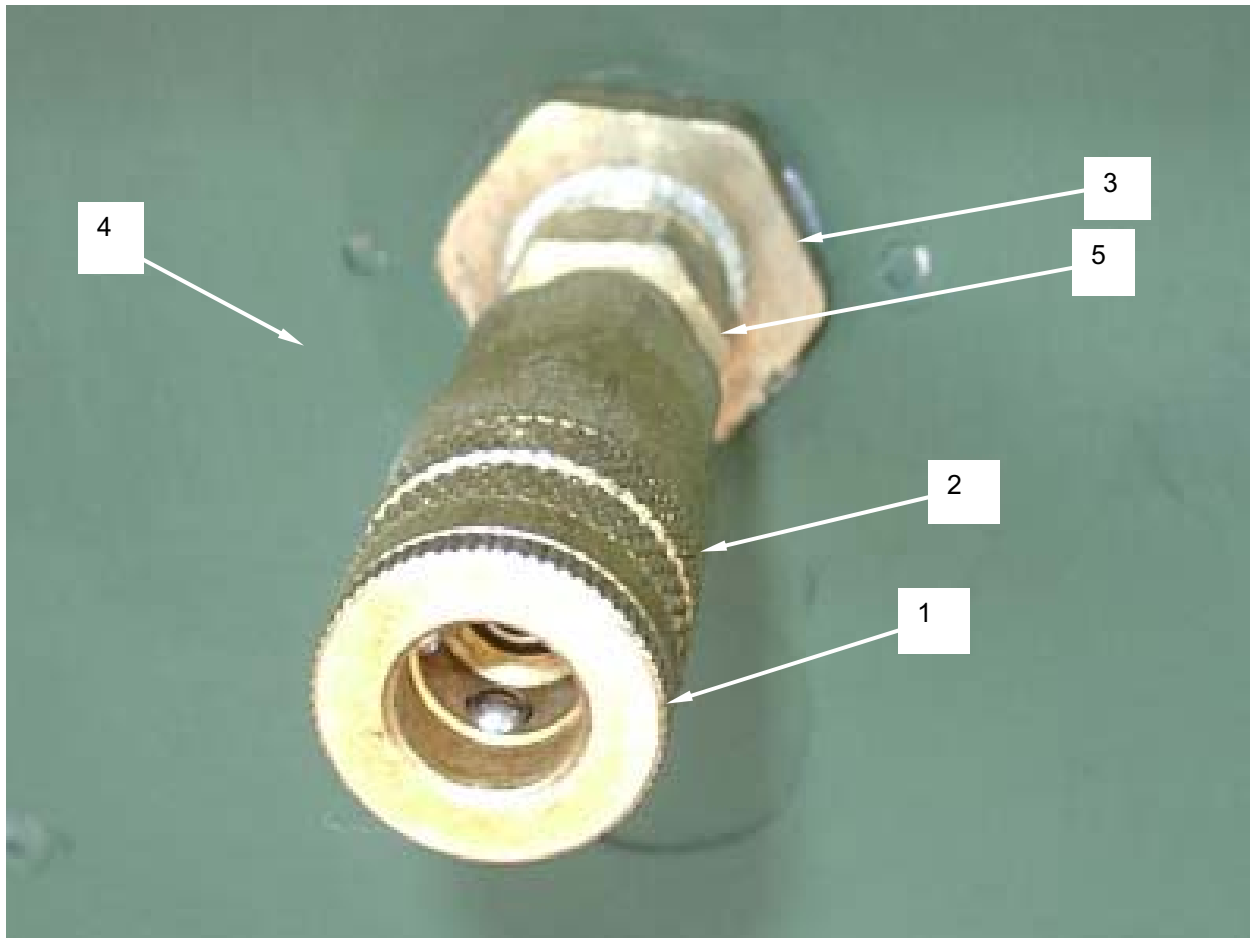

END OF WORK PACKAGE

FIELD (UNIT) MAINTENANCE**LARGE CAPACITY FIELD HEATER (LCFH)****NSN 4520-01-500-1534****SAFETY SCREEN
INSPECT, REPLACE**

INITIAL SETUP:**Tools**Tool Kit, General Mechanics (Item 2, WP 0092
00)**Personnel Required**

MOS 63J or 52C

Materials/Parts

None required

Equipment ConditionHeater shut down and cool.
Main battery switch OFF and handle removed.

INSPECT

Inspect the safety screens **(1 and 2)** at the inlet **(3)** and outlet **(4)** duct housings and ensure that they are present and are not damaged in such a way as to make it possible to get a hand or other limb into the inlet or outlet duct during operation.

REPLACE**NOTE**

The inlet and outlet duct safety screens are identical. The replacement procedure for both is the same.

1. Remove the four nuts **(5)** and lock washers **(6)** that secure the screen **(1)** to the duct housing **(7)**.
2. Remove the defective safety screen **(1)**.
3. Install a new safety screen **(1)** by aligning the holes in the screen with the holes on the duct housing **(7)**.
4. Install four nuts **(5)** and lock washers **(6)**. Tighten securely.

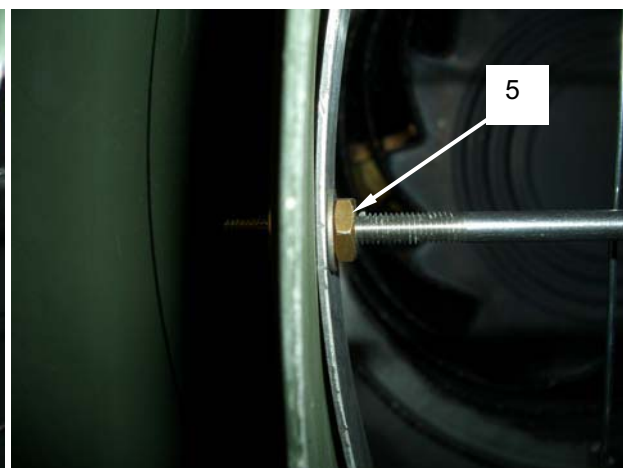
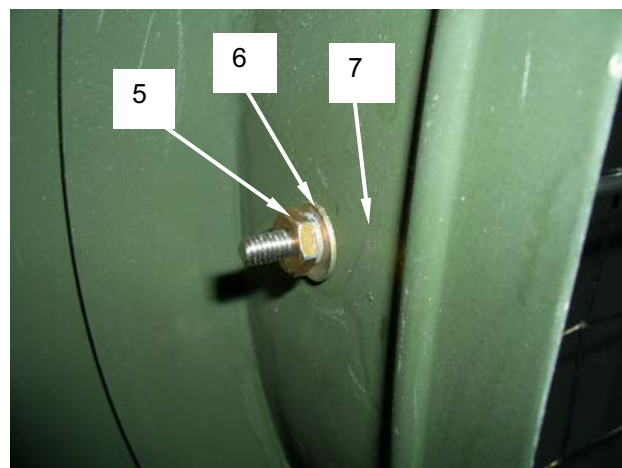
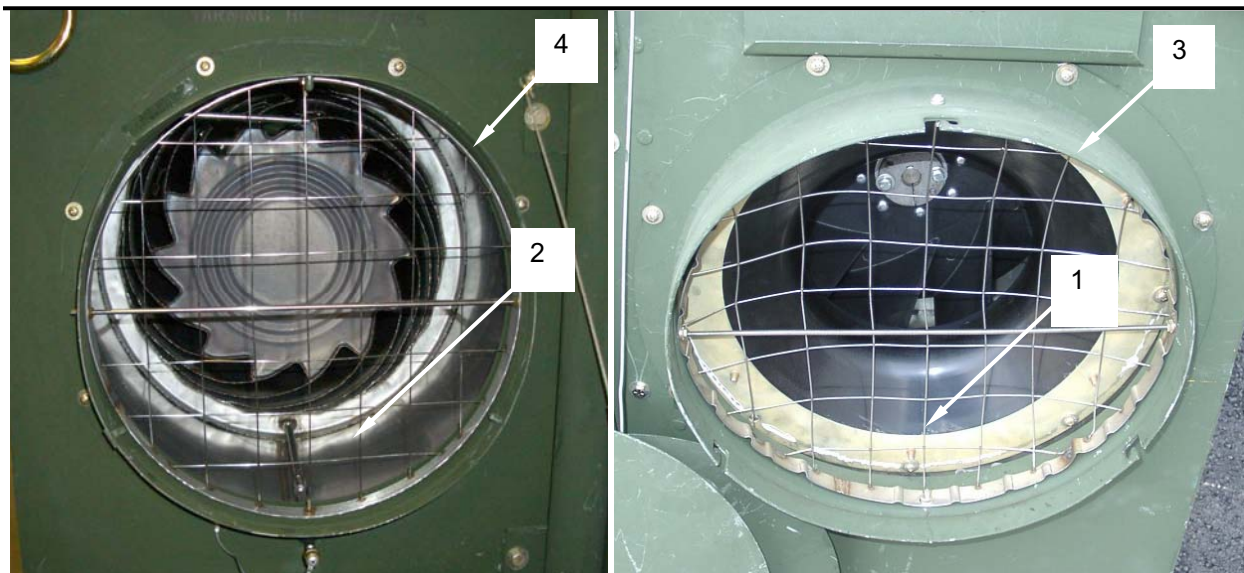

END OF WORK PACKAGE

FIELD (UNIT) MAINTENANCE

LARGE CAPACITY FIELD HEATER

NSN 4520-01-500-1534

INLET FAN ASSEMBLY
REPLACE

INITIAL SETUP:

Tools

Tool Kit, General Mechanics (Item 2, WP 0092 00)

Personnel Required

MOS 63J or 52C

Materials/Parts

None required

Equipment Condition

Heater shut down and cool (WP 0005 00)
Main Battery Power Switch in the OFF position
and handle removed

REPLACE

1. Remove the bolt-on duct inlet collar **(1)** by removing eight screws **(2)**, lock washers **(3)**, and flat washers **(4)**. The safety screen **(5)** mounted in the collar can remain installed. Set bolt-on duct inlet collar and mounting hardware aside.
2. Remove the fan inlet cone **(6)** by removing the eight screws **(7)**, lock washers **(8)**, and flat washers **(9)**. Set inlet cone and mounting hardware aside.
3. Remove the two bolts **(10)** from the fan QD hub **(11)**.
4. Thread the bolts **(10)** into the "remove" holes **(12)** in the QD hub **(11)**. Note that these screws work like jack screws to break it loose from the fan and shaft.
5. Tighten bolts **(10)** evenly while threaded into "remove" holes **(12)** until the fan **(13)** breaks loose from the shaft. Be sure that nuts **(14)** on rear side of fan assembly remain installed.
6. Insert QD hub inside fan assembly and thread the bolts into the "retaining" holes.
7. Install new fan **(13)** in position. Be sure that only ¼ inch of shaft protrudes through QD hub. Do not push fan all the way onto shaft.
8. Install the two bolts **(10)** into the "retaining" holes **(15)** on the fan QD hub **(11)**. Tighten securely.
9. Install the fan inlet cone **(6)** and align so that it does not rub on the fan (holes are over-sized).
10. Secure the fan inlet cone **(6)** with screws **(7)**, lock washers **(8)**, and flat washers **(9)**.
11. Install the bolt-on duct inlet collar **(1)** and secure with screws **(2)**, lock washers **(3)**, and flat washers **(4)**. Ensure that the bar that spans the inlet collar is parallel with the top of the heater.

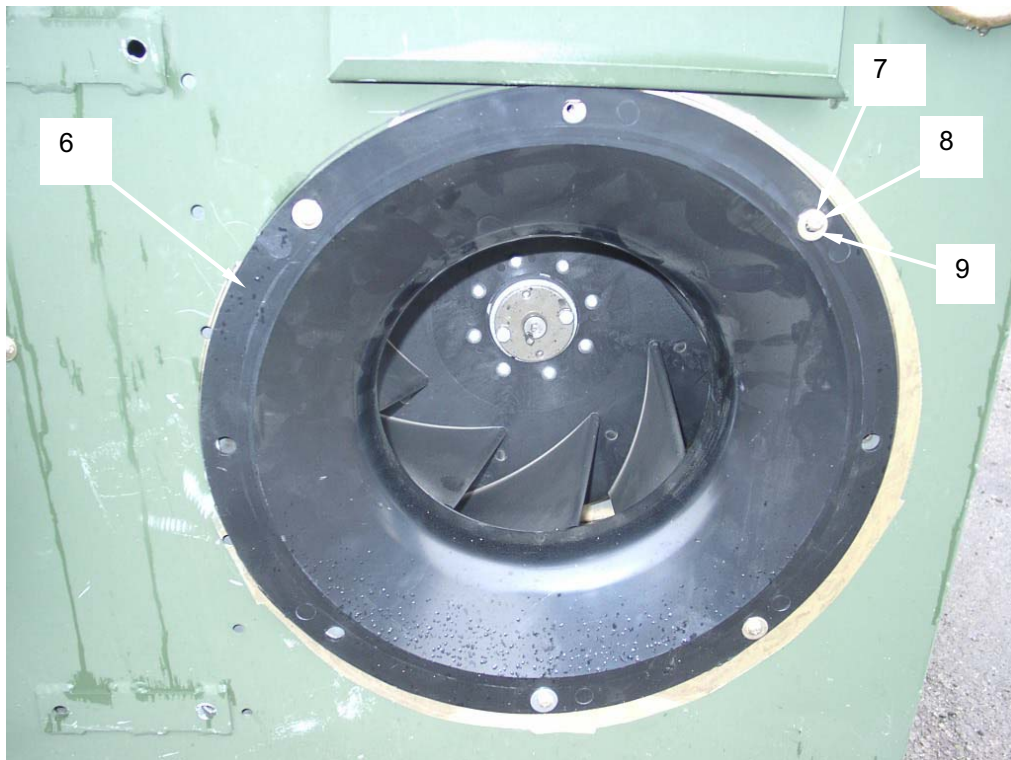

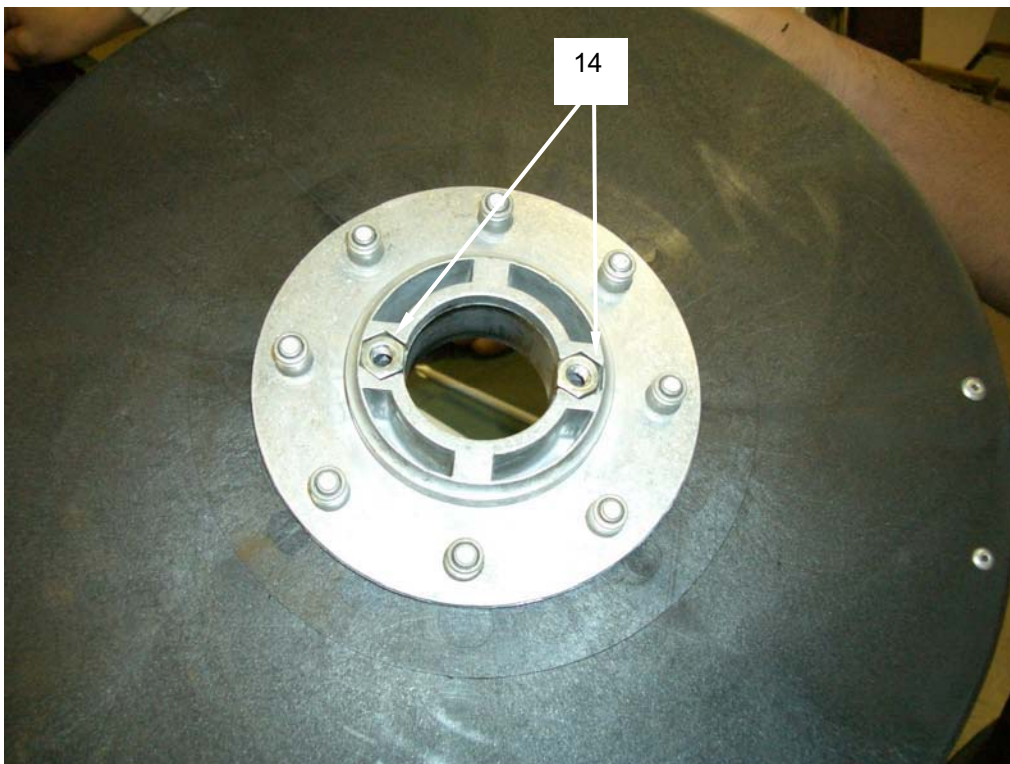
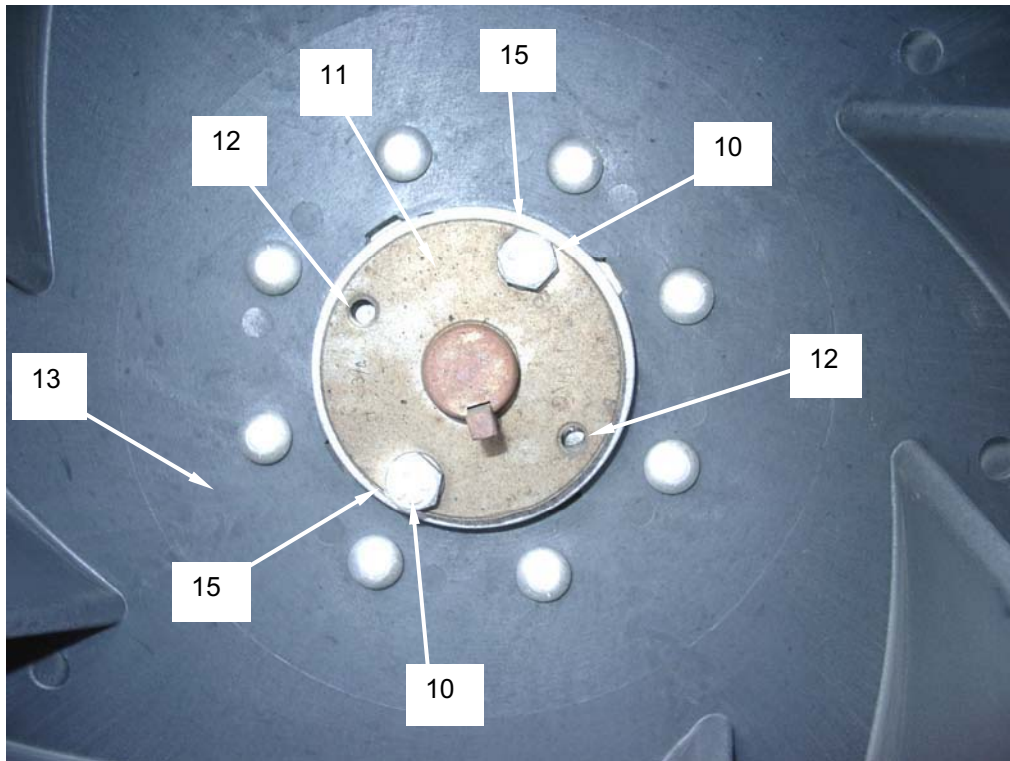

END OF WORK PACKAGE

0038 00-3/(4 Blank)

FIELD (UNIT) MAINTENANCE**LARGE CAPACITY FIELD HEATER**

NSN 4520-01-500-1534

**24V ALTERNATOR ASSEMBLY WITH PULLEY
INSPECT, TEST, ADJUST, REPLACE**

INITIAL SETUP:**Tools**

Tool Kit, General Mechanics (Item 2, WP 0092 00)

Personnel Required

MOS 63J or 52C

Materials/Parts

Tags, marking, MIL-T-12755 (Item 5, WP 0119 00)

Equipment Condition

Heater shut down and cool (WP 0005 00) except during TEST function
Main Battery Power Switch in the OFF position and handle removed except during TEST function
Engine bay access door open except during TEST function
Negative battery cable closest to engine bay access door removed from battery when performing INSPECT, ADJUST, or REPLACE functions.

INSPECT

1. Inspect the alternator belt (1) for damage or wear. Replace as required IAW procedures detailed in section of this work package entitled REPLACE BELT.
2. Ensure that the alternator belt (1) is not loose, slipping, or can be deflected more than 1/4 inch up or down. If alternator belt requires adjustment, re-tension belt in accordance with section of this work package entitled ADJUST.

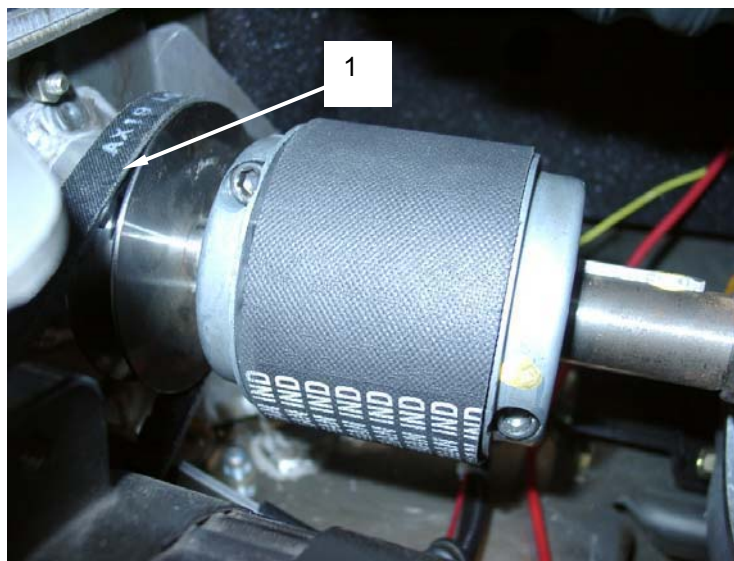

TEST

1. With the heater off, place the positive (+) lead of a multimeter on the center terminal **(1)** of the slave receptacle **(2)** and the negative lead (-) on the outer metal housing **(3)**. Make note of the voltage measured. The voltage displayed is the true condition of the batteries charge. The voltage measured should be very close to 24 VDC.
2. Ensure that all access doors are closed and start the heater. The main control board will delay the charging until the engine is warmed up; therefore, there will be a delay of approximately 15 seconds.

NOTE

The main control board in the heater is designed to monitor the engine RPM. If the main control board senses that the engine is loaded down and is slowing in RPM, the main control board first disables the charging system for 60 seconds to conserve engine RPM. After the 60 seconds, the main control board will enable the charging system and perform an internal test to determine if the engine can handle the load. If the engine can handle the load, the main control board will leave it enabled. All voltage measurements need to be viewed with this understanding.

3. After the engine starts, wait approximately 15 seconds and measure the voltage on the batteries via the slave receptacle **(2)** as detailed in step 1. If the batteries require charging, the voltage as measured at the slave receptacle **(2)** will slowly increase from the voltage that was measured with the heater OFF and noted in step 1. If the voltage increases as described, the alternator is operating properly. Alternatively, if the batteries are fully charged, the voltage would jump (after the 15 seconds) immediately to approximately 28 VDC which would indicate that the alternator is operating properly.
4. Replace the alternator as detailed in the section of this work package entitled REPLACE if the alternator is not operating within operational limits as described in the previous two steps.

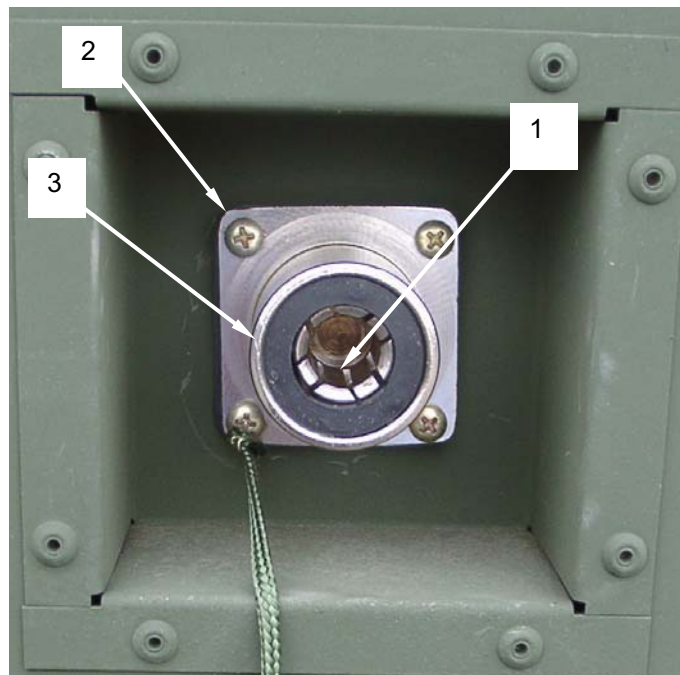

0039 00-2

ADJUST**WARNING**

Disconnect the negative battery terminal on the battery closest the engine bay access door before performing maintenance involving the alternator. Note that power is still applied to the alternator even when the main battery shutdown switch is in the OFF position. Failure to disconnect battery terminal may result in shock or other serious injury.

NOTE

Use of the pry bar in the general mechanics tool kit is recommended for the adjustment of the alternator belt.

1. To retension the alternator belt **(1)**, loosen the two bolts **(2)** that maintain tension on the alternator belt. Do not remove bolts.
2. Place a pry bar between the alternator **(3)** and the engine mounting bracket **(4)** and apply pressure to the alternator so as to tension the belt **(1)**. When there is no more than 1/4 inch of up and down deflection in the belt, tighten the two tensioning bolts **(2)**.

REPLACE BELT

1. Loosen alternator and remove tension from belt as described in the section of this work package entitled ADJUST.
2. Remove the rubber center portion of the flexible coupler as described in WP 0040 00.
3. Remove defective alternator belt.
4. Install new alternator belt, engaging the belt on the alternator and the fan drive pulley.
5. Install rubber center portion of the flexible coupler as described in WP 0040 00. Be sure to allow a 1/8 inch gap between the right side of the rubber center portion of the flexible coupler and the left rim of the right flexible coupler flange.
6. Tension new alternator belt as described in the section of this work package entitled ADJUST.

REPLACE ALTERNATOR**WARNING**

Disconnect the negative battery terminal on the battery closest the engine bay access door before performing maintenance involving the alternator. Note that power is still applied to the alternator even when the main battery shutdown switch is in the OFF position. Failure to disconnect battery terminal may result in shock or other serious injury.

1. Tag the wires on the rear of the alternator **(3)** as to their location and function.

2. Disconnect the D+ regulator trio terminal **(5)**, excitation terminal **(6)**, A/C terminal **(7)**, negative output terminal **(8)**, and positive output terminal **(9)**.
3. Remove top tensioning bolt **(2)** and loosen lower bolt to relieve the belt tension on the alternator **(3)**.
4. Remove the belt **(1)** from the alternator pulley **(10)**.

NOTE

To improve access to the alternator, it is suggested that the end of the engine air intake hose connected to the engine be removed and pushed off to the side.

NOTE

To ease removal of the lower bolt, it is suggested that a ratchet and socket be used on the head of the bolt and a box end wrench be used to hold the nut on the opposite side in place.

5. Remove the bolt **(2)** and nut **(11)** at the base of the alternator **(3)** and remove the defective alternator by first backing the alternator away from the mounting plate and rotating the alternator 90 degrees so that the pulley faces the engine access bay opening. Pull the alternator straight out of the engine access bay.
6. Install a new alternator **(3)** by inserting the back of the alternator first and rotating the pulley end of the alternator 90 degrees into position on the mounting plate. Align the hole **(12)** at the base of the alternator with the hole **(13)** in the alternator mounting bracket.
7. Install the bolt **(2)** and lock nut **(11)** at the base of the alternator **(3)**. Do not tighten securely at this time.
8. Swing the alternator **(3)** up into position and install the alternator belt **(1)** on the alternator pulley **(10)**.
9. Install the top tensioning bolt **(2)** but do not tighten completely at this time.
10. Place a pry bar between the alternator **(3)** and the engine mounting bracket **(4)** and apply pressure to the alternator so as to tension the belt. When there is no more than 1/4 inch of deflection in the belt, tighten the two tensioning bolts **(2)**.
11. Connect the D+ regulator trio terminal **(5)**, excitation terminal **(6)**, A/C terminal **(7)**, negative output terminal **(8)**, and positive output terminal **(9)** as tagged earlier.
12. Remove all tags and markings.
13. Reinstall engine air intake hose if removed earlier.

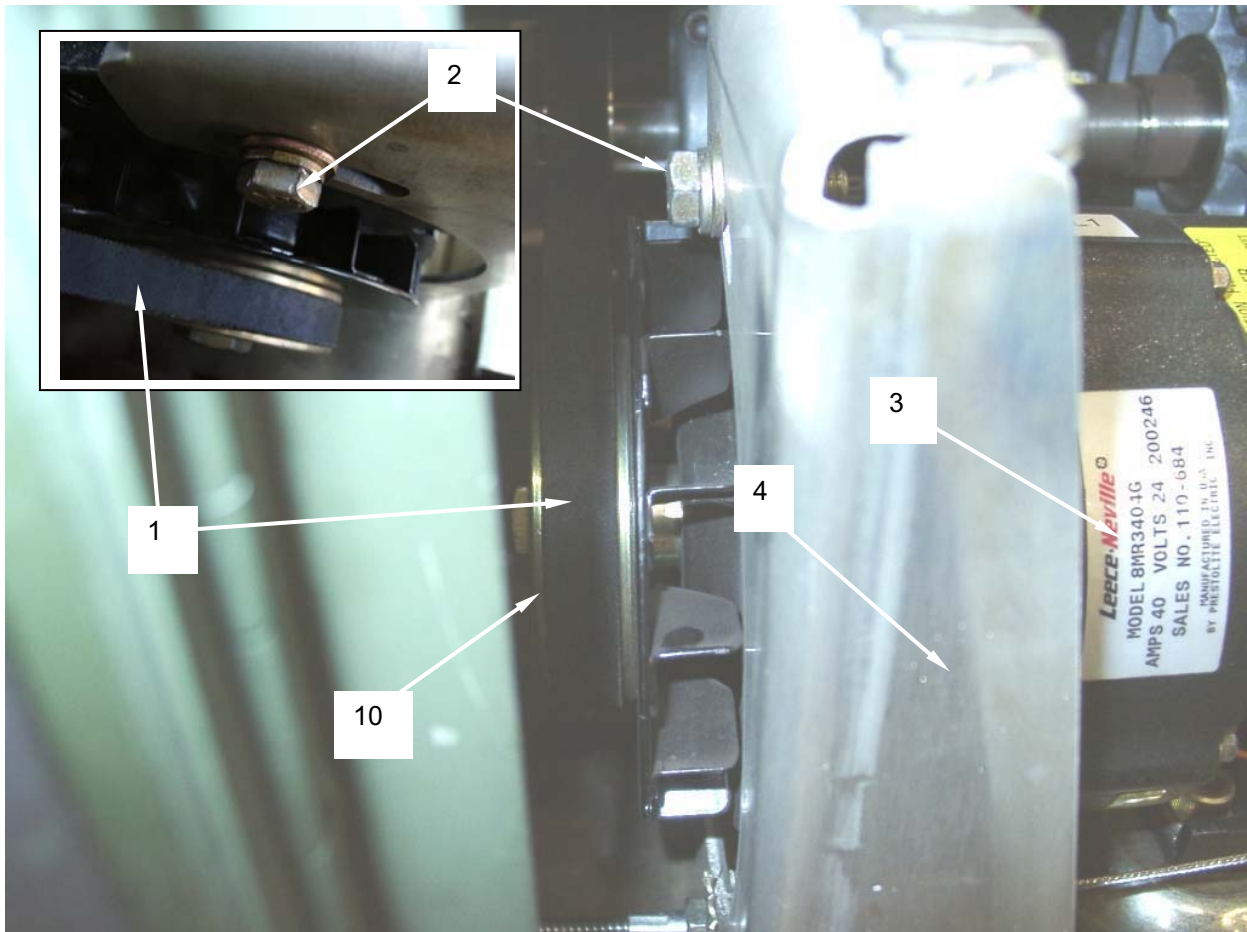

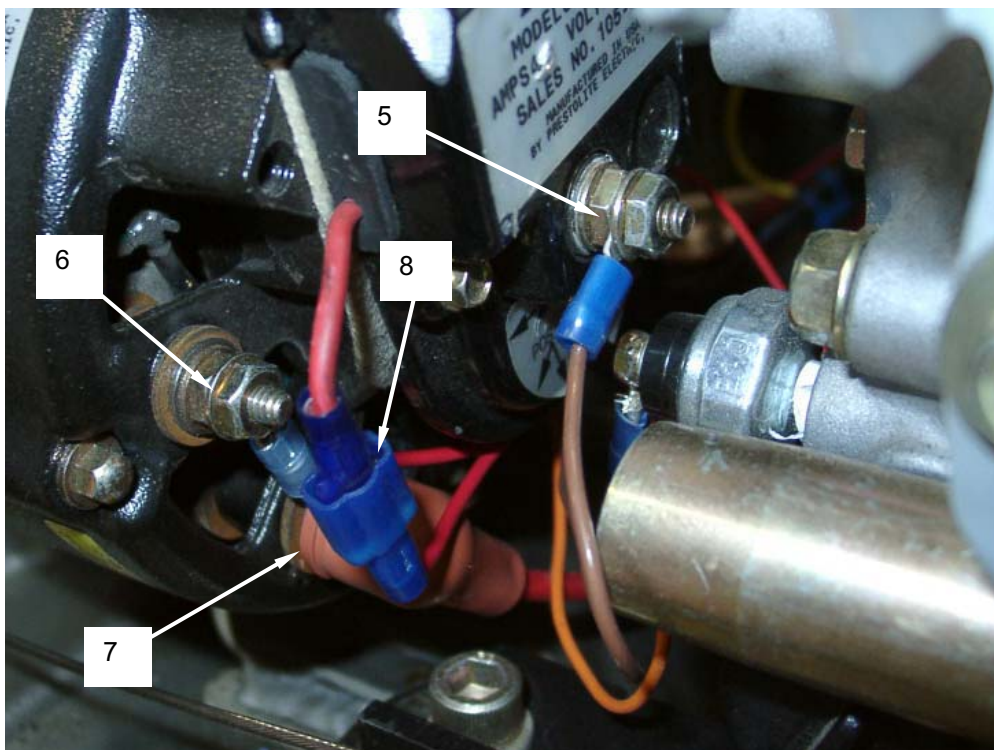
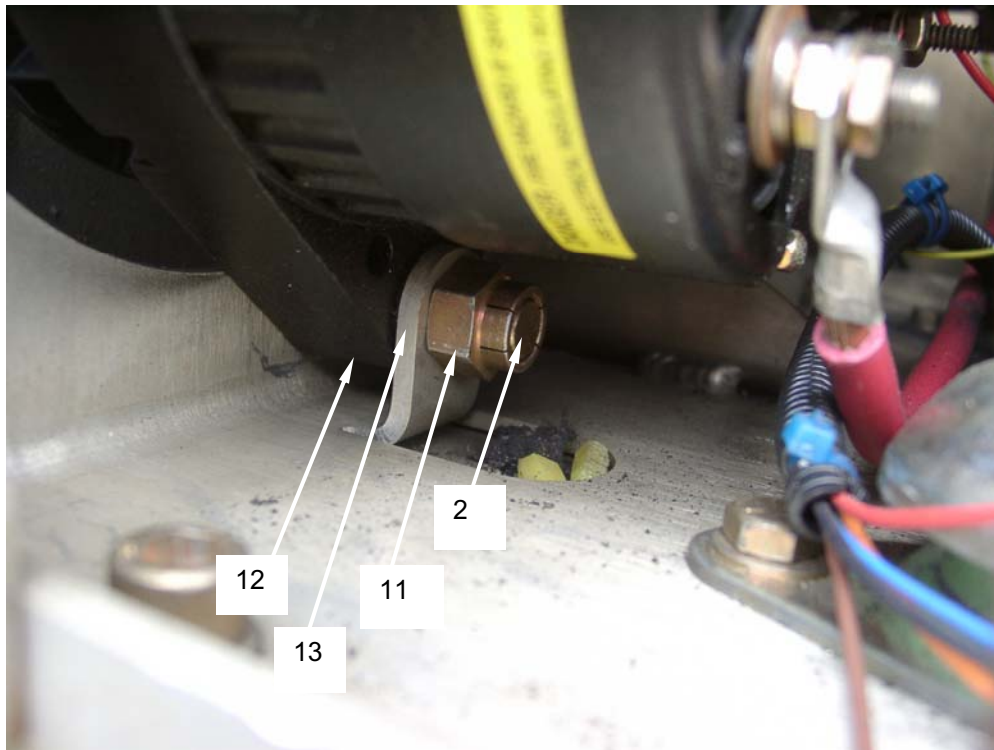

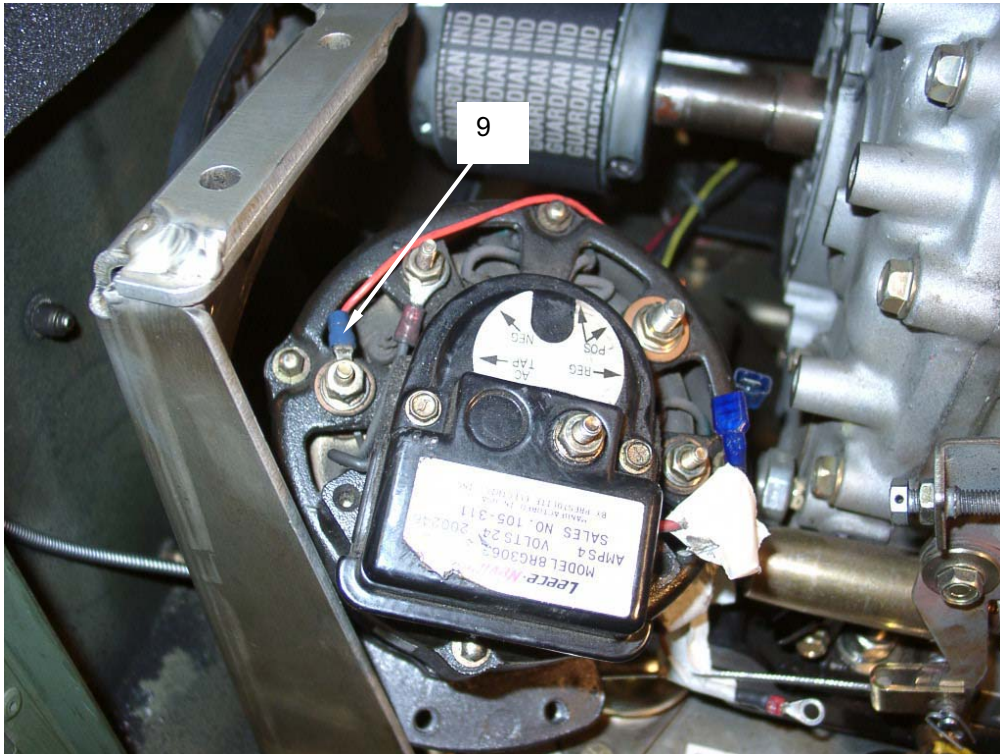

END OF WORK PACKAGE

**FIELD (UNIT) MAINTENANCE
LARGE CAPACITY FIELD HEATER (LCFH)
NSN 4520-01-500-1534
COUPLING ASSEMBLY
REPLACE**

INITIAL SETUP:**Tools**

Tool Kit, General Mechanics (Item 2,
WP 0092 00)
Wrench, Torque (Item 12, WP 0092 00)
Adapter, 3/8-inch drive to 1/4-inch Hex Key
(Item 15, WP 0092 00)

Materials/Parts

Brush, Brass Wire (Item 7, WP 0119 00)

Personnel Required

MOS 63J or 52C

Equipment Condition

Heater shut down and cool (WP 0005 00)
Main Battery Power Switch in the OFF position
and handle removed

REPLACE

1. Open the engine bay access door to gain access to the coupling assembly.

NOTE

Set screws that secure coupling assembly are torqued to 264 to 300 inch-pounds and may require an aid to improve torque and assist in removal.

2. Completely remove the hex cap screw **(1)** of the left hand portion **(2)** of the coupling assembly **(3)** located on the inlet fan shaft **(4)**.
3. Completely remove the hex cap screw **(5)** on the right portion **(6)** of the coupling assembly **(3)** located on the engine drive shaft **(7)**.
4. Insert flat screwdrivers **(10)** into the slot **(11)** on each portion **(2 and 6)** of the coupling assembly to assist in releasing the grip on the fan and engine shafts. Tap screwdriver into slot with a hammer. Take care not to damage the ridge **(12)** on the left and right portions of the coupling assembly.
5. Tap the left hand portion **(2)** and right hand portion **(6)** of the flexible coupling assembly to break the bond between the coupling assembly hubs and their respective shafts.
6. Remove the center rubber section **(8)** of the coupling assembly. Since there is minimum clearance between the ends of the two shafts and it will require rotating the rubber portion down so that the edge fits between the ends of the shafts in order to remove.

NOTE

It may be necessary to push the entire engine assembly to the right slightly in order to gain the necessary clearance between the shafts in order to remove and install the portions of the coupling assembly.

7. Slide the right hand portion **(6)** of the coupling assembly **(3)** left along the engine drive shaft **(7)** and remove.

8. Slide the left hand portion **(2)** of the coupling assembly **(3)** to the right off the fan drive shaft **(4)** and remove.
9. Completely remove the hex cap screws **(1 and 5)** on both the left and right hand portions of the new coupling assembly.
10. Slide one portion **(2)** of the new coupling assembly **(3)** onto the fan drive shaft **(4)** taking care to align the slot **(10)** on the left portion **(2)** of the coupling assembly **(3)** and the woodruff key **(9)** mounted on the fan drive shaft **(4)**.
11. Slide the left portion **(2)** of the coupling assembly **(3)** onto the fan drive shaft **(4)** until the left edge is 1/2 inch from the fan drive pulley **(13)**.
12. Slide the right portion **(6)** of the new coupling assembly **(3)** onto the engine shaft drive **(7)** taking care to align the slot **(10)** on the right portion **(6)** of the coupling assembly and the woodruff key **(9)** mounted on the engine drive shaft **(7)**.
13. Slide the right portion **(6)** of the coupling assembly onto the engine shaft **(7)** allowing sufficient room to insert the center rubber section **(8)**.
14. Install the center rubber section **(8)** of the coupling assembly between the left **(2)** and right **(6)** portions of the coupling assembly **(3)**.
15. Slide the right portion **(6)** of the coupling assembly left along the engine drive shaft **(7)** until the gap between the right edge of the rubber section and the ridge **(12)** of the right portion **(6)** is 1/8 inch. The gap is provided to allow for the expansion of the coupling due to heating.
16. Ensure that the "teeth" **(11)** on the center rubber section **(8)** mate properly with the "teeth" **(12)** on the left and right portion of the coupling assembly.
17. Using a torque wrench equipped with a 3/8-inch drive to 1/4-inch hex key adapter, install and torque the hex head cap screws **(1 and 5)** on the left **(2)** and right **(6)** portions of the coupling assembly to 264 to 300 inch-pounds.
18. Close the engine access door.
19. Operate the heater for one hour. Check for "walk" left or right of the coupling assembly. Check the torque on the hex head cap screws **(1 and 5)** and verify that it is still 261 to 300 inch-pounds. Re-torque as required.

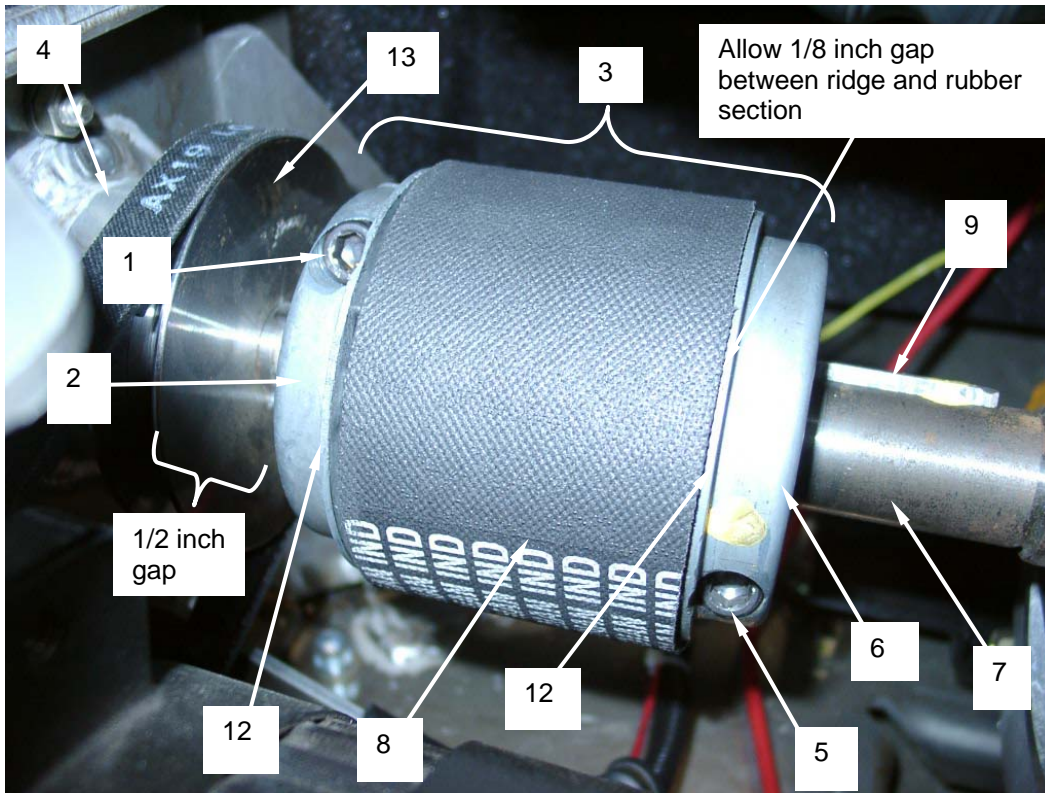

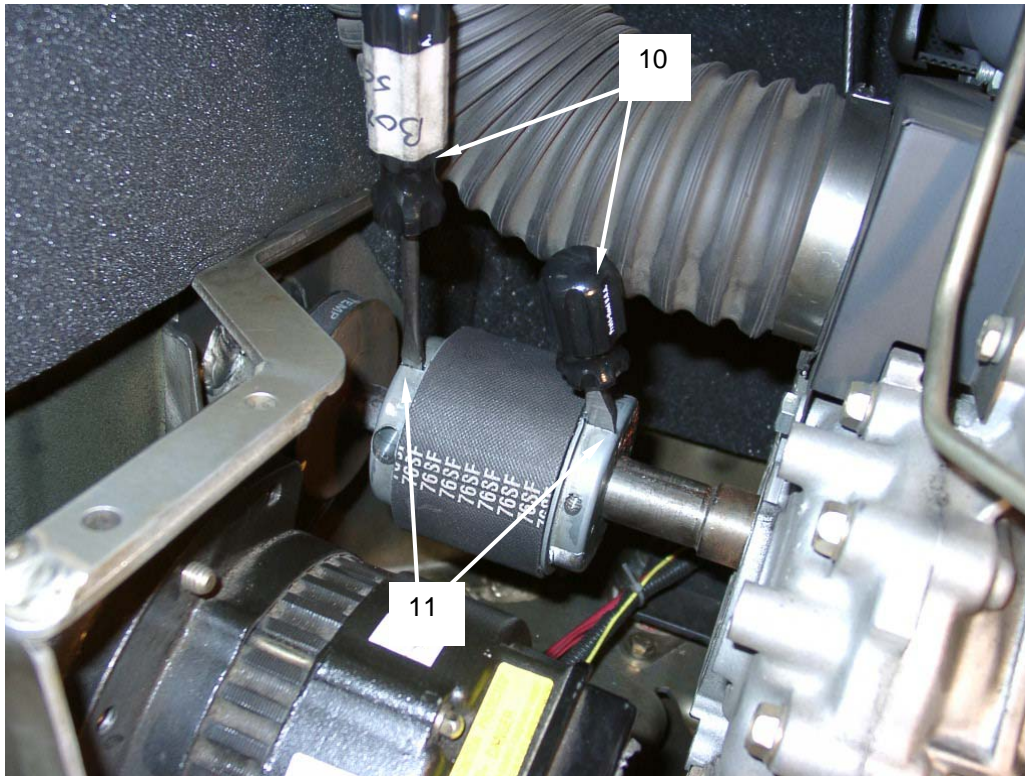

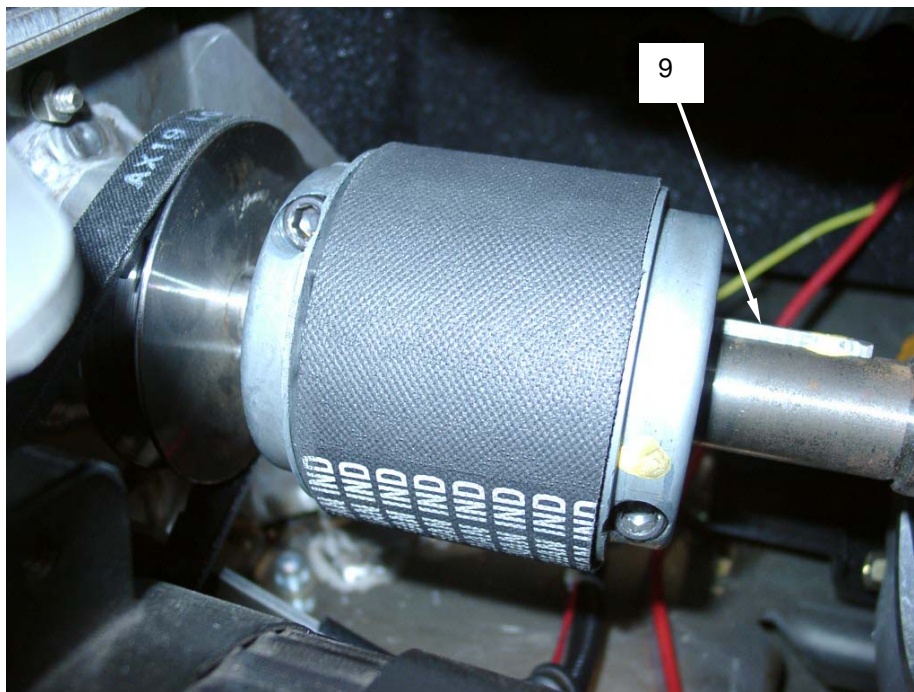
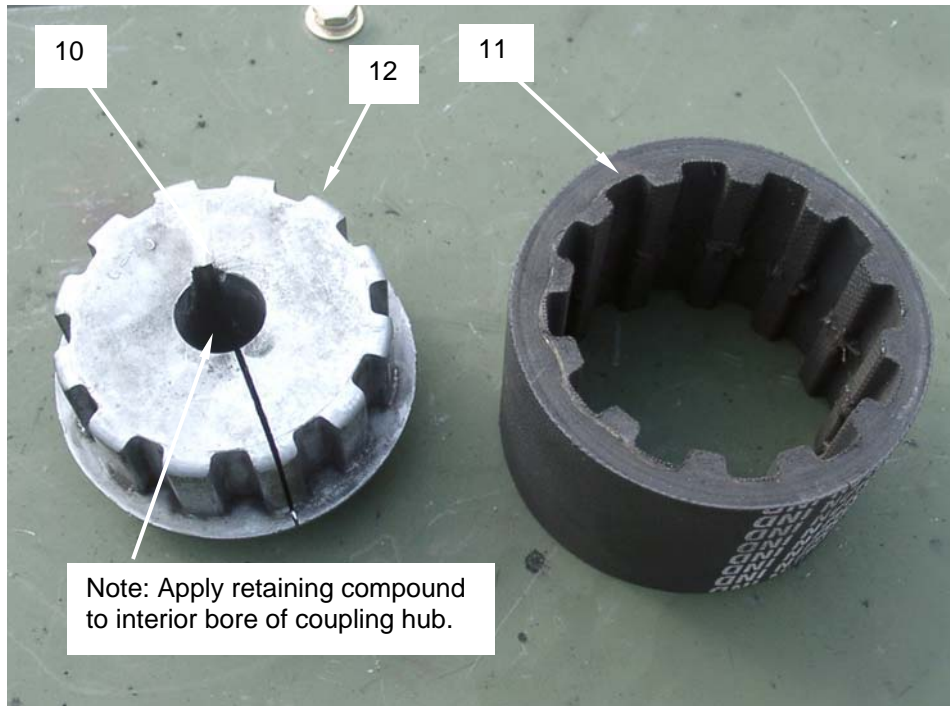

END OF WORK PACKAGE

FIELD (UNIT) MAINTENANCE

LARGE CAPACITY FIELD HEATER (LCFH)

NSN 4520-01-500-1534

ROCKER ARM ASSEMBLY
REMOVE, ADJUST, INSTALL**INITIAL SETUP:****Tools**Tool Kit, General Mechanic's Automotive (Item 2,
WP 0092 00)**Personnel Required**

MOS 63J or 52C

Materials/Parts

None required

Equipment ConditionHeater shut down and engine cool
Main battery switch to OFF and handle removed**NOTE**

Engine maintenance requires metric tools for the removal of all hardware and assemblies.

HEAD COVER REMOVAL

Remove head cover **(1)** from cylinder head **(2)** by removing bolts **(3)**. Remove cover gasket **(4)** only if replacement is required.

VALVE CLEARANCE ADJUSTMENT

1. Remove flywheel housing IAW WP 0045 00.
2. Rotate flywheel in the clockwise direction until T mark **(5)** on flywheel matches V mark **(6)** on cylinder body fin. This is the top dead center (TDC) position. Intake and exhaust valves will be in closed position.
3. Using a gap setting gauge **(7)**, check rocker arm **(8)** to valve **(9)** clearance. Clearance shall be 0.004 to 0.008 inch (0.10 to 0.20 mm). The amount of drag on the gap setting gauge when passing through the gap shall be minimal.
4. If adjustment is required, loosen lock nut **(10)** and rotate adjusting screw **(11)** clockwise/counter-clockwise to expand/reduce gap. Tighten lock nut **(10)** and recheck clearance.
5. Repeat steps 3 and 4 until proper clearance is attained.
6. Install head cover **(1)** onto cylinder head **(2)** using bolts **(3)**.
7. Install flywheel cover IAW WP 0045 00.

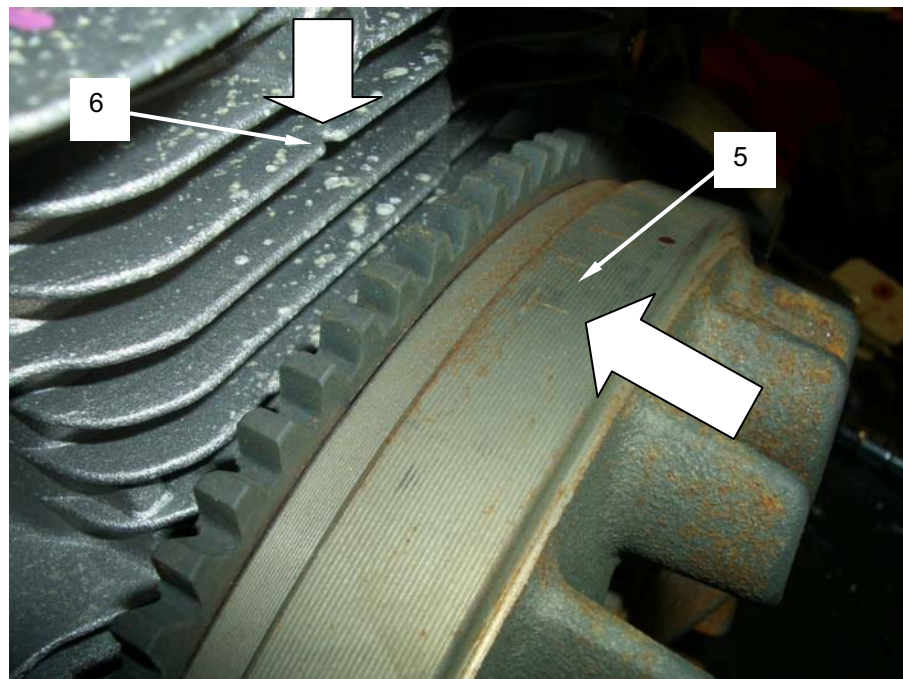
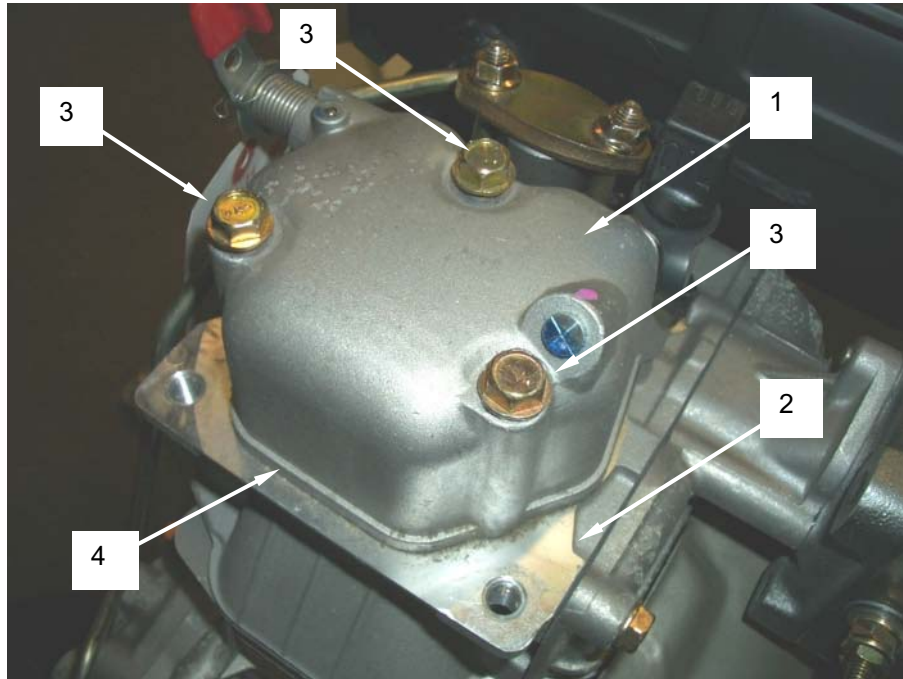

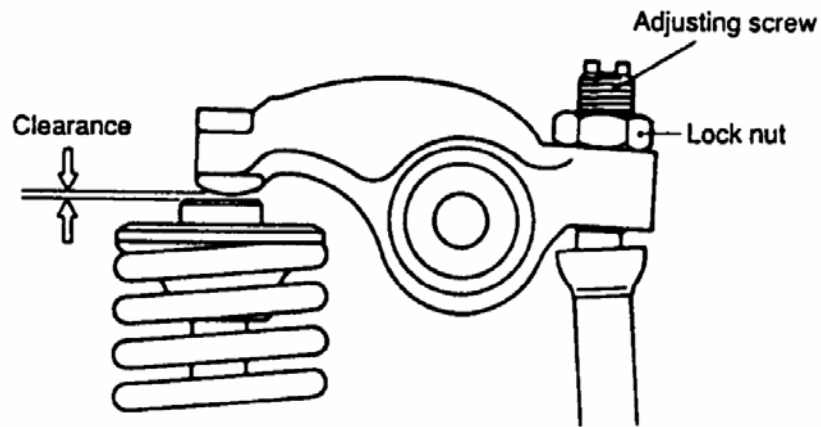
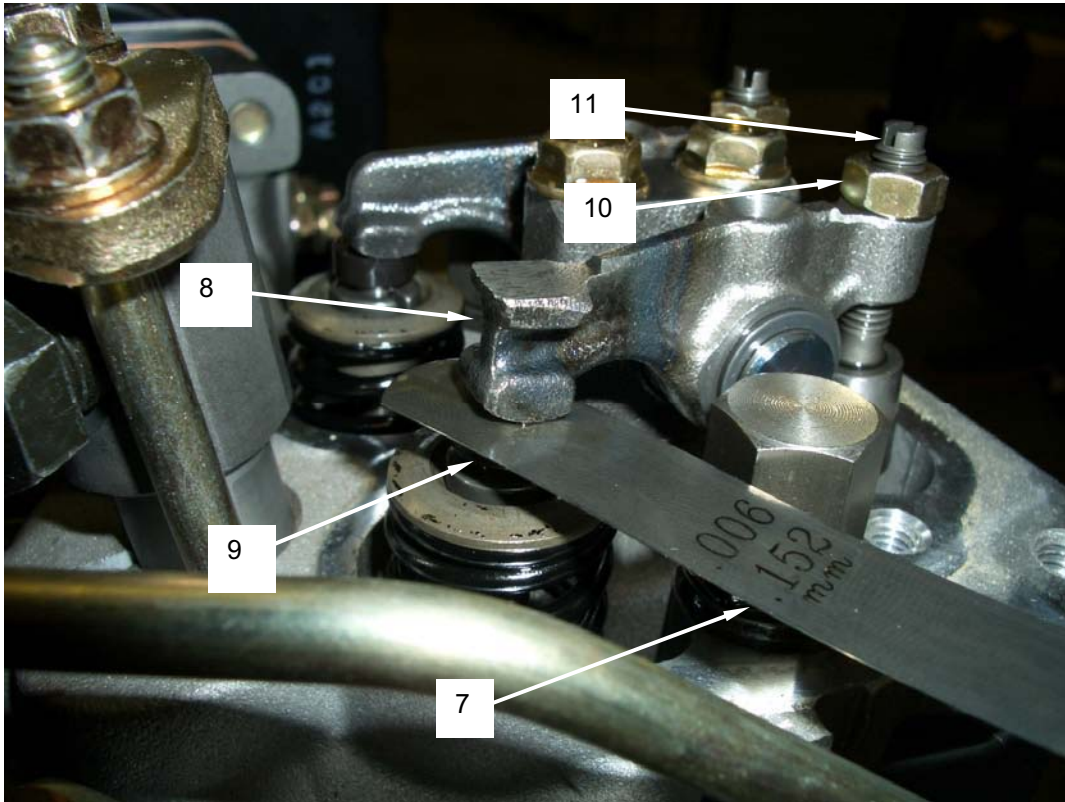

END OF WORK PACKAGE

FIELD (UNIT) MAINTENANCE

LARGE CAPACITY FIELD HEATER (LCFH)

NSN 4520-01-500-1534

AIR CLEANER ASSEMBLY
REMOVE, SERVICE, INSPECT, INSTALL

INITIAL SETUP:

ToolsTool Kit, General Mechanic's Automotive (Item 2,
WP 0092 00)**Personnel Required**

MOS 63J or 52C

Materials/PartsSolvent, degreasing (Item 24, WP 0119 00)
Rags, wiping (Item 4, WP 0119 00)**Equipment Condition**Heater shut down and engine cool
Main battery switch OFF and handle removed

NOTE

Engine maintenance requires metric tools for the removal of all hardware and assemblies.

REMOVE

1. Remove cover (1) from air filter housing (2) by removing wing nut (3) and washer (4).
2. Remove air filter element (5) from housing (2). Remove housing from adapter (6) by removing three screws (7).
3. If replacement of air heaters (8) is required, disconnect electrical wire leads from heaters by removing two nuts (9) and washers (10). Reinstall nuts and washers to prevent loss.
4. Remove adapter (6), air heaters (8), and gaskets (11) from adapter (12) by removing four screws (13) and washers (14).
5. Remove adapter (12) from air intake duct (15) by removing three nuts (16). Remove gasket (17). Remove studs (18) from duct only if replacement is required.
6. Remove air intake duct (15) from cylinder head by removing two screws (19). Remove gasket (20).

SERVICE

**WARNING**

Cleaning solvents are flammable and toxic to eye, skin, and respiratory tract. Skin and eye protections are required when working in contact with cleaning solvents. Avoid repeated or prolonged contact. Work in well ventilated area only. Keep away from heat, sparks, and open flame. Do not smoke while using cleaning solvent. Failure to observe this warning can result in injury or death to personnel.

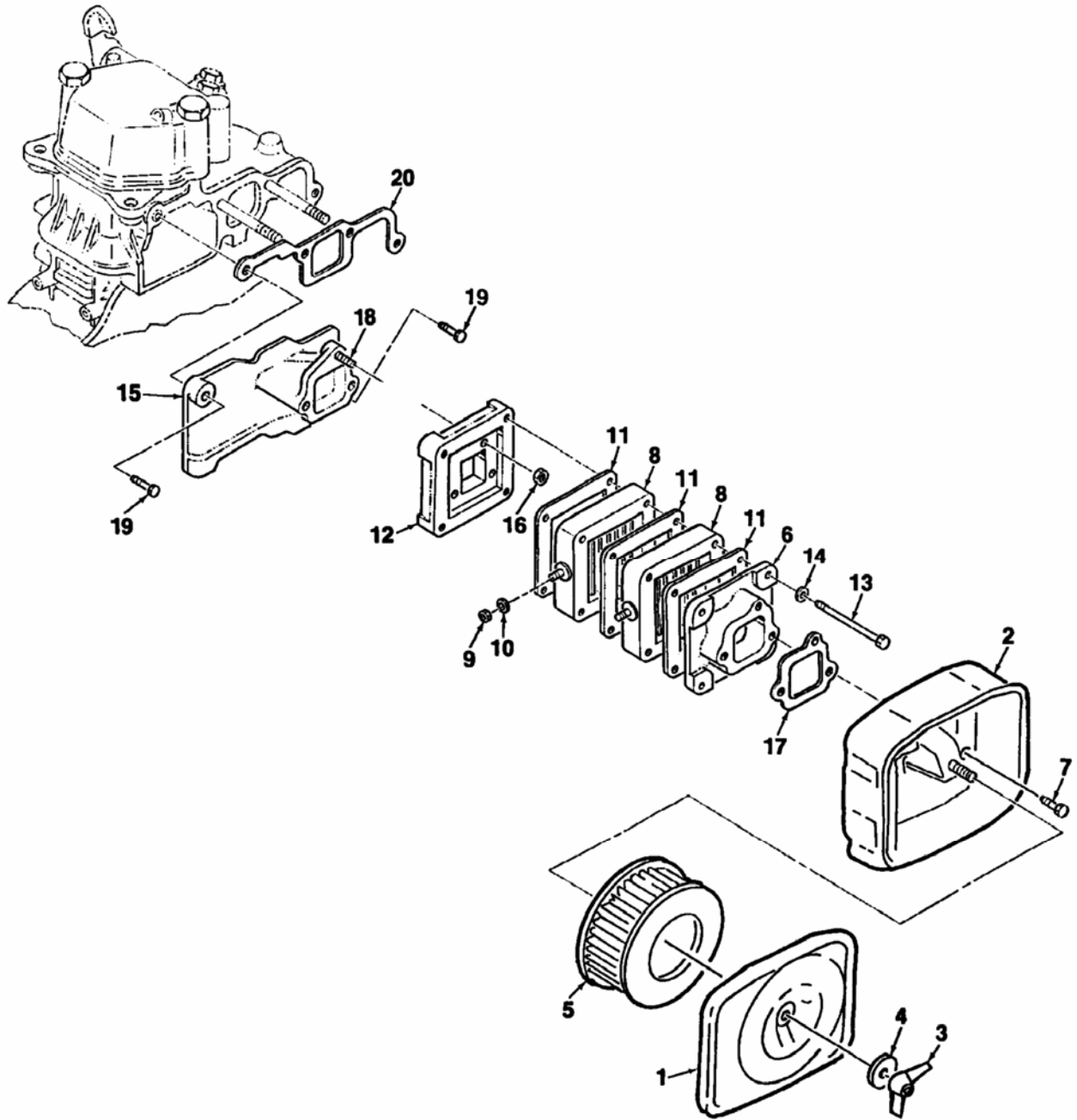

Do not clean air filter element. Do not tap or hit to remove dirt. If element is clogged or dirty, replace it.

1. Clean electrical connection studs on air heaters with a stiff wire brush.
2. Clean remaining components with cleaning solvent and a clean rag. Allow to air dry.

INSPECT

1. Inspect cover **(1)**, housing **(2)**, adapters **(6, 12)**, and air intake duct **(15)** for cracks, dents, or corrosion. Replace component if damaged to the extent that it will effect proper operation of the air filtering system.
2. Inspect air heaters **(8)** for obvious damage. Replace if damaged is suspected.
3. Inspect gaskets **(11, 17, 20)** for cuts, tears, or deformation. Replace if damaged or deformed.

INSTALL

1. If removed, install air intake duct **(15)** and gasket **(20)** using two screws **(19)**. Install studs **(18)**.
2. Install adapter **(12)** and gasket **(17)** using three nuts **(16)**.
3. Install adapter **(6)**, air heaters **(8)** and gaskets **(11)** using four screws **(13)** and washers **(14)**. Connect electrical wire leads to heaters using nuts **(9)** and washers **(10)**.
4. Install filter housing **(2)** using three screws **(7)**. Install filter element **(5)** into housing.
5. Install cover **(1)** onto housing **(2)** and secure using wing nut **(3)** and washer **(4)**.

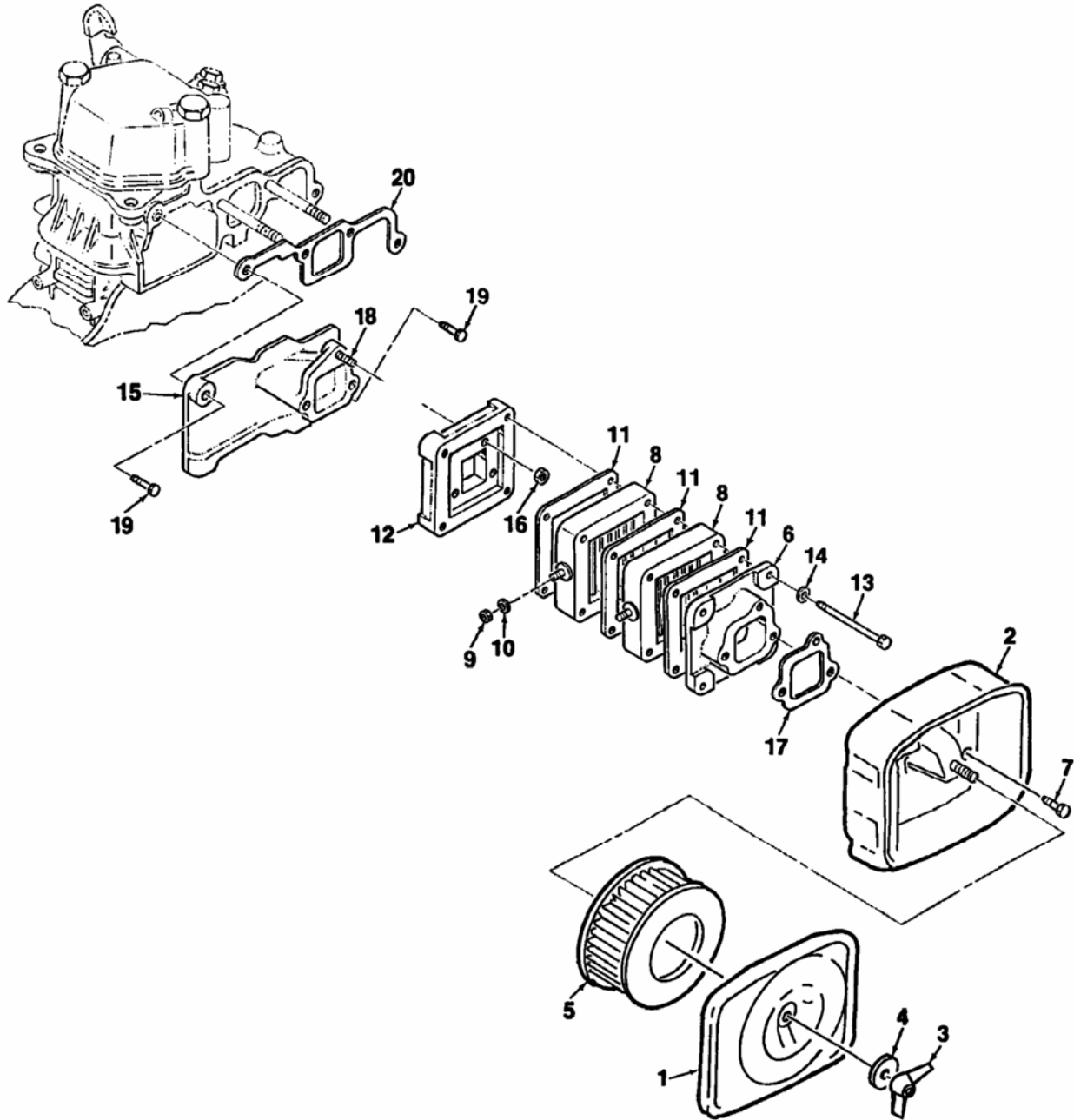

END OF WORK PACKAGE

**FIELD (UNIT) MAINTENANCE
LARGE CAPACITY FIELD HEATER (LCFH)
NSN 4520-01-500-1534
DIESEL ENGINE FUEL INJECTOR
REMOVE, INSPECT, INSTALL**

INITIAL SETUP:**Tools**

Tool Kit, General Mechanic's Automotive
(Item 2, WP 0092 00)
Wrench, Torque (Item 19, WP 0092 00)

Personnel Required

MOS 63J or 52C

Materials/Parts

Bolt, M8 or M9 x 100mm, minimum length (Item
29, WP 0119 00)

Equipment Condition

Heater shut down and engine cool
Main battery switch OFF and handle removed

NOTE

Engine maintenance requires metric tools for the removal of all hardware and assemblies.

REMOVE

1. Disconnect rigid fuel supply line **(1)** from fuel injector **(2)**. Disconnect fuel return hose **(3)** by loosening clamp **(4)**.
2. Remove opposite end of rigid fuel line **(5)** on fuel injector pump **(6)**.
3. Remove two nuts **(7)** and nozzle retainer **(8)** from studs **(9)**.

CAUTION

When removing fuel injector, wrap it in a clean cloth to protect injector nozzle. Do not place nozzle tip directly onto a hard surface, as damage will result.

4. Carefully remove fuel injector **(2)** from injection port **(10)** in cylinder head.
5. Remove injector spacer **(11)** and gasket **(12)** from injector port **(10)**. Discard gasket.

INSPECT

1. Inspect fuel injector **(2)** for obvious damage. Check for clogged or dirty injector nozzle. Replace injector if nozzle is damaged.
2. Inspect return rigid fuel line **(1)** for cuts, kinks, or crimping. Replace rigid fuel line if damaged.
3. Inspect return fuel hose **(3)** for cuts, tears, kinks, or crimping. Replace fuel hose if damaged.

INSTALL

1. Install new gasket (12) into cylinder head injector port (10). Ensure proper seating. Install fuel spacer (11).

CAUTION

When installing fuel injector, use care to prevent damage to injector nozzle.

2. Carefully position and insert fuel injector (2) into cylinder head. Ensure fuel pipe fitting (13) is facing the correct direction.
3. Install nozzle retainer (8) onto studs (9). Install nuts (7) and torque to 87 to 104 inch-pounds (100 to 120 kg-cm).
4. Connect fuel return hose (3) to fuel injector (2) and tighten clamp (4).
5. Connect rigid fuel supply line (1) to fuel injector (2).
6. Connect opposite end of rigid fuel line (5) to fuel injector pump (6).

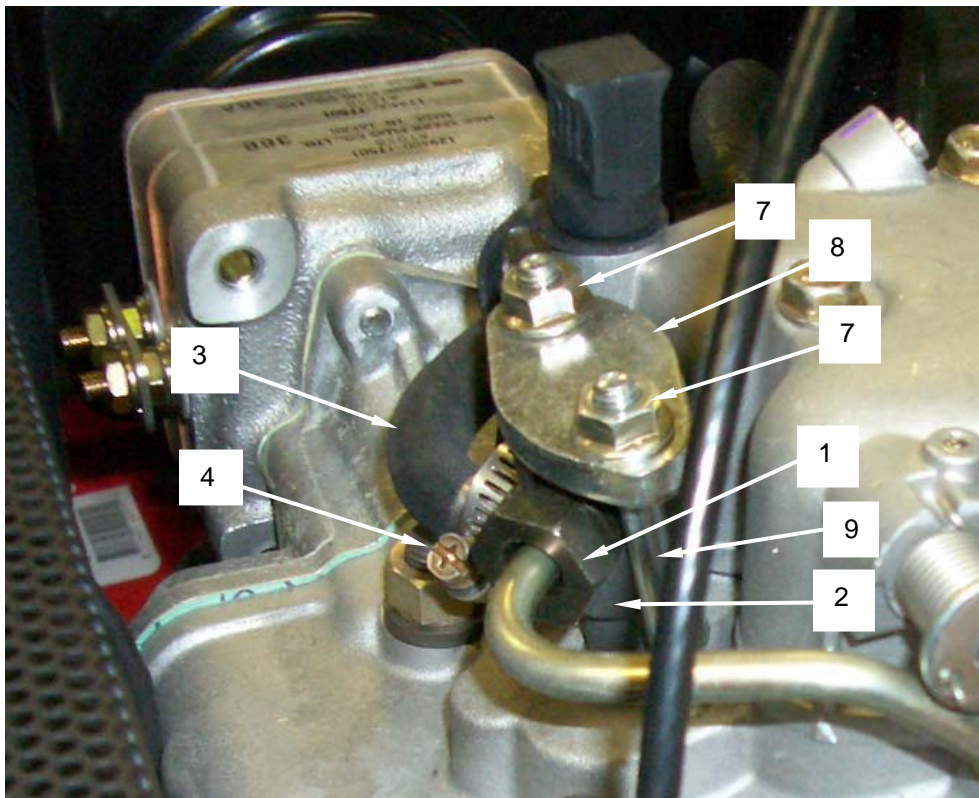

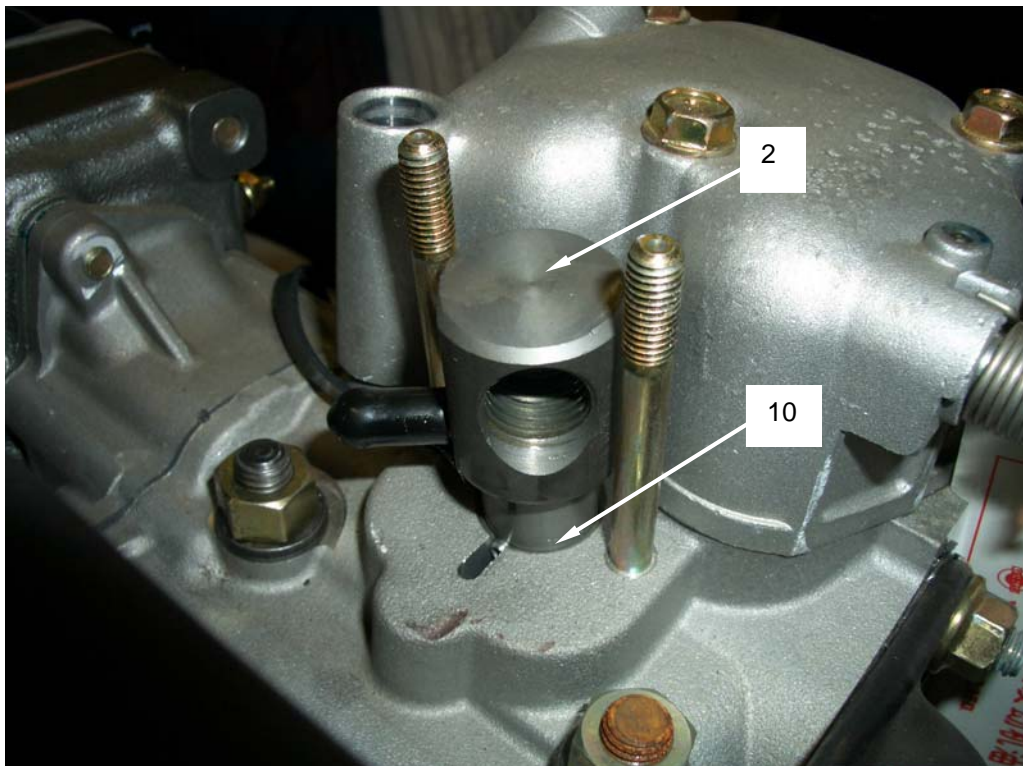
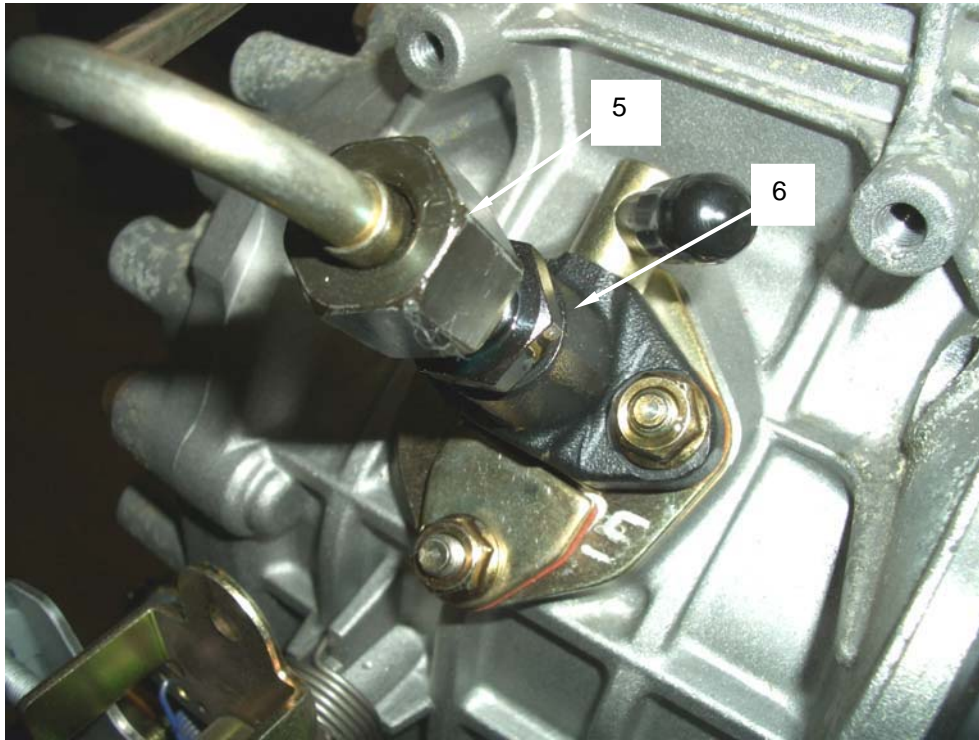

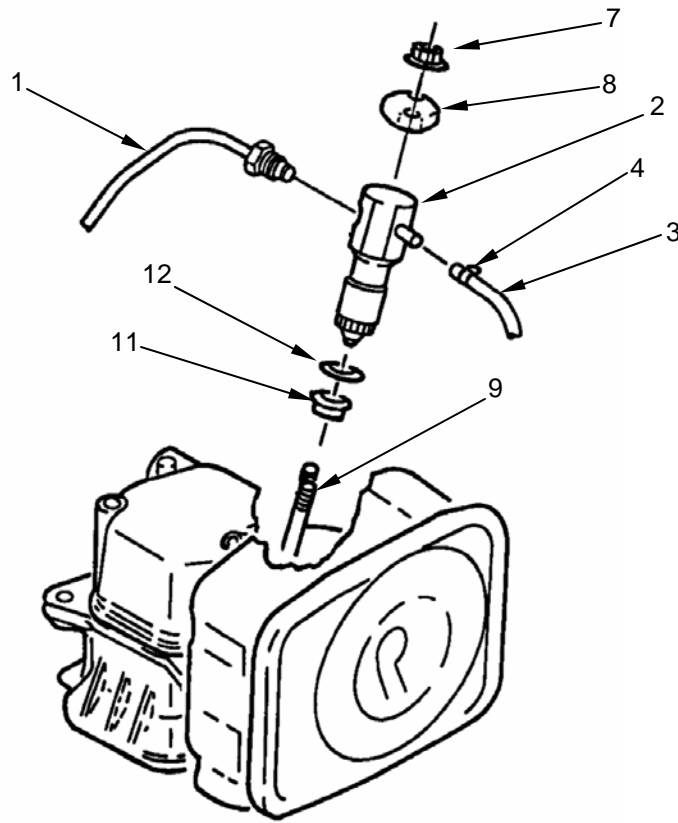

END OF WORK PACKAGE

FIELD (UNIT) MAINTENANCE**LARGE CAPACITY FIELD HEATER (LCFH)****NSN 4520-01-500-1534****STARTER MOTOR****REMOVE, SERVICE, INSPECT, INSTALL**

INITIAL SETUP:**Tools**

Tool Kit, General Mechanics (Item 2, WP 0092 00)

Personnel Required

MOS 63J or 52C

Materials/PartsSolvent, degreasing (Item 24, WP 0119 00)
Rag, wiping, clean (Item 4, WP 0119 00)**Equipment Condition**Heater shut down and cool.
Engine bay access door open.
Remove negative battery cable closest to engine bay access door opening.
Remove engine cabinet cover over engine bay
Main battery switch OFF and handle removed.

NOTE

Engine maintenance requires metric tools for the removal of all hardware and assemblies.

REMOVE

1. Remove engine muffler **(1)** by removing the two nuts **(2)** on the left side engine exhaust studs **(3)**.
2. Remove two bolts **(4)** retaining the lower rear muffler bracket to the engine.
3. Once muffler has been removed, place the muffler **(1)** out of the way on top of the heater cabinet. Remove gasket **(5)** and set aside.
4. Tag and disconnect electrical wires **(6, 7)** from connection stud **(8)** by removing nut **(9)** and washer **(10)**. Reinstall nut **(9)** and washer **(10)** to prevent loss.
5. Tag and disconnect electrical wire **(11)** from starter solenoid lug.
6. Remove starter motor **(12)** from cylinder block by removing the lower bolt **(13)** followed by the upper bolt **(14)**.

SERVICE**WARNING**

Cleaning solvents are flammable and toxic to eye, skin, and respiratory tract. Skin and eye protections are required when working in contact with cleaning solvents. Avoid repeated or prolonged contact. Work in well ventilated area only. Keep away from heat, sparks, and open flame. Do not smoke while using cleaning solvent. Failure to observe this warning can result in injury or death to personnel.

Clean starter motor with cleaning solvent and a clean rag. Allow to air dry.

INSPECT

1. Inspect starter motor body for deformation, dents, cracks, deformation, or obvious damage. Replace starter motor if damaged.
2. Inspect solenoid for evidence of electrical short. Inspect electrical connection studs for corrosive damage. Replace starter motor if any damage is suspected.

INSTALL

1. Install starter motor **(12)** into cylinder block. Install upper bolt **(14)** followed by lower bolt **(13)**.
2. Connect electrical wire **(11)** to start solenoid lug.
3. Connect electrical wires **(6,7)** to connection stud **(8)** using nut **(9)** and washer **(10)**. Hand tighten nut until resistance is met. Tighten nut one additional quarter turn with open end wrench.
4. Install muffler gasket **(5)** in position on engine muffler studs **(3)**.
5. Position muffler **(1)** on engine and install on engine muffler studs **(3)**.
6. Install two bolts **(4)** retaining the lower rear muffler bracket to the engine.
7. Install two nuts **(2)** on engine muffler studs **(3)**. Tighten securely.

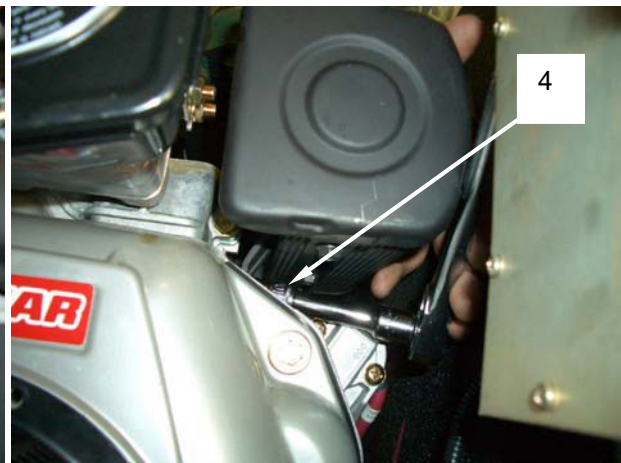
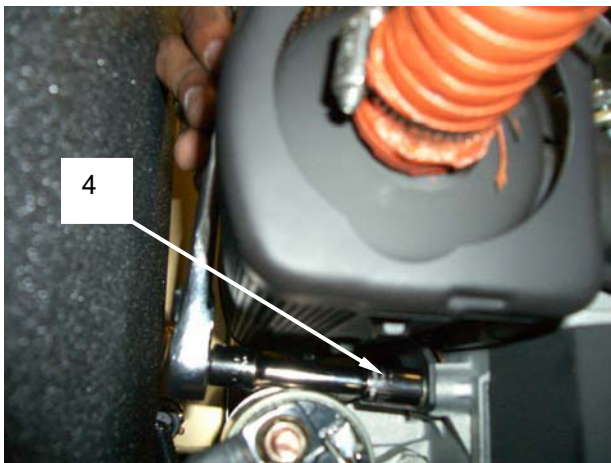
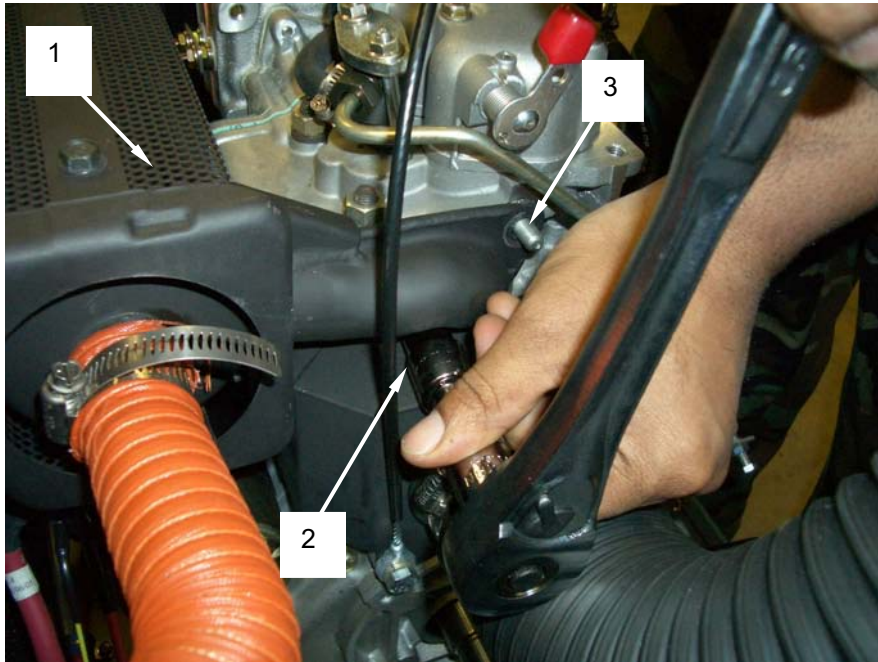

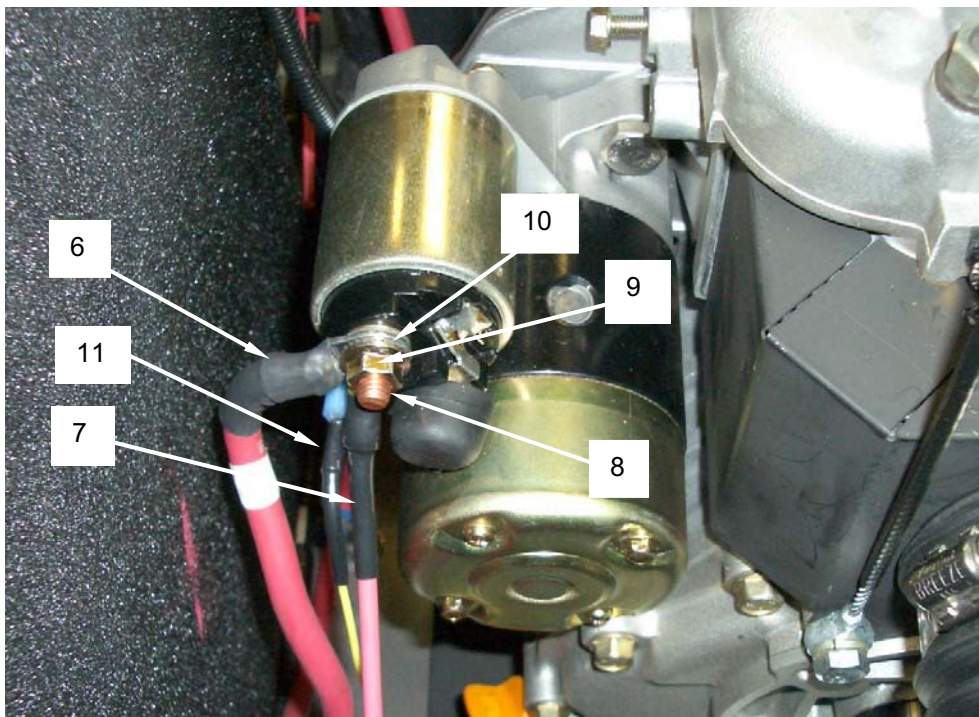
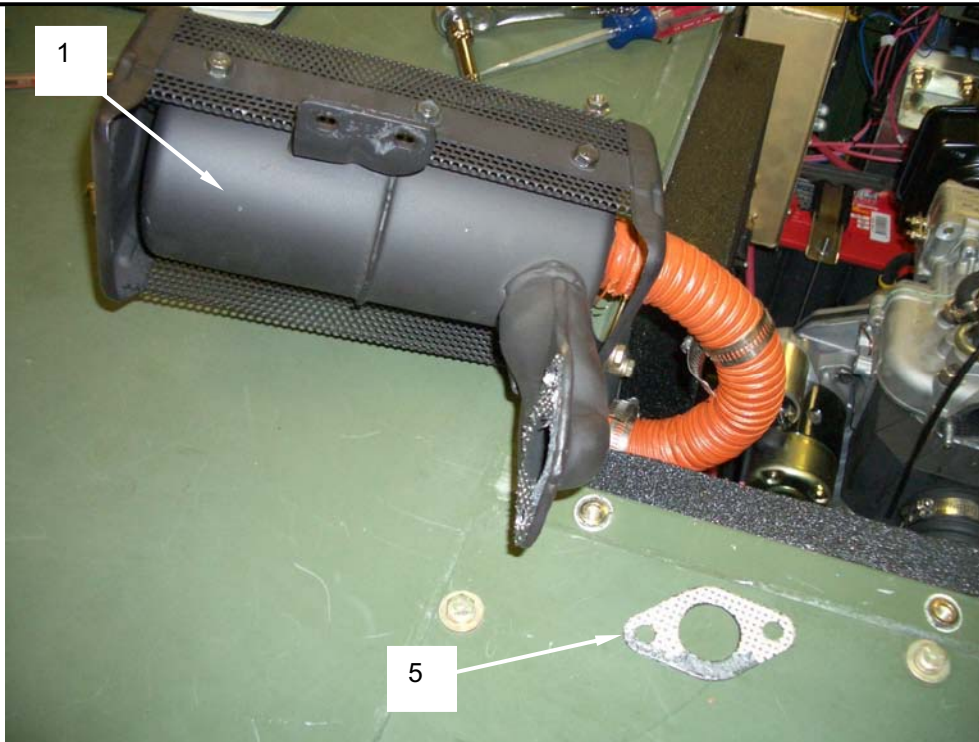

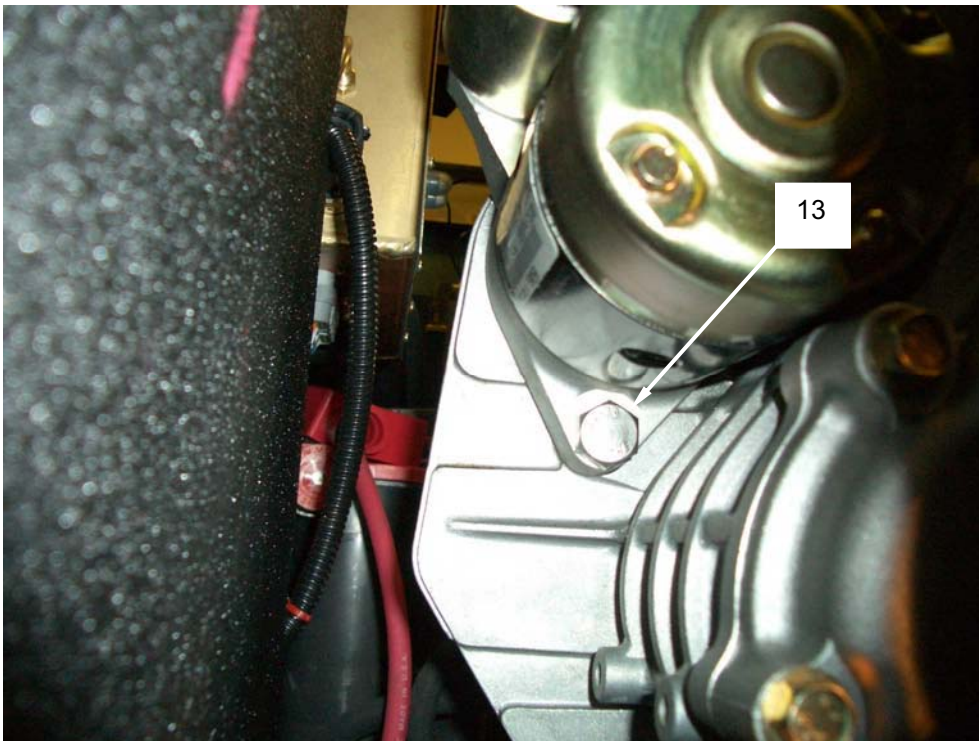
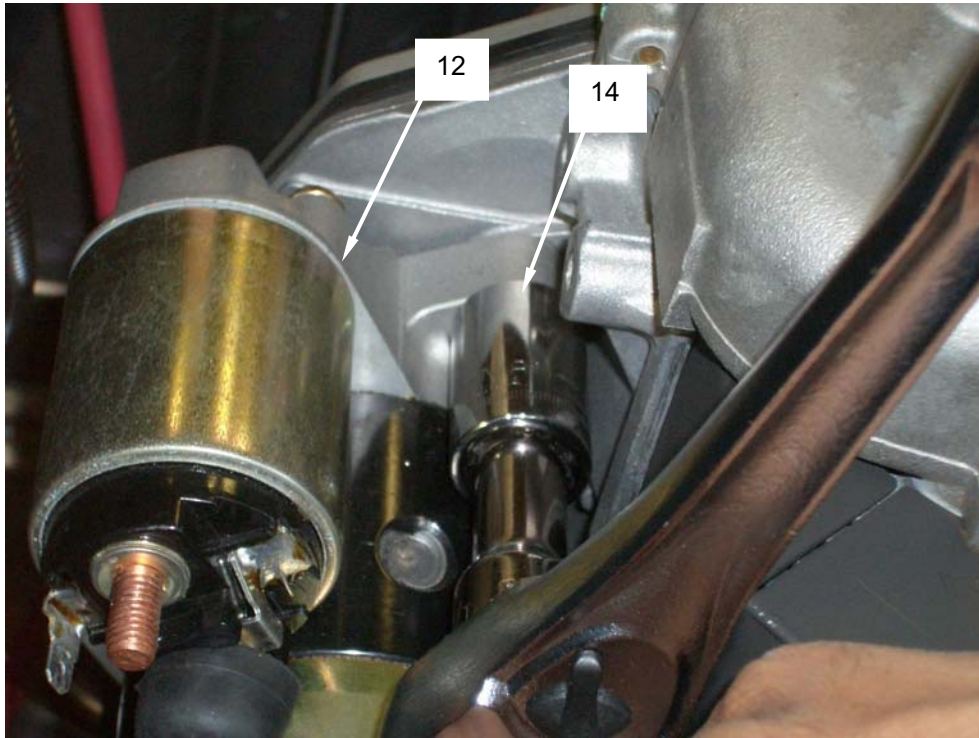

END OF WORK PACKAGE

0044 00-5/(6 Blank)

FIELD (UNIT) MAINTENANCE

LARGE CAPACITY FIELD HEATER (LCFH)

NSN 4520-01-500-1534

FLYWHEEL HOUSING AND COVER
REMOVE, SERVICE, INSPECT, INSTALL

INITIAL SETUP:

Tools

Tool Kit, General Mechanics (Item 2, WP 0092 00)

Personnel Required

MOS 63J or 52C

Materials/Parts

Solvent, dry cleaning (Item 24, WP 0119 00)
Rag, wiping, clean (Item 4, WP 0119 00)

Equipment Condition

Heater shut down and cool.
Engine bay access door open.
Main battery switch OFF and handle removed
Remove burner fuel pump from flywheel housing and cover (WP 0033 00)

NOTE

Engine maintenance requires metric tools for the removal of all hardware and assemblies.

REMOVE

1. Remove flywheel housing (1) from cylinder block (2) by removing four bolts (3) and washers (4).
2. Remove the cylinder head fin cover (5) by removing bolt (6), grommet (7), and collar (8). Remove seal (9).

SERVICE

**WARNING**

Cleaning solvents are flammable and toxic to eye, skin, and respiratory tract. Skin and eye protections are required when working in contact with cleaning solvents. Avoid repeated or prolonged contact. Work in well ventilated area only. Keep away from heat, sparks, and open flame. Do not smoke while using cleaning solvent. Failure to observe this warning can result in injury or death to personnel.

Clean components with cleaning solvent and a clean rag. Allow to air dry.

INSPECT

1. Inspect flywheel housing (1) and cylinder fin cover (5) for cracks, deformation, or obvious damage. Replace if damaged.
2. Inspect seals (9) for cracks, cuts, damage, or deterioration. Replace if damaged in any way.

INSTALL

1. Install seal (9) onto cylinder head fin cover (5). Install cover using screw (6), grommet (7), and collar (8).
2. Mate flywheel housing (1) to cylinder block (2). Secure using four screws (3) and washers (4).



END OF WORK PACKAGE

**FIELD (UNIT) MAINTENANCE
LARGE CAPACITY FIELD HEATER (LCFH)
NSN 4520-01-500-1534
DIESEL ENGINE
SERVICE**

INITIAL SETUP:**Tools**

Tool Kit, General Mechanics (Item 2, WP 0092 00)

Personnel Required

MOS 63J or 52C

Materials/Parts

Lubricating Oil, Engine, (Item 25, WP 0119 00)

Equipment Condition

LCFH power off and allowed to cool for 30 minutes

Main battery switch OFF and handle removed

NOTE

Engine maintenance requires metric tools for the removal of all hardware and assemblies.

SERVICE – CHANGE OIL**WARNING**

Allow the engine to cool for approximately 30 minutes before changing oil. Engine oil is hot and presents a burn hazard. Coming in contact with hot engine oil may cause burns and severe injury.

NOTE

The engine must be standing level and be switched off. Be sure to change the oil when the engine is warm (not hot) so that the engine oil remains easy to drain. Be sure to collect the used oil and dispose of in accordance with Unit SOP and local regulations.

1. Remove engine oil drain hose **(1)** from clamp **(2)**.
2. Direct oil drain hose **(1)** into an approved container and remove oil drain plug **(3)** and allow the oil to drain out.
3. Clean the oil drain plug **(3)** and install on oil drain hose **(1)**.
4. Return engine oil drain hose **(1)** to clamp **(2)**.

CAUTION

The type and viscosity of engine oil used for daily operations is determined by the current local ambient operating temperature/climate range where the LCFH is being used. Use only the engine oils that meet the quality and temperature specifications listed in WP 0002, Table 1. Using an oil other than that listed may result in difficult starting and/or damage to the diesel engine.

5. Add 1.2 US quarts (1.1 liters) of the appropriate specification engine oil (WP 0002 00, Table 1) via the oil level dipstick opening **(4)**. Check oil level by inserting, but not screwing in, the dipstick into the dipstick opening. Fill to the upper mark **(5)** on the dipstick.

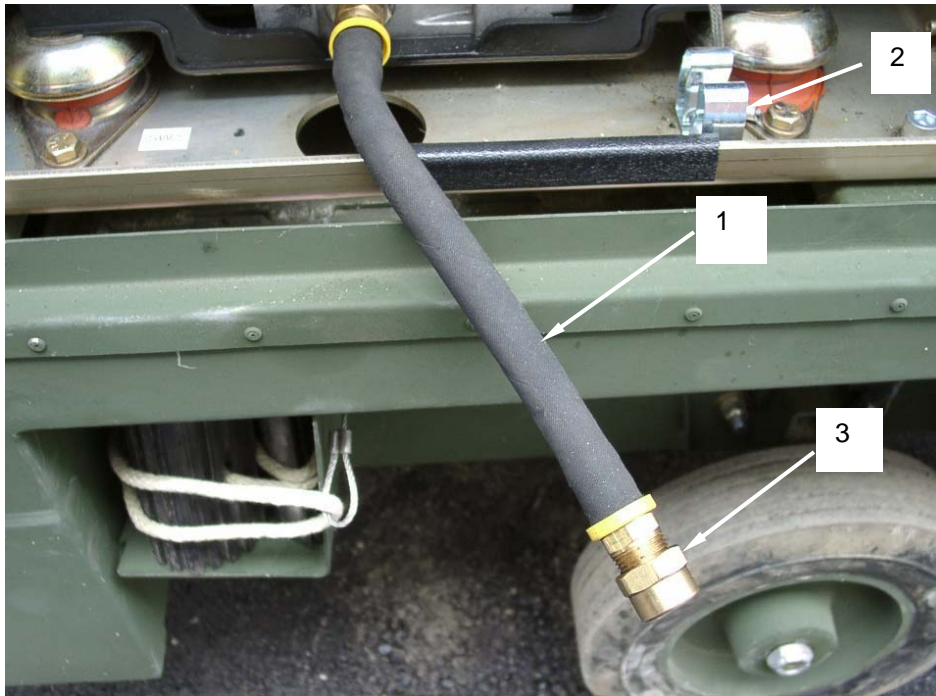

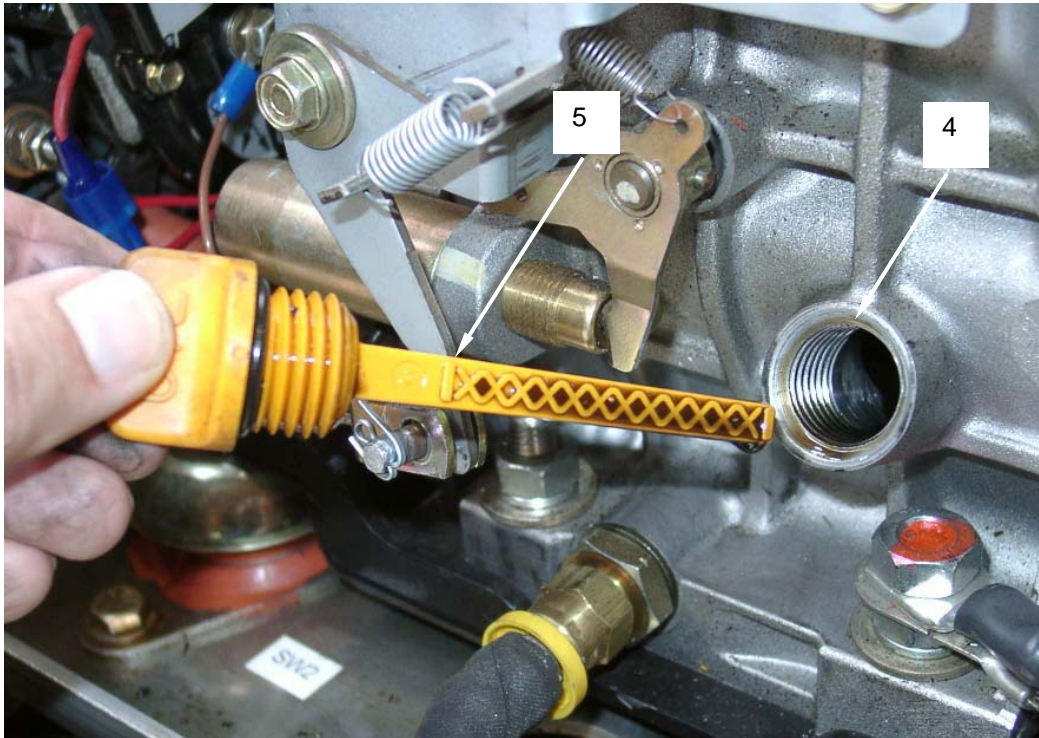

END OF WORK PACKAGE

 FIELD (UNIT) MAINTENANCE

LARGE CAPACITY FIELD HEATER (LCFH)

NSN 4520-01-500-1534

 OIL FILL CAP
 REMOVE, INSPECT, INSTALL

INITIAL SETUP:**Tools**

Tool Kit, General Mechanics (Item 2, WP 0092 00)

Personnel Required

MOS 63J or 52C

Materials/Parts

Oil, engine lubricating (Item 25, WP 0119 00)
 Rag, wiping, clean (Item 4, WP 0119 00)

Equipment Condition

Heater shut down and cool.
 Engine bay access door open.
 Main battery switch OFF and handle removed

NOTE

Engine maintenance requires metric tools for the removal of all hardware and assemblies.

REMOVE

Remove engine oil fill cap **(1)** from engine block **(2)**. Remove O-ring **(3)**.

INSPECT

1. Inspect oil fill cap **(1)** for obvious damage.
2. Inspect O-ring **(3)** for cuts, tears, or permanent set. Replace O-ring if it will not allow a proper seal.
3. Inspect area around oil fill port for evidence of leakage. Clean area of dirt and accumulated grime using a clean rag.

INSTALL

1. Apply a light coat of lubricating oil to O-ring **(3)** and install into oil fill port.
2. Insert engine oil fill cap **(1)** into engine block **(2)**.

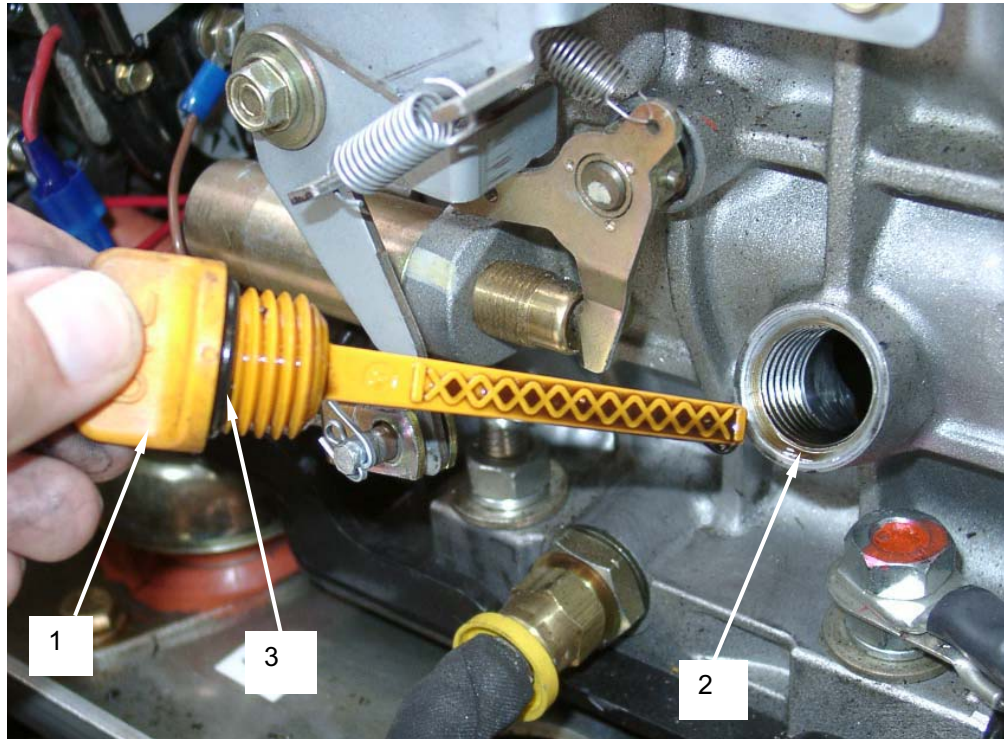

END OF WORK PACKAGE

FIELD (UNIT) MAINTENANCE

LARGE CAPACITY FIELD HEATER (LCFH)

NSN 4520-01-500-1534

OIL FILTER
REMOVE, INSPECT, INSTALL

INITIAL SETUP:

Tools

Tool Kit, General Mechanics (Item 2, WP 0092 00)

Personnel Required

MOS 63J or 52C

Materials/Parts

Oil, engine lubricating (Item 25, WP 0119 00)
Rag, wiping, clean (Item 4, WP 0119 00)

Equipment Condition

Heater shut down and cool.
Engine bay access door open.
Engine oil drained (WP 0046 00).

NOTE

Engine maintenance requires metric tools for the removal of all hardware and assemblies.

**WARNING**

Allow the engine to cool for approximately 30 minutes before changing oil. Engine oil is hot and presents a burn hazard. Coming in contact with hot engine oil may cause burns and severe injury.

NOTE

The oil filter must be cleaned at the same time as the engine oil is changed, since oil escapes when the filter is removed.

REMOVAL

Remove oil filter (1) from crankcase (2) by removing bolt (3) and pulling straight out. Remove and discard O-ring (4).

INSPECTION

1. Inspect oil filter (1) for obvious damage. Check filter's mesh material for damage. Clean out clogging dirt and residue. Replace oil filter as required.
2. Inspect area around oil filter port for evidence of leakage. Clean area of dirt and accumulated grime using a clean rag.

INSTALLATION

1. Apply a light coat of lubricating oil to new O-ring (4) and install O-ring onto oil filter (1).

2. Slide oil filter (1) into crankspace (2) and secure using bolt (3).

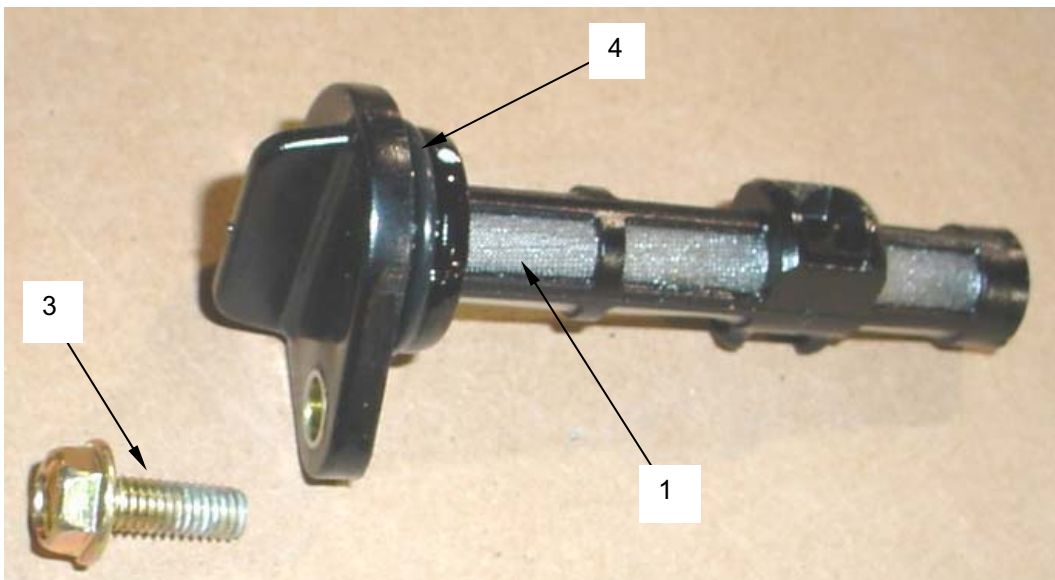
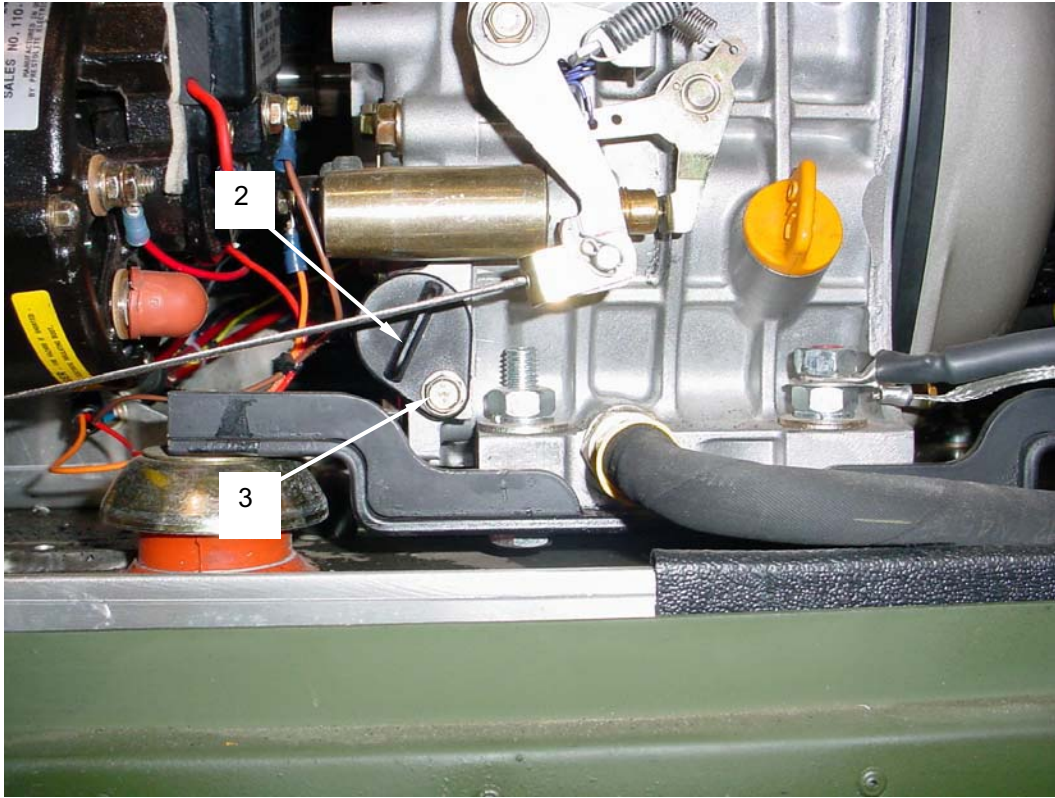

END OF WORK PACKAGE

FIELD (UNIT) MAINTENANCE

LARGE CAPACITY FIELD HEATER (LCFH)

NSN 4520-01-500-1534

COMBUSTION BLOWER
TEST, REPLACE**INITIAL SETUP:****Tools**

Tool Kit, General Mechanics (Item 2, WP 0092 00)

Personnel Required

MOS 63J or 52C

Materials/PartsOil, engine lubricating (Item 25, WP 0119 00)
Rag, cleaning (Item 4, WP 0119 00)**Equipment Condition**Heater shut down and cool.
Engine bay access door open.
Main battery switch OFF and handle removed.**TEST**

1. Remove the combustion blower as detailed in the section of this work package entitled REPLACE.
2. Rotate the combustion blower by hand and ensure that it rotates freely and that there is no binding or scraping.
3. If a 24VDC power supply is available, connect it to the combustion blower and verify that it rotates freely and without binding.
4. Replace a defective combustion blower fan as detailed in the section of this work package entitled REPLACE.

REPLACE

1. Disconnect the combustion blower wiring harness **(1)** by separating the two halves of the connector.
2. Loosen and remove large hose clamp **(2)** and four nuts **(3)** securing plate **(4)** to burner housing. Remove plate from burner housing and set aside with hardware.
3. Remove the eight screws **(5)** and flatwashers **(6)** that secure the combustion blower assembly **(7)** to the combustion fan housing **(8)**.
4. Remove the combustion blower assembly **(7)**.
5. Install a new combustion blower assembly **(7)** by aligning the holes in the combustion blower flange with the holes in the combustion fan housing **(8)**.
6. Install eight screws **(5)** and flatwashers **(6)**. Tighten securely.
7. Install plate **(4)** set aside earlier to burner housing with four nuts **(3)** and large hose clamp **(2)**.
8. Connect the combustion blower wiring harness connector **(1)**.

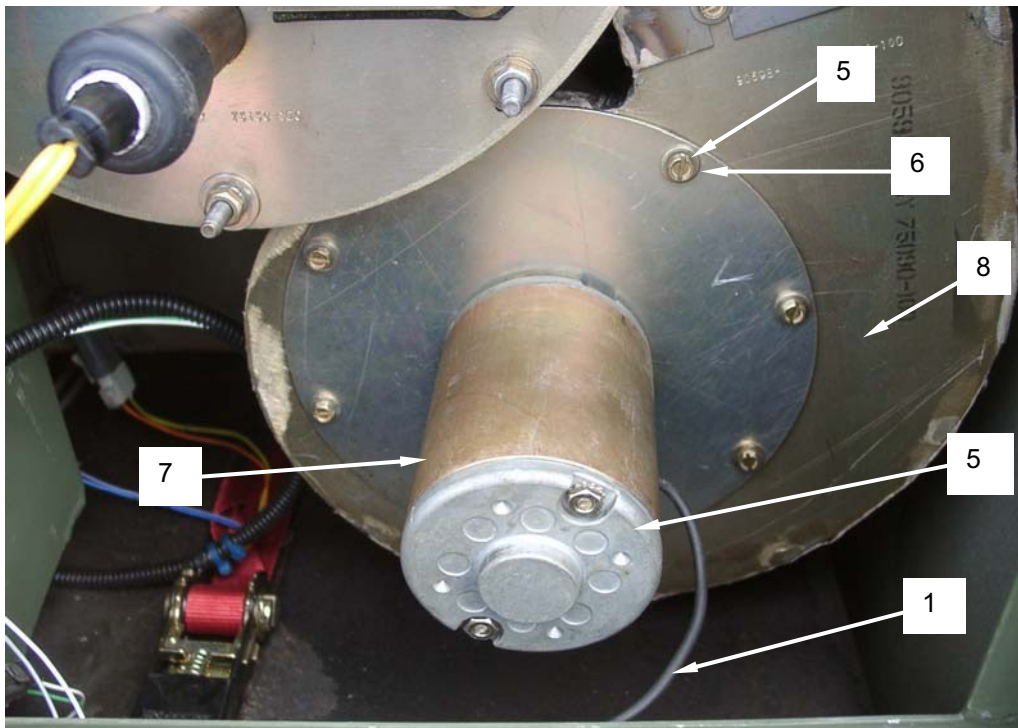
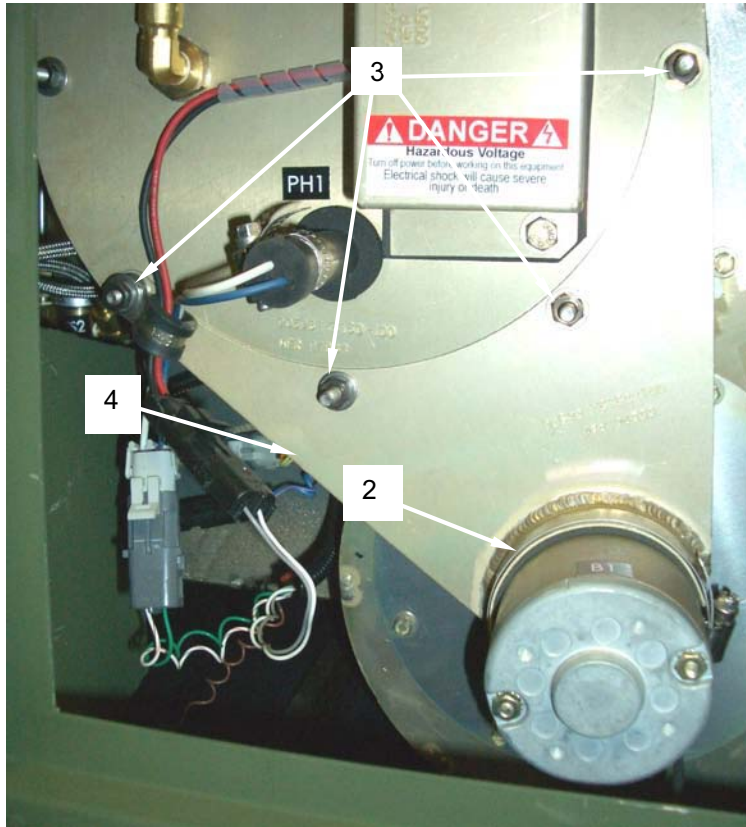

END OF WORK PACKAGE

FIELD (UNIT) MAINTENANCE

LARGE CAPACITY FIELD HEATER (LCFH)

NSN 4520-01-500-1534

BURNER NOZZLE AND ELECTRODE ASSEMBLY
REMOVE, ADJUST, SERVICE, INSTALL, REPLACE

INITIAL SETUP:

Tools

Tool Kit, General Mechanics (Item 2, WP 0092 00)
Tool, Electrode Setting (Item 11, WP 0092 00)
Pads, knee (Item 16, WP 0092 00)

Materials/Parts

Rag, wiping, clean (Item 4, WP 0119 00)

Personnel Required

MOS 63J or 52C (Two personnel or holding device recommended)

Equipment Condition

Heater shut down and cool.
Burner access door open.
Main battery switch OFF and handle removed

REMOVE

1. Loosen clamp **(1)** and remove flame sensor assembly **(2)**. Set flame sensor and clamp aside.
2. Remove the sight glass and coupler assembly **(3)** by grasping coupler with slip joint pliers and turning counterclockwise. Set sight glass and coupler assembly aside.
3. Loosen band clamp **(4)** securing the combustion blower motor **(5)** to combustion air mounting bracket **(6)**.
4. Remove the nuts, lockwashers, flat washers **(7)**, and wiring harness clamp securing the combustion air mounting bracket **(6)** to the upper burner cover **(8)**. Set cover and hardware aside.
5. Slide the combustion air mounting bracket **(6)** back along the combustion blower motor **(5)** to free it from the threaded studs **(9)**. Set mounting bracket and hardware aside.
6. Remove the four nuts, lock washers, flat washers **(10)**, and wiring harness clamp securing the upper burner cover **(8)**.
7. Disconnect ignition pack wire harness **(11)**.
8. Carefully remove upper burner cover **(8)** with ignition pack **(12)** and pressure gauge **(13)** attached.
9. Disconnect the two high voltage ignition cables **(14)** connected to the burner electrode connectors **(15)**.
10. Tag and mark the two fuel lines **(16 and 17)** and pressure gauge line **(18)** in order to identify them properly during the install process.
11. Loosen the fittings **(19, 20, and 21)** and remove the two fuel lines **(16 and 17)** and the pressure gauge line **(18)**. Use a rag to clean up any spilled fuel. Set the burner cover assembly aside.
12. Remove the four nuts, lockwashers, and flat washers **(22)** securing the burner nozzle and electrode assembly **(23)** to the burner cone.

13. Remove the burner nozzle and electrode assembly (23) from the burner cone assembly (24).

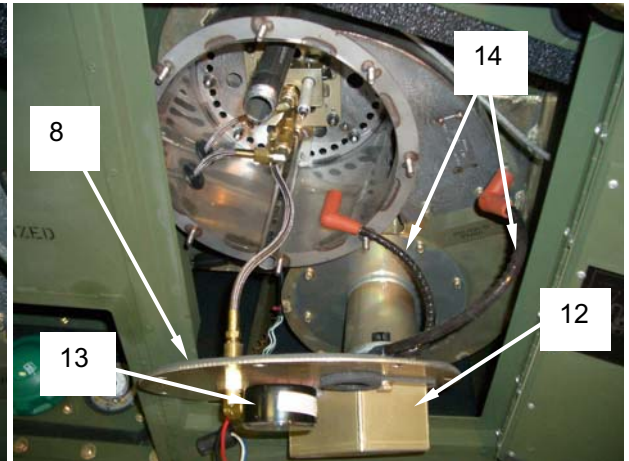
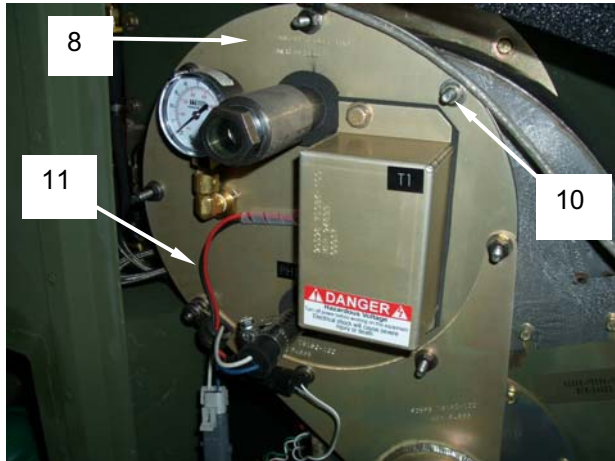
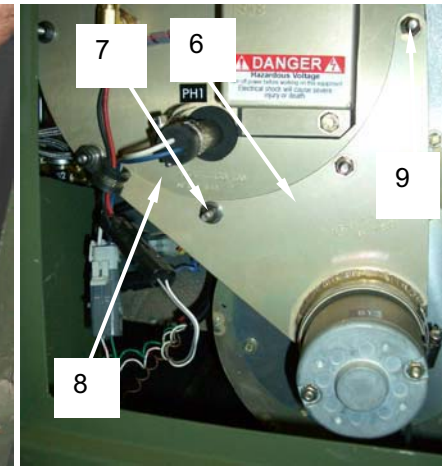
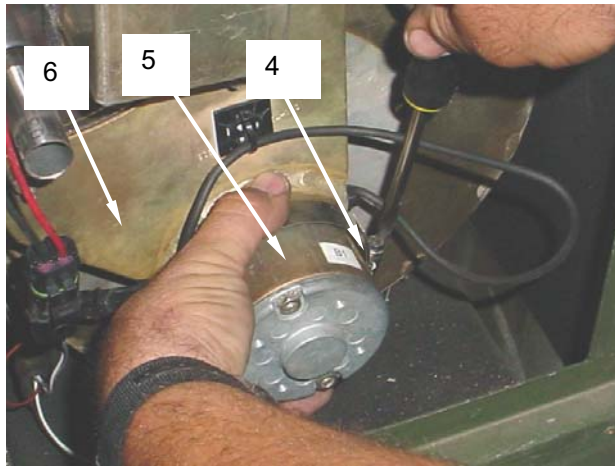
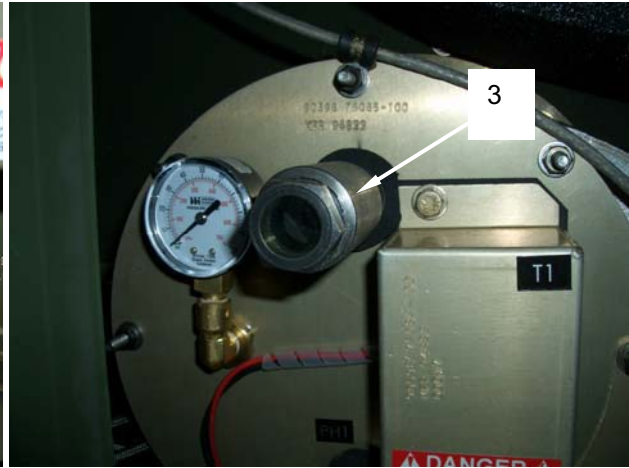
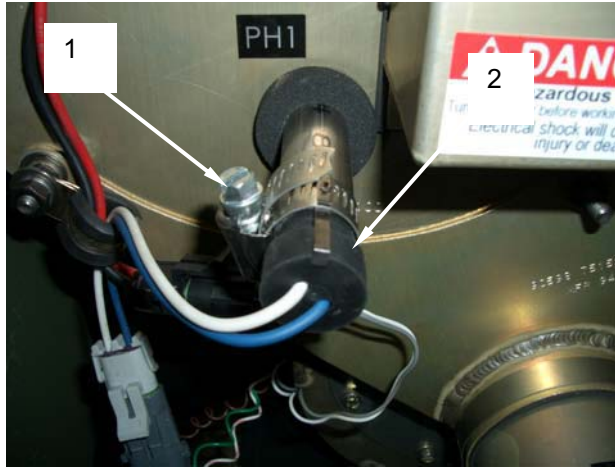

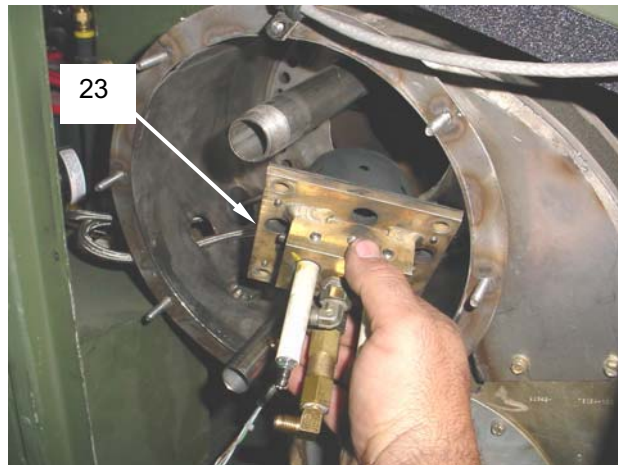
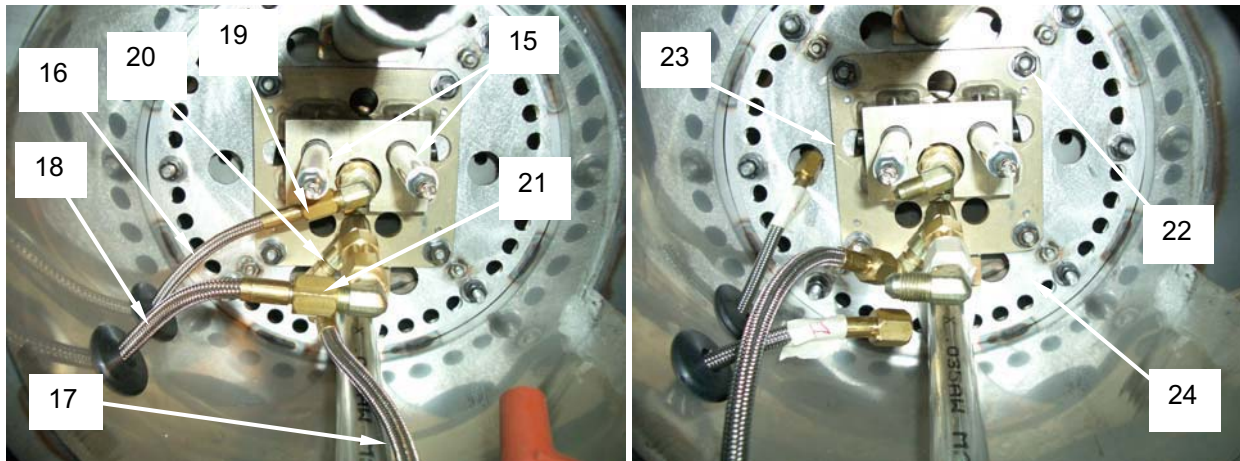

REPLACE

1. If it is necessary to replace the entire burner nozzle and electrode assembly, adjust the electrodes and nozzle of the new assembly as described in the section of this work package entitled ADJUST. Install the adjusted assembly in accordance with the section of this work package entitled INSTALL.
2. If it is necessary to replace only the electrodes or the nozzle separately, remove the defective part, install new part and adjust in accordance with section of this work package entitled ADJUST. Install the adjusted assembly in accordance with the section of this work package entitled INSTALL.

SERVICE

Clean any carbon buildup from swirler (25) with wire brush. Inspect burner cone cavity (26) and dislodge any carbon with screwdriver or similar tool. Collect all debris with rag and dispose of.



Note: Burner cone removed from heater for illustrative purposes only. Do not remove burner cone from heater for cleaning.

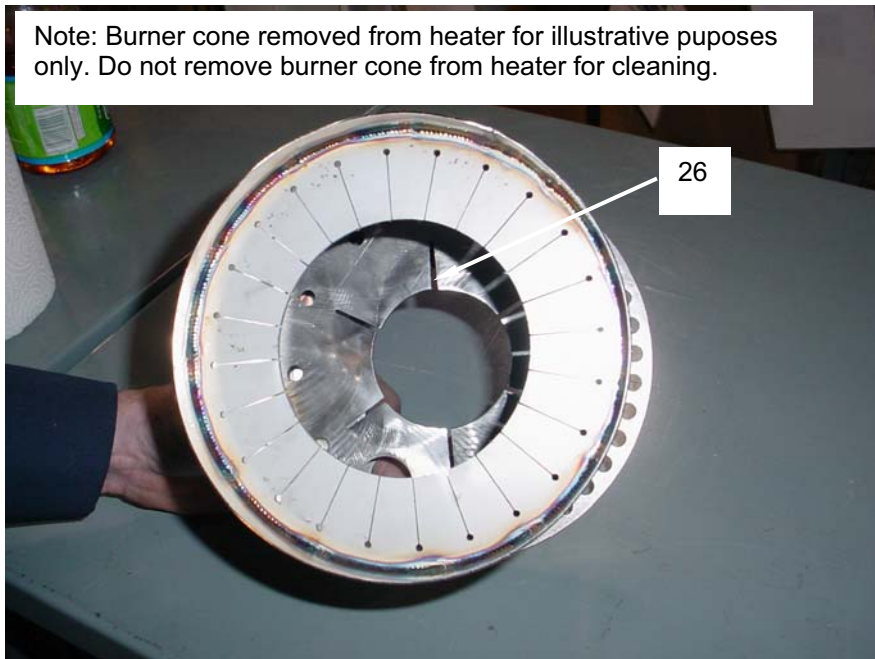

ADJUST**CAUTION**

Do not make adjustments to the burner nozzle and electrode assembly until it is deemed necessary after checking the alignment with the adjusting tool.

NOTE

An electrode gap adjusting tool is required for the proper adjustment of the burner nozzle and electrode assembly. This tool is supplied with each heater and is permanently tethered to the heater inside the fuel system access door, stowed inside the technical manual storage bin. If the electrode gap adjusting tool is lost or damaged, it may be reordered using information found in the RPSTL portion of this TM. As a field expedient, a template is supplied at the end of this work package that can be printed, cut out, and used in place of the tool. This tool is approved for local fabrication; an engineering drawing is provided in the rear matter section of this TM to ensure that the tool is fabricated to exact tolerances.

Checking position of the electrodes and nozzle.

1. Set the burner nozzle and electrode assembly **(23)** on a stable work surface with the burner cone with swirlers **(25)** facing toward you.
2. Verify that all of the conditions listed below exist. If all conditions exist, the burner nozzle and electrode assembly does not require adjustment. Proceed to the section of this work package entitled SERVICE and performed the indicated tasks followed by INSTALL. If **ANY** of the conditions do not exist, adjustment is required as detailed in the section below entitled "Adjusting the position of the electrodes and nozzle".
3. Insert the supplied electrode gap adjusting tool **(27)** so that it falls between the tips **(28 and 29)** of the two electrodes and the angled shoulders **(30)** of the tool are in contact with the inner ring **(31)** of the burner cone with swirlers **(25)**. Verify that the tip of the nozzle **(32)** is in contact with the end **(33)** of the electrode adjusting tool without raising the adjusting tool off the inner ring **(31)** of the burner cone with swirlers **(25)**. Verify also that the center of the tip of the nozzle **(32)** is aligned with the center line **(34)** of the adjusting tool **(27)**. This line is labeled "C/L Nozzle" (C/L = Center Line).
4. Rotate the adjusting tool **(27)** 90 degrees and position the angled shoulders **(30)** of the tool so that they are in contact with the inner ring **(31)** of the burner cone with swirlers **(25)**. Verify again that the center of the nozzle **(32)** is aligned with the center line **(34)** of the adjusting tool.
5. Move the adjusting tool **(27)** so that it is in contact with the tips of the electrodes **(28 and 29)** and centered over the center of the nozzle **(32)**. Verify that the tips of the electrodes **(28 and 29)** are aligned with the two indicator lines **(35 and 36)** and that the electrodes are positioned the correct distance from the end of the nozzle by verifying that the tips of the electrodes are aligned with the horizontal lines **(37 and 38)** of the crosshairs.

Adjusting the position of the electrodes and nozzle.**NOTE**

Two personnel or a holding device are recommended for this section of the maintenance procedure as it will make the adjustment process easier.

ADJUST continued

1. Insert the supplied electrode gap adjusting tool (27) so that it falls between the tips (28 and 29) of the two electrodes and the angled shoulders (30) of the tool are in contact with the inner ring (31) of the burner cone with swirlers (25). Verify that the tip of the nozzle (32) is in contact with the end (33) of the electrode adjusting tool without raising the adjusting tool off the inner ring (31) of the burner cone with swirlers (25). Verify also that the center of the tip of the nozzle (32) is aligned with the center line (34) of the adjusting tool (27). This line is labeled "C/L Nozzle" (C/L = Center Line). If the nozzle is not in the correct position, loosen the three nozzle adjustment screws (39, 40, and 41) and move the nozzle so that it is aligned with the centerline (34). Tighten the nozzle adjustment screws just enough to hold the nozzle in position.
2. Rotate the adjusting tool (27) 90 degrees and position the angled shoulders (30) of the tool so that they are in contact with the inner ring (31) of the burner cone with swirlers (25). Verify again that the center of the nozzle is aligned with the center line (34) of the adjusting tool. If the nozzle is not in the correct position, loosen the three nozzle adjustment screws (39, 40, and 41) once again and move the nozzle (32) so that it is aligned with the centerline (34). Alternate the position of the adjusting tool back and forth 90 degrees to ensure that the nozzle is centered along two axes. Once alignment is verified, tighten the nozzle adjustment screws (39, 40, and 41) securely.
3. With the adjusting tool (27) positioned so that it is in contact with both electrode tips (28 and 29), verify that the gap between the electrode tips is correct by aligning with the two indicator lines (35 and 36) on the adjusting tool (27). Verify also that the electrode tips are the correct distance from the end of the nozzle by verifying that the tips of the electrodes are aligned with the horizontal lines (37 and 38) of the crosshairs.
4. If the electrodes are out of alignment, loosen the allen set screw (42) for the right hand electrode (43) and position the electrode so that it is aligned with the indicator line (36) to the right of center and at the same level as the horizontal line (38) of the crosshair. Tighten the allen set screw (42).
5. Check the alignment of the left hand electrode tip (28). If not aligned with the indicator line (35) to the left of center, loosen the allen set screw (44) for the left hand electrode (45) and set the electrode gap so that it is aligned with the indicator line (35) to the left of center and at the same level as the horizontal line (37) of the crosshair. Tighten the allen set screw (44).

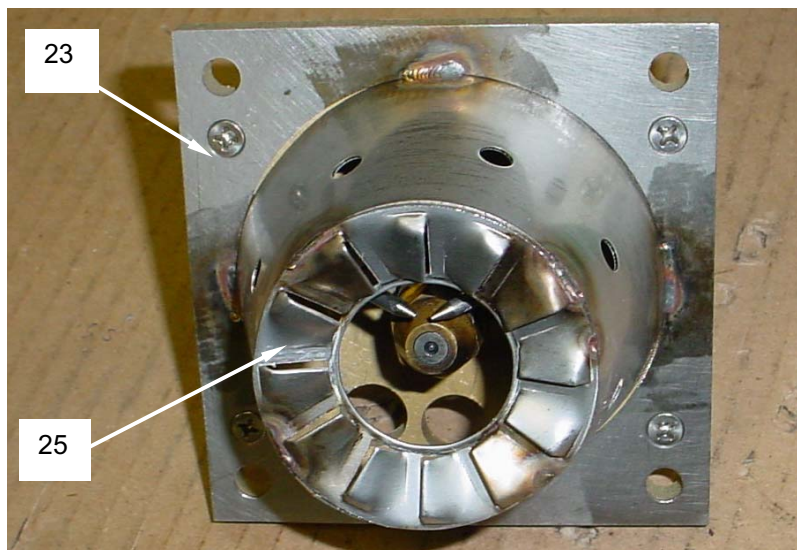

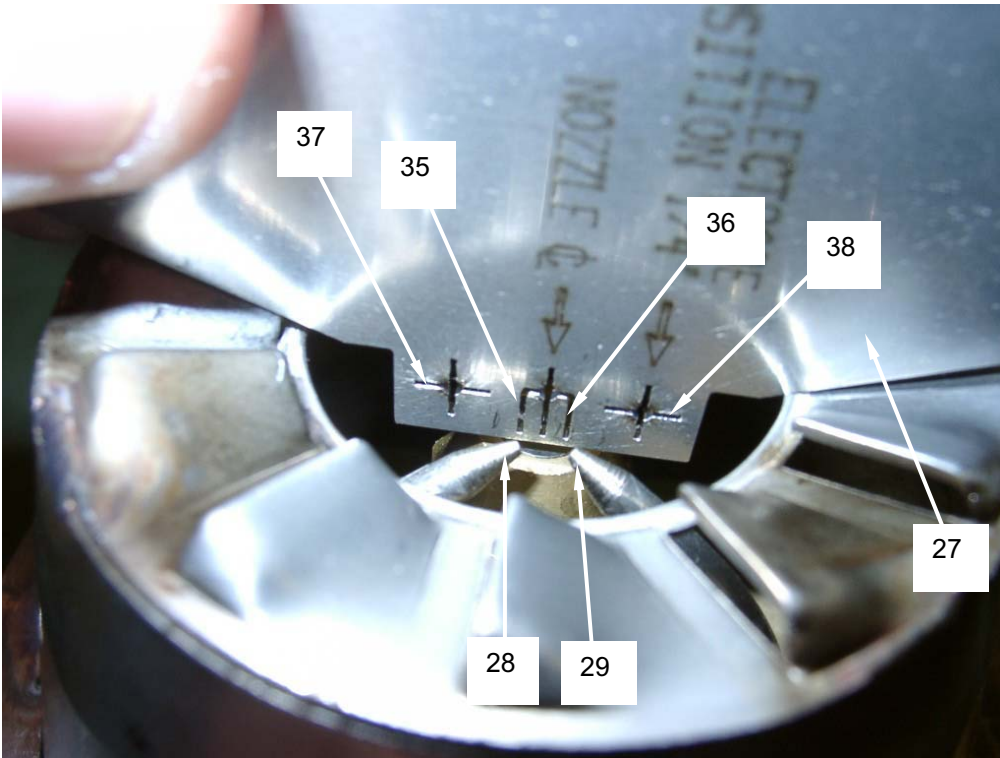
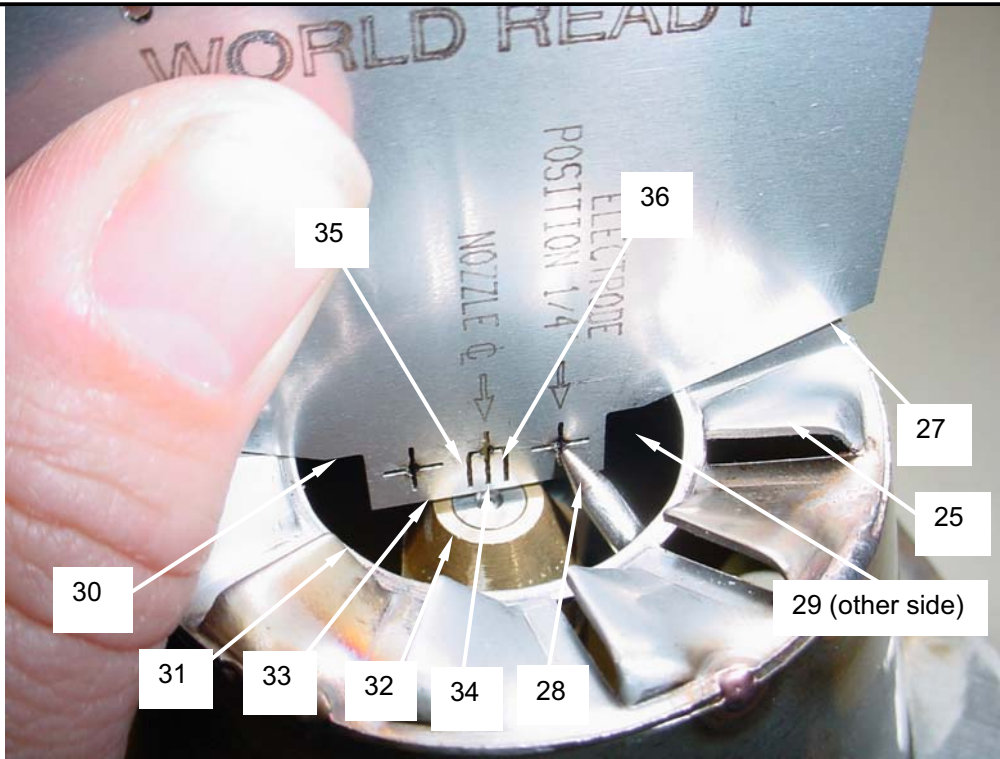

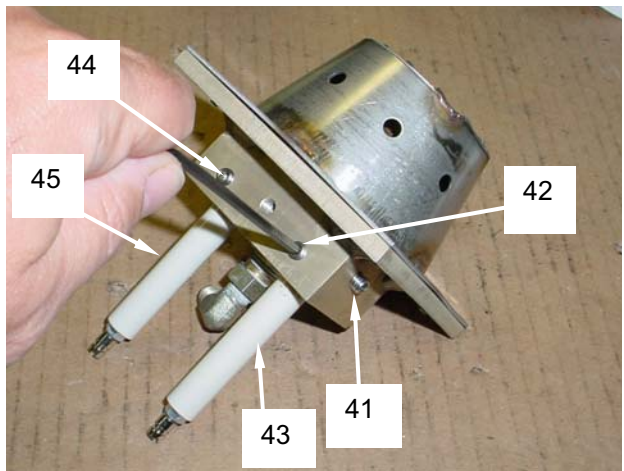
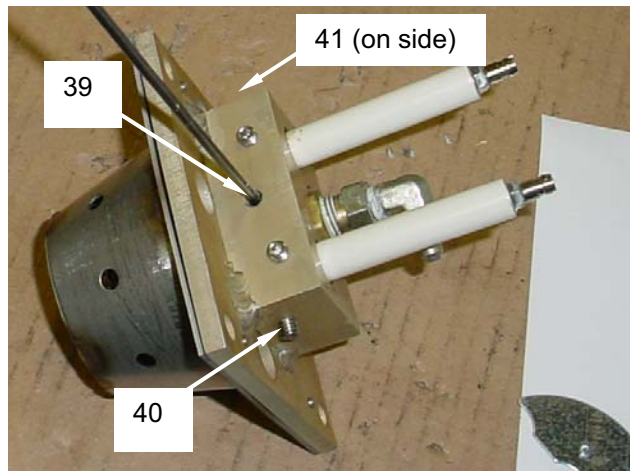
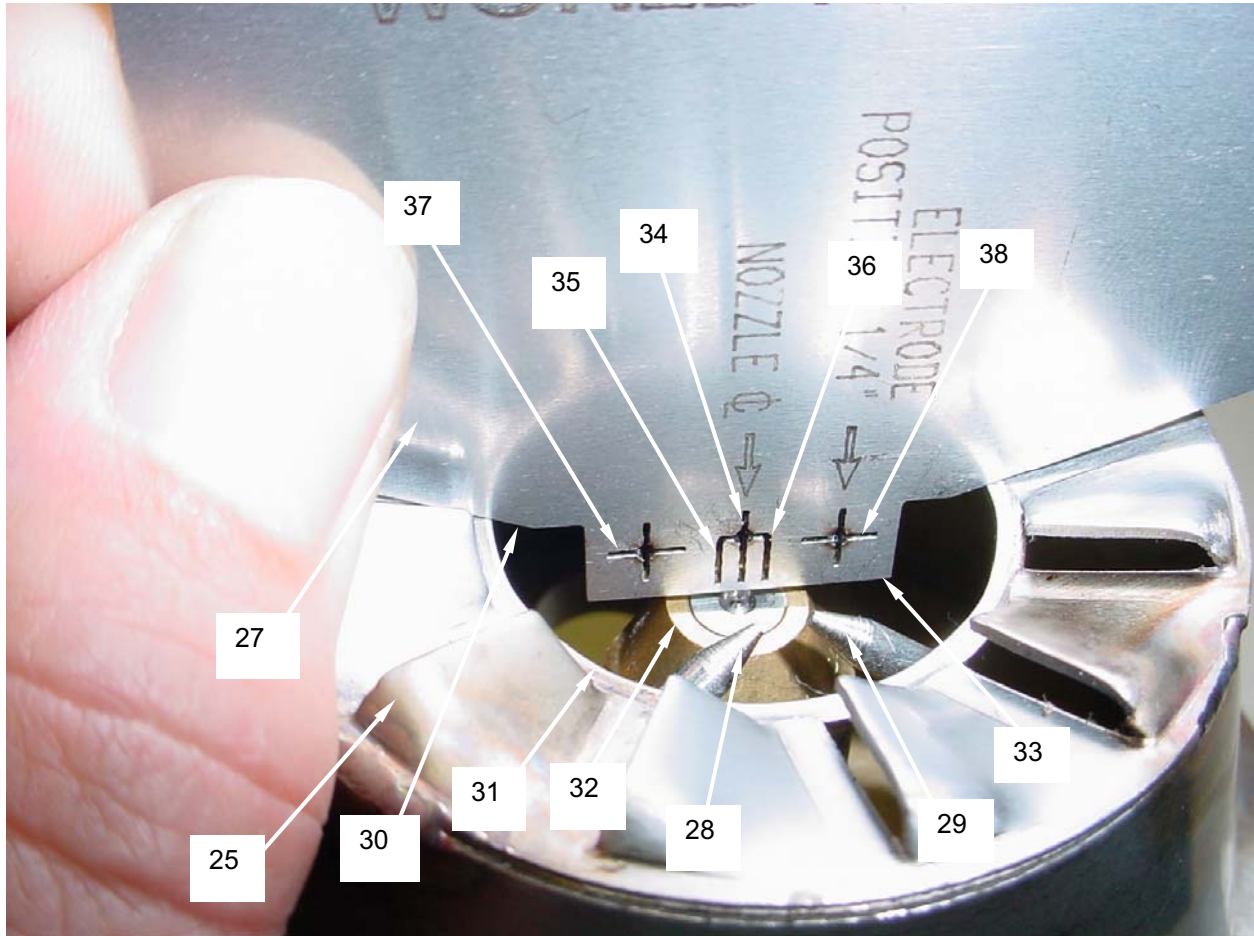

INSTALL

1. Position burner nozzle and electrode assembly (23) in burner cone assembly (24) and install the four nuts, lock washers, and flat washers (22) that secure the burner nozzle and electrode assembly (23) to the burner cone assembly (24).
2. Install the two fuel lines (16 and 17) and the pressure gauge line (18). Tighten fittings (19, 20, and 21) securely.
3. Connect the two high voltage ignition cables (14) to the burner electrode connectors (15).
4. Position the upper burner cover (8) with ignition pack (12) and pressure gauge (13) attached so that the burner sight glass fitting (46) passes through the hole in the cover (8) and the threaded studs (9) pass through the holes in the cover.
5. Install the upper four nuts, lock washers, flat washers (10), and wire harness clamp securing the upper burner cover (8).
6. Reconnect ignition pack wire harness (11).
7. Slide the combustion air mounting bracket (6) back into position over the four lower threaded studs (9).
8. Install the four nuts, lock washers, flat washers (7), and wire harness clamp securing the combustion air mounting bracket (6) to the upper burner cover (8).
9. Tighten the band clamp (4) securing the combustion blower motor (5) to combustion air mounting bracket (6).
10. Install the sight glass and coupler assembly (3) by grasping coupler with slip joint pliers and turning clockwise.
11. Install flame sensor assembly (2) and secure with clamp (1).

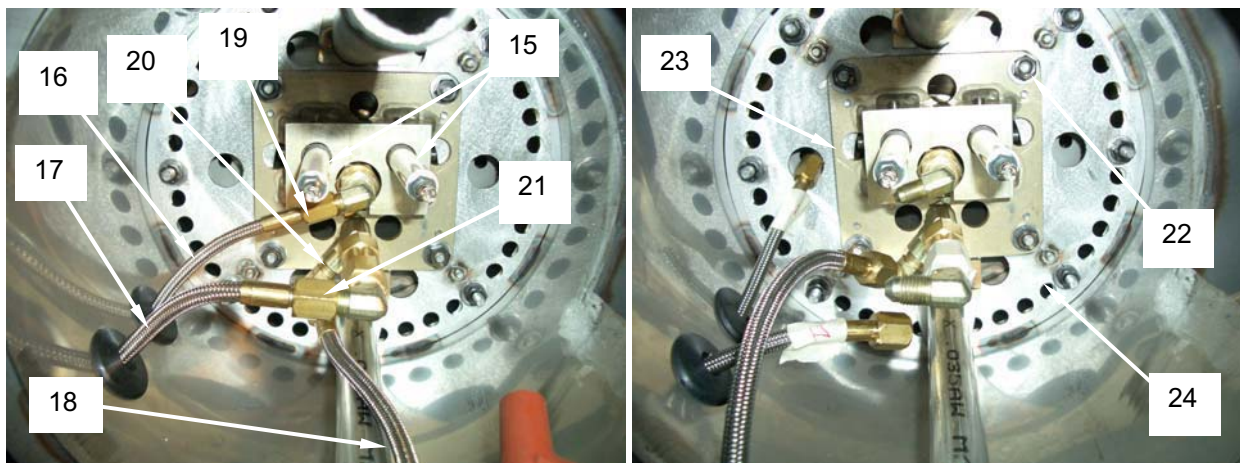

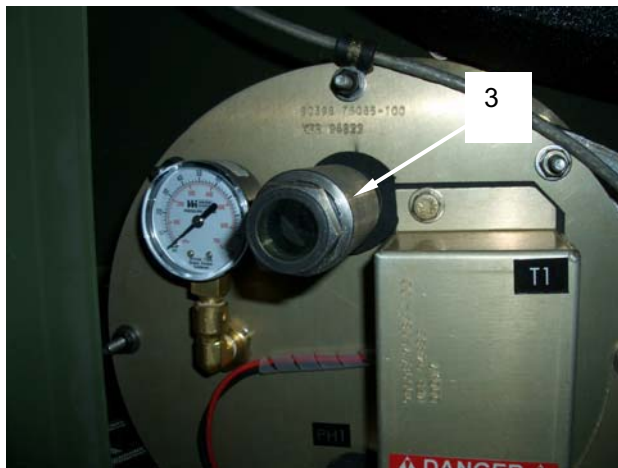
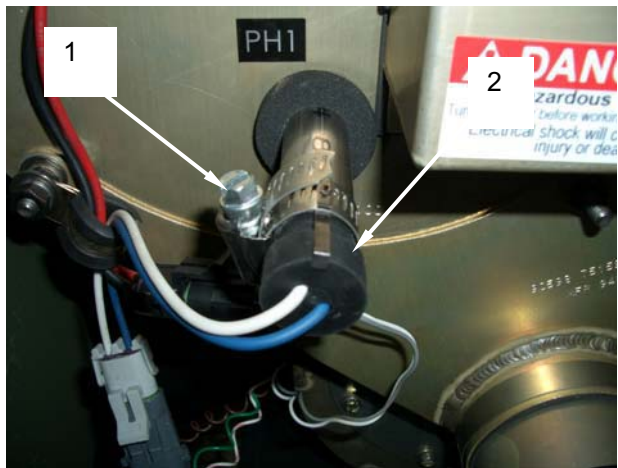
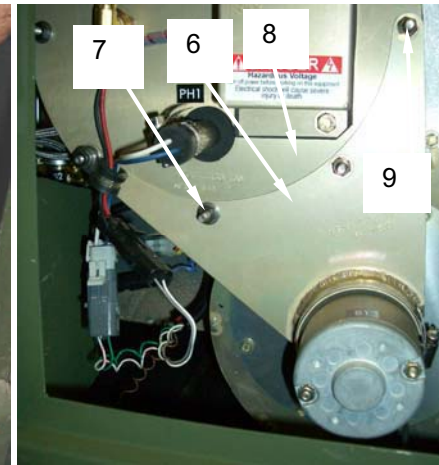
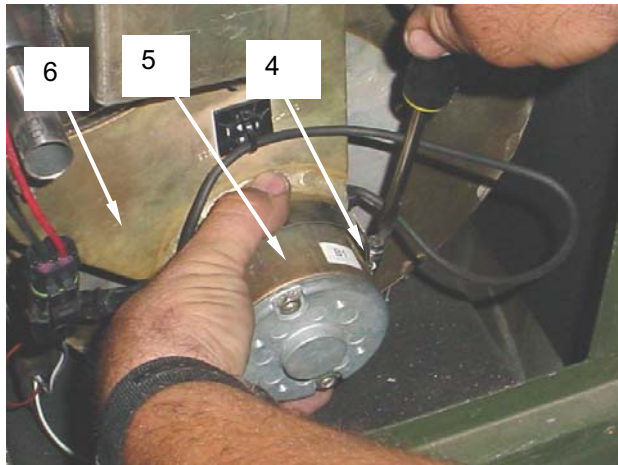
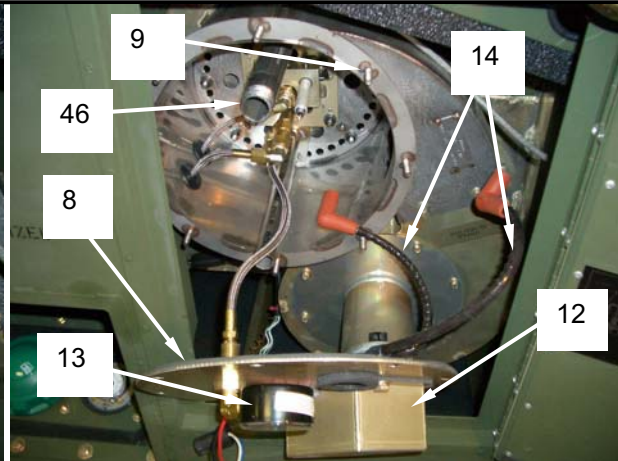
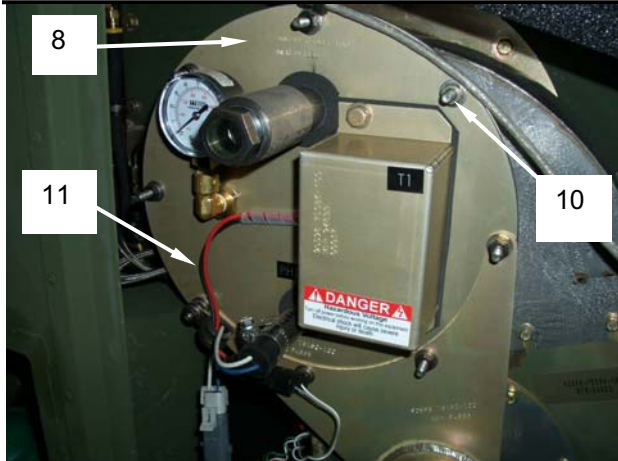

ELECTRODE AND NOZZLE GAP ADJUSTMENT TOOL TEMPLATE

The template below is provided in the event that the electrode and nozzle adjustment tool permanently tethered to the heater inside the burner access door has been damaged or lost. It is preferable to reorder the adjusting tool using information provided in the RPSTL portion of this TM or to fabricate the tool locally using the engineering drawing provided in the rear matter section of this TM. If the paper template is used, it should be printed on card stock to improve rigidity and reproduced at its actual size. Once printed, verify that the tool has been reproduced correctly by measuring the distance between the points identified below. The distance between the points indicated should be exactly 0.25 inches.

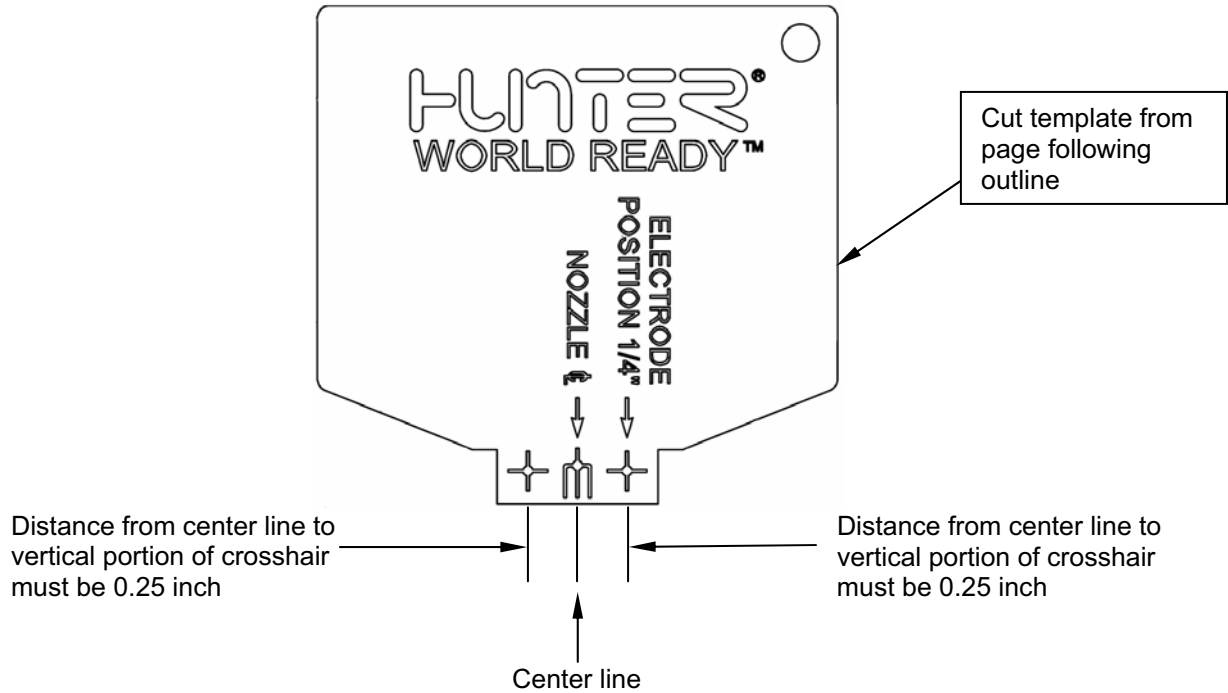

END OF WORK PACKAGE

FIELD (UNIT) MAINTENANCE**LARGE CAPACITY FIELD HEATER (LCFH)****NSN 4520-01-500-1534****BURNER CONE ASSEMBLY
INSPECT, SERVICE, REPLACE**

INITIAL SETUP:**Tools**

Tool Kit, General Mechanics (Item 2, WP 0092 00)

Personnel Required

MOS 63J or 52C

Materials/Parts

Rag, wiping, clean (Item 4, WP 0119 00)

Equipment ConditionHeater shut down and cool.
Engine bay access door open.
Main battery switch OFF and handle removed
Remove burner nozzle and electrode assy (WP 0050 00)

INSPECT

1. Remove burner nozzle and electrode assembly IAW WP 0050 00.
2. Inspect the interior of the burner cone assembly **(1)** for excessive amounts of carbon or other combustion debris. If found, clean the interior of the burner cone assembly as detailed in the section of this work package entitled SERVICE.
3. Inspect the inside of the burner cone assembly **(1)** and ensure that the interior is not cracked or otherwise damaged. If damage is found, replace as detailed in the section of this work package entitled REPLACE.
4. Install burner nozzle and electrode assembly IAW WP 0050 00.

SERVICE

1. Remove burner nozzle and electrode assembly IAW WP 0050 00.
2. Clean inside of the burner cone assembly **(1)** for pieces of carbon. Scrape with a screwdriver, wire brush, or similar tool taking care not to damage burner cone assembly.
3. Collect any debris in a rag and dispose of properly.
4. Install burner nozzle and electrode assembly IAW WP 0050 00.

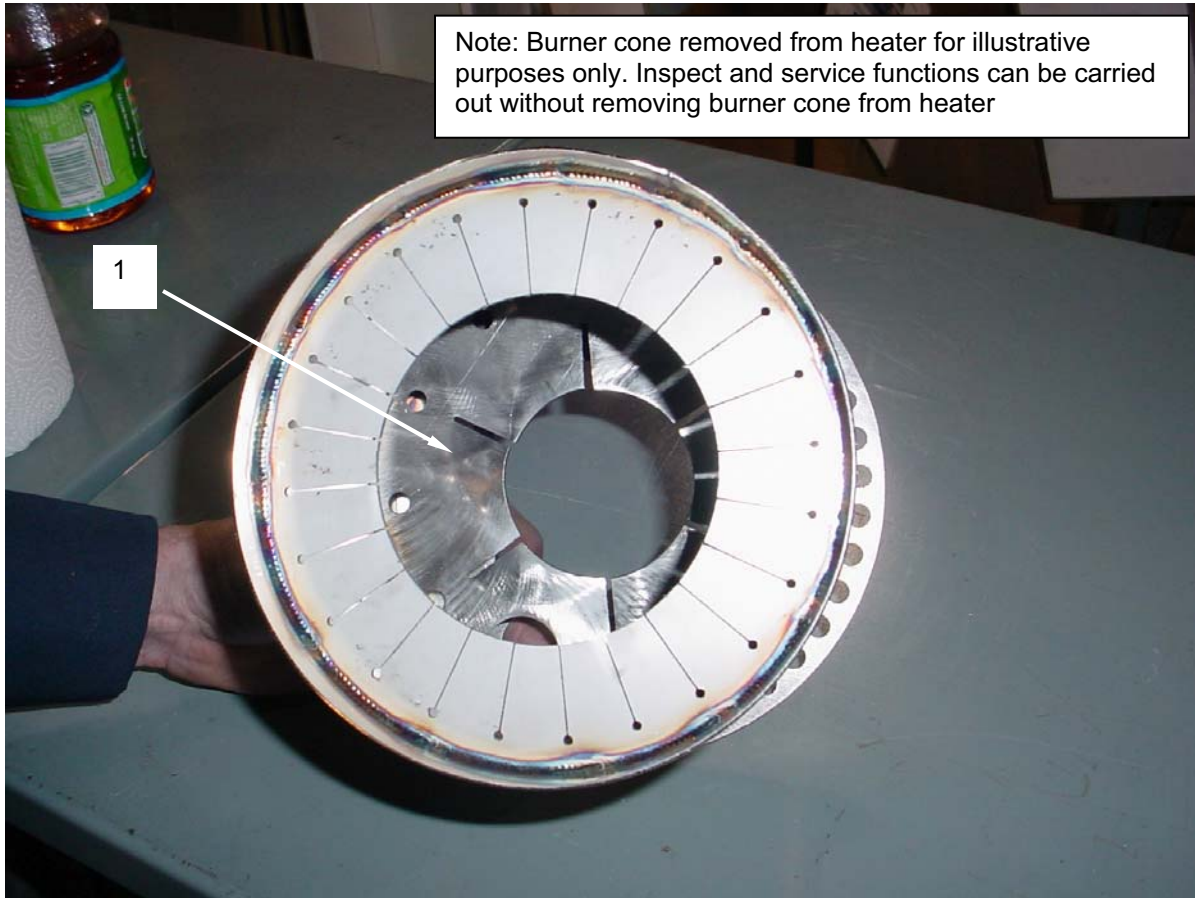

REPLACE

1. Remove burner nozzle and electrode assembly IAW WP 0050 00.
2. Remove the eight nuts, lockwashers, and flat washers (1) securing the burner cone assembly (2) to the heat exchanger (3). Set hardware aside.
3. Pull the burner cone assembly (2) from the heat exchanger (3).
4. With the burner cone removed, inspect the spiral-shaped interior of the heat exchanger (3) and ensure that there are no signs of wear such as deformation of the metal, cracks, etc. If signs of wear or damage are found that would adversely affect the integrity of the assembly, replace the heat exchanger IAW WP 0054 00.
5. Install a new burner cone assembly (2) in the same orientation as before.
6. Secure with eight nuts, lockwashers, and flat washers (1) set aside earlier.
7. Install the burner nozzle and electrode assembly IAW WP 0050 00.

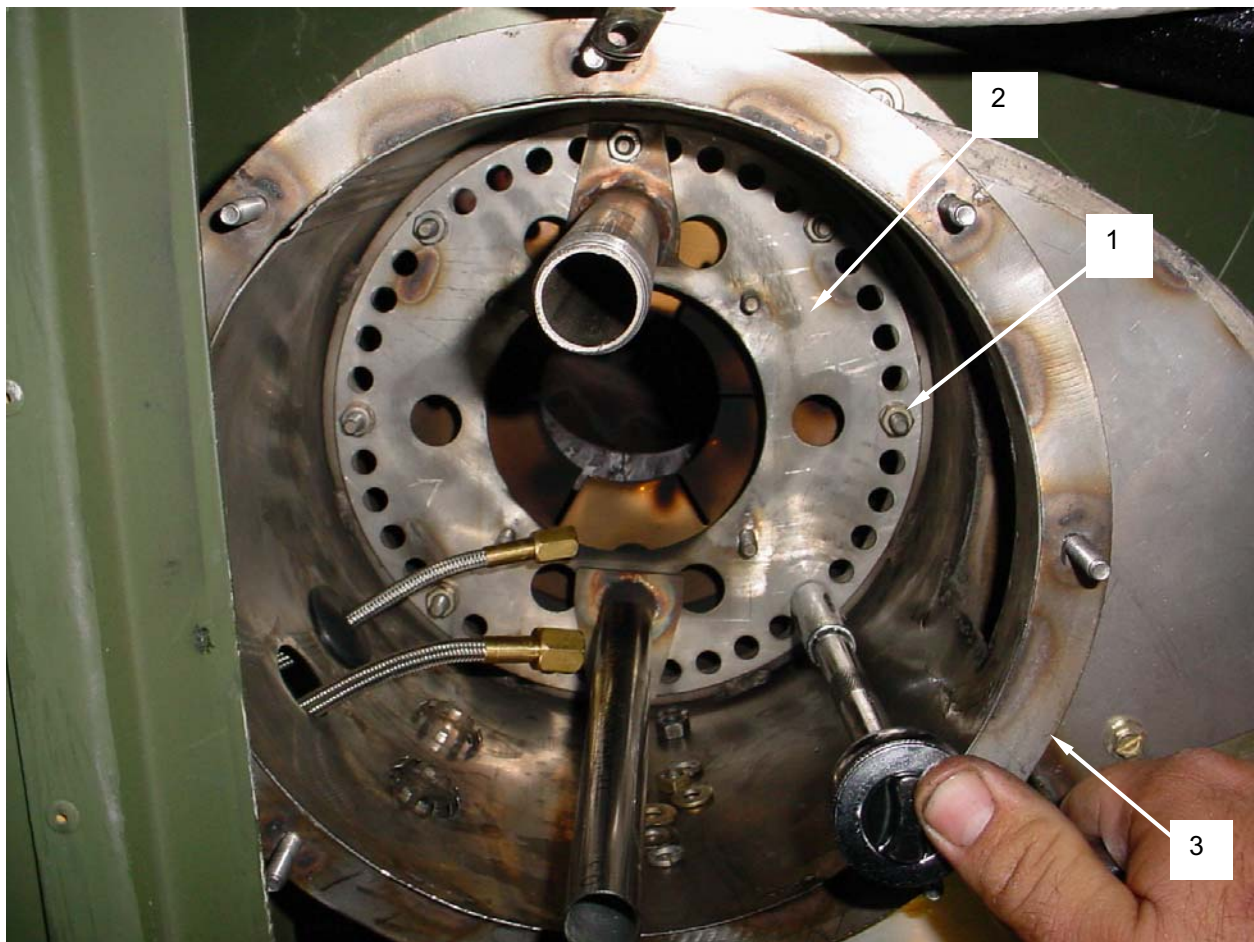
**END OF WORK PACKAGE**

FIELD (UNIT) MAINTENANCE

LARGE CAPACITY FIELD HEATER (LCFH)

NSN 4520-01-500-1534

IGNITION ASSEMBLY
REPLACE

INITIAL SETUP:

Tools

Tool Kit, General Mechanics (Item 2, WP 0092 00)

Personnel Required

MOS 63J or 52C

Materials/Parts

Tags, marking (Item 5, WP 0119 00)

Equipment Condition

Heater shut down and cool.
Main Battery Shutoff Switch to OFF position and handle removed.
Burner access door open.

REPLACE

**WARNING**

Electrical high voltage cannot be seen but it can kill you, render you unconscious, or severely burn you. Electricity is unlike most other dangerous things you can come in contact with because it gives no warning and no symptoms to be wary of. To ensure your safety and that of other maintenance personnel, always observe the following precautions:

The LCFH must be electrically grounded. Failure to ground the LCFH may result in serious injury or death from electrical malfunction.

- DO NOT perform any maintenance on electrical equipment unless all power is removed.
- BE CERTAIN that there is someone assisting you who can remove power immediately.
- ALWAYS place POWER OFF warning tags on power supply switches so that no one will apply power while you are performing maintenance.
- FOR ARTIFICIAL RESPIRATION, REFER TO FM 21 –11.

1. Move the main battery shutoff switch to the OFF position and remove handle.
2. Disconnect ignition pack wiring harness (1) by separating the connector.
3. Remove the two hex head cap screws (2), flat washers (3), and lock washers (4).
4. Pull ignition pack (5) partially out of burner cover (6) and tag the two high tension cables (7 and 8) as to their connection location on the ignition pack (5).

5. Disconnect the two high tension cables (7 and 8) from the ignition pack (5).
6. Remove the defective ignition pack (5).
7. Install a new ignition pack (5) by positioning it near the burner cover (6) and reconnecting the high tension cable assemblies (7 and 8) in accordance with the tags made earlier.
8. Align the ignition pack holes with the holes in the burner cover (6) and install the two hex head cap screws (2), flat washers (3), and lock washers (4). Tighten securely.
9. Reconnect the ignition pack wiring harness (1).
10. Remove all tags and/or markings.

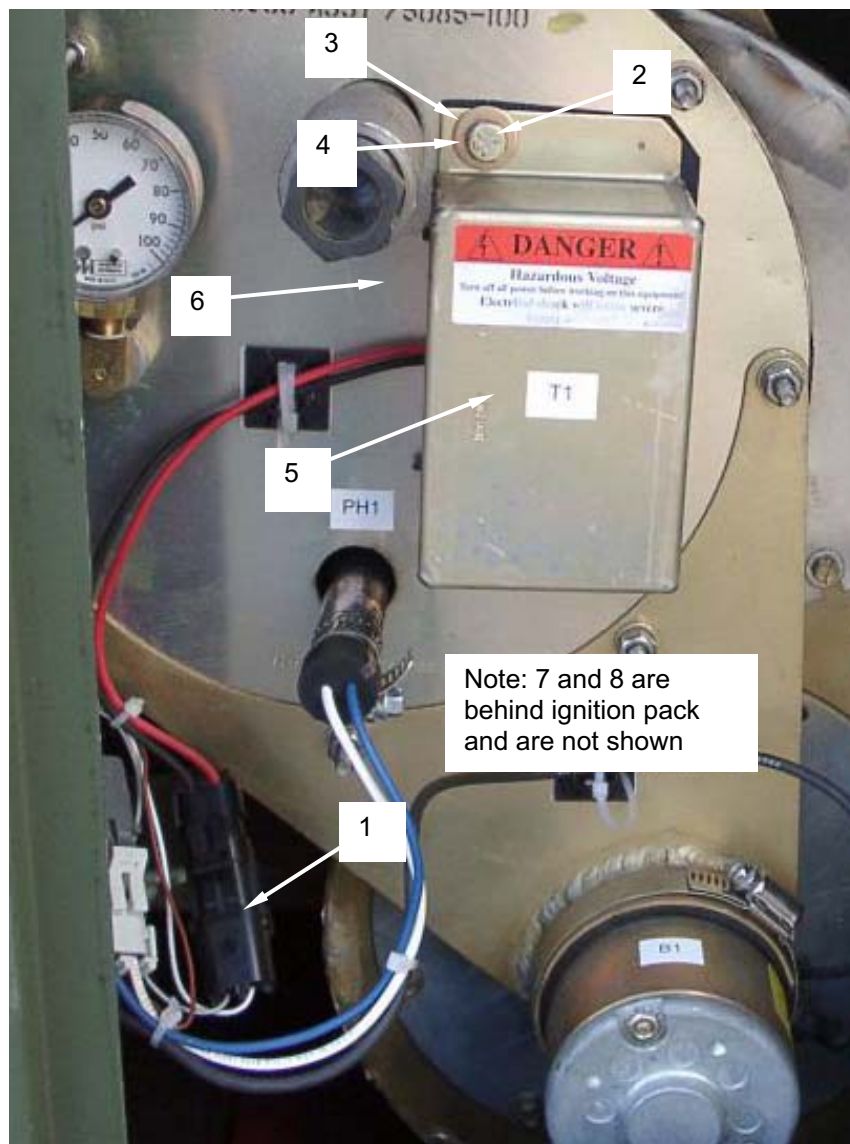

END OF WORK PACKAGE

FIELD (UNIT) MAINTENANCE**LARGE CAPACITY FIELD HEATER (LCFH)****NSN 4520-01-500-1534****FLAME SENSOR
INSPECT, TEST, REPLACE**

INITIAL SETUP:**Tools**

Tool Kit, General Mechanics (Item 2, WP 0092 00)

Personnel Required

MOS 63J or 52C

Materials/Parts

Rags, Wiping, Clean (Item 4, WP 0119 00)

Equipment ConditionHeater shut down and cool.
Main battery switch OFF and handle removed
Burner access door open.

INSPECT

1. Inspect the flame sensor wiring harness **(1)** to ensure that the wires are not damaged in any way and that the insulation has not been scraped away. Ensure that the connector **(2)** is firmly engaged.
2. Loosen clamp **(3)** and remove flame sensor from flame sensor tube **(4)** attached to burner head.
3. Inspect glass face of flame sensor. If dirty, wipe with clean soft cloth.
4. Install flame sensor **(5)** in flame sensor tube **(4)** attached to burner head and tighten clamp **(3)**.

TEST

1. Remove flame sensor **(5)** from flame sensor tube **(4)** attached to burner head by loosening clamp **(3)**.
2. Disconnect flame sensor connector **(2)**.
3. Connect multimeter test leads to blue and white flame sensor leads **(1)**. Set multimeter to read resistance.
4. Hold open end of flame sensor **(5)** towards a light source (a 60 watt light bulb or direct sunlight). The resistance indicated on the ohmmeter should be low.
5. Block off light completely by covering the open end of the flame sensor **(5)**. Within 10 seconds the resistance indicated should be high.
6. Replace flame sensor **(5)** if there is no change in resistance during this procedure.
7. If flame sensor **(5)** meets above tests, install flame sensor from flame sensor tube **(4)** attached to burner head by tightening clamp **(3)**.

REPLACE

1. Disconnect the flame sensor wiring harness (1) by separating the connector (2).
2. Loosen the clamp (3) on the flame sensor tube (4) and slide the clamp (3) up the wiring harness (1).
3. Remove the flame sensor (5) to the flame sensor tube (4).
4. Install a new flame sensor (5) by inserting into the flame sensor tube (4). Press the flame sensor (5) into the end of the flame sensor tube (4) securely.
5. Install the clamp (3) over the wiring harness (1) and position it over the end of the flame sensor tube (4). Tighten clamp securely.
6. Reconnect the flame sensor wiring harness connector (2).

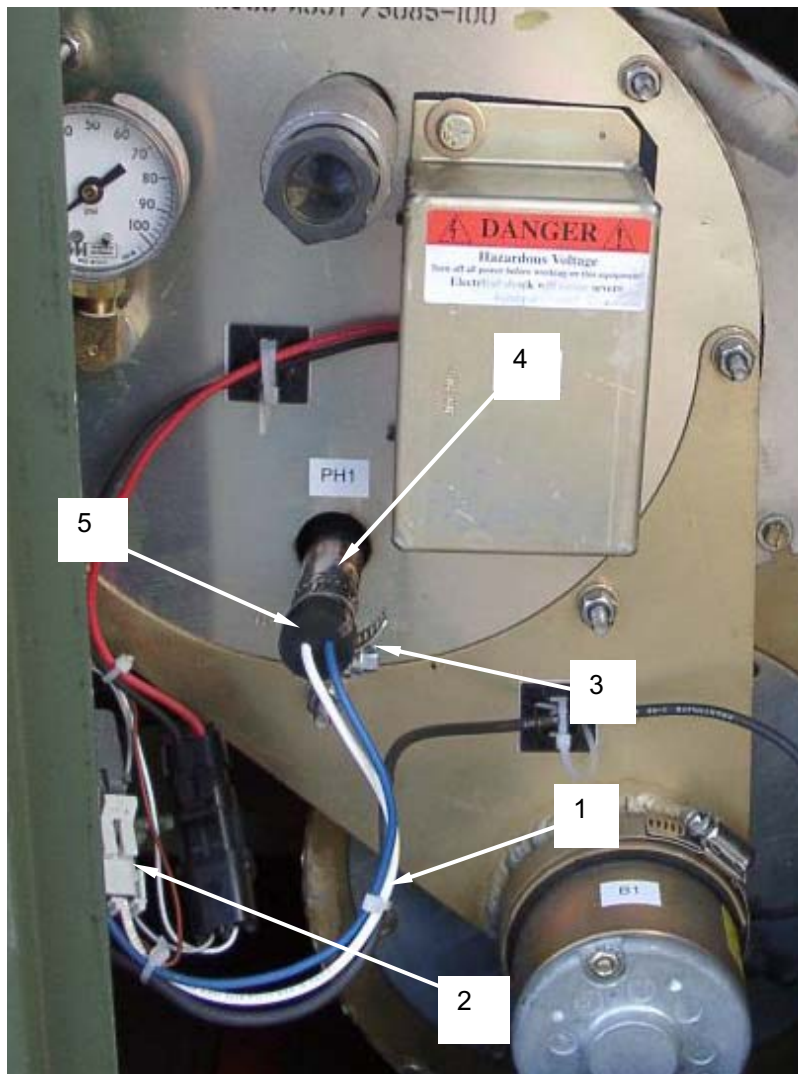
**END OF WORK PACKAGE**

LARGE CAPACITY FIELD HEATER (LCFH)

NSN 4520-01-500-1534

HEAT EXCHANGER
INSPECT, SERVICE, REPLACE

INITIAL SETUP:

Tools

Tool Kit, General Mechanics (Item 2, WP 0092 00)

Personnel Required

MOS 63J or 52C (Qty 2) or lifting aid

Materials/Parts

None required

Equipment Condition

Heater shutdown and cool (WP 0005 00)
Main battery switch OFF and handle removed

INSPECT

1. Remove the heater exchanger access cover (1) by removing the 16 bolts, lockwashers, and flat washers (2) that secure the top of the access cover. This includes the 2 bolts, lockwashers, and flat washers (3) that are located just under the operator control box stowage door.
2. Open the burner access panel and also remove the 6 bolts, lockwashers, and flat washers (4) that secure the access cover underneath the operator control box stowage area.

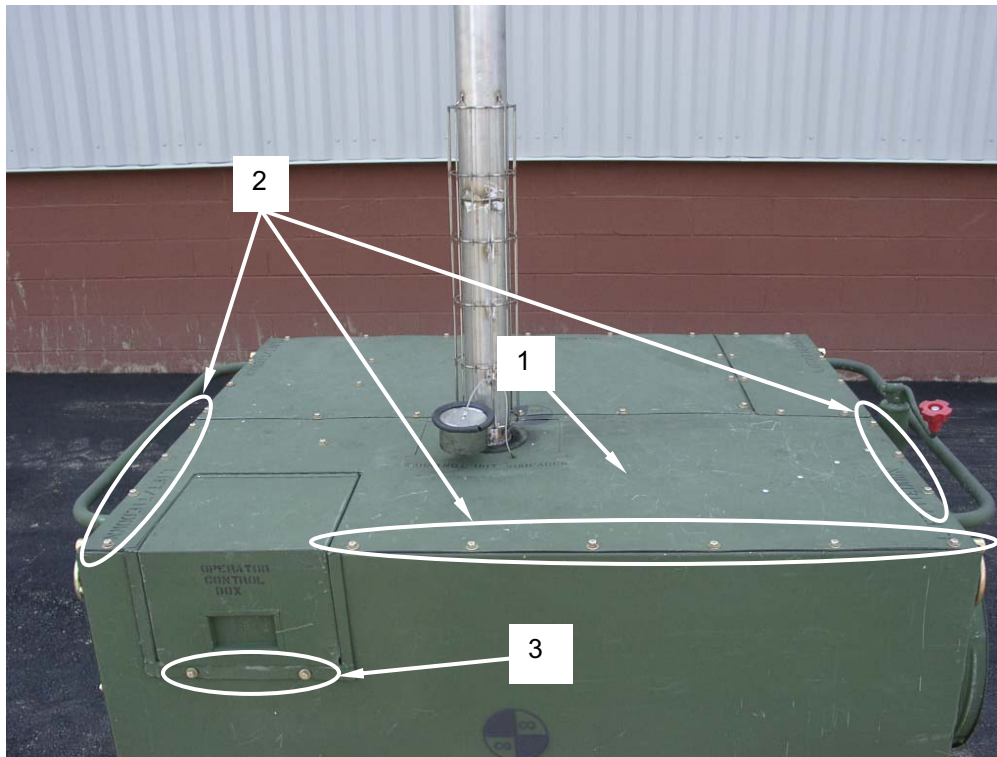

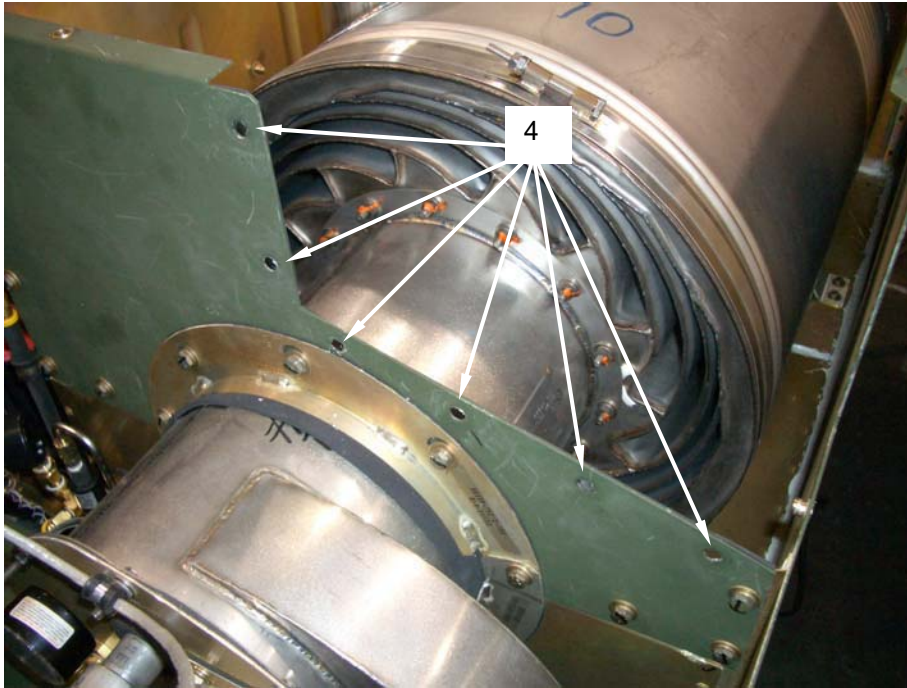

3. Inspect the band clamps **(1)** that secure the heat exchanger **(2)** to the cabinet **(3)**. Ensure that clamps **(1)** are not damaged. Ensure that clamp bolts **(4)** are securely tightened.
4. Inspect the weld seams on the heat exchanger **(2)** and ensure that they are not cracked or corroded in any way.
5. Inspect the overall surface of the heat exchanger **(2)** and ensure that there is no corrosion, holes, or other damage that would affect the overall integrity of the assembly.
6. Inspect the exhaust tube **(5)** that connects the heat exchanger with the cabinet side wall **(6)** is attached securely and is not damaged in any way.

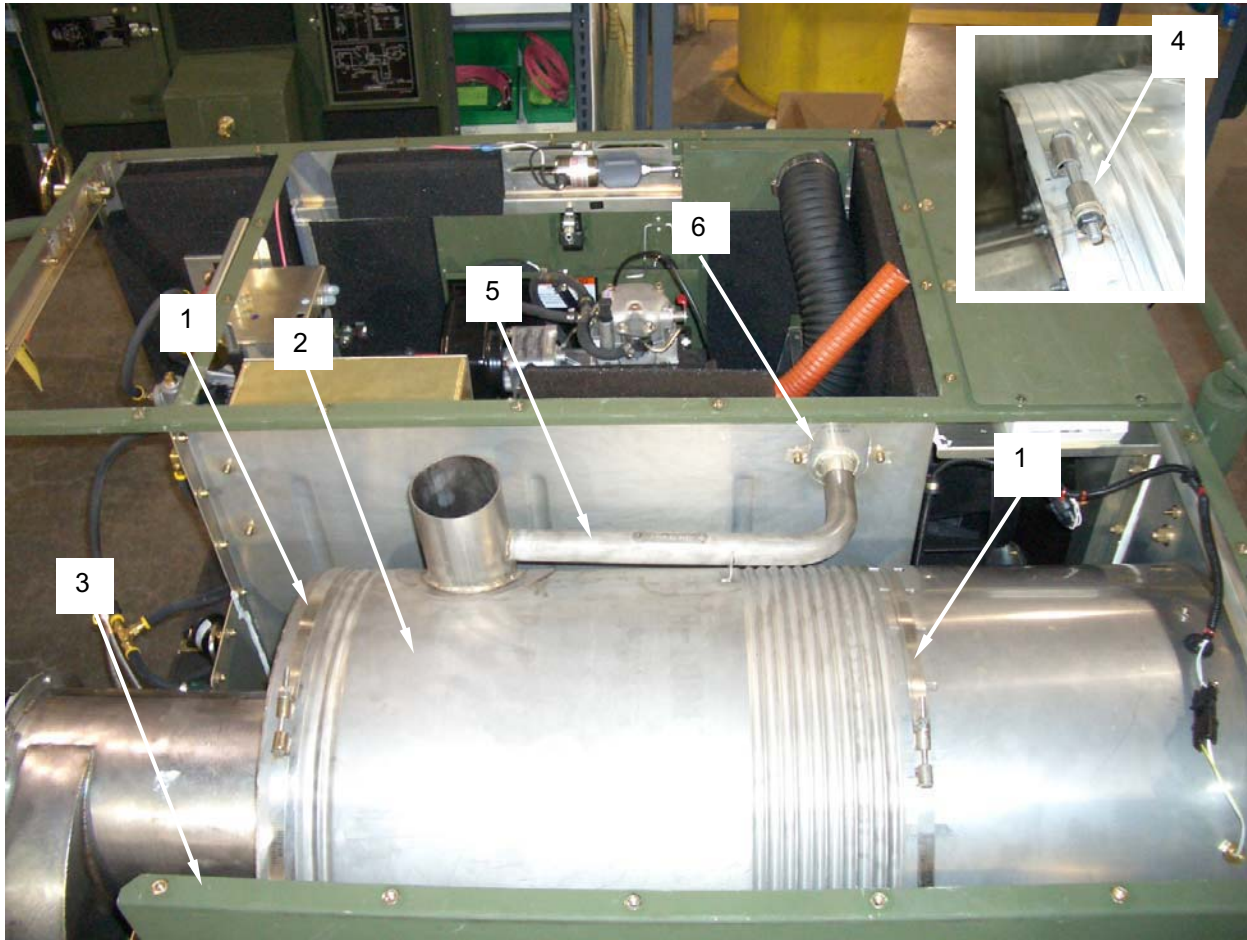

SERVICE – DRAIN CONDENSATION

1. Drain condensation from heat exchanger every 250 hours of operation by loosening the drain valve **(1)** located at the end of the heat exchanger to the left of the jack assembly.
2. Drain any condensation that may have accumulated.
3. Tighten drain valve **(1)** securely.

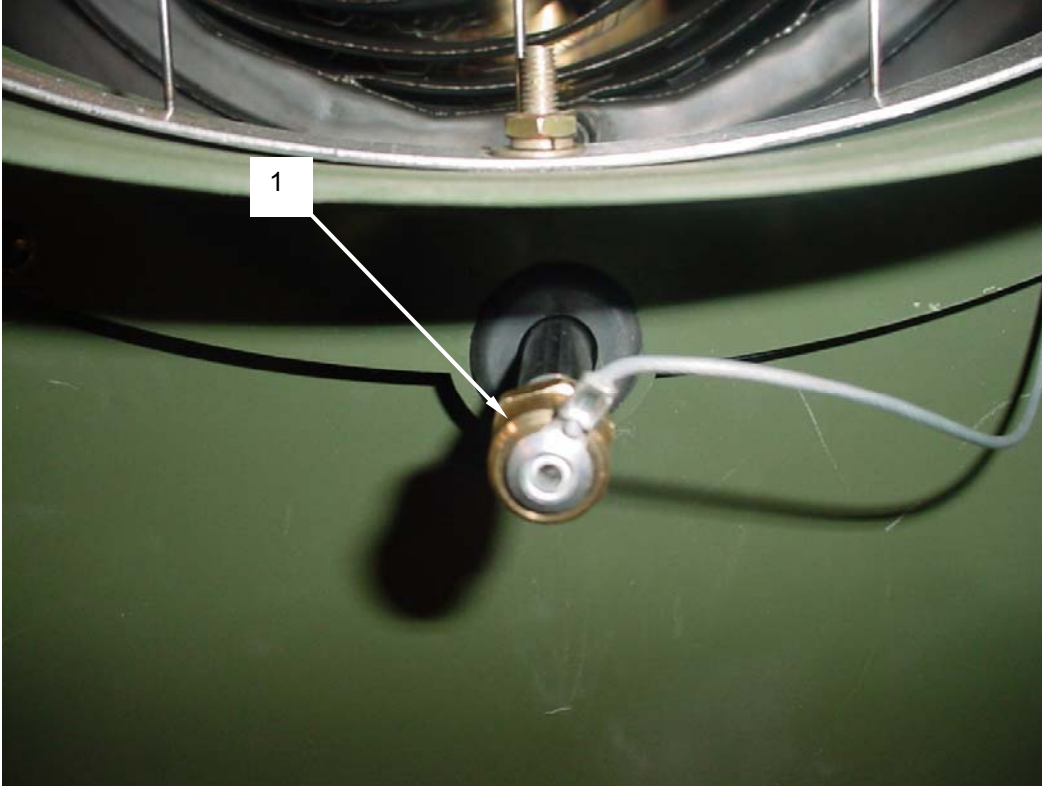

SERVICE - CLEAN THE HEAT EXCHANGER

1. Remove burner back plate as described in WP 0050 00.
2. Remove burner cone as described in WP 0051 00.
3. Vacuum large cone deposits from bottom of heat exchanger.
4. Use a long, thin brush to brush the inside surfaces of the heat exchanger.
5. Vacuum carbon brushed from heat exchanger surfaces that will fall to the bottom of the heat exchanger.
6. Install burner cone as described in WP 0051 00.
7. Install burner back plate as described in WP 0050 00.

NOTE

After cleaning heat exchanger it is not unusual to see a small amount of light smoke when unit is started. The smoke should clear within 30 minutes. If smoke is heavy and black after cleaning heat exchanger, shut unit off and troubleshoot for excessive fuel or low combustion airflow.

REPLACE**WARNING**

The heat exchanger weighs approximately 85 lbs (38.5 kg). A minimum of two personnel are required to lift the heat exchanger out of the heater cabinet. A mechanical lift using a strap positioned under the centerline of the heat exchanger is preferred to using manpower. Failure to lift the heat exchanger properly may result in serious injury.

1. Remove burner cover and burner nozzle and electrode assembly IAW WP 0050 00. Set assemblies aside.
2. Remove nuts, lock washers, and flat washers **(1)** on inlet of heat exchanger **(2)**.
3. Loosen clamp and remove diesel engine exhaust stack **(3)**.
4. Loosen and separate the two saddle clamps **(4)** that encircle the heat exchanger **(2)**.
5. Lift the heat exchanger from the heater with a minimum of 2 persons or with a mechanical lift rated for at least 85 lbs (38.5 kg).
6. Install a new heat exchanger **(2)** by lowering into position onto the saddles at the base of the heater.
7. Engage the two saddle clamps **(4)** around the heat exchanger **(2)** and tighten.
8. Install the diesel engine exhaust stack **(3)**.
9. Install flat washers, lockwashers, and nuts **(1)** on inlet of heat exchanger **(2)**.
10. Install top cover on heater.
11. Install burner cover and burner nozzle and electrode assembly IAW WP 0050 00.

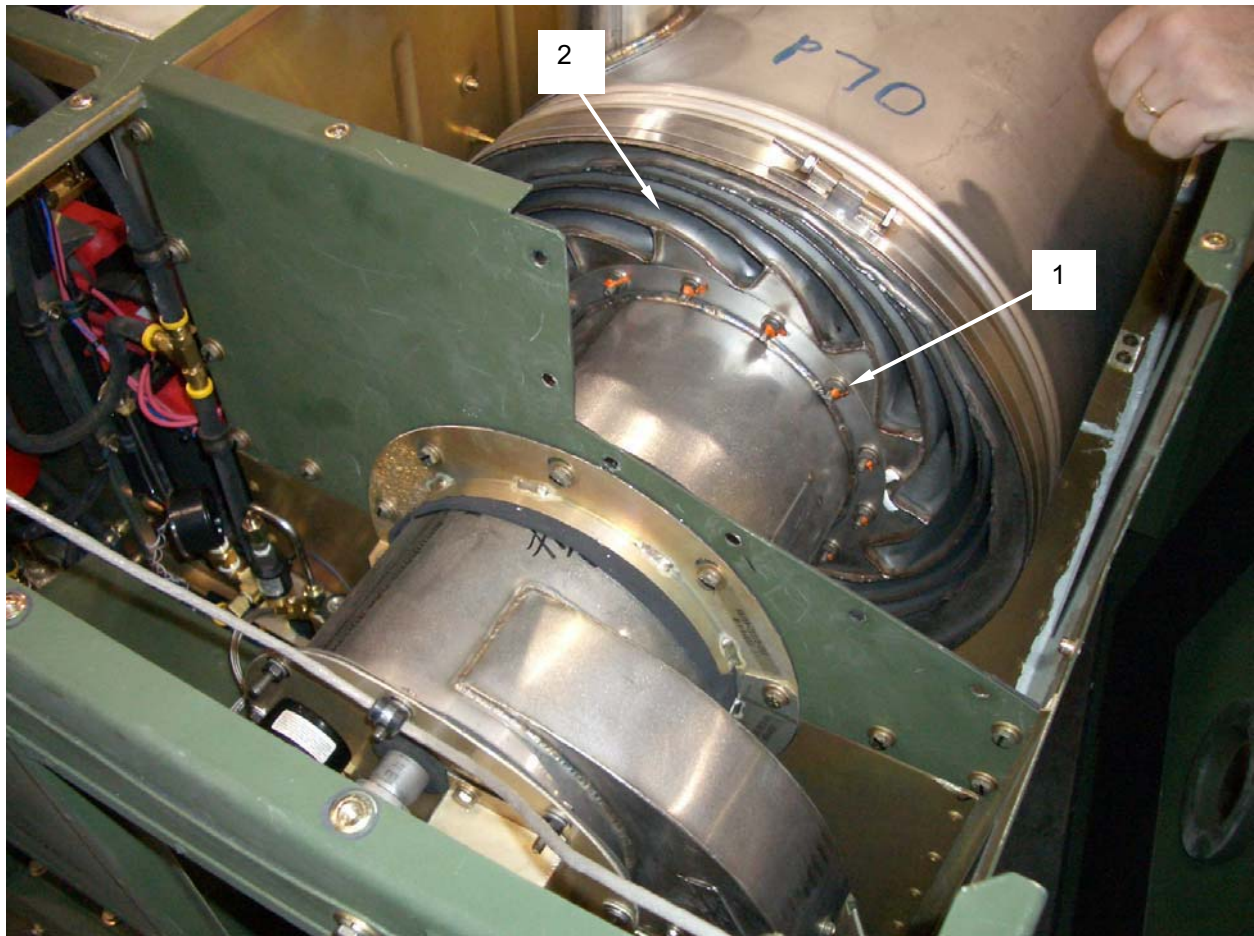

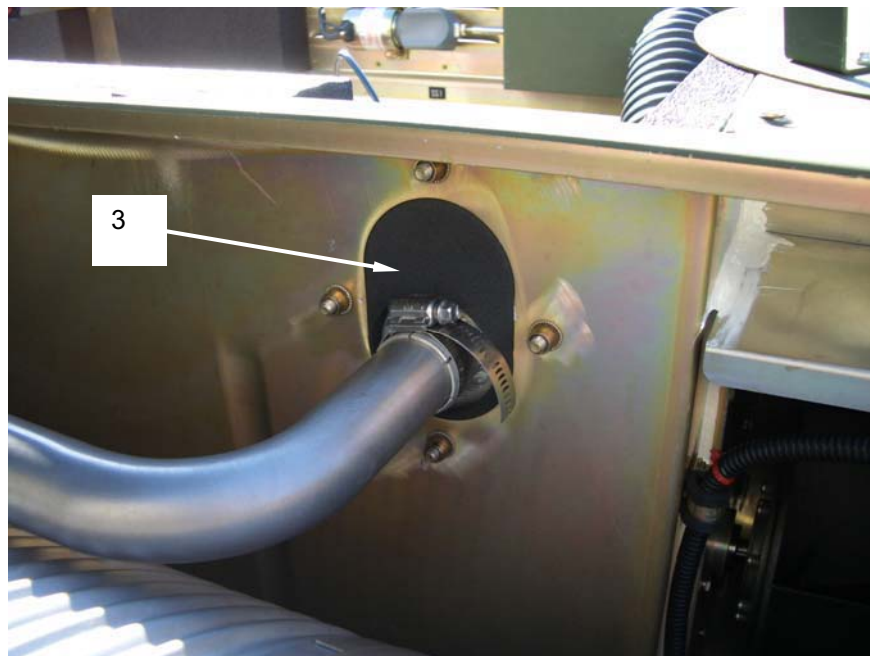

END OF WORK PACKAGE

FIELD (UNIT) MAINTENANCE
LARGE CAPACITY FIELD HEATER
NSN 4520-01-500-1534
OUTLET TEMPERATURE SENSOR
REMOVE, TEST, REPLACE

INITIAL SETUP:**Tools**

Tool Kit, General Mechanics (WP 0092 00, Item 2)

Personnel Required

MOS 63J or 52C

Materials/Parts

None required

Equipment ConditionHeater shut down and cool.
Main battery switch OFF and handle removed.

REMOVE

Remove three bolts (1) from the front edge of the heat exchanger top cover, along with four bolts (1) down the outside edge, and the two bolts (1) common to the fan inlet top, to gain access to the connector at the rear of the outlet temperature sensor.

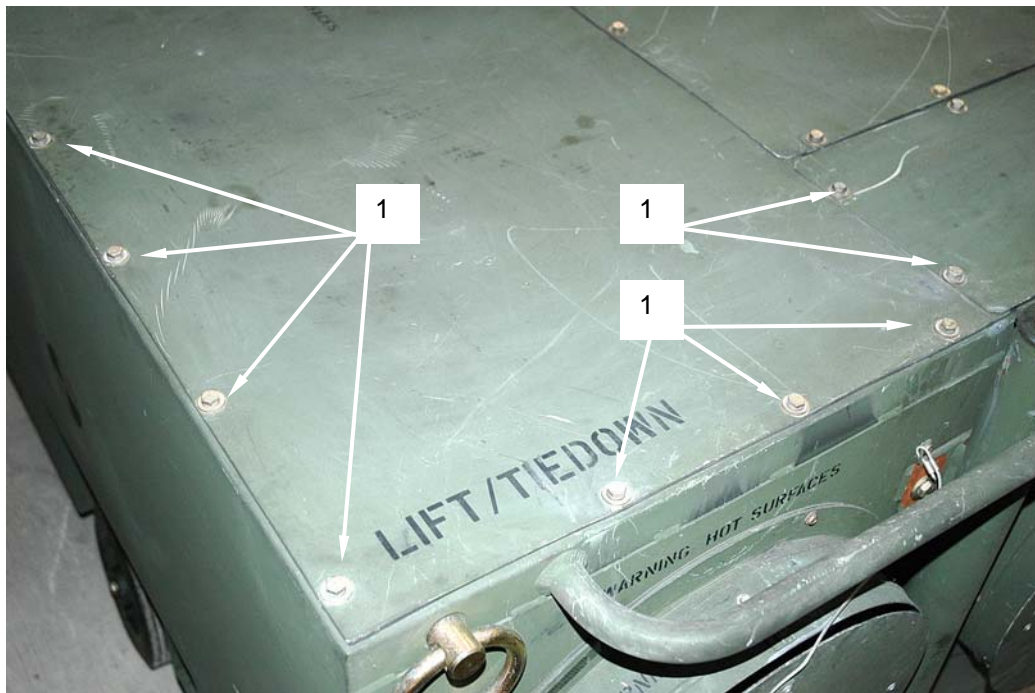

TEST

1. Disconnect the connector **(2)** attaching the outlet temperature sensor to the main wire harness by unclipping the two halves.
2. Using a multimeter, test for continuity across the outlet temperature sensor terminals. If a resistance reading between 75 and 120 ohms is not verified (i.e. open circuit), or 0 ohms (i.e. shorted circuit) replace the outlet temperature sensor as detailed in the next section.

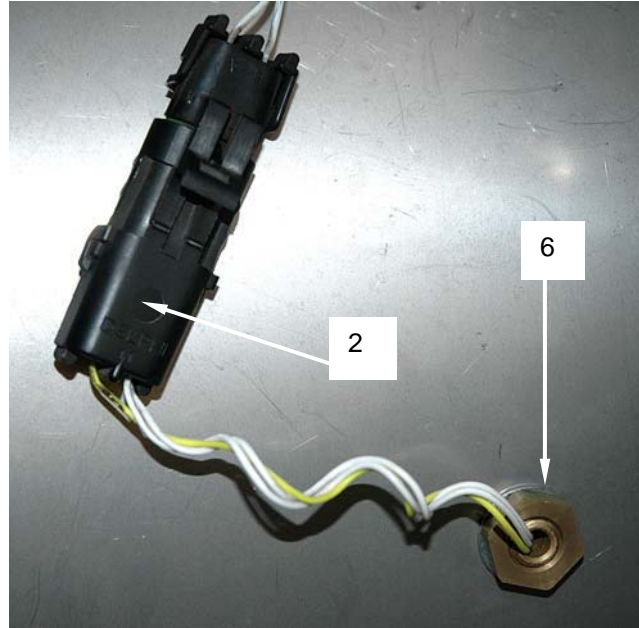
**REPLACE**

1. Remove the safety screen **(3)** by installing the two screws **(4)**, lock washers, and flat washers at the top and bottom and two nuts **(5)**, lock washers, and flat washers on the left and right sides.
2. Cut the white and yellow wires between the connector and the outlet temperature sensor and discard connector end.
3. Remove the nut **(6)** and lock washer mounting the elbow of the outlet temperature sensor to the heat exchanger extension tube and remove sensor **(7)**.
4. Install new outlet temperature sensor horizontally, and parallel to the face of the heat exchanger. Use the nut and lock washer previously removed to remount the sensor. Do not place pins into connector housing until the sensor is mounted.
5. Push wires into connector provided with temperature sensor and clip the rear of the connector shut after wires are seated.
6. Connect the two connector ends and bolt heat exchanger top back down.

7. Install the safety screen (3) by installing the two screws (4), lock washers, and flat washers at the top and bottom and two nuts (5), lock washers, and flat washers on the left and right sides.

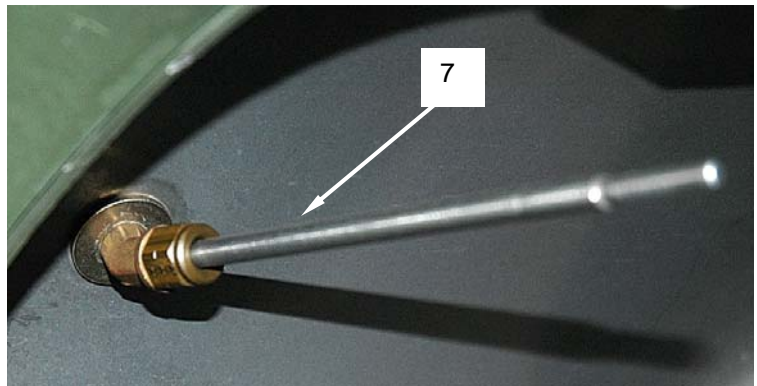
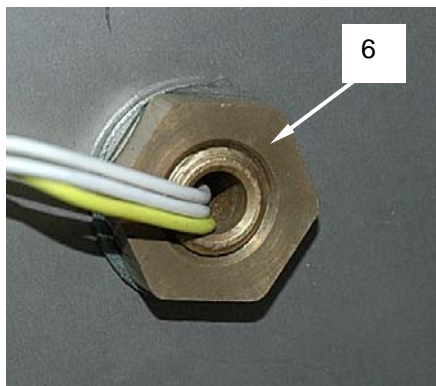
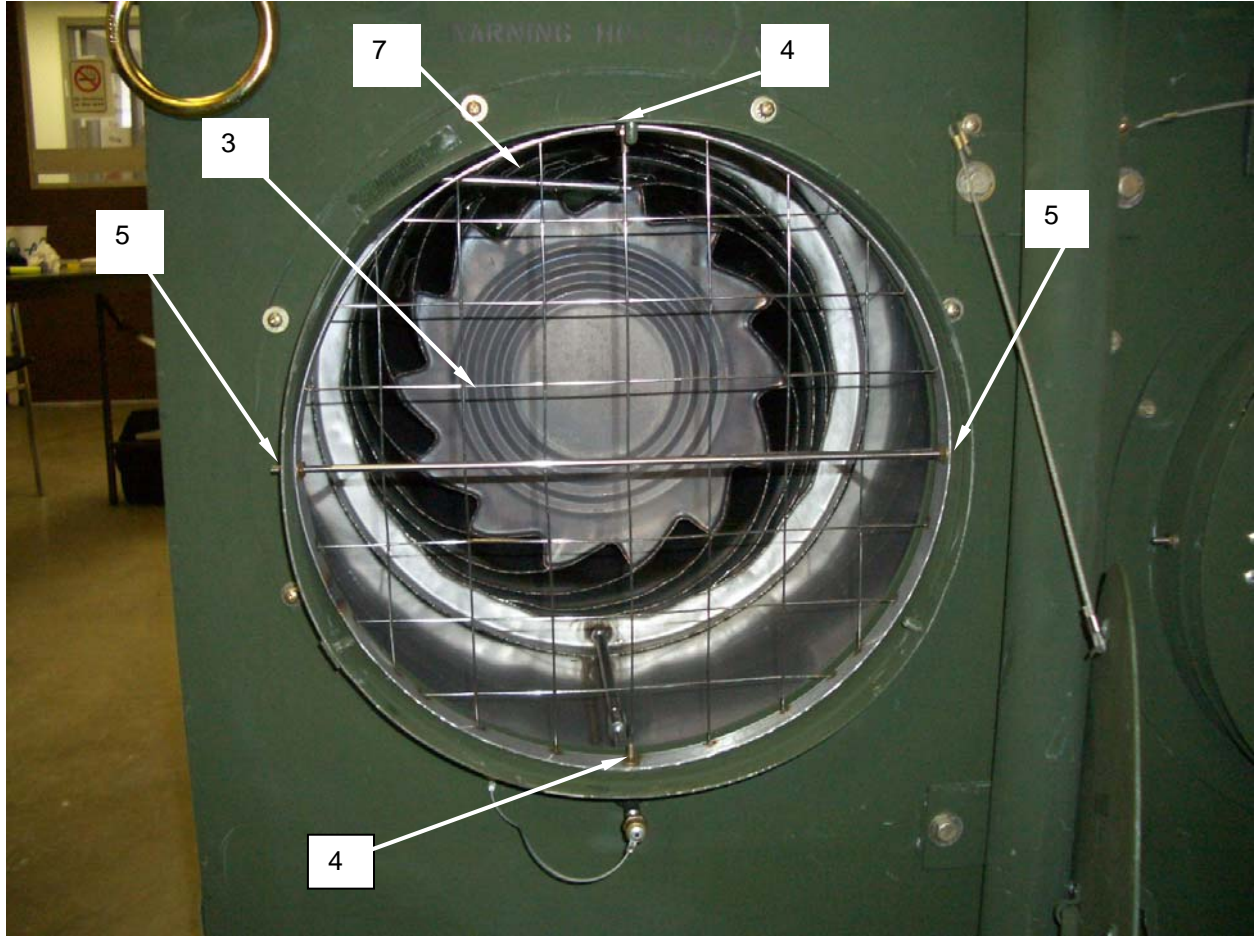

END OF WORK PACKAGE

 FIELD (UNIT) MAINTENANCE

LARGE CAPACITY FIELD HEATER (LCFH)

NSN 4520-01-500-1534

 WIRE HARNESS ASSEMBLIES
 INSPECT, REPAIR

INITIAL SETUP:

Tools

Tool Kit, General Mechanics (Item 2, WP 0092 00)

Personnel Required

MOS 63J or 52C

Materials/Parts

Tape, electrical (Item 6, WP 0119 00)
 Wrap, tie (Item 9, WP 0119 00)

Equipment Condition

Heater shut down and cool.
 Engine bay access door open.
 Main battery switch OFF and handle removed.

NOTE

There are numerous wiring harness assemblies and cables throughout the LCFH. The inspection and repair processes for all are identical. Photos shown are representative of all wire harnesses, connectors, and tie wraps throughout the heater.

INSPECT

1. Inspect the connectors **(1)** on the wire harness to ensure that all connectors are securely mated and locked together.
2. Inspect the wire **(2)** for any cuts or abrasions to the insulation that would expose bare wire. Repair any breaks or abrasions as detailed below.
3. Inspect the tie wraps **(3)** and ensure that none are broken or cut. Replace any tie wraps that are damaged.

REPAIR

1. Repair any cuts or abrasions on the wires **(2)** with electrical tape, wrapping each repaired area with at least two layers of tape.
2. Repair tie wraps **(3)** by removing any broken pieces and installing a new tie wrap.
3. Repair any broken or damaged terminal lugs **(4)** by replacing with new lug.

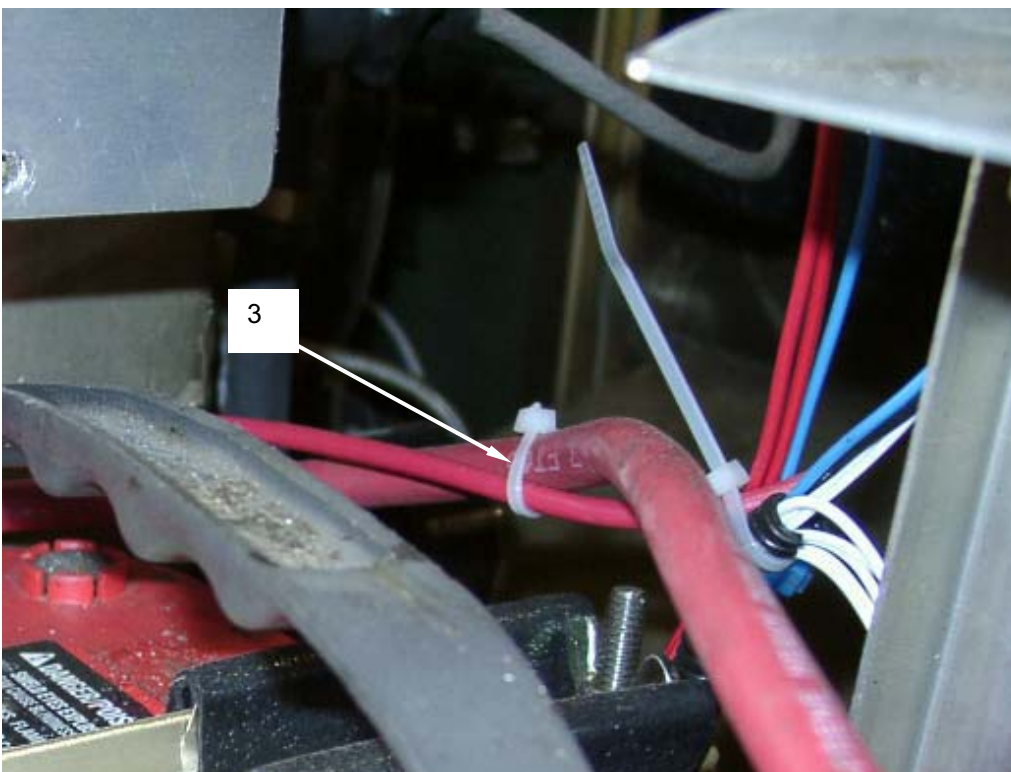
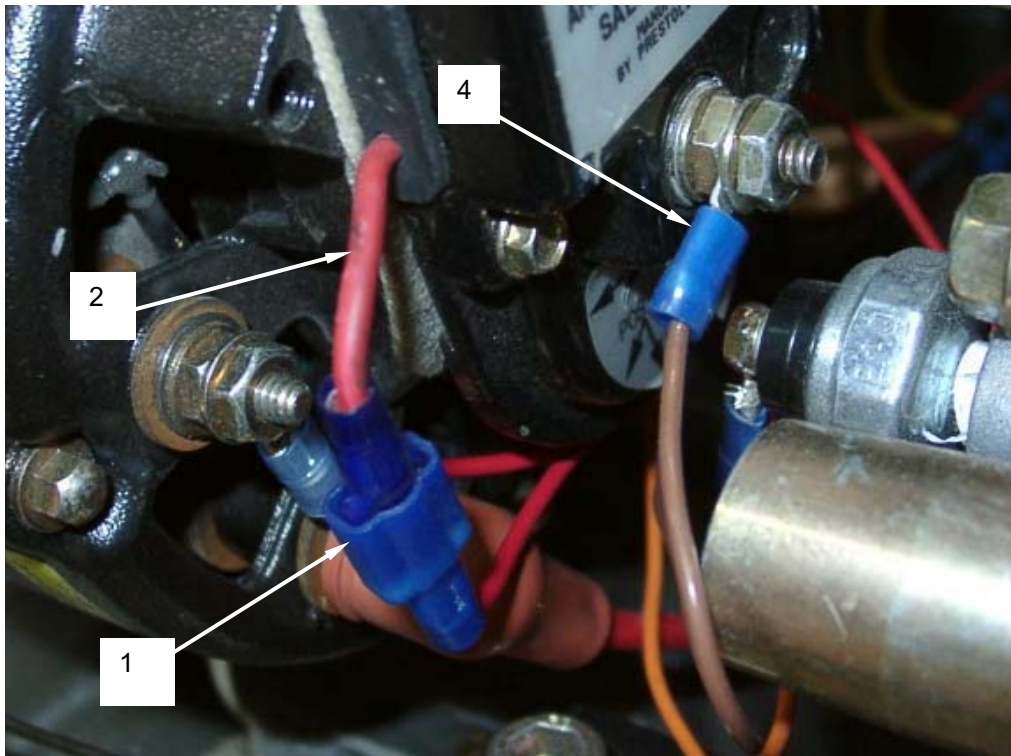

END OF WORK PACKAGE

FIELD (UNIT) MAINTENANCE

LARGE CAPACITY FIELD HEATER (LCFH)

NSN 4520-01-500-1534

BATTERY TERMINAL CONNECTOR
INSPECT, SERVICE, REPLACE

INITIAL SETUP:

Tools

Tool Kit, General Mechanics (Item 2, WP 0092 00)

Personnel Required

MOS 63J or 52C

Materials/Parts

Rag, wiping, clean (Item 4, WP 0119 00)

Equipment Condition

Heater shut down and cool.
Engine bay access door open.
Main battery switch OFF and handle removed.**WARNING**

Leather gloves and eye protection must be worn when performing maintenance involving batteries. Failure to do so could result in serious injury to eyes or hands.

**WARNING**

Disconnect the negative battery terminal on the battery closest the engine bay access door before performing maintenance involving the batteries. Failure to do so may result in shock or other serious injury.

INSPECT

Inspect the terminal connector **(1)** to ensure that there is no corrosion that would prevent a good electrical connection. Clean any corroded terminal connections as detailed in the section of this work package entitled SERVICE.

SERVICE

NOTE

Slide flexible protective covering off terminal before beginning service on battery terminal. Replace the covering when maintenance is complete.

1. To clean a corroded battery terminal connector **(1)**, loosen the nut **(2)** that secures the terminal connector to the battery terminal post **(3)**.
2. Remove the battery terminal connector **(1)** from the battery terminal post **(3)**. To make removal easier, it may be necessary to force the terminal open a bit using the blade of a flat blade screwdriver in the gap **(4)** between the arms of the terminal. Pry the terminal connector **(1)** off the battery terminal post **(3)**. If the terminal connector is damaged in the removal process, it should be replaced in accordance with the section of this work package entitled REPLACE.

SERVICE continued

3. Once the battery terminal connector has been removed from the battery terminal post (3), clean the battery terminal connector (1) and battery terminal post with a wire brush.
4. Install the battery terminal connector (1) on the battery terminal post (3) and secure the nut (2).

REPLACE

1. To replace a damaged terminal connector (1), remove the connector from the battery terminal post (3) as described in the SERVICE section above.
2. Cut the damaged connector from the battery cable (5). If the cable is damaged, replace the cable first.
3. Strip approximately 1/2 inch of insulation (6) from the end of the battery cable.
4. Loosen the bolt (7) securing the terminal connector clamp (8) and insert the stripped portion of the battery cable into the clamp.
5. Tighten the bolt (7) to firmly secure the battery cable (5) in the clamp (8).
6. Install the terminal connector (1) onto the battery terminal post (3) and secure with the nut (2).

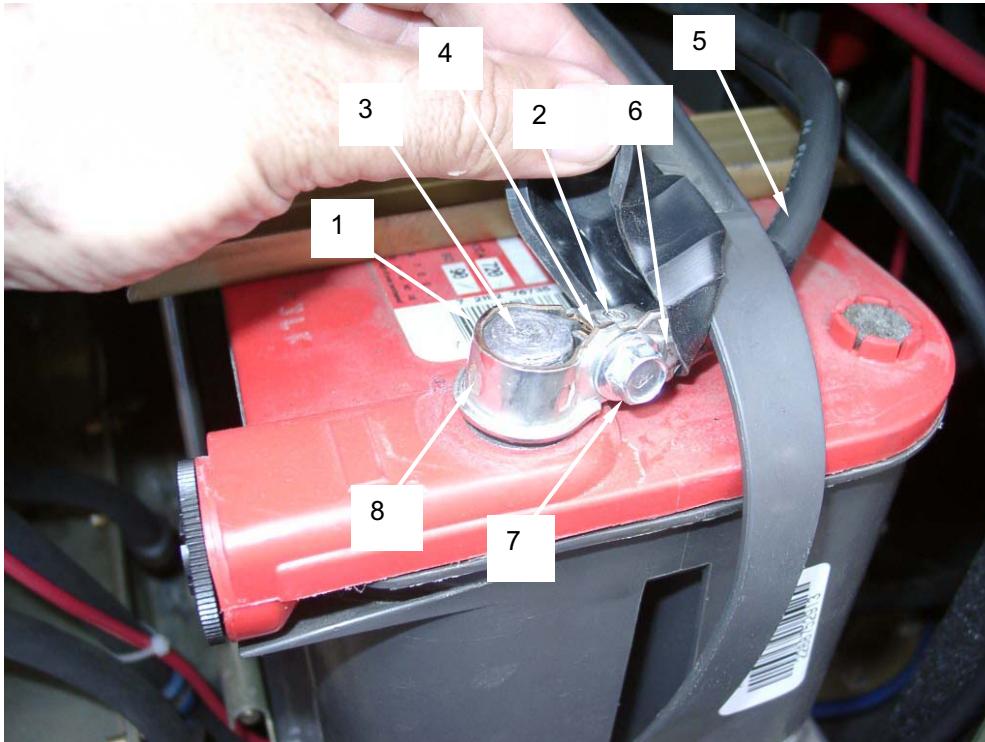
**END OF WORK PACKAGE**

FIELD (UNIT) MAINTENANCE

LARGE CAPACITY FIELD HEATER (LCFH)

NSN 4520-01-500-1534

BATTERY
INSPECT, TEST, REPLACE

INITIAL SETUP:

Tools

Tool Kit, General Mechanics (Item 2, WP 0092 00)

Test Set, Battery (Item 14, WP 0092 00)

Personnel Required

MOS 63J or 52C

Materials/Parts

Rag, cleaning (Item 4, WP 0119 00)

Equipment Condition

Heater shut down and cool.

Engine bay access door open.

Main battery switch OFF and handle removed.

**WARNING**

Leather gloves and eye protection must be worn when performing maintenance involving batteries. Failure to do so could result in serious injury to eyes or hands.

**WARNING**

Disconnect the negative battery terminal on the battery closest the engine bay access door before performing maintenance involving the batteries. Failure to do so may result in shock or other serious injury.

INSPECT

1. Inspect the batteries for any cracks or breaks that would allow battery fluid to leak from the batteries. Replace any damaged batteries.
2. Inspect the terminal connections **(1)** to ensure that there is no corrosion that would prevent a good electrical connection. Clean any corroded terminal connections as detailed in WP 0057 00.
3. Inspect the battery cables **(2)** going into the terminal connections to ensure that all conductors in the cable are unbroken and not corroded. Clean or trim cable as detailed in WP 0057 00, or replace battery cable in accordance with WP 0057 00.

TEST

Before replacing a battery, test using battery test set in accordance with the instructions included with the device.

REPLACE

1. To replace a defective or damaged battery, tag and mark the battery cables **(2)** of the battery being replaced. Mark the positive and negative cables as shown.
2. Loosen the nut **(3)** on each terminal of the battery being replaced and remove the terminal. To make removal easier, it may be necessary to force the terminal open a bit using the blade of a flat blade screwdriver in the gap **(4)** between the arms of the terminal. Pry the terminal connector **(1)** off the battery terminal **(5)**. If the terminal connector is damaged in the removal process, it should be replaced in accordance with WP 0057 00.
3. Remove the wingnuts **(6)** and lockwashers **(7)** that secure the battery T-bar **(8)** and set aside.
4. Remove the battery holddown bracket **(9)** that extends over the top of the battery and set aside.
5. Take note of the position of the battery being replaced. The new battery must be installed in the same position. The negative side (-) **(10)** of both batteries must face the engine bay access door side of the heater. The positive side (+) **(11)** of both batteries must face the heat exchanger side of the heater.
6. Remove the battery from the battery tray and discard in accordance with unit SOP and local environmental regulations.
7. Install a new battery in the same position as the one removed earlier. Refer to the previous step to ensure the negative and positive sides of the battery are positioned properly.
8. Install the battery holddown bracket **(9)** set aside earlier that extends over the top of the battery.
9. Install the wingnuts **(6)** and lockwashers **(7)** that secure the battery T-bar **(8)**.
10. Install the terminal connector on the appropriate battery terminal as tagged and marked earlier. Tighten the bolt **(3)** on each terminal of the battery securely.
11. Install the battery master switch handle **(12)**. Place battery master switch in the ON position.

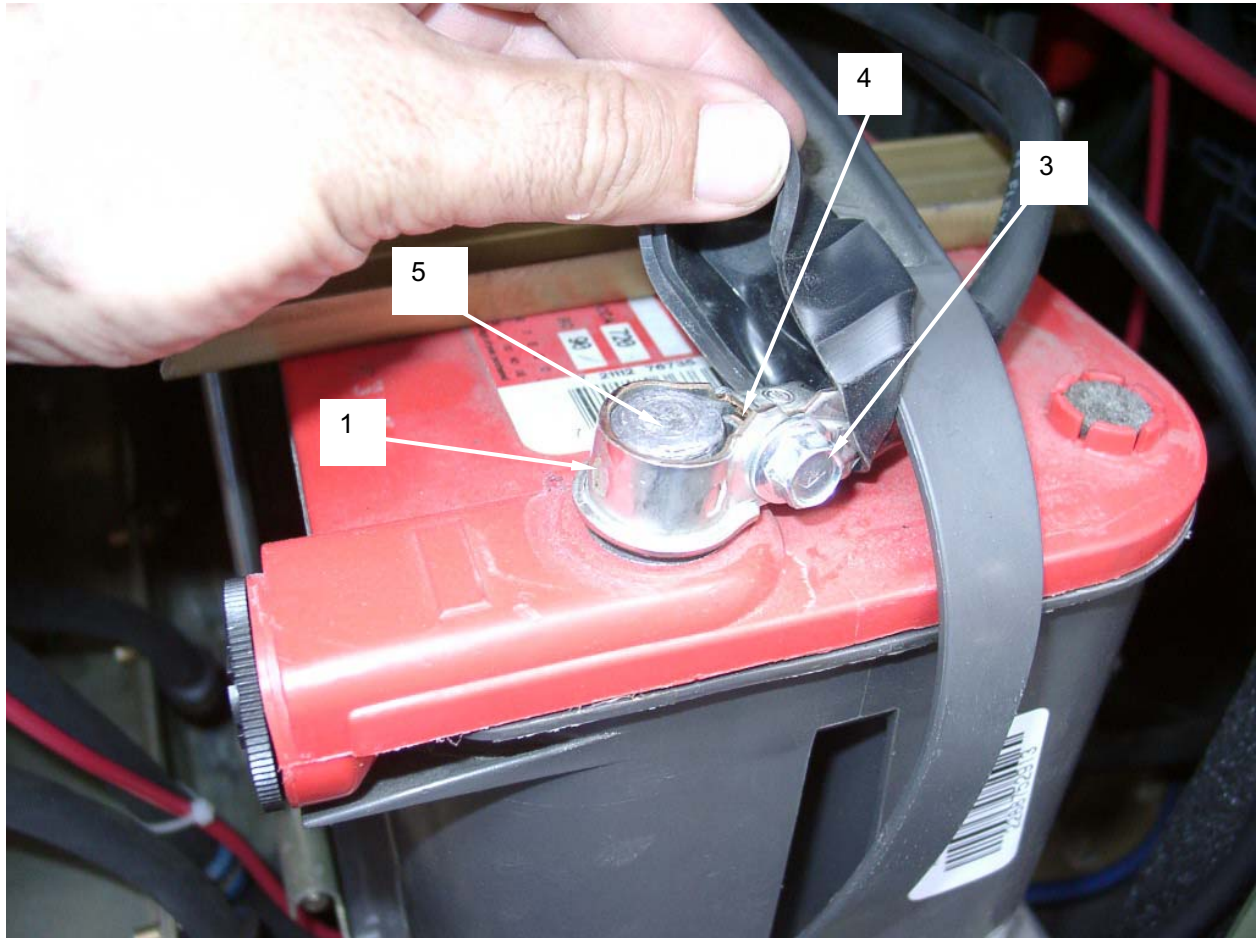

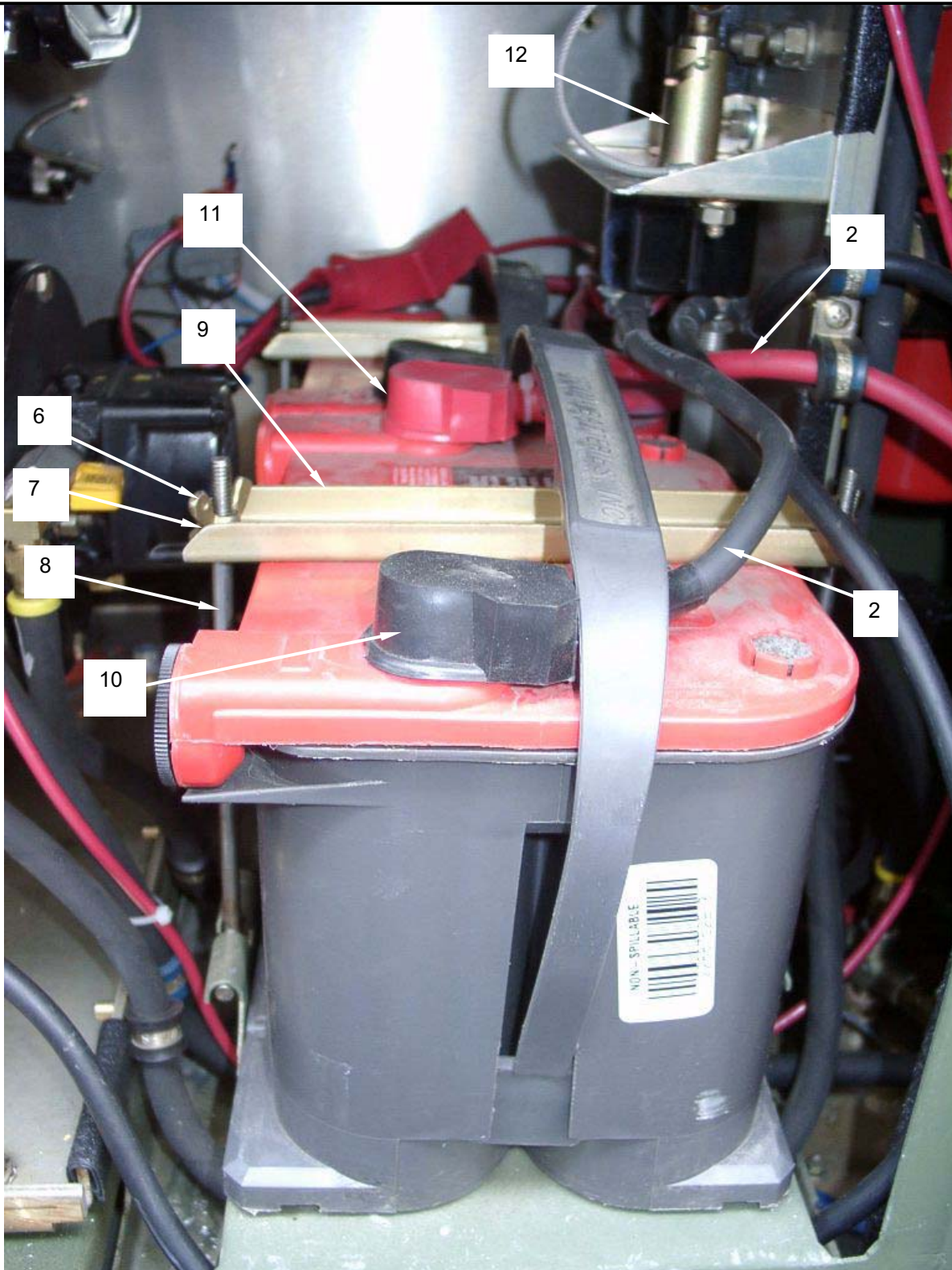

END OF WORK PACKAGE

FIELD (UNIT) MAINTENANCE

LARGE CAPACITY FIELD HEATER (LCFH)

NSN 4520-01-500-1534

BATTERY T-BAR AND HOLD DOWN PLATE ASSEMBLY
INSPECT, REPLACE**INITIAL SETUP:****Tools**Tool Kit, General Mechanics (Item 2, WP 0092
00)**Personnel Required**

MOS 63J or 52C

Materials/Parts

None required

Equipment ConditionHeater shut down and cool.
Engine bay access door open.
Main battery switch OFF and handle removed.**INSPECT**

Inspect the battery T-bar assemblies **(1)** and hold down plate **(2)** to ensure that they are not bent, corroded, or otherwise damaged in such a way that it would prevent the assemblies from securing the batteries to the battery mounting tray. Replace if T-bar or plate hold down assemblies are damaged.

REPLACE

1. To replace the battery T-bar assemblies **(1)** and hold down plate **(2)** hold down assembly, loosen and remove the wing nut **(3)**, lock washer **(4)**, and flat washer **(5)** on both sides of the battery **(6)**.
2. Slide the battery hold down plate **(2)** off the threaded ends of the T-bar assemblies **(1)**.
3. Remove both T-bar assemblies **(1)** by disengaging from the lower lip **(7)** of the battery mounting tray **(8)**.
4. Install two new T-bar assemblies **(1)** by engaging in the lower lip **(7)** of the battery mounting tray **(8)**.
5. Install the battery hold down plate **(2)** over the threaded ends of the two T-bar assemblies **(1)**.
6. Install the flat washer **(5)** , lock washer **(4)**, and wing nut **(3)** on both T-bar assemblies **(1)** and tighten securely.

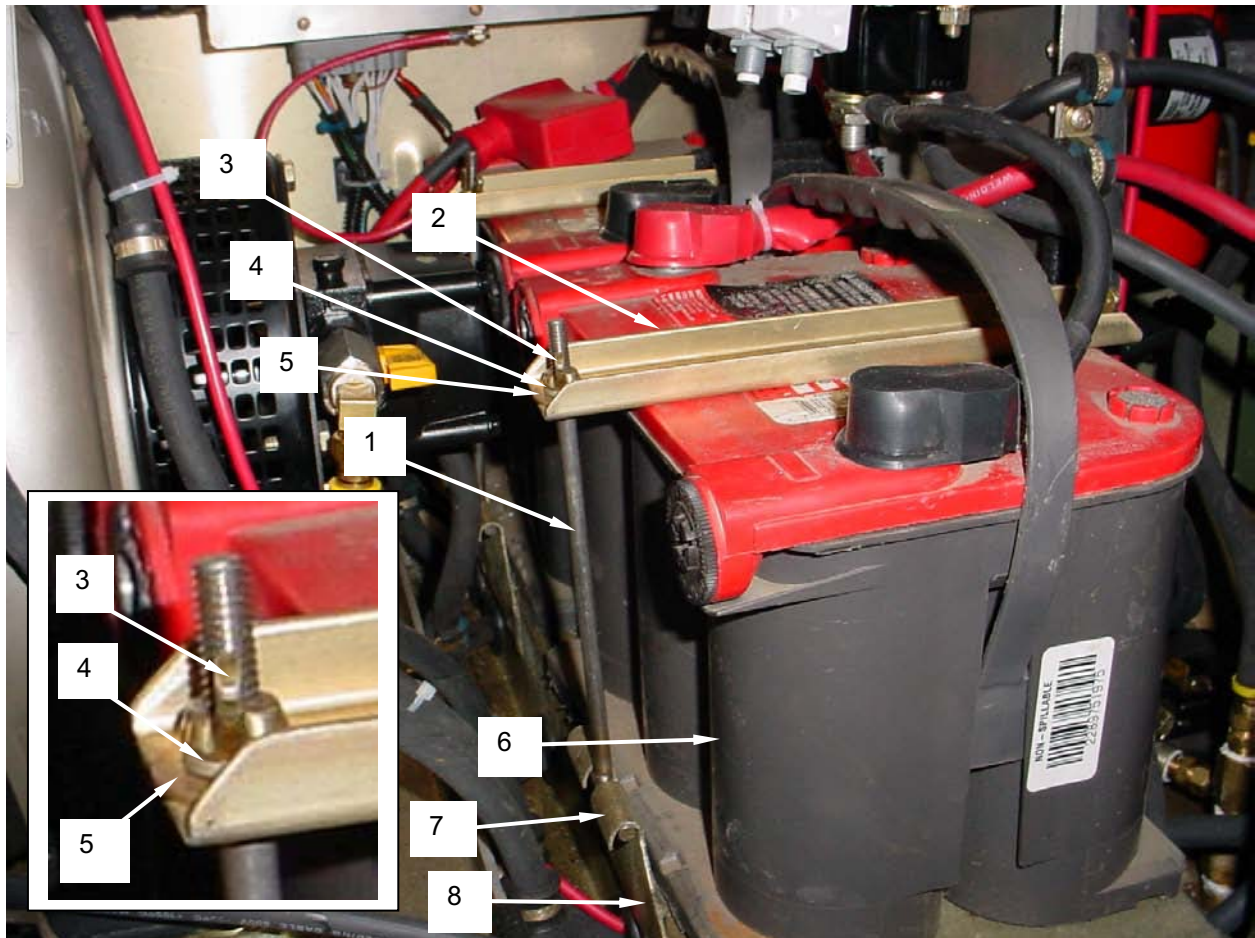

END OF WORK PACKAGE

FIELD (UNIT) MAINTENANCE**LARGE CAPACITY FIELD HEATER**

NSN 4520-01-500-1534

**SLAVE RECEPTACLE
REMOVE, INSPECT, INSTALL**

INITIAL SETUP:**Tools**

Tool Kit, General Mechanics (Item 2, WP 0092 00)

Personnel Required

MOS 63J or 52C

Materials/Parts

Tags, marking (Item 5, WP 0119 00)

Equipment ConditionHeater shutdown and cool
Main battery power switch OFF and handle removed

**WARNING**

Be sure to shutdown the heater and allow to cool before servicing. Failure to allow the heater to cool completely may result in severe burns or other injury.



Be sure to place the main battery power switch to the OFF position before removing the slave receptacle. Failure to do so may result electrical shock and/or damage to the equipment.

REMOVE

1. Unlock engine bay access door **(1)** and open door to gain access to slave receptacle **(2)**.
2. Remove outer protective cap **(3)** to gain access to slave receptacle mounting screws **(4)**.
3. Slide flexible protective covering **(5)** off wire connections on rear of slave receptacle to gain access to wire connection bolts.
4. Tag and disconnect electrical wiring **(6)** from the rear of slave receptacle **(2)** by removing hex head bolt **(7)** and washer **(8)**.
5. Remove slave receptacle **(2)** and attached outer protective cap **(3)** from heater cabinet by removing screws **(4)**, washers **(9)**, and nuts **(10)**.

INSPECT

1. Inspect receptacle for corrosion, evidence of electrical short, and obvious damage. Check terminal connectors for damage.
2. Inspect electrical wiring for cuts, crimps, bare wire, or other damage. Ensure terminal lugs are securely attached.

3. Remove and replace any component that is damaged to the extent that it will effect the safe operation of the heater.

INSTALL

1. Mate slave receptacle (2) and attached outer protective cap (3) to heater cabinet. Secure using screws (4), washers (9), and nuts (10).
2. Connect electrical wiring as tagged earlier to rear of slave receptacle (2) using hex head bolt (7) and washer (8).
3. Slide flexible protective covering (5) up and onto wire connections on rear of slave receptacle to cover wire connection bolts.
4. Install main battery power switch handle (11) and rotate to the ON position.
5. Close engine bay access door (1) and lock in place using latches.



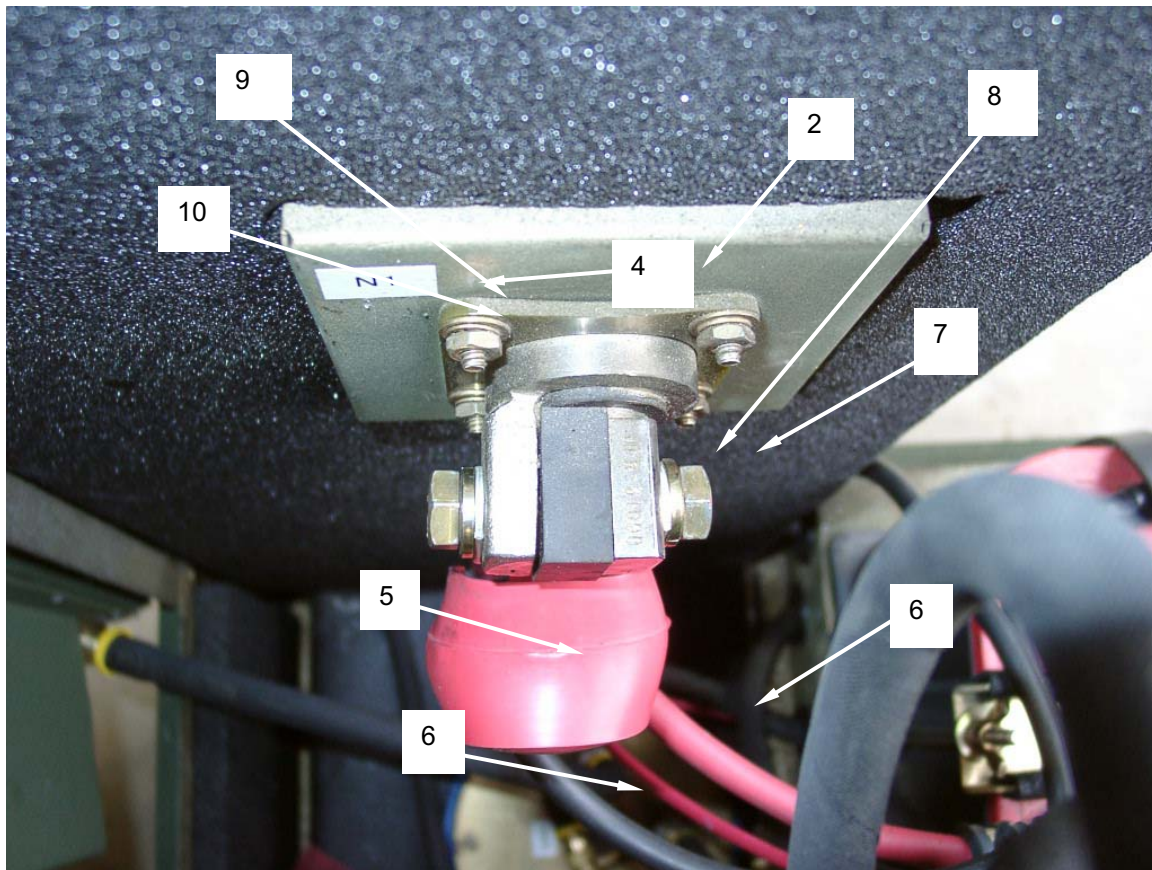
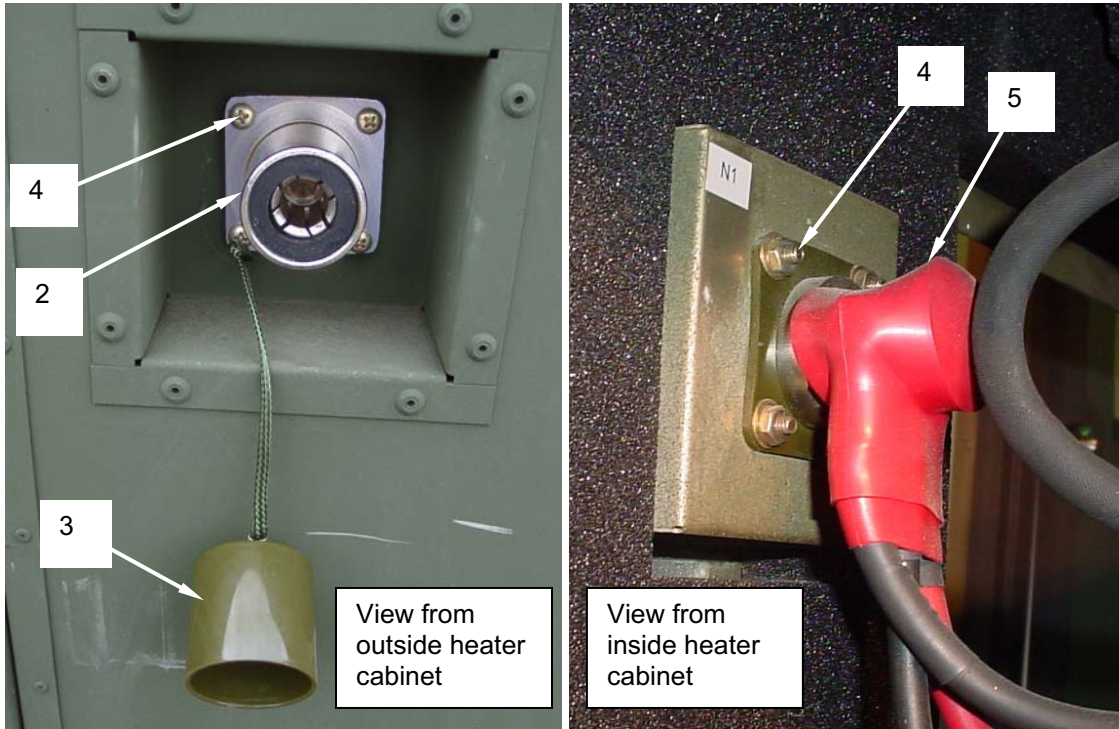

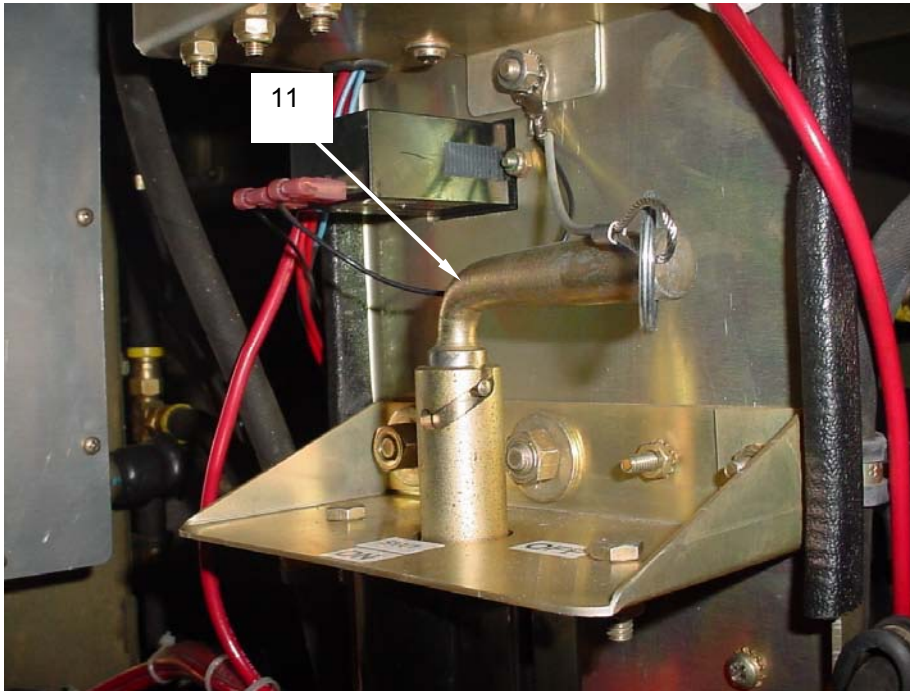

END OF WORK PACKAGE

FIELD (UNIT) MAINTENANCE**LARGE CAPACITY FIELD HEATER (LCFH)**

NSN 4520-01-500-1534

**OPERATOR CONTROL BOX CABLE ASSEMBLY
INSPECT, TEST, REPLACE**

INITIAL SETUP:**Tools**Tool Kit, General Mechanics (Item 2, WP 0092
00)**Personnel Required**

MOS 63J or 52C

Materials/Parts

None required

Equipment ConditionHeater shut down and cool.
Engine bay access door open.
Main battery switch OFF and handle removed.
Burner access door open.
Fuel access door open.

INSPECT

Inspect the operator control box cable connector **(1)** for cracks, dents to the outer collar, dirt in the contacts, or any other damage that would prevent the connector **(1)** from making a good electrical connection with the operator control box connector **(2)**.

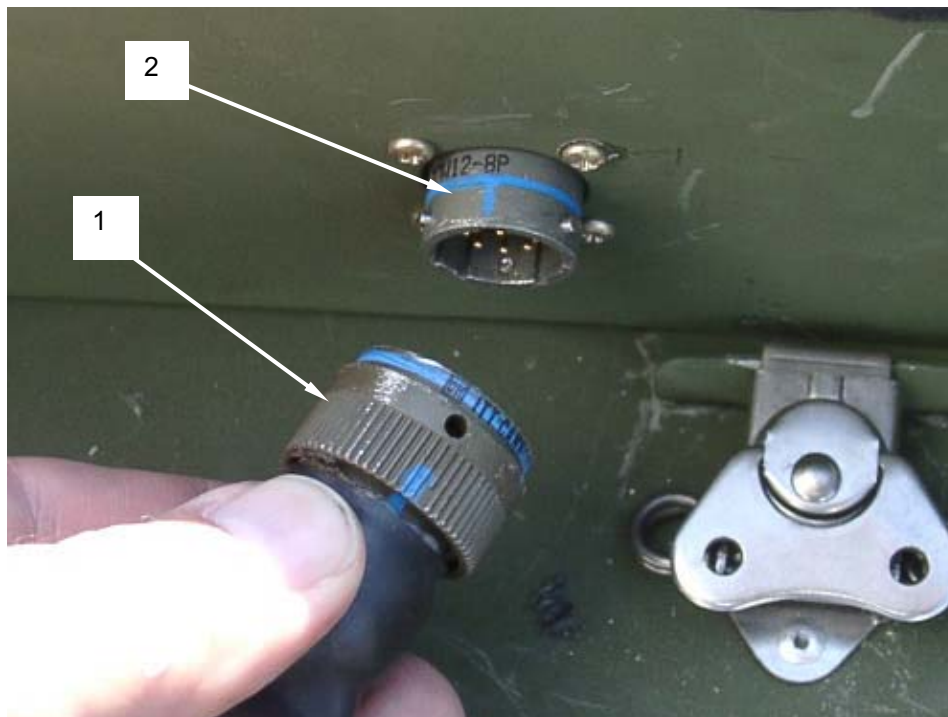

TEST

1. Using a multimeter, perform a continuity check from pin A at one end of cable to pin A at opposite end of cable. Repeat for all pins. Ensure that there is continuity through the cable.
2. Using a multimeter, perform a short circuit test across all terminals of the connector. For example, test from pin A to pin B, A to C, A to D, etc. Followed by B to A, B to C, B to D, etc. There should not be shorts across any of the pins. If shorts exist, replace the operator control box cable assembly.
3. If there is a lack of continuity through the cable or shorts within either of the connectors, replace the operator control box cable assembly.

**REPLACE**

1. Disconnect the operator control box cable assembly connector (1) from the operator control box connector (2).
2. Remove the nuts or bolts (3) and lock washers (4) that secure the two clamps (5) that secure the operator box cable assembly (6) inside the heater.
3. Remove operator control box cable assembly (6) from the clamps (5) and set the clamps, screws, and lock washers aside.

REPLACE continued

4. Disconnect the operator control box cable assembly (6) from the connector (7) located at the lower right corner of the main control box (8).
5. Install a new operator control box cable assembly (6) by connecting one of the cable connectors (9) to the main control box connector (7). Tighten securely.
6. Slip clamps (5) over the cable and secure to the two locations in the heater with screws (3) and lock washers (4). Tighten securely.
7. Slide the remaining cable connector (2) through the hole (10) near the operator control box (11).
8. Secure the operator control box cable assembly connector (1) to the operator control box connector (2).

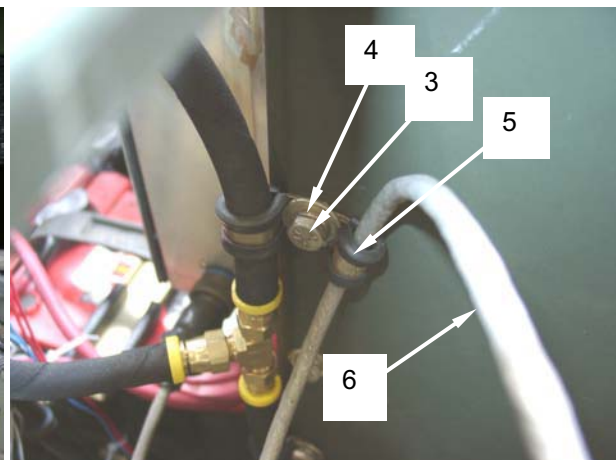
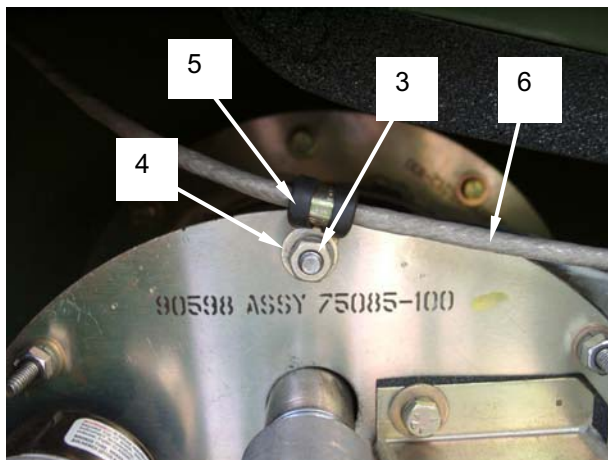
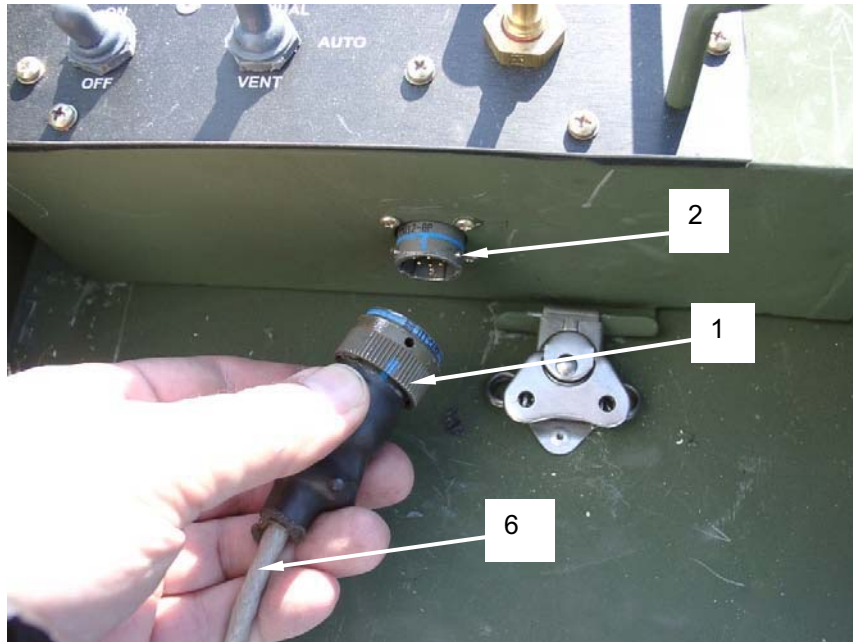

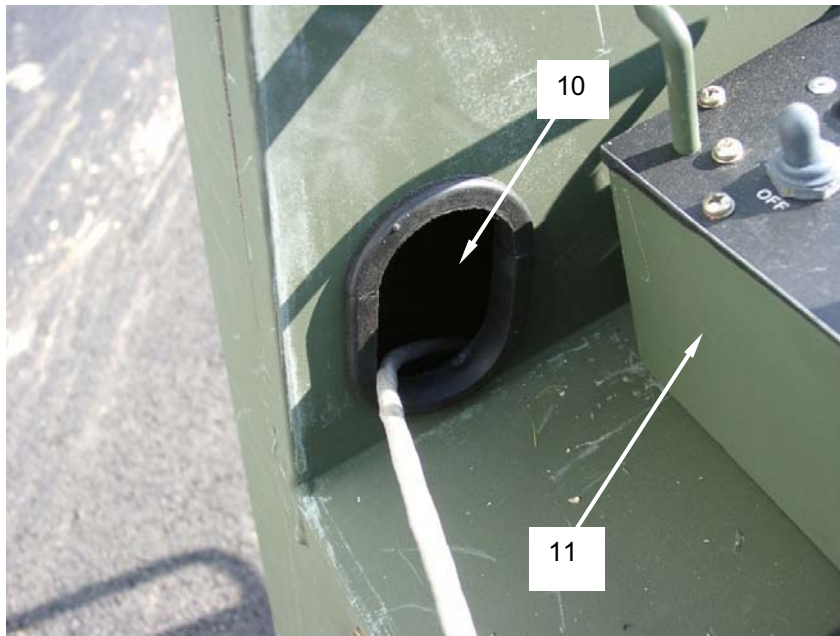
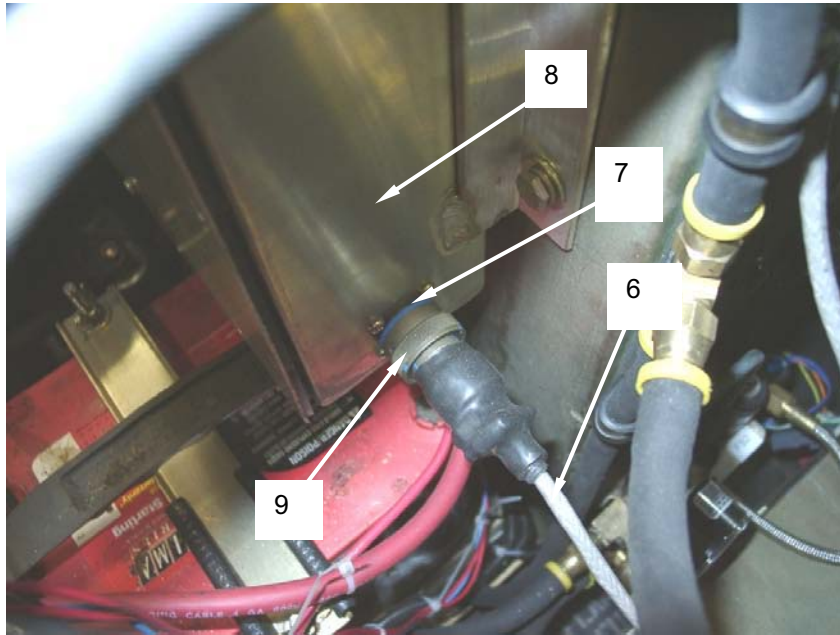

END OF WORK PACKAGE

 FIELD (UNIT) MAINTENANCE

LARGE CAPACITY FIELD HEATER (LCFH)

NSN 4520-01-500-1534

 RELAY BOX ASSEMBLY
 REPAIR

INITIAL SETUP:

Tools

Tool Kit, General Mechanics (Item 2, WP 0092
00)

Personnel Required

MOS 63J or 52C

Materials/Parts

Tags, marking (Item 5, WP 0119 00)

Equipment Condition

Heater shut down and cool.
Main battery switch OFF and handle removed.
Engine bay access door open.
Remove engine bay top cover.

REPAIR

1. Remove the lower nut **(3)**, lock washer **(4)**, and flat washer **(5)**.
2. Remove the upper nut **(6)**, lock washer **(7)**, and flat washer **(8)**.
3. Remove the relay box assembly **(2)**.
4. Tag all wires inside relay box assembly.
5. Disconnect wires to defective relay.
6. Remove screw and nut that secures defective relay.
7. Remove defective relay.
8. Install a new relay in the relay box assembly **(2)**.
9. Secure new relay with screw and nut removed earlier.
10. Connect wires to new relay.
11. Remove all tags.
12. Align the top and bottom holes of relay box assembly **(2)** over the studs **(9)** protruding from the fuel access panel.
13. Install the upper flat washer **(8)**, lock washer **(7)**, and nut **(6)**. Tighten securely.
14. Install the lower flat washer **(5)**, lock washer **(4)**, and nut **(3)**. Tighten securely.

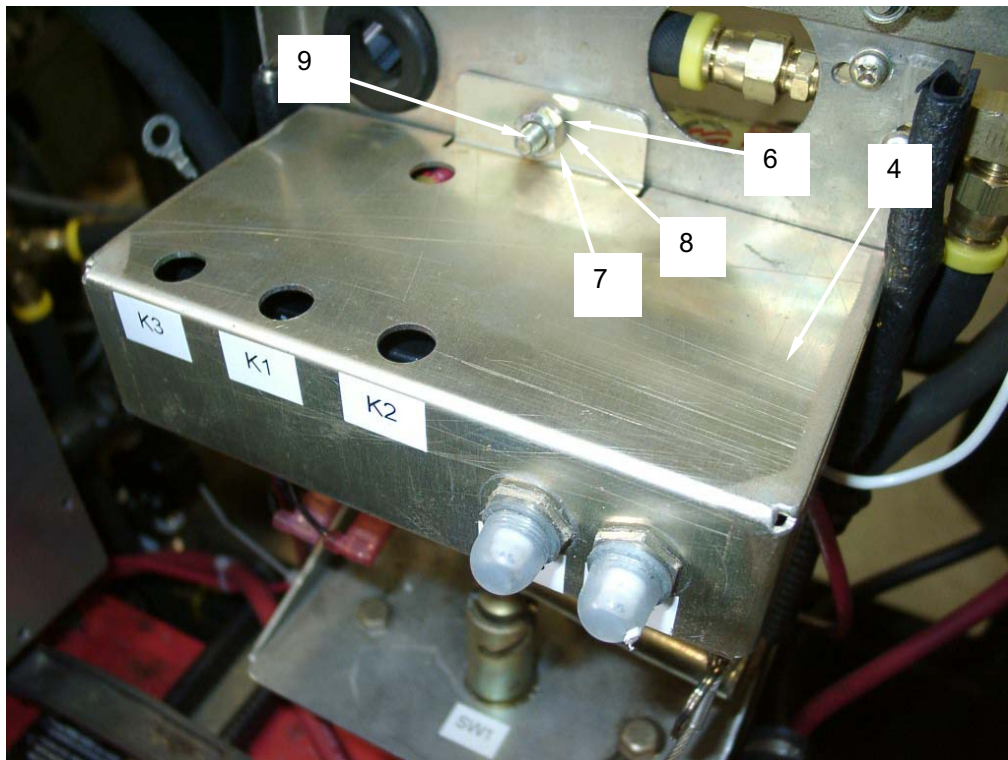
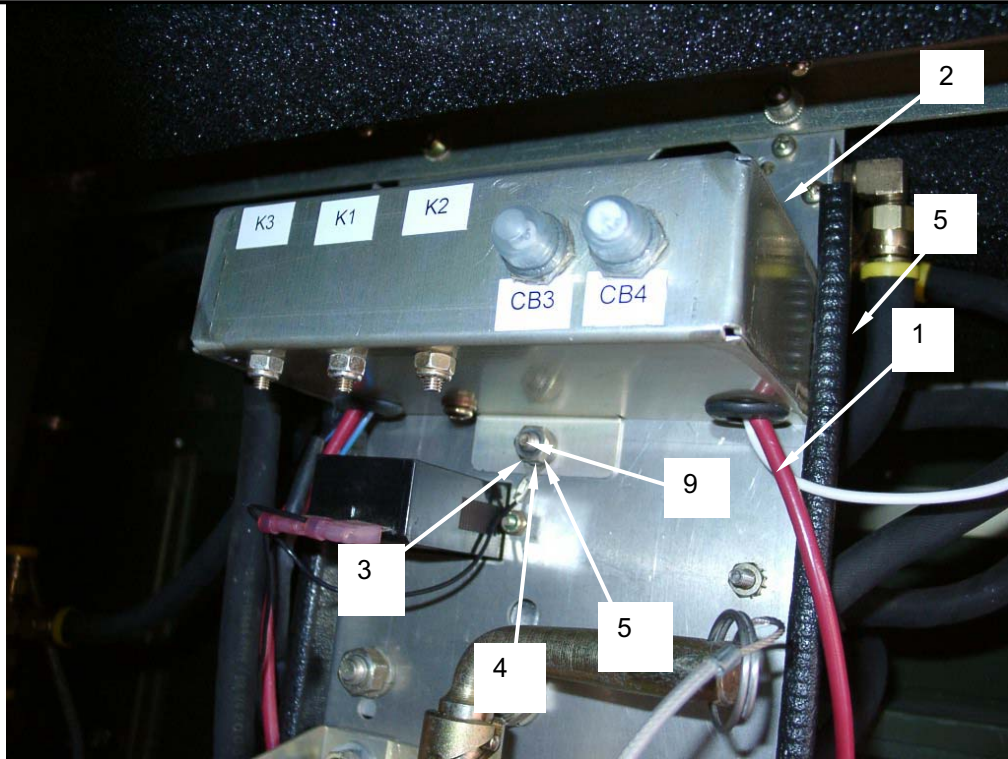

END OF WORK PACKAGE

FIELD (UNIT) MAINTENANCE

LARGE CAPACITY FIELD HEATER (LCFH)

NSN 4520-01-500-1534

MAIN PRINTED CIRCUIT BOARD BOX
REPLACE**INITIAL SETUP:****Tools**

Tool Kit, General Mechanics (Item 2, WP 0092 00)

Personnel Required

MOS 63J or 52C

Materials/Parts

Tags, marking (Item 5, WP 0119 00)

Equipment ConditionHeater shut down and cool.
Engine bay access door open.
Main battery switch OFF and handle removed.**REPLACE**

1. Tag the two cables **(1, 2)**, two wire harnesses **(3, 4)**, and air tube **(5)** that connect to the main printed circuit board box **(6)**.
2. Remove the main wire harness connector **(3)** by first removing the hex head screw **(9)** that secures the two halves of the connector.
3. Remove remaining harness connector **(4)**, two cables **(1, 2)**, and air tube **(5)** from sides and bottom of main printed circuit board box **(6)**.
4. Remove the four bolts and lockwashers **(7)** that secure the main printed circuit board box **(6)** to the main cabinet **(8)**.
5. Remove the main printed circuit board box **(6)** from the cabinet **(8)**.
6. Install a new main printed circuit board box **(6)** in position in the cabinet **(8)** and align the four holes on the box with those on the cabinet. Secure with four bolts and lockwashers **(7)**. Tighten securely.
7. Install the main wire harness connector **(3)** by installing the hex head screw **(9)** that secures the two halves of the connector.
8. Install the two cables **(1,2)**, remaining harness connector **(4)**, and air tube **(5)** that connect to the sides and bottom of the main printed circuit board box **(6)** as tagged earlier.

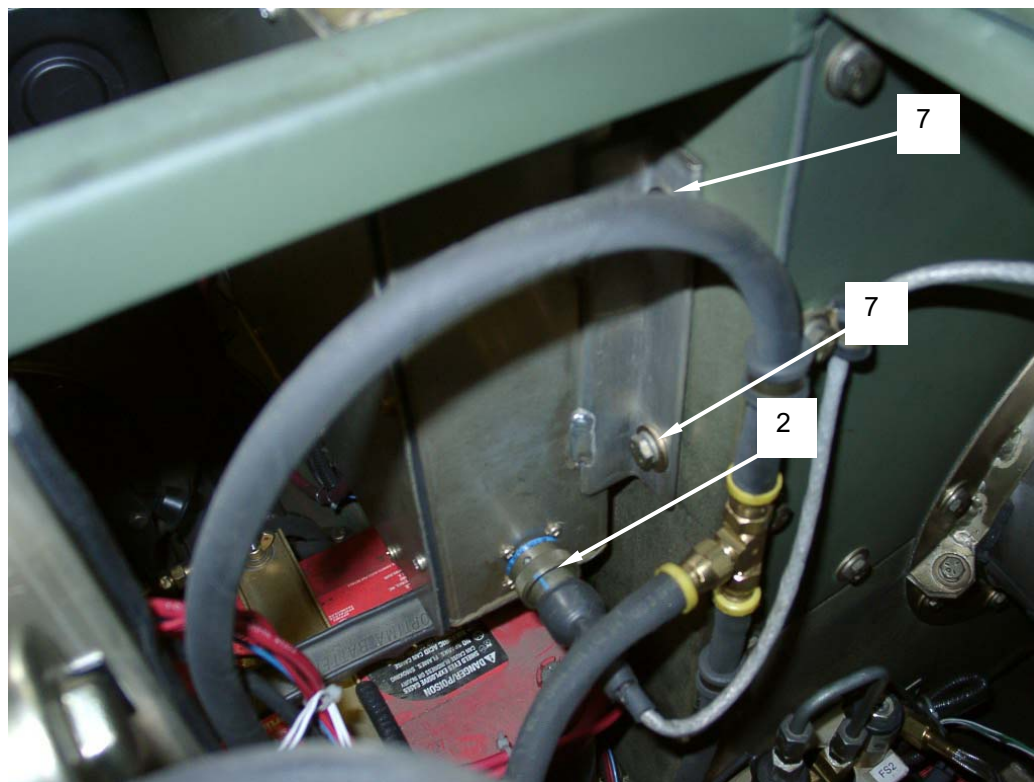
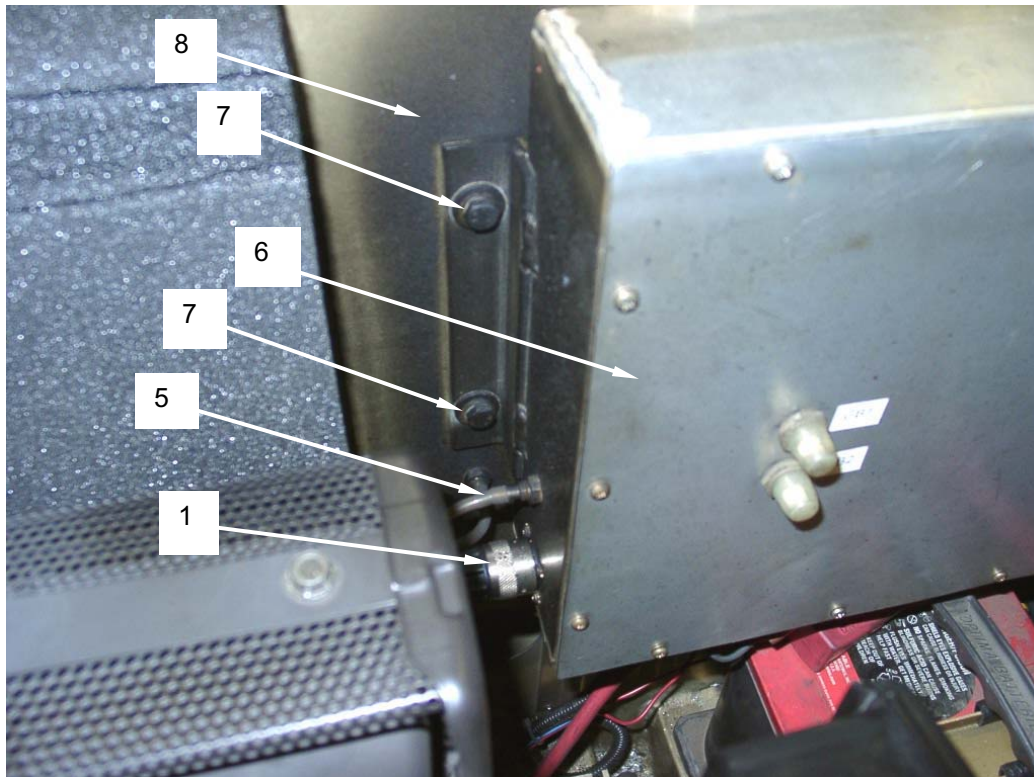

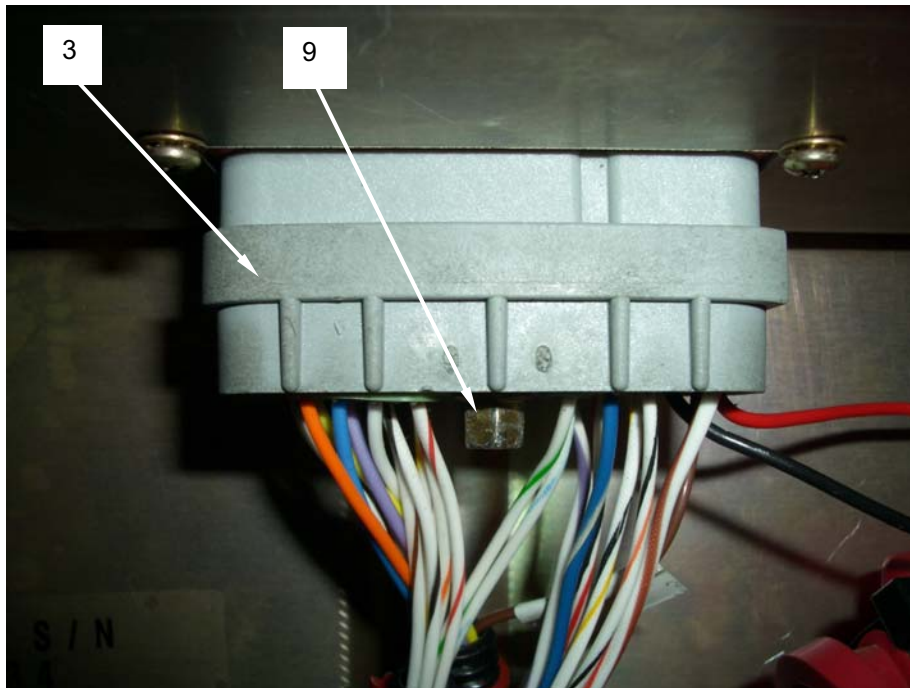
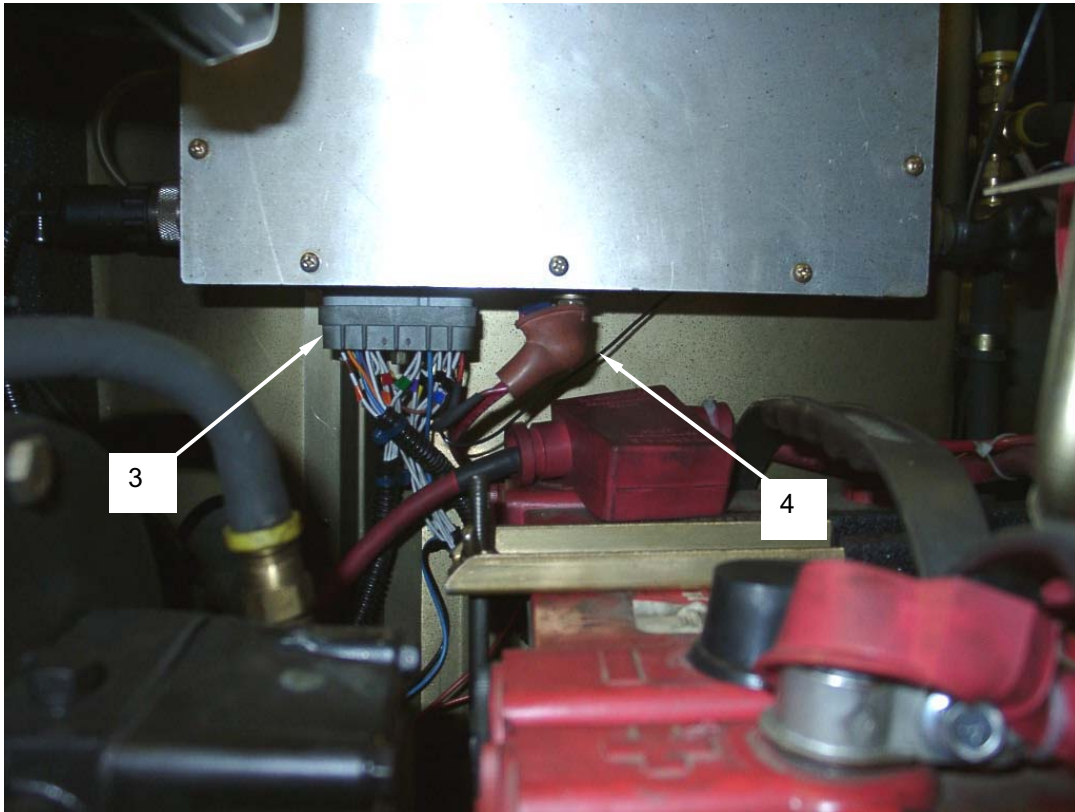

END OF WORK PACKAGE

0063 00-3/(4 Blank)

 FIELD (UNIT) MAINTENANCE

LARGE CAPACITY FIELD HEATER (LCFH)

NSN 4520-01-500-1534

 MECHANICAL HOUR METER
 TEST, REPLACE

INITIAL SETUP:

Tools

Tool Kit, General Mechanics (Item 2, WP 0092 00)

Personnel Required

MOS 63J or 52C

Materials/Parts

Tags, marking (Item 5, WP 0119 00)

Equipment Condition

Heater shut down and cool except during TEST
 Main battery switch OFF and handle removed except during TEST
 Engine bay access door open except during TEST

TEST

1. With the heater off, open the fuel system access door and record the number of hours displayed on the hour meter.
2. Close fuel system access door and start heater. Allow heater to run at least 1 hour and 15 minutes as measured on a wristwatch or other timepiece.
3. Shut heater down and allow to cool.
4. Open fuel system access door and record number of hours displayed on hour meter. If the number of hours has not increased by one hour, replace the hour meter as detailed in the section of this work package entitled REPLACE.

REPLACE**NOTE**

Write down the total number of hours displayed on the front of the hourmeter and report this information to your supervisor so that an accurate record can be maintained of the total hours operated for the heater.

1. Tag and/or mark the two wires leading to the rear of the hourmeter **(1)** on the back side of the fuel panel assembly **(2)**.
2. Remove the two spade connectors **(3)** that attach to the rear of the hourmeter **(1)**.
3. Remove the two screws **(4)** and locknuts **(5)** that secure the hourmeter **(1)** to the fuel panel assembly **(2)**.
4. Remove the defective hourmeter **(1)**.
5. Install a new hourmeter **(1)** through the opening in the fuel panel assembly **(2)**.

REPLACE continued

6. Install two screws (4) and locknuts (5). Tighten securely.
7. Install the two spade connectors (3) on the rear terminals (6) of the hourmeter.

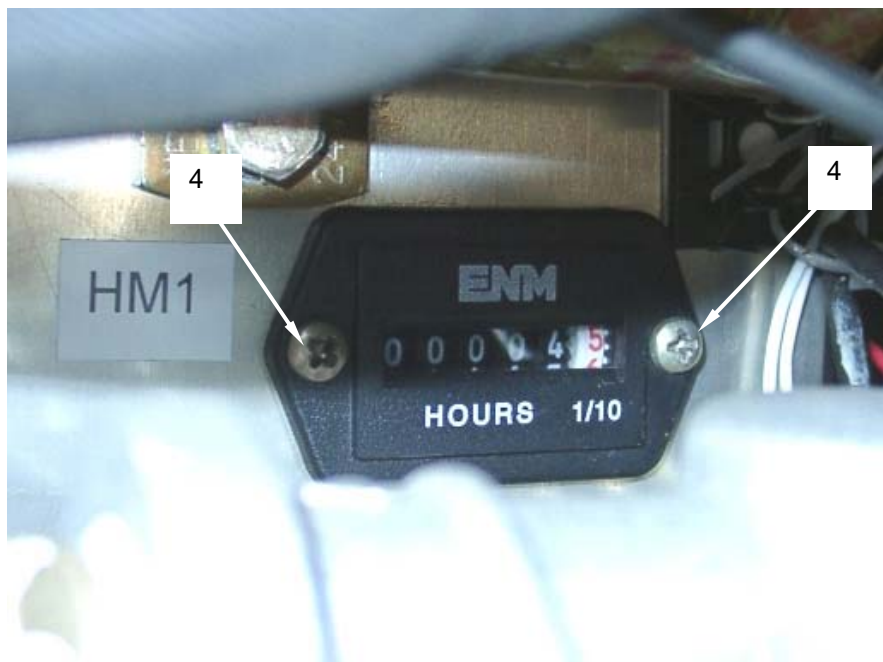
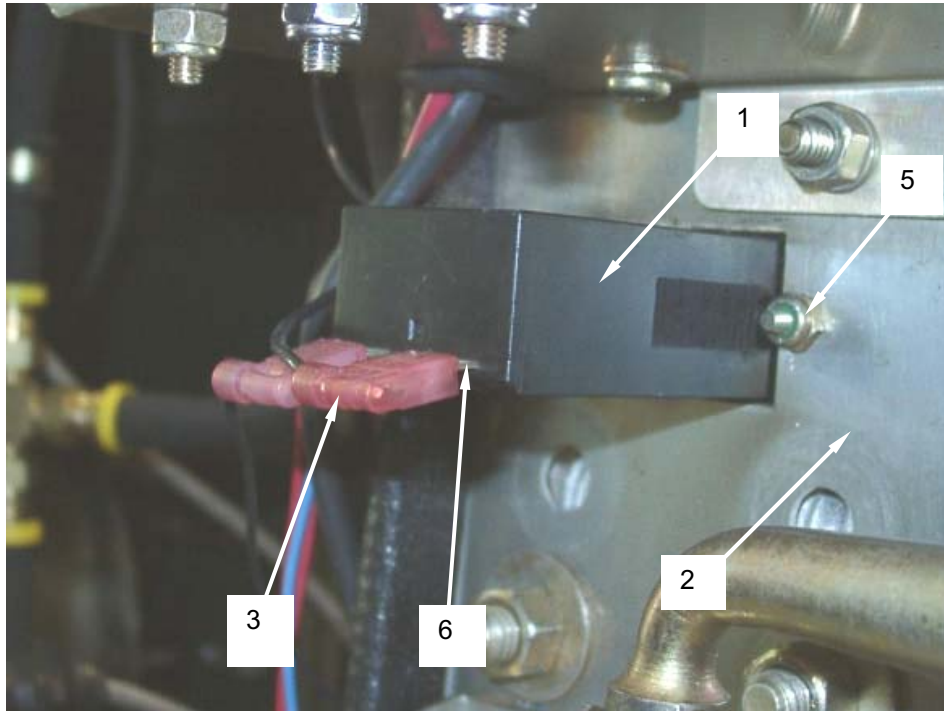
**END OF WORK PACKAGE**

FIELD (UNIT) MAINTENANCE

LARGE CAPACITY FIELD HEATER

NSN 4520-01-500-1534

CARBON MONOXIDE DETECTOR – OPERATOR CONTROL BOX
INSPECT, TEST, REPLACE**INITIAL SETUP:****Tools**

Tool Kit, General Mechanics (Item 2, WP 0092 00)

Personnel Required

MOS 63J or 52C

Materials/Parts

None required

Equipment Condition

Heater powered up and operational for TEST PORTION ONLY (WP 0005 00)
 Heater shut down and cool for REPLACE function (WP 0005 00)
 Main battery switch OFF and handle removed except for TEST

INSPECT**NOTE**

The operator control box mounted carbon monoxide detector must be replaced every 5 years regardless of the results of inspection or test. Refer to the section of this work package entitled REPLACE for complete details on replacement.

Inspect the carbon monoxide detector and cover assembly **(1)** and ensure that it has not been damaged in any way. Ensure that the louvers **(2)** are not blocked or damaged in such a way as to prevent proper airflow into the detector. Ensure that the hinged outer cover **(3)** operates properly. Ensure that the indicator lamp **(4)** is not broken or missing. If the carbon monoxide detector is damaged, replace immediately.

TEST

To test the carbon monoxide detector **(1)**, turn the heater on IAW WP 0005 00. The heater will go through a self test. If a fault is detected with the carbon monoxide detector in the operator control box, a fault code of either H331 or H332 will be displayed on the operator control panel display. Replace a defective carbon monoxide detector as detailed in the section of this work package entitled REPLACE.

REPLACE

1. Remove four screws **(5)** and set aside. Lift the carbon monoxide detector and cover assembly **(1)** from the operator control box **(6)** taking care not to damage the wires.
2. Remove cover **(7)** by removing four screws **(8)**.
3. Tag and mark the three wires **(9, 10, and 11)** that connect to the CO detector terminal strip.
4. Loosen the three screws **(12)** on the terminal strip and remove the three wires **(9, 10, and 11)**.

5. Remove the defective carbon monoxide detector and cover assembly (1) from the operator control box (6).
6. If damaged, remove the rubber gasket (13) and discard.
7. If necessary, install a new rubber gasket (13) aligning the holes in the gasket with the holes in the operator control box hinged cover (3).
8. Install a new carbon monoxide detector and cover assembly (1) by connecting the three wires (9, 10, and 11) to the three screws (12) on the terminal strip. Be sure to match the labels on the wires to the labels on the terminal strip. Tighten screws (12) on terminal strip securely.
9. Mount cover (7) by installing four screws (8).
10. Install the carbon monoxide detector and cover assembly (1) in position on the operator control box (6), aligning the holes on the assembly with the holes in the control box (6).
11. Install the four screws (5) removed earlier and tighten securely.

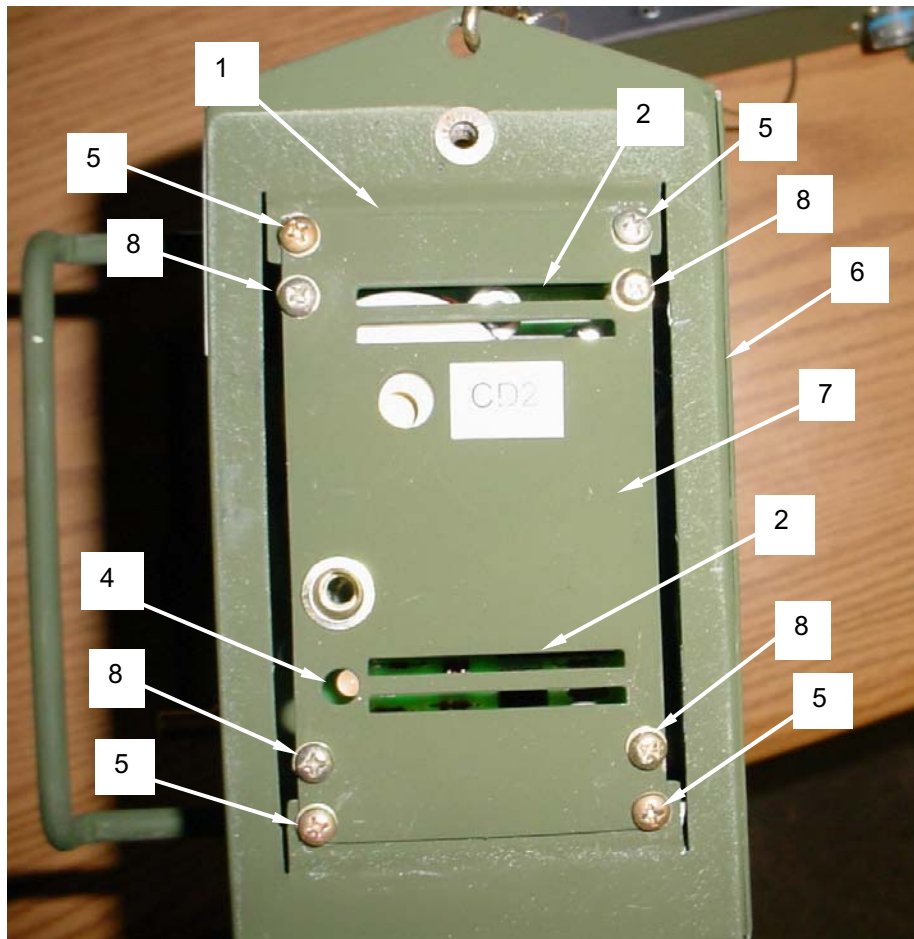

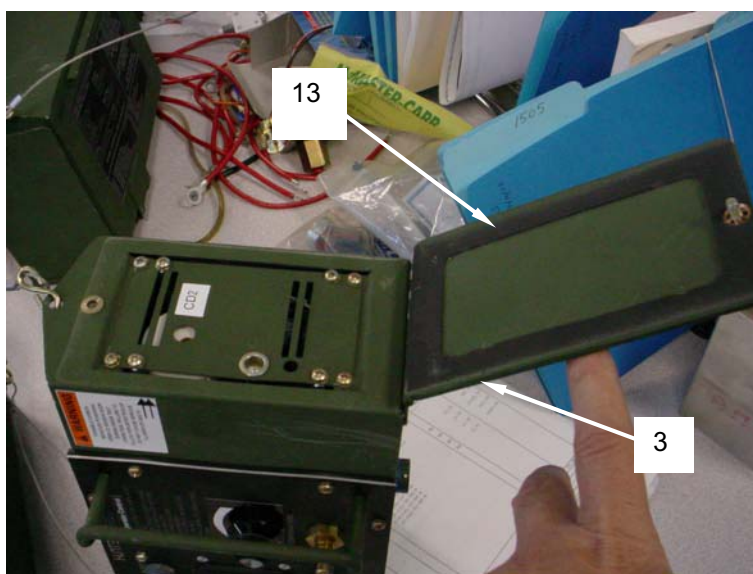
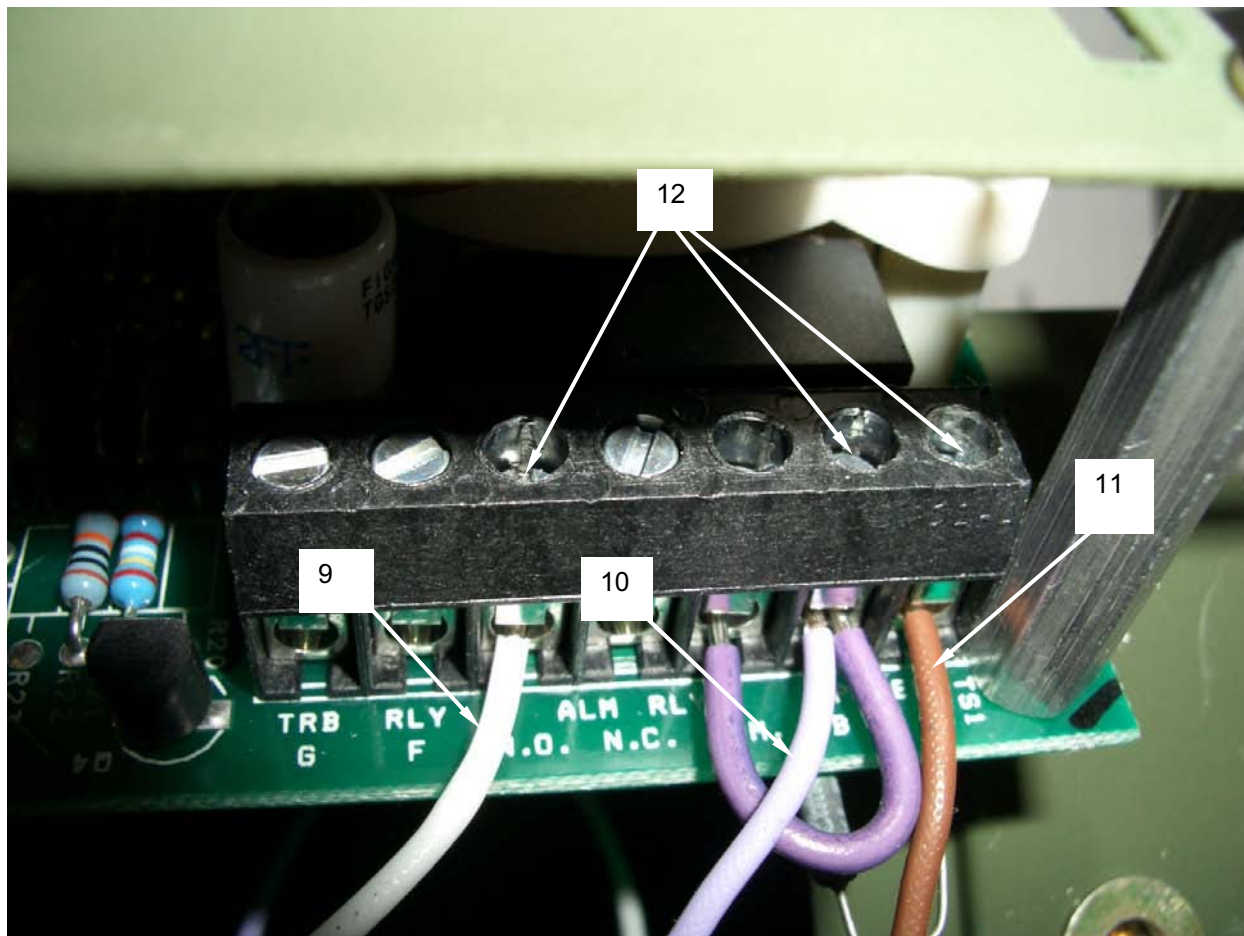

END OF WORK PACKAGE

FIELD (UNIT) MAINTENANCE
LARGE CAPACITY FIELD HEATER (LCFH)**NSN 4520-01-500-1534**
**INSULATED AIR DUCT, 16IN X 15FT
INSPECT, REMOVE, REPAIR**

INITIAL SETUP:**Tools**

Tool Kit, General Mechanics (Item 2, WP 0092
00)

Personnel Required

MOS 63J or 52C

Materials/Parts

Tape, Duct (Item 27, WP 0119 00)

Equipment Condition

Heater shut down and cool.

NOTE

The following procedures apply to both the inlet and outlet ducts.

INSPECT

1. Inspect the inlet and outlet ducts **(1)** for cuts, abrasions, or other damage that would permit air to enter or exit the side walls of the ducts. Repair any rips or cuts in the duct before using.
2. Inspect the internal stow bar **(2)** for dents or other damage that would prevent the duct from being stowed properly.

REMOVE

1. To remove the inlet or outlet duct **(1)** from the heater, untie the tent duct tunnel ties and remove the ducts from the inlet or outlet tent duct tunnels.
2. At the heater duct opening **(3)**, push in and rotate the duct end ring **(4)** clockwise to disengage the end ring **(4)**. Pull the duct **(1)** straight out from the heater.

REPAIR

1. To repair rips, tears, or cuts in the fabric covering of the duct, cover with at least two layers of duct or similar tape, overlapping the edges of the cut or tear by at least two inches.
2. If damage to the duct is excessive and it is not practical to repair with tape, the duct should be replaced.

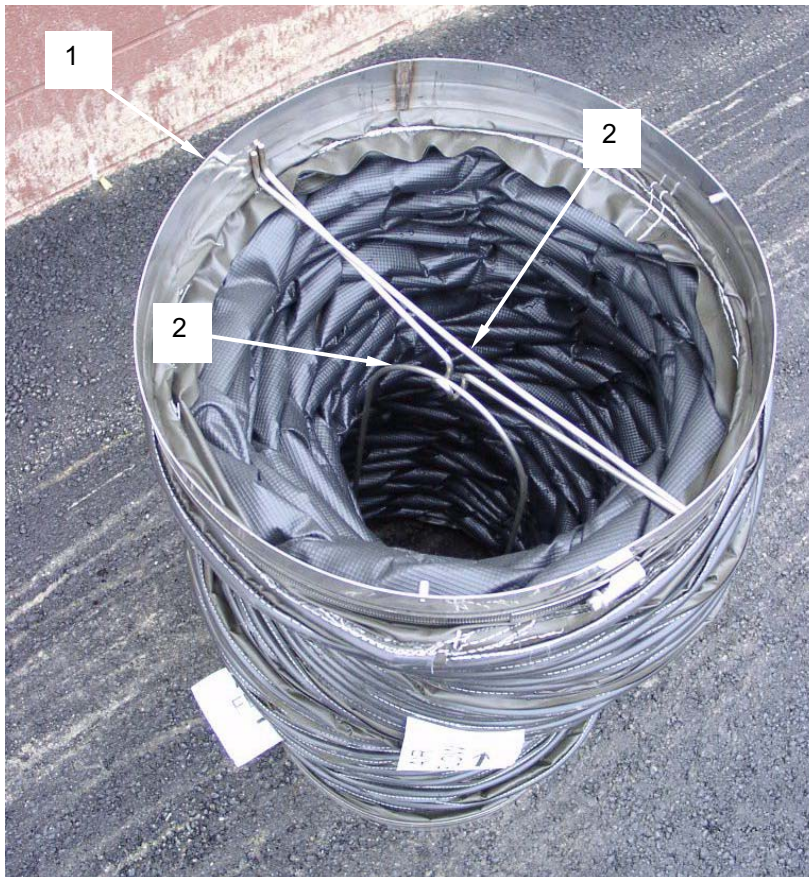
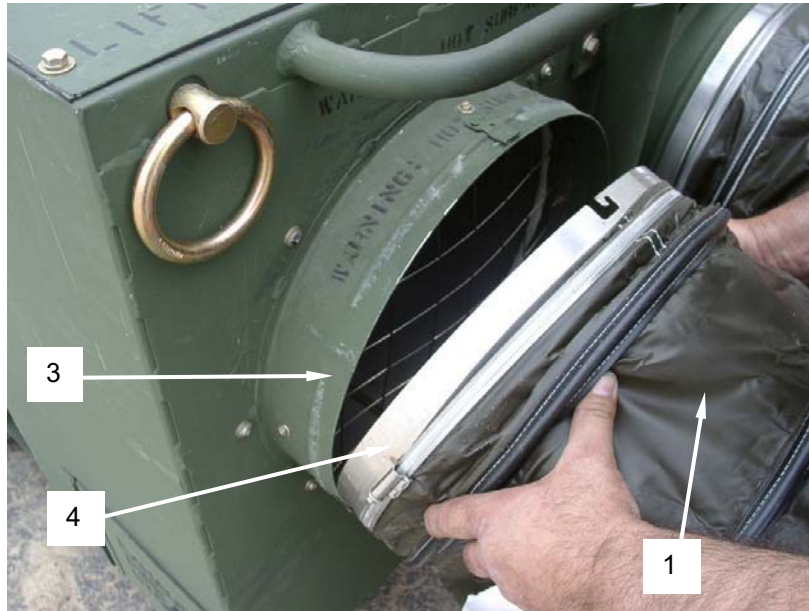

END OF WORK PACKAGE

 FIELD (UNIT) MAINTENANCE

LARGE CAPACITY FIELD HEATER (LCFH)

NSN 4520-01-500-1534

 HEAT EXCHANGER EXHAUST TUBE
 INSPECT, REPAIR

INITIAL SETUP:**Tools**

Tool Kit, General Mechanics (Item 2, WP 0092
00)

Personnel Required

MOS 52C or 63J

Materials/Parts

None required

Equipment Condition

Heater shut down and cool.
 Engine bay access door open.
 Main battery switch OFF and handle removed.

INSPECT

1. Inspect the heat exchanger exhaust tube **(1)** to ensure that there is not extensive carbon buildup on the inside surface.
2. Ensure that it is not dented or bent in such a way as to prevent a secure and leakproof connection between the heat exchanger exhaust tube and the exhaust pipe port on the top of the heater.
3. Ensure that the top rain guard **(2)** is present and has not been damaged in such a way as to prevent the proper flow of exhaust gases from the heat exchanger exhaust tube.
4. Ensure that the burn guard **(3)** is not bent or damaged and that it would adequately protect an operator from coming in contact with a hot exhaust tube during operation.

REPAIR

Repair any dents or bends in the heat exchanger exhaust tube by tapping from the inside with a hammer or other tool. If a dent prevents the proper flow of exhaust gases from the heater and the dent cannot be properly repaired, the heat exchanger exhaust tube should be replaced.

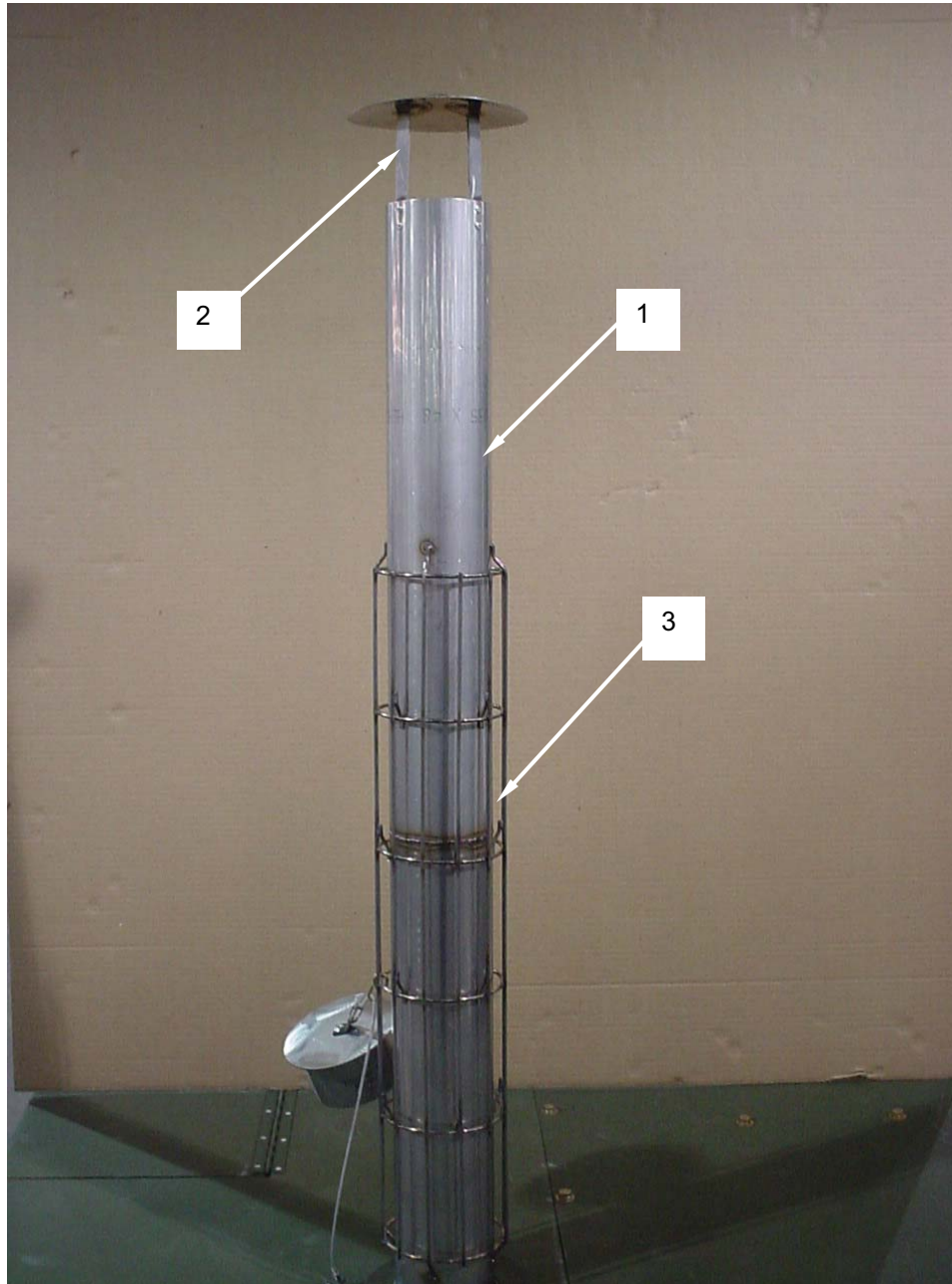

END OF WORK PACKAGE

FIELD (UNIT) MAINTENANCE**LARGE CAPACITY FIELD HEATER (LCFH)****NSN 4520-01-500-1534****EXTERNAL FUEL HOSE ASSEMBLY
INSPECT, REPAIR**

INITIAL SETUP:**Tools**

Tool Kit, General Mechanics (Item 2, WP 0092 00)

Personnel Required

MOS 52C or 63J

Materials/Parts

Rags, wiping (Item 4, WP 0119 00)

Equipment ConditionHeater shut down and cool.
Engine bay access door open.
Main battery switch OFF and handle removed.

INSPECT

1. Inspect the fuel hose **(1)** and fittings **(2)** for any cuts, abrasions, dents, or other damage that may cause the fuel hose to leak.
2. Ensure that all dust caps **(3)** are present, undamaged, and installed when the external fuel hose is not in use.

REPAIR

1. Repair a damaged fuel hose fitting **(2)** by wrapping a rag around the fuel hose just below the fitting to be replaced.
2. Grasping the hose over the rag with pliers.
3. Grasp the fitting **(2)** to be replaced with pliers and twist off.
4. Install a new fitting **(2)** by pushing onto the end of the fuel hose until fully inserted.

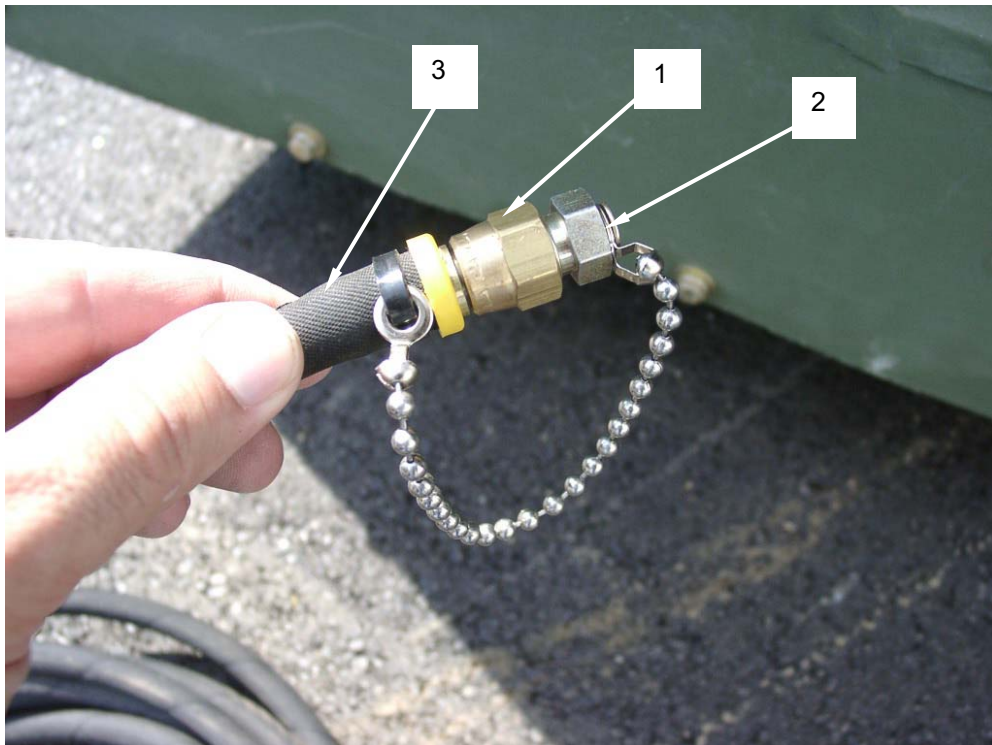
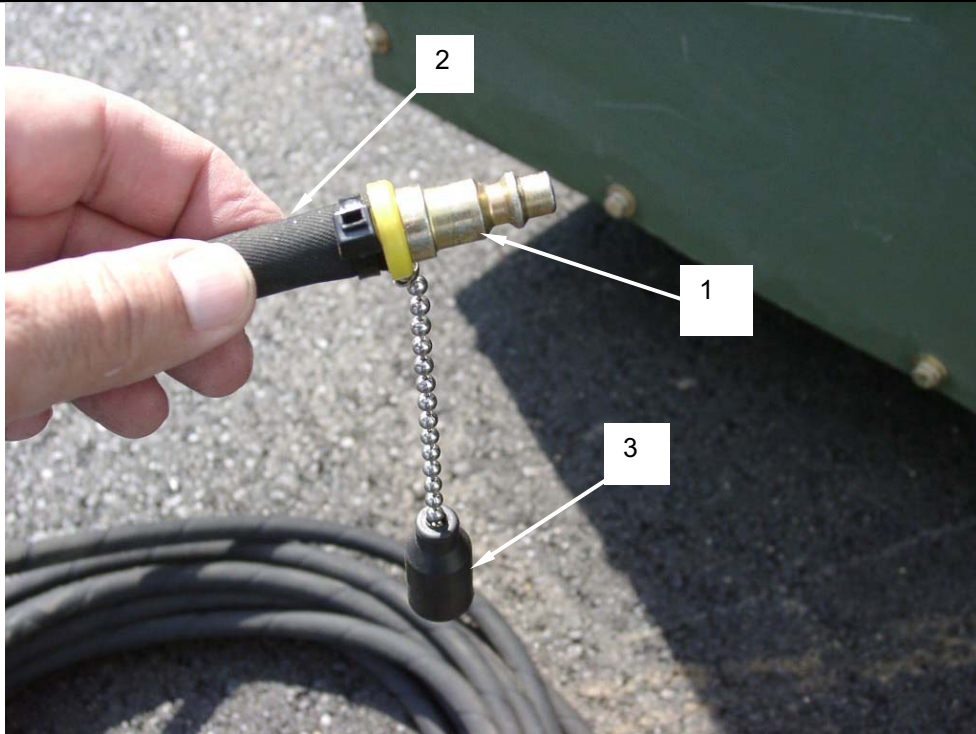

END OF WORK PACKAGE

**FIELD (UNIT) MAINTENANCE
LARGE CAPACITY FIELD HEATER (LCFH)
NSN 4520-01-500-1534
PREPARATION FOR SHIPMENT AND STORAGE**

INITIAL SETUP:**Tools**

None required

Materials/Parts

None required

Personnel Required

MOS 63J or 52C

Equipment Condition

Heater shut down and cool.

Main battery switch to OFF and handle removed.

References

AR 750-1

WP 0041 00

WP 0046 00

Unit SOP(s) on Fuel and Oil Disposal

GENERAL

This section provides instructions for short or long term storage, or shipment, of the LCFH assembly.

ADMINISTRATIVE STORAGE

Administrative storage shall be IAW AR 750-1.

SHORT TERM STORAGE (30 DAYS OR LESS)

1. Check engine oil level and service as required.
2. Cap all disconnected fuel lines.
3. Check that the Fuel Filler Port Cap, Exhaust Cap, Duct Covers and Operator Control Box Door are securely installed so that rain and debris cannot enter.
4. The preferred location for storage is in a covered, level, and protected area. However, the LCFH may be stored uncovered outdoors if necessary.

LONG TERM STORAGE (MORE THAN 30 DAYS)**Preparing the LCFH for Storage**

1. Start the LCFH in Vent mode and operate for 3 minutes, then shut it down.

WARNING

Lubricating Oil, Engine, is an irritant to the eyes and skin. Skin and eye protection required. If overexposed, seek medical attention. Consult with local bioenvironmental engineer for disposal of materials and empty containers.

2. Drain the engine oil while engine is still warm IAW WP 0046 00. Dispose of old oil IAW unit SOP.
3. Fill engine crankcase with fresh oil IAW WP 0046 00.
4. Remove head cover (WP 0041 00). Add 2 cubic centimeters (cc) of engine oil to the cylinder head, then reinstall cover.

WARNING

Fuel Oil, Diesel, is flammable and an irritant to the eyes, skin and upper respiratory tract. Skin and eye protection required. Keep off of eyes, skin and clothing. Do not ingest. MSA approved organic vapor cartridge respirator or adequate ventilation required. Keep away from sparks or open flames. Consult with local bioenvironmental engineer for disposal of materials and empty containers.

5. Drain all fuel from the LCFH Tank.
6. Clean any spilled fuel and re-use or dispose of old fuel IAW unit SOP.
7. Remove the negative battery cable from the battery post located near the Engine Access Door.

NOTE

The fluid drained from the Heat Exchanger is a mixture of fuel and water, and should be disposed of properly. Do not drain the fluid on to the ground or into the local sewer system.

8. Drain the Heat Exchanger into an approved container and dispose of the fluid IAW unit SOP.
9. Shut all access doors and close all vent openings.

10. Store the LCFH ducts in a dry, sheltered place if possible.

During Long Term Storage

At least once every two months, the system batteries should be charged with a constant voltage trickle charge rated at 2 amps. As an alternative, the batteries may be placed indefinitely on a float charge of no more than 1 amp at 13.2 to 13.8 VDC.

RETURNING THE LCFH TO OPERATION

1. Perform PMCS.

NOTE

The fluid drained from the Heat Exchanger is a mixture of fuel and water, and should be disposed of properly. Do not drain the fluid on to the ground or into the local sewer system.

2. If the LCFH was stored outside, drain the Heat Exchanger into an approved container and dispose of the fluid IAW unit SOP.
3. Check the voltage at each battery. If the battery voltage is below 10.0 VDC, the battery may be sulfated, and may not be recoverable. Any battery that is below 12.6 VDC should be recharged with a constant voltage charger that operates between 14.4 and 14.8 VDC. The charging time should continue two hours after the charging current has dropped below 3.0 amps, and could last up to two days.
4. Following charging, the batteries may be load tested if the proper equipment is available. Load the battery to 50 percent of the battery's rated CCA level for 15 seconds. If the voltage at the end of the test is less than 9.6 VDC, the battery should be replaced.
5. Start the LCFH in VENT mode and allow it to run for 15 minutes while checking for fuel leaks.
6. Place the LCFH into Manual mode and ensure that the burner lights successfully.
7. Operate in Manual mode for 15 minutes while checking for fuel leaks.
8. Correct any leaks or malfunctions prior to deployment.

SHIPMENT

1. Prepare engine for short or long term storage, as applicable.
2. Attach all forms, tags, and records to LCFH assembly.
3. Mark for shipment IAW MIL-STD-129.

END OF WORK PACKAGE

CHAPTER 7
DIRECT SUPPORT TROUBLESHOOTING INSTRUCTIONS
LARGE CAPACITY FIELD HEATER (LCFH)

**FIELD (DIRECT) SUPPORT MAINTENANCE
LARGE CAPACITY FIELD HEATER (LCFH)
MALFUNCTION SYMPTOM INDEX**

GENERAL

This chapter provides information to permit the operator to troubleshoot some problems that may occur during the operation of the LCFH.

MALFUNCTION SYMPTOM INDEX

The malfunction symptom index lists common malfunctions that may occur during the operation of the Large Capacity Field Heater. Find the malfunction to be eliminated and go to the indicated troubleshooting table in work package 0071 00. This index cannot list all malfunctions that may occur, all tests or inspections needed to find the fault, or all actions required to correct the fault. If the existing malfunction is not listed, or cannot be corrected through this troubleshooting index, notify general support maintenance.

Malfunction	Troubleshooting Step
Engine will not start	1
Engine starts and stops.....	2
Engine speed fluctuates (races or uneven speed)	3
Engine output drops	4
Engine runs rough.....	5
Engine emits white smoke	6
Engine emits black smoke	7

**FIELD (DIRECT) SUPPORT MAINTENANCE
LARGE CAPACITY FIELD HEATER (LCFH)
TROUBLESHOOTING PROCEDURES**

INITIAL SETUP:

Tools

Tool Kit, General Mechanics (Item 2, WP 0092 00)

Personnel Required

MOS 63J or 52C

Materials/Parts

None required

Equipment Condition

Heater shut down and cool unless otherwise indicated.

Main battery switch OFF and handle removed.

Table 1. Troubleshooting Procedure for Large Capacity Field Heater (LCFH).

MALFUNCTION	TEST OR INSPECTION	CORRECTIVE ACTION
1. ENGINE WILL NOT START	Step 1. Check for proper thickness of fuel injection pump shim (WP 0074 00).	Step 1. Adjust shim thickness / injection timing (WP 0074 00).
	Step 2. Damaged or defective fuel injection pump.	Step 2. Remove and replace fuel injection pump (WP 0074 00).
		Step 3. Refer problem to general support maintenance level.
2. ENGINE STARTS AND STOPS	Step 1. Check for damaged governor control component (WP 0075 00).	Step 1. Remove and replace damaged control component (WP 0075 00).
	Step 2. Damaged or defective fuel injection pump.	Step 2. Remove and replace fuel injection pump (WP 0074 00).
		Step 3. Refer problem to general support maintenance level.
3. ENGINE SPEED FLUCTUATES (RACES OR UNEVEN SPEED)	Step 1. Check governor control for proper position of regulator spring (WP 0075 00).	Step 1. Adjust governor lever (WP 0075 00).
	Step 2. Damaged or defective governor control component (WP 0075 00).	Step 2. Remove and replace damaged control component (WP 0075 00).
		Step 3. Refer problem to general support maintenance level.
4. ENGINE OUTPUT DROPS	Step 1. Damaged or defective fuel injection pump.	Step 1. Remove and replace fuel injection pump (WP 0074 00).
		Step 2. Refer problem to general

Table 1. Troubleshooting Procedure for Large Capacity Field Heater (LCFH).

MALFUNCTION	TEST OR INSPECTION	CORRECTIVE ACTION
5. ENGINE RUNS ROUGH	<p>Step 1. Check governor control for proper position of regulator spring (WP 0075 00).</p> <p>Step 2. Check for proper thickness of fuel injection pump shim (WP 0074 00).</p> <p>Step 3. Damaged or defective fuel injection pump.</p>	<p>support maintenance level.</p> <p>Step 1. Adjust governor lever (WP 0075 00).</p> <p>Step 2. Adjust shim thickness / injection timing (WP 0074 00).</p> <p>Step 3. Remove and replace fuel injection pump (WP 0074 00).</p> <p>Step 4. Refer problem to general support maintenance level.</p>
6. ENGINE EMITS WHITE OR BLACK SMOKE	<p>Step 1. Check injection timing (too slow) (WP 0074 00).</p>	<p>Step 1. Adjust fuel injection pump timing by removing shims (WP 0074 00).</p> <p>Step 2. Refer problem to general support maintenance level.</p>

CHAPTER 8

FIELD (DIRECT) SUPPORT MAINTENANCE INSTRUCTIONS

LARGE CAPACITY FIELD HEATER (LCFH)

**FIELD (DIRECT) SUPPORT MAINTENANCE
LARGE CAPACITY FIELD HEATER (LCFH)
DIRECT SUPPORT MAINTENANCE**

INTRODUCTION TO DIRECT SUPPORT MAINTENANCE

This section contains Direct Support Maintenance applicable to the Large Capacity Field Heater as authorized by the Maintenance Allocation Chart (MAC), Work Package 0092 00, of this manual. Direct Support Maintenance personnel may also perform all functions allocated in Operator and Unit Maintenance.

All maintenance procedures in this section can be performed by one person unless otherwise indicated. Read all **WARNINGS, CAUTIONS, NOTES**, and instructions carefully before attempting any procedures. Read and understand all warnings at the front of this manual.

Each maintenance action will include a heading which lists the actions to be taken, the tools and parts/materials required, and the condition in which the equipment must be in to perform the action.

All Direct Support maintenance instructions covered in this section are unique to the Large Capacity Field Heater.

**FIELD (DIRECT) SUPPORT MAINTENANCE
LARGE CAPACITY FIELD HEATER (LCFH)
NSN 4520-01-500-1534
CRANKCASE COVER
REMOVE, CLEAN, INSPECT, INSTALL**

INITIAL SETUP:**Tools**

Tool Kit, General Mechanics (Item 2,
WP 0092 00)
Wrench, Torque (Item 12, WP 0092 00)

Personnel Required

MOS 63J or 52C

Materials/Parts

Oil, engine lubricating (Item 25, WP 0119 00)
Rag, wiping, clean (Item 4, WP 0119 00)
Solvent, degreasing (Item 24, WP 0119 00)
Grease, high temperature (Item 22,
WP 0119 00)

Equipment Condition

Heater shut down and cool.
Engine bay access door open.
Main battery switch OFF and handle removed.
Engine oil drained (WP 0046 00)

NOTE

Engine maintenance requires metric tools for the removal of all hardware and assemblies.

REMOVE**CAUTION**

When removing crankcase cover, be careful not to damage oil seal.

1. Note attachment location of engine lifting cable (4). Release crankcase cover (1) and lifting cable from cylinder block by removing fifteen screws (2). Carefully pry crankcase cover from cylinder block by tapping on cover tabs (8) with a metal punch.
2. Remove cover gasket (3). Discard gasket if damaged or deformed. Remove pipe (5), two guide pins (6), and sensor (7) only if replacement is required.

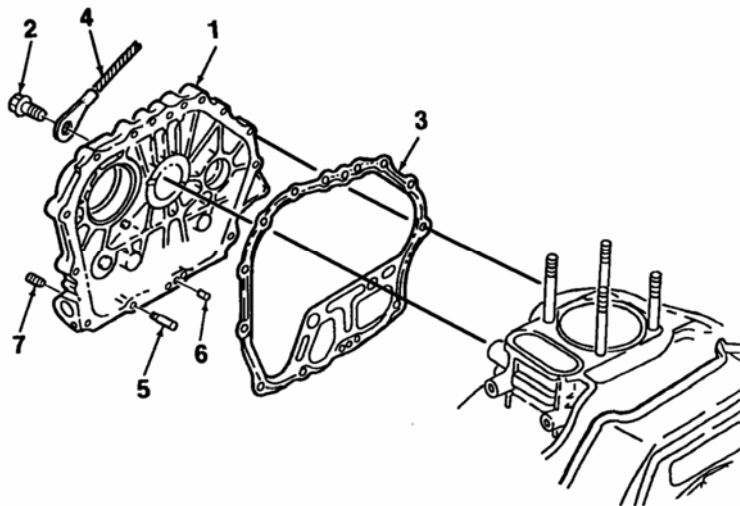

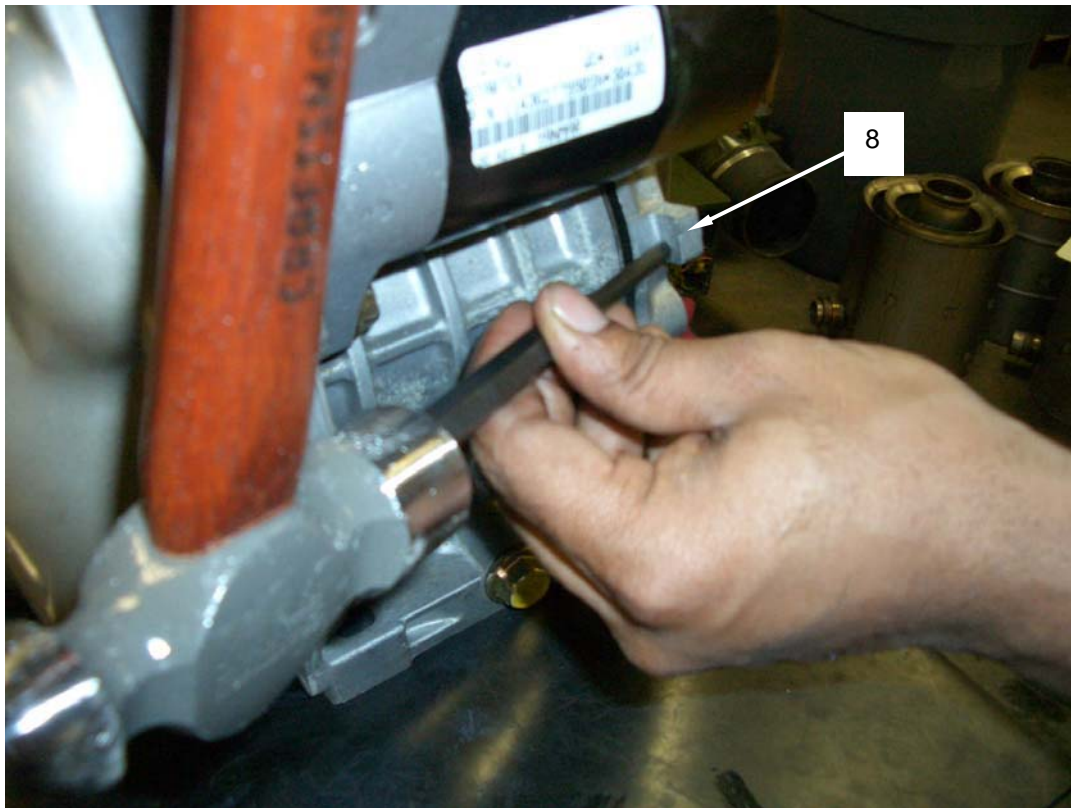

CLEAN**WARNING**

Cleaning solvents are flammable and toxic to eye, skin, and respiratory tract. Skin and eye protections are required when working in contact with cleaning solvents. Avoid repeated or prolonged contact. Work in well ventilated area only. Keep away from heat, sparks, and open flame. Do not smoke while using cleaning solvent. Failure to observe this warning can result in injury or death to personnel.

1. Clean crankcase cover with cleaning solvent and a clean rag. Allow to air dry.
2. Remove any old gasket material or grease from crankcase cover and engine crankcase mating surfaces.

INSPECT

1. Inspect crankcase cover **(1)** for cracks, deformation, or obvious damage. Inspect cover mating surfaces for scratches, burrs, or blemishes. Replace cover if damaged.
2. Inspect cover gasket **(3)** for damage or deformation. Replace if damaged in any way.

INSTALL

1. If removed, install threaded plug **(7)**, pipe **(5)**, and two guide pins **(6)** into crankcase cover **(1)**.
2. Apply grease to lips of crankshaft oil seal (housed in crankcase cover **(1)**).
3. Apply oil to crankshaft and camshaft. Make sure that oil pump drive gears are properly engaged.
4. Mate cover gasket **(3)** to cylinder block.

NOTE

It will be easier to install the crankcase cover by lightly pushing down on the cover while slowly rotating the flywheel.

5. Mate crankcase cover **(1)** to cylinder block and secure using fifteen screws **(2)**. Make sure to attach lifting cable **(4)** at position noted during removal. Tighten screws in criss-cross sequence as shown in accompanying illustration. Torque all screws to 174 to 199 inch-pounds (200 to 230 kg-cm).
6. Service engine oil (WP 0046 00).

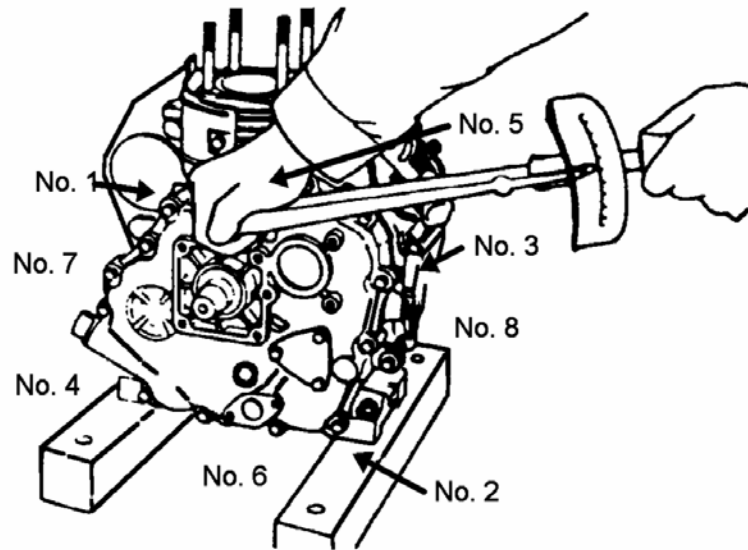

END OF WORK PACKAGE

**FIELD (DIRECT) SUPPORT MAINTENANCE
LARGE CAPACITY FIELD HEATER (LCFH)
NSN 4520-01-500-1534
FUEL INJECTION PUMP
REMOVE, SERVICE, INSPECT, INSTALL, ADJUST**

INITIAL SETUP:**Tools**

Tool Kit, General Mechanics (Item 2, WP 0092 00)
Wrench, Torque (Item 19, WP 0092 00)

Personnel Required

MOS 63J or 52C

Materials/Parts

Oil, engine lubricating (Item 25, WP 0119 00)
Rag, wiping, clean (Item 4, WP 0119 00)
Solvent, degreasing (Item 24, WP 0119 00)
Shims, Timing (Item 26, WP 0119 00), as required

Equipment Condition

Heater shut down and cool.
Engine bay access door open.
Main battery switch OFF and handle removed.

NOTE

Engine maintenance requires metric tools for the removal of all hardware and assemblies.

REMOVAL

1. Disconnect rigid fuel line (1) and fuel hose (2) from fuel injection pump (3).
2. Remove nut (4), inspection cover (5), and gasket (6) from lower pump stud (7).
3. Remove fuel injection pump (3) from upper pump studs (8) by removing two nuts (9). Remove shim(s) (10). Note number of shims utilized.
4. Remove fuel tappet (11) from engine crankcase.

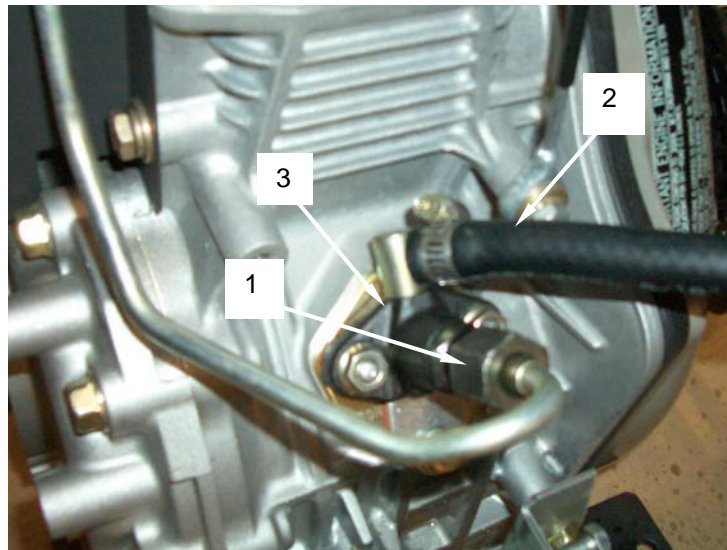

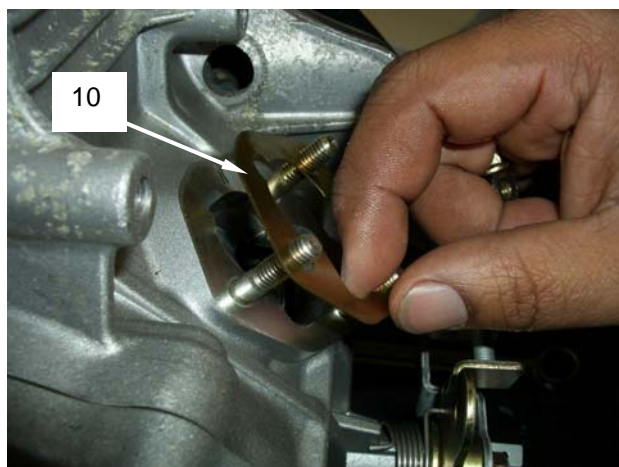
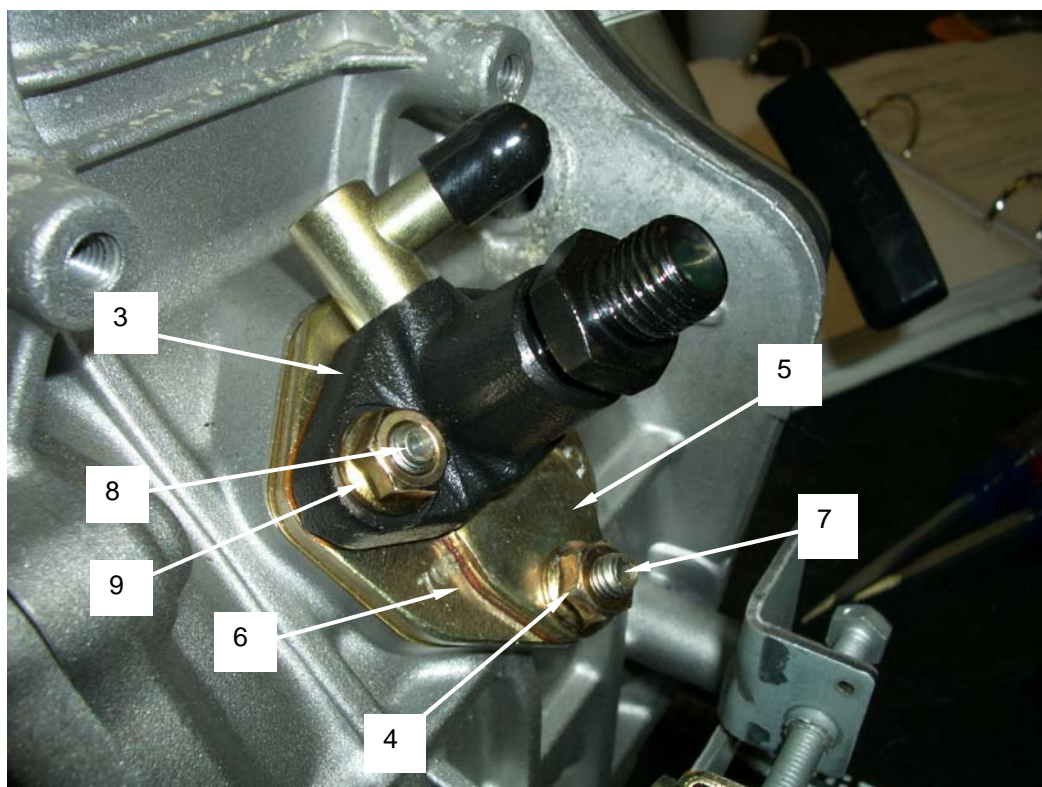

SERVICE**WARNING**

Cleaning solvents are flammable and toxic to eye, skin, and respiratory tract. Skin and eye protections are required when working in contact with cleaning solvents. Avoid repeated or prolonged contact. Work in well ventilated area only. Keep away from heat, sparks, and open flame. Do not smoke while using cleaning solvent. Failure to observe this warning can result in injury or death to personnel.

Clean components with cleaning solvent and a clean rag. Allow to air dry.

INSPECTION

1. Inspect rigid fuel line **(1)** and fuel hose **(2)** for cracks, kinks, and leaks. Inspect injection pump **(3)** for crossed, stripped, or damaged threads. Replace if damaged.
2. Inspect fuel tappet **(11)** for scores, pitting, or wear. Replace if damaged or worn.

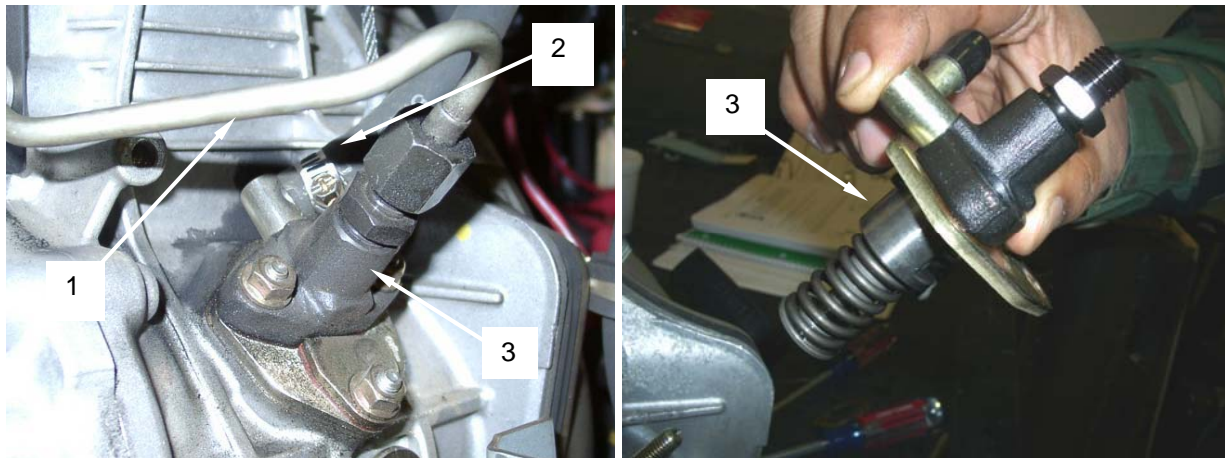

INSTALLATION

1. Install fuel tappet (11) into engine crankcase.
2. Install shim(s) (10) onto injection pump studs (7 and 8).
3. Install injection pump (3) onto upper studs (8), aligning tooth (12) on control lever with slot on governor lever (13). Governor lever must be set so slot is in the center of opening in housing. Install nuts (9) and torque to 87 to 104 inch-pounds (100 to 120 kg-cm).
4. Install gasket (6), cover (5), and nut (4) on lower stud (7). Torque to 87 to 104 inch-pounds (100 to 120 kg-cm).

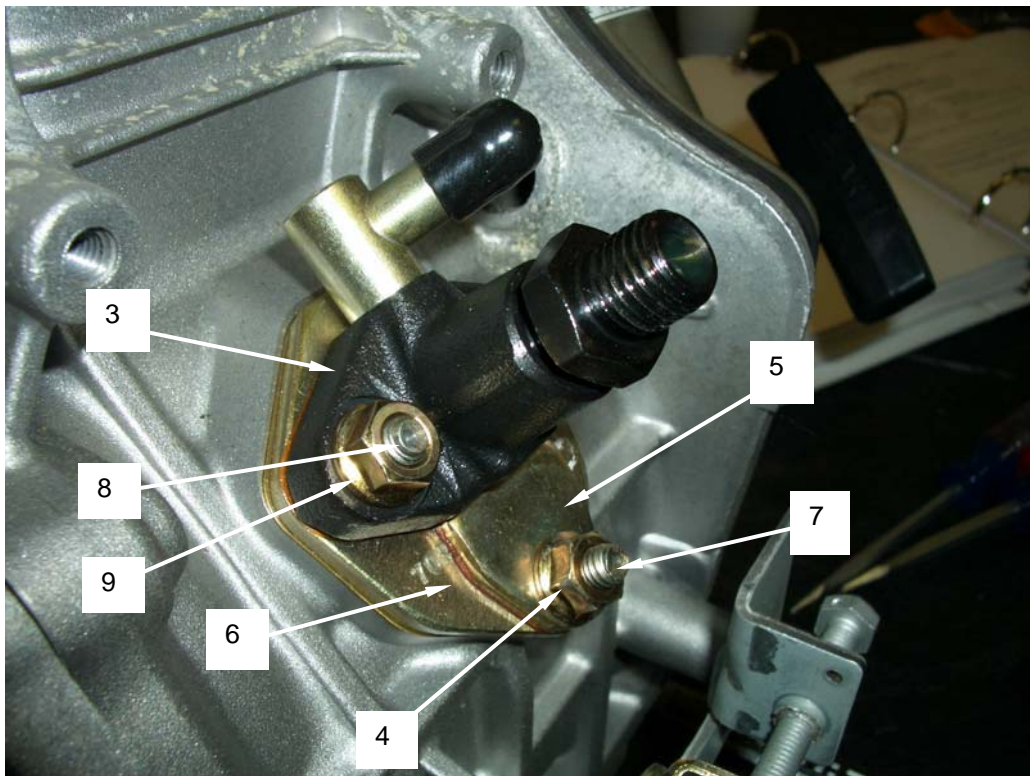
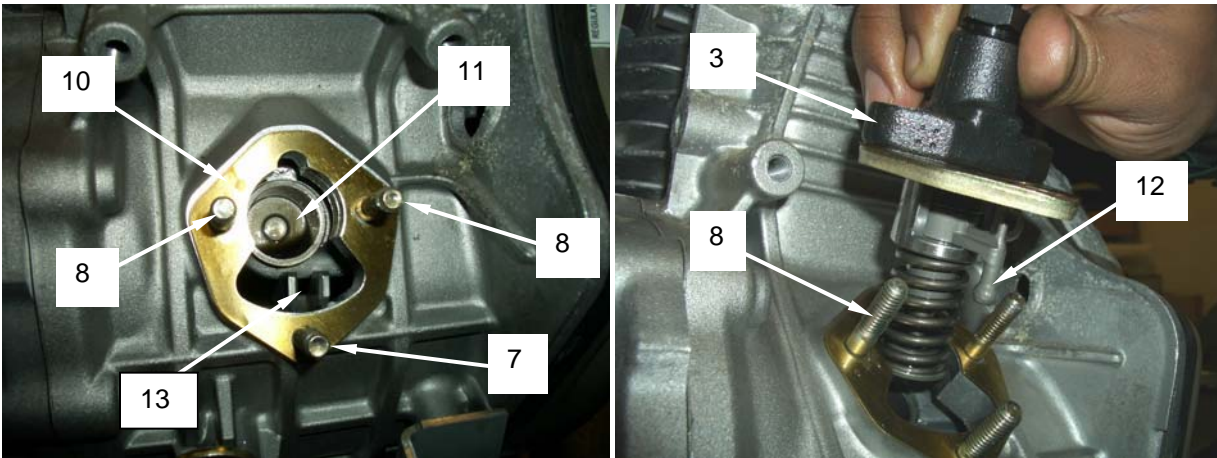

5. Adjust fuel injection timing in accordance with section of this work package entitled FUEL INJECTION TIMING ADJUSTMENT before connecting rigid fuel pipe (1) and fuel hose (2) to injection pump (3).

FUEL INJECTION TIMING ADJUSTMENT

1. Remove flywheel housing (WP 0045 00). Disconnect rigid fuel pipe (1) and fuel hose (2) from injection pump (3) if not removed earlier.
2. Set governor speed control handle to RUN position.
3. Rotate flywheel one revolution in the clockwise direction until T position mark (13) on flywheel matches V mark (14) off line on cylinder body fin. This is the top dead center (TDC) position. There should be some fuel coming out of the fuel injection pump. If fuel is not present, rotate the flywheel another revolution clockwise.
4. Turn flywheel counter-clockwise about 30 degrees from T position mark.
5. Slowly turn flywheel clockwise until fuel flows from injection pump, then stop rotation.
6. Use timing marks on flywheel to determine flywheel position. Marks are 5 degrees apart. Flywheel should be 16 to 18 degrees before TDC position. Therefore, the V mark off line should be aligned between the third and fourth flywheel timing marks before the TDC position mark.
7. Repeat steps 4 through 6 two or three times to make sure reading is accurate. Fuel injection should begin when flywheel is rotated 16 to 18 degrees from TDC position mark.

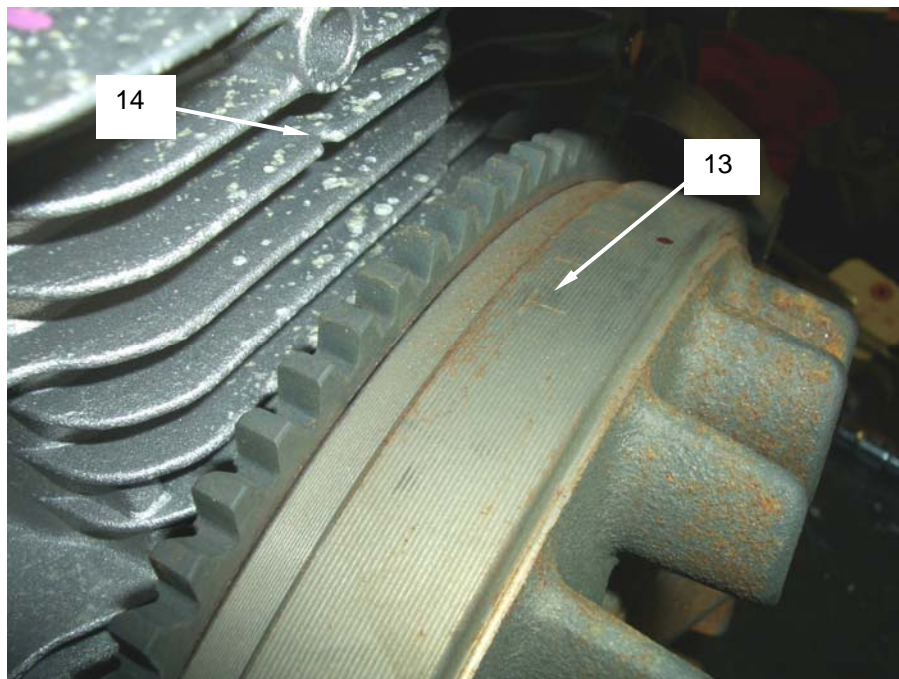

8. Injection timing can be adjusted by adding or removing injection pump shims (**10**). If fuel is injected before a 16 degree rotation, add shims. If fuel is not injected until after a 18 degree rotation, subtract shims. Each 0.1 mm (0.0039 inch) shim changes timing by 1 degree.
9. Add or subtract shims (**10**) as required and retest to ensure proper timing. Install rigid fuel pipe (**1**) and fuel hose (**2**) onto injection pump (**3**). Install flywheel housing (WP 0045 00).

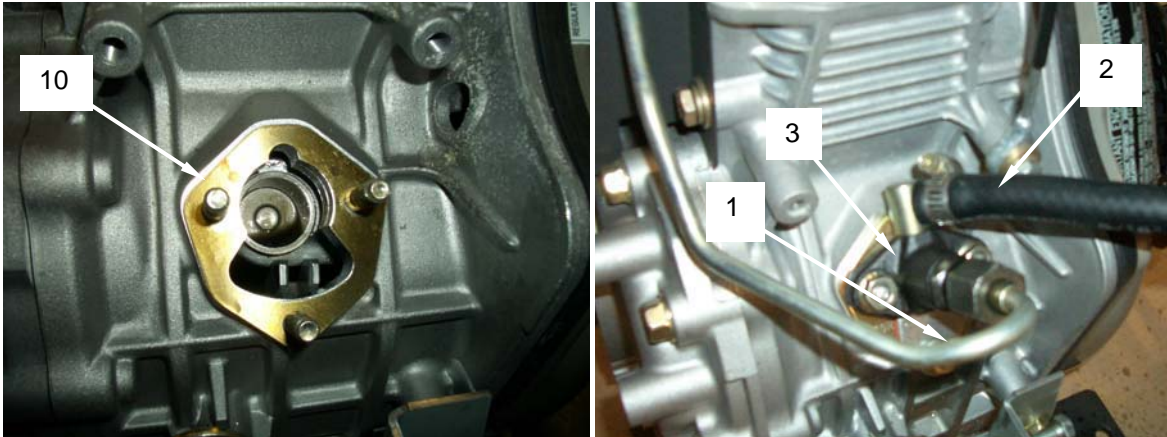

END OF WORK PACKAGE

FIELD (DIRECT) SUPPORT MAINTENANCE**LARGE CAPACITY FIELD HEATER (LCFH)****NSN 4520-01-500-1534****GOVERNOR CONTROL
REMOVE, SERVICE, INSPECT, INSTALL**

INITIAL SETUP:**Tools**

Tool Kit, General Mechanics (Item 2, WP 0092 00)

Personnel Required

MOS 63J or 52C

Materials/PartsSolvent, degreasing (Item 24, WP 0119 00)
Rag, wiping, clean (Item 4, WP 0119 00)**Equipment Condition**Heater shut down and cool.
Engine bay access door open.
Main battery switch OFF and handle removed.

NOTE

Engine maintenance requires metric tools for the removal of all hardware and assemblies.

REMOVAL**CAUTION**

Governor lever (7) and torque spring are factory preset. Do not adjust locking nut or cut lockwire.

1. Remove adjusting screw (1) and washer (2) from regulator bracket assembly (3).
2. Mark the position of springs (4, 5) and disconnect springs (4, 5) from governor lever (7) and manual control handle (6).
3. Release regulator bracket assembly (3) from cylinder block by removing screw (8).
4. Remove screw (9), knob (10), and nut (11). Remove screw (13) and spring (12).

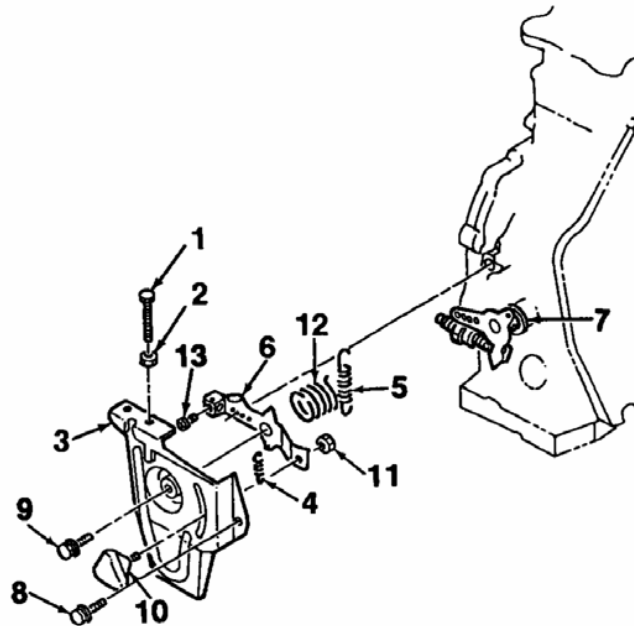

SERVICE



WARNING

Cleaning solvents are flammable and toxic to eye, skin, and respiratory tract. Skin and eye protections are required when working in contact with cleaning solvents. Avoid repeated or prolonged contact. Work in well ventilated area only. Keep away from heat, sparks, and open flame. Do not smoke while using cleaning solvent. Failure to observe this warning can result in injury or death to personnel.

Clean components with cleaning solvent and a clean rag. Allow to air dry.

INSPECT

Inspect governor control components for damage. Replace any part that is damaged in any way.

INSTALL

1. Install screw (1) onto manual control handle (6). Mate handle to regulator bracket assembly (3) and install screw (9), knob (10), nut (11), and spring (12).
2. Mate regulator bracket assembly (3) to cylinder block and install screw (8). Connect springs (4, 5) to handle (6) and lever (7). Ensure that spring (5) is connected to control handle (6) and governor lever (7) exactly as shown. One end of spring installs in second hole from left on governor lever (7) and opposite end of spring installs in first hole on control handle (6).
3. Install screw (1) and washer (2).

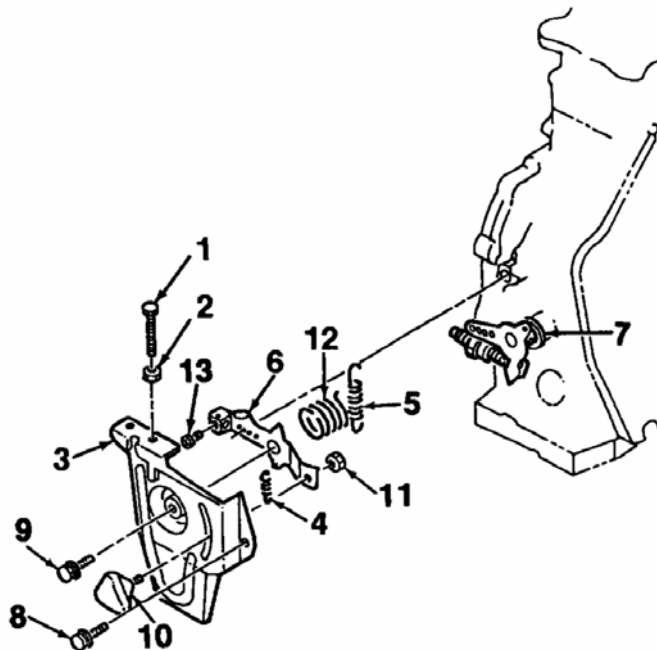
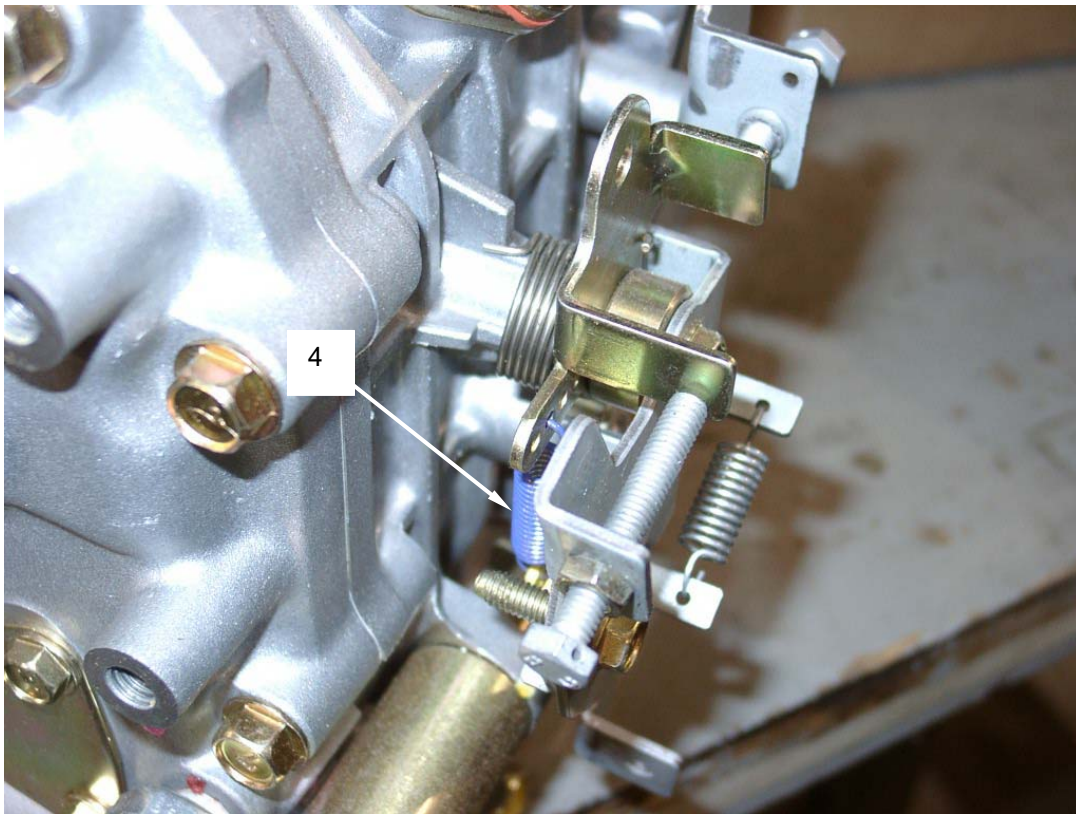

END OF WORK PACKAGE

FIELD (DIRECT) SUPPORT MAINTENANCE
LARGE CAPACITY FIELD HEATER (LCFH)

NSN 4520-01-500-1534

OIL PUMP
REMOVE, SERVICE, INSPECT, INSTALL

INITIAL SETUP:**Tools**

Tool Kit, General Mechanics (Item 2, WP 0092 00)
 Wrench, Torque (Item 12, WP 0092 00)
 Micrometer, Caliper (Item 13, WP 0092 00)

Personnel Required

MOS 63J or 52C

Materials/Parts

Oil, engine lubricating (Item 25, WP 0119 00)
 Rag, wiping, clean (Item 4, WP 0119 00)
 Solvent, degreasing (Item 24, WP 0119 00)
 Grease, high temperature (Item 22, WP 0119 00)

Equipment Condition

Heater shut down and cool.
 Engine bay access door open.
 Main battery switch OFF and handle removed.
 Engine oil drained (WP 0046 00)

NOTE

Engine maintenance requires metric tools for the removal of all hardware and assemblies.

REMOVE**CAUTION**

When removing crankcase cover, be careful not to damage oil seal.

1. Release crankcase cover from cylinder block and remove cover gasket IAW WP 0073 00. Discard gasket if damaged or deformed.
2. Remove oil pump cover (1) from crankcase cover (2) by removing three screws (3). Remove and discard O-ring (4).

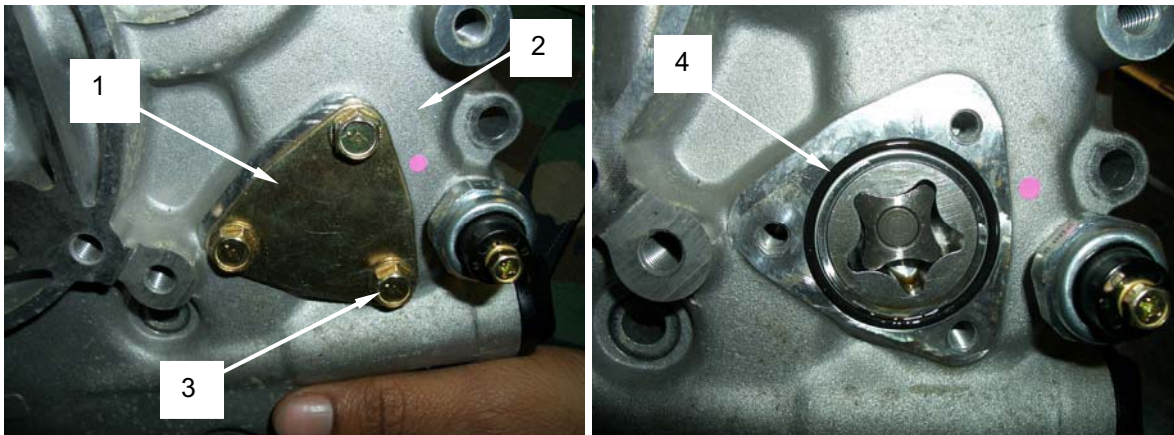

0076 00-1

3. Remove the two arms (5) of the governor assembly (6) by removing two pins (7).
4. Remove cap (8) on end of shaft (9).
5. Remove governor assembly (6) by pulling from shaft (9).
6. Remove pin (10) that extends through shaft (9).
7. Slide oil pump assembly (11) out through front of crankcase cover (2). Remove outer rotor (12). Discard governor assembly (6) and cap (8).

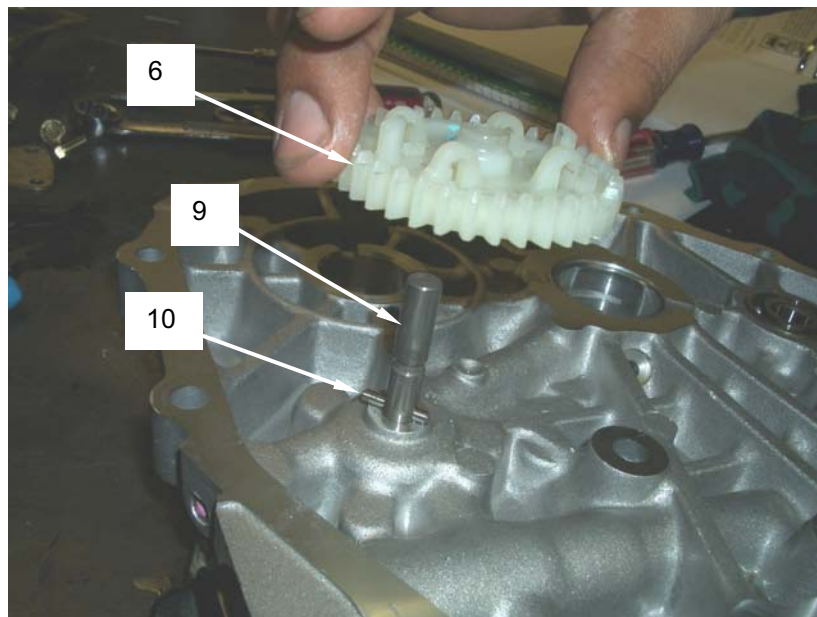
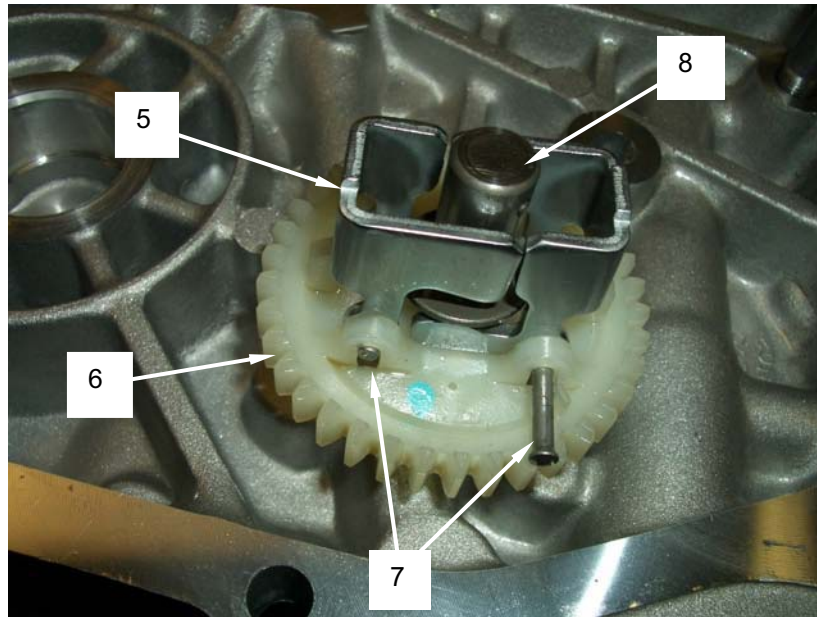



SERVICE



WARNING

Cleaning solvents are flammable and toxic to eye, skin, and respiratory tract. Skin and eye protections are required when working in contact with cleaning solvents. Avoid repeated or prolonged contact. Work in well ventilated area only. Keep away from heat, sparks, and open flame. Do not smoke while using cleaning solvent. Failure to observe this warning can result in injury or death to personnel.

1. Clean components with cleaning solvent and a clean rag. Allow to air dry.

INSPECT

1. Inspect crankcase cover **(2)** for cracks, deformation, or obvious damage. Inspect mating surfaces for scratches, burrs, or blemishes. Replace cover if damaged.
2. Inspect cover gasket for damage or deformation. Replace if damaged in any way.
3. Inspect outer rotor **(12)** and inner rotor portion **(13)** of oil pump **(11)** for signs of excessive or uneven wear. Fit inner rotor into outer rotor and measure gap at various points. Gap between inner and outer rotors must not exceed 0.0098 inch (0.25 mm). Replace outer rotor **(12)** and oil pump **(11)** as an assembly if excessively worn, damaged, or out of limits.
4. Measure the outside diameter (OD) of outer rotor **(12)**. OD must be 1.1378 inches (28.90 mm), minimum. Replace outer rotor **(12)** and oil pump **(11)** as an assembly if out of limits.

5. Measure the internal diameter (ID) of outer rotor port in crankcase cover (1). ID must not exceed 1.1488 inches (29.18 mm). Replace crankcase cover (2) if out of limits.



INSTALL

1. Insert oil pump (11) into crankcase cover (2) and install pin (10) through shaft (9). Coat oil pump inner rotor (13) with oil, and install outer rotor (12).
2. Coat new O-ring (4) with oil and install into crankcase cover (2). Install oil pump cover (1) using three screws (3).
3. Install new governor assembly (6) and cap (8) onto shaft (9).
4. Install the two arms (5) of the governor assembly (6) by installing two pins (7).
5. Apply grease to lips of crankshaft oil seal (installed in crankcase cover (2)).
6. Apply oil to crankshaft and camshaft. Make sure that oil pump drive gears are properly engaged.
7. Mate cover gasket to cylinder block.
8. Install crankcase cover (2) and gasket IAW WP 0073 00.
9. Service engine oil IAW WP 0046 00.

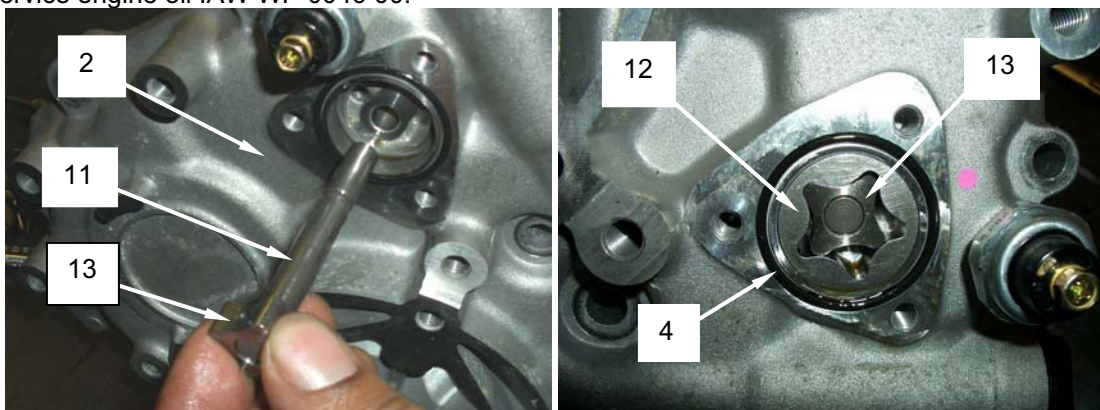

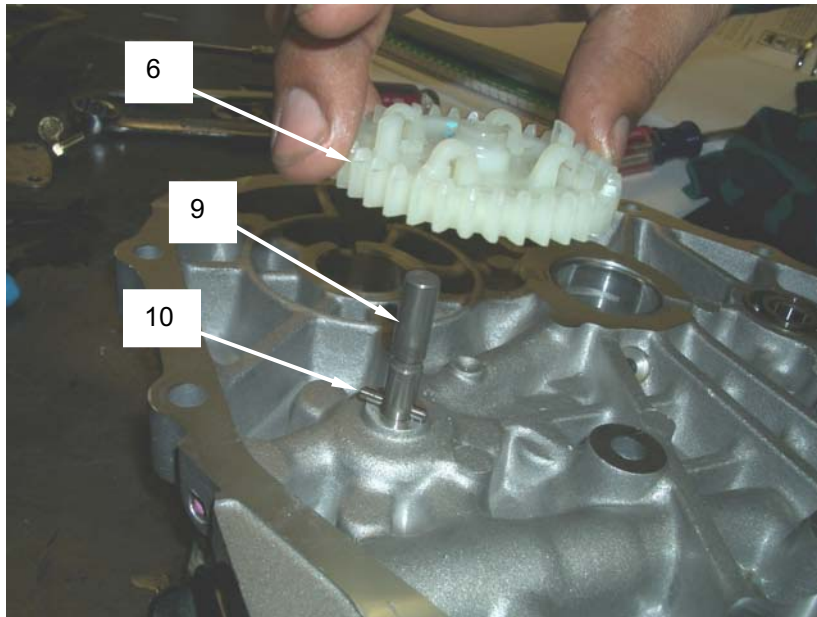
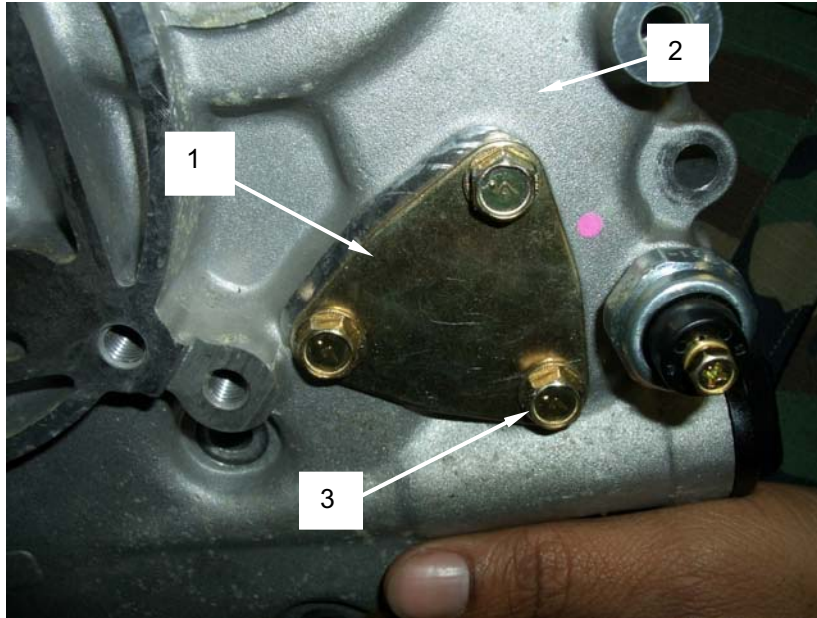

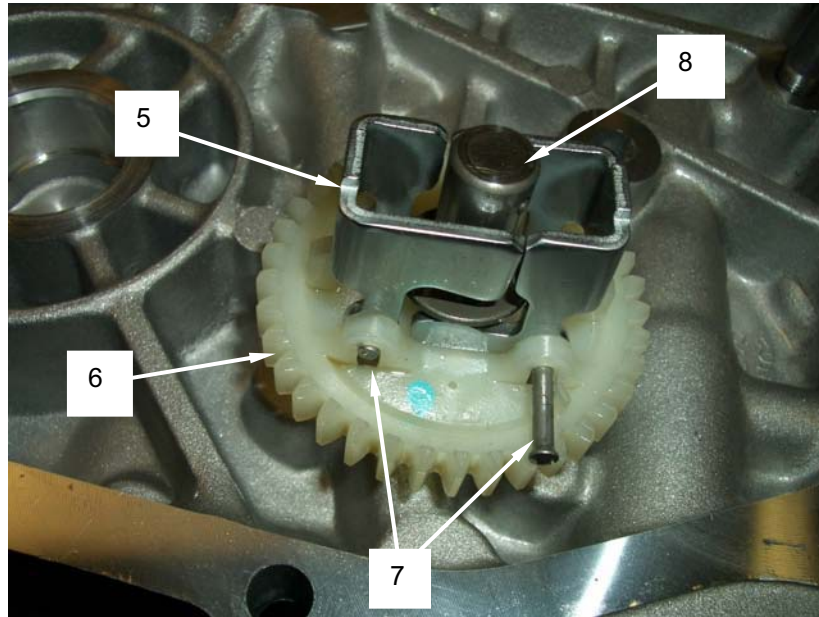

END OF WORK PACKAGE

**FIELD (DIRECT) SUPPORT MAINTENANCE
LARGE CAPACITY FIELD HEATER (LCFH)
NSN 4520-01-500-1534
ROCKER ARM ASSEMBLY
REMOVE, INSPECT, INSTALL**

INITIAL SETUP:**Tools**

Tool Kit, General Mechanics (Item 2, WP 0092 00)
Wrench, Torque (Item 12, WP 0092 00)
Micrometer, Caliper (Item 13, WP 0092 00)

Personnel Required

MOS 63J or 52C

Materials/Parts

Solvent, degreasing (Item 24, WP 0119 00)
Rag, wiping, clean (Item 4, WP 0119 00)

Equipment Condition

Heater shut down and cool.
Engine bay access door open.
Main battery switch OFF and handle removed.
Rocker cover removed (WP 0041 00)

NOTE

Engine maintenance requires metric tools for the removal of all hardware and assemblies.

REMOVAL

1. Remove rocker arm support **(1)** from cylinder head **(2)** by removing two bolts **(3)**. Place assembled support and rocker arms on a clean work surface for further disassembly.
2. Remove rocker arms **(4 and 5)** from rocker arm support **(1)**. Remove lock nuts **(6)**, adjusting screws **(7)**, and valve cap **(8)**.
3. Ensure that intake and exhaust valve components **(9)** remain together.

CLEANING**WARNING**

Cleaning solvents are flammable and toxic to eye, skin, and respiratory tract. Skin and eye protection are required when working in contact with cleaning solvents. Avoid repeated or prolonged contact. Work in well ventilated area only. Keep away from heat, sparks, and open flame. Do not smoke while using cleaning solvent. Failure to observe this warning can result in injury or death to personnel.

Clean rocker arm components with cleaning solvent and a clean rag. Allow to air dry.

INSPECTION

1. Measure the outside diameter (OD) of the rocker arm support shaft **(10)** (see illustration). OD must be 0.4685 inch (11.90 mm), minimum. Replace support **(1)** if out of limits.
2. Measure the internal diameter (ID) of the rocker arms. ID must be 0.4764 in (12.10 mm), maximum. Replace rocker arm **(4 and 5)** if out of limits.

INSTALLATION

1. Install lock nuts **(6)** and adjusting screws **(7)** onto rocker arms **(4 and 5)**. Install valve caps **(8)**. Install rocker arms onto rocker arm support **(1)**.
2. Install rocker arm support **(1)** onto cylinder head **(2)** using two bolts **(3)**. Torque bolts to 174 to 199 inch-pounds (200 to 230 kg-cm).
3. Adjust valve clearance IAW WP 0041 00.
4. Install rocker cover IAW WP 0041 00.

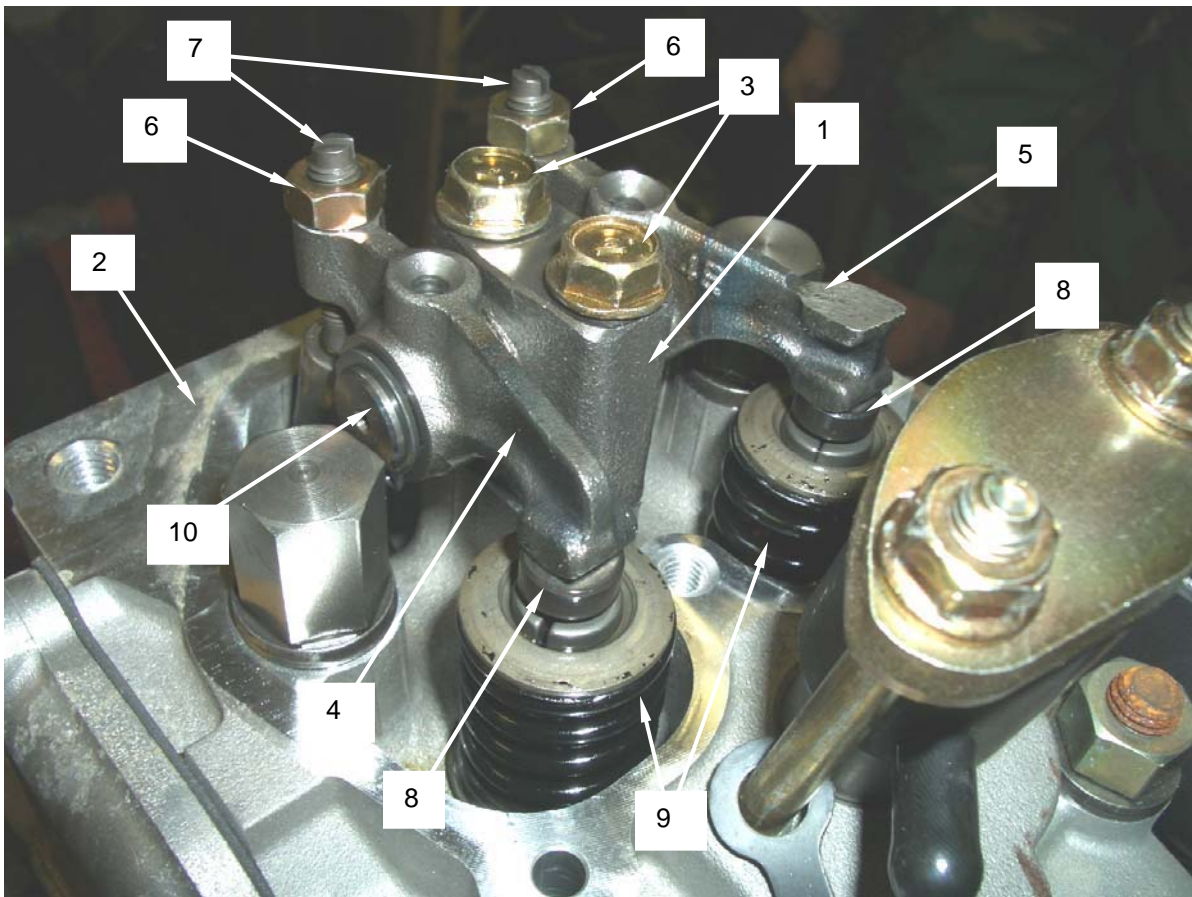

Measuring outside diameter of rocker arm support shaft.

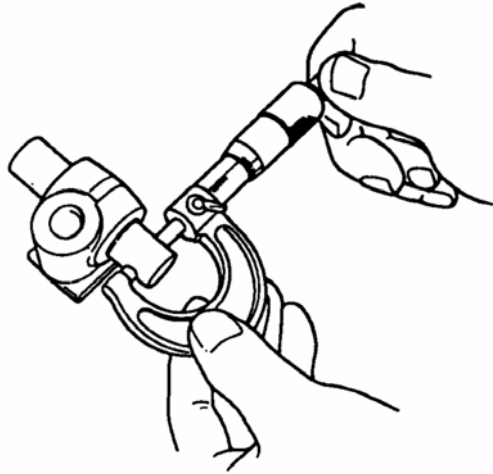

Measuring internal diameter of rocker arms.

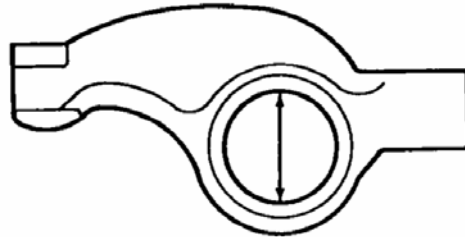

END OF WORK PACKAGE

**FIELD (DIRECT) SUPPORT MAINTENANCE
LARGE CAPACITY FIELD HEATER (LCFH)
NSN 4520-01-500-1534
DIESEL ENGINE
REPLACE**

INITIAL SETUP:**Tools**

Tool Kit, General Mechanics (Item 2, WP 0092 00)
Wrench, Torque (Item 12, WP 0092 00)
Lift, chain (Item 18, WP 0092 00)

Materials/Parts

Pin, cotter (Item 30, WP 0119 00)

Personnel Required

MOS 63J or 52C

Equipment Condition

Heater shut down and cool.
Engine bay access door open.
Main battery switch OFF and handle removed.
Drain all fuel from fuel tank.

NOTE

Engine maintenance requires metric tools for the removal of all hardware and assemblies.

REPLACE

1. Remove the top engine compartment cover **(1)** by removing the eighteen hex head bolts and lockwashers **(2)**. Set hardware and top engine compartment cover aside.



2. Disconnect and remove batteries (3) IAW WP 0058 00 in order to provide better access to engine compartment area.
3. Mark and disconnect wires connected to the starter (4) and sending unit (5) on engine (6).
4. Loosen clamp (7) and disconnect flexible exhaust tube (8) from engine muffler (9).

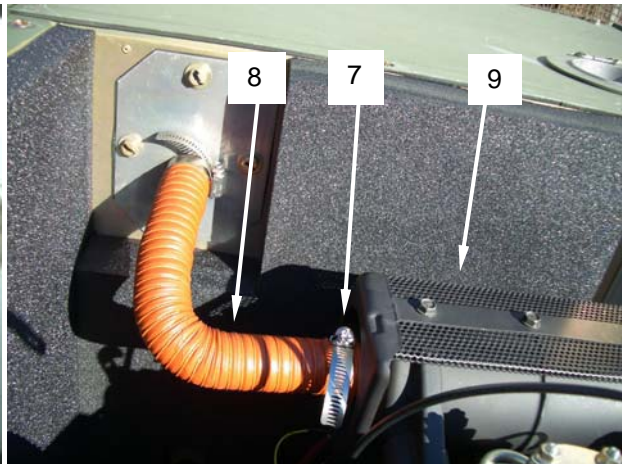
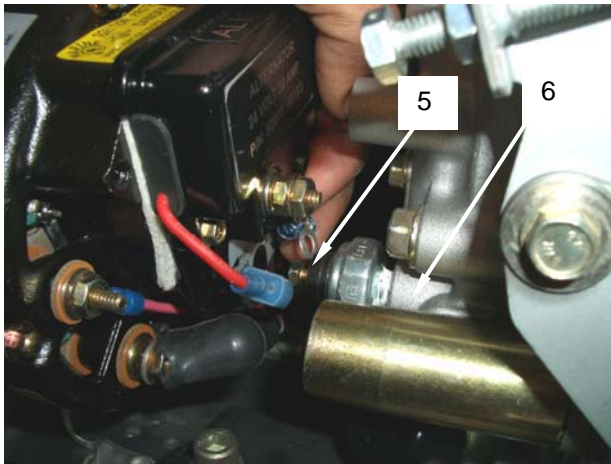

5. Disconnect engine shutdown solenoid cable (10) by removing cotter pin (11) and sliding retaining pin (12) from end of cable (10). Discard cotter pin.
6. Remove fuel line clamp (13) near midpoint of engine by removing bolt securing the clamp to engine block. Leave clamp attached to fuel line and set mounting bolt aside.
7. Close burner fuel pump shutoff valve (14).
8. Remove fuel hose (15) from tee connector (16). Catch any fuel in approved container. Wipe up any spilled fuel with a rag.

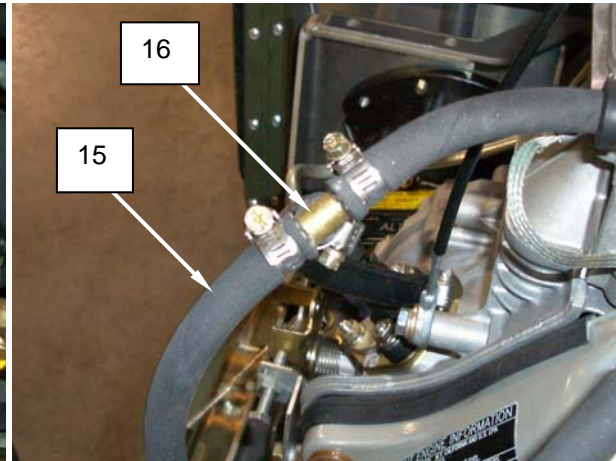
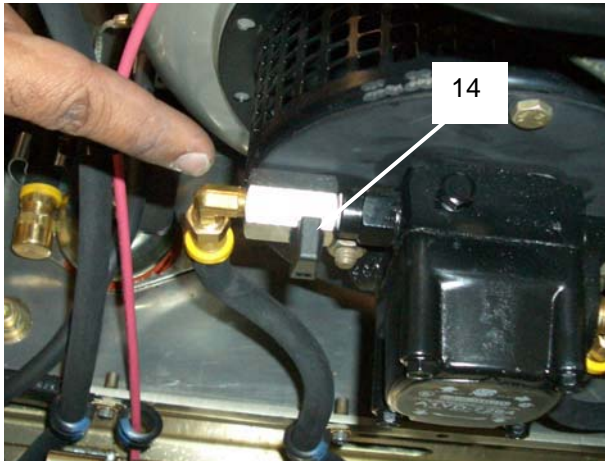
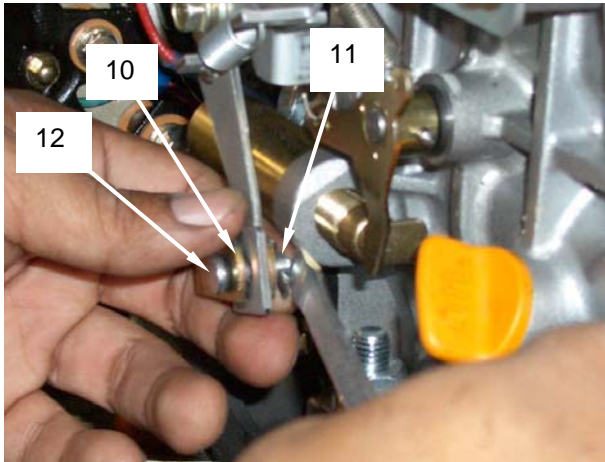

9. Remove the dust boot and disconnect the cable (17) attached to the point labeled GP1 (18) on the side of the engine intake manifold.
10. Remove nut (19) and remove black battery cable (20) and grounding strap (21) from mounting stud at base of engine. Push battery cable and grounding strap off to the side of the engine compartment.
11. Disconnect fuel line (22) connected to burner fuel pump shutoff valve (14).
12. Disconnect fuel line (23) connected to fitting (24) on underside of burner fuel pump (25).

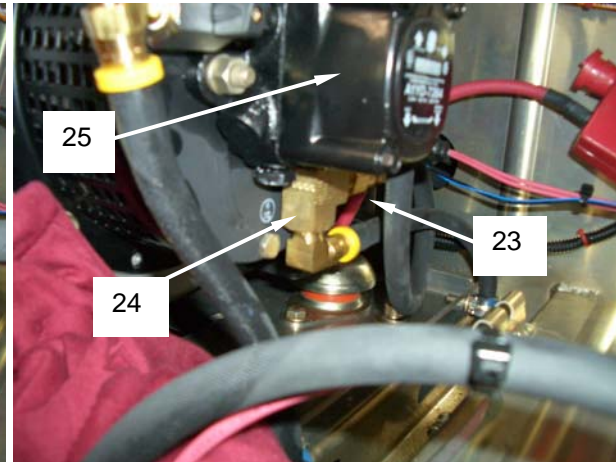
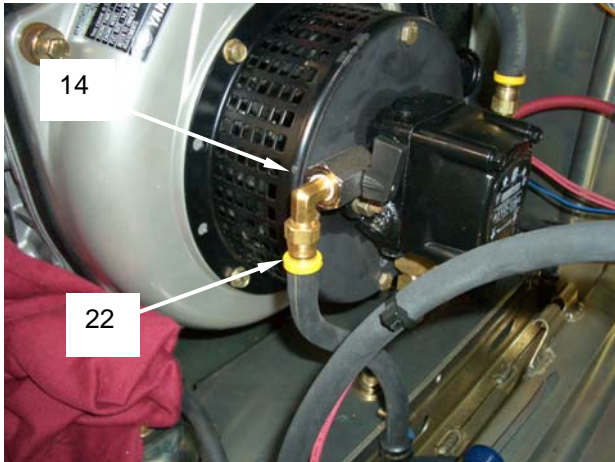
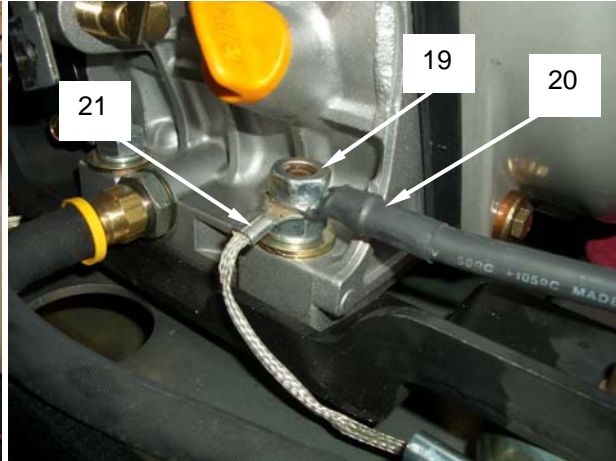
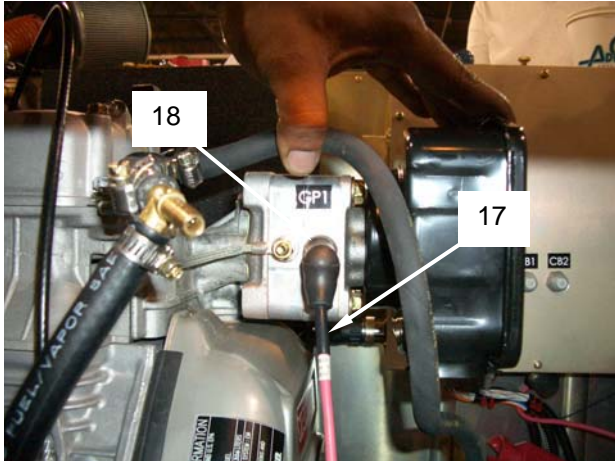

13. Remove the four socket cap head screws (26) that secure the engine mounting bracket (27) to the engine vibration mounts (28).
14. Loosen clamp and remove air intake hose (29) from engine. Move hose off to side.
15. Remove engine oil drain hose (30) from spring clamp (31).

NOTE

It is recommended that the next step be performed by two personnel. One person controls the chain lift while the other guides the engine out of the engine component.

16. Attach a chain lift through the top of the heater engine compartment to the engine lifting cable (32) located on the inboard side of the engine.
17. Carefully lift the engine slightly and guide to the right while continuing to remove engine from the engine compartment. Take care not to snag any of the fuel hoses or wires. Remove the engine from the heater and place on a rugged work surface next to the new diesel engine.

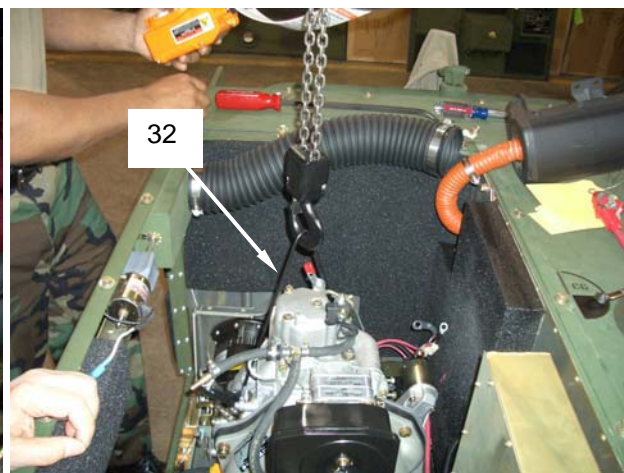
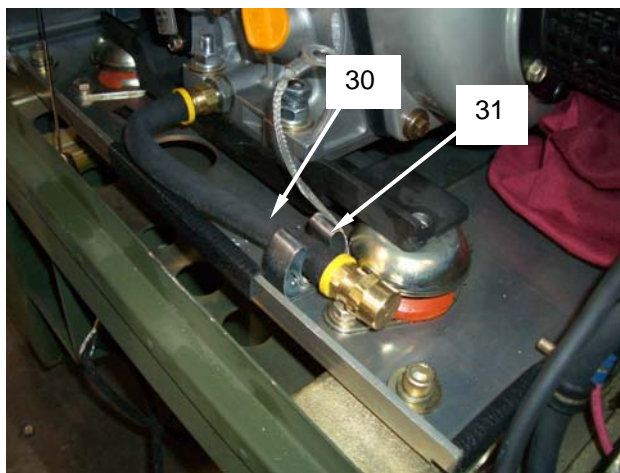
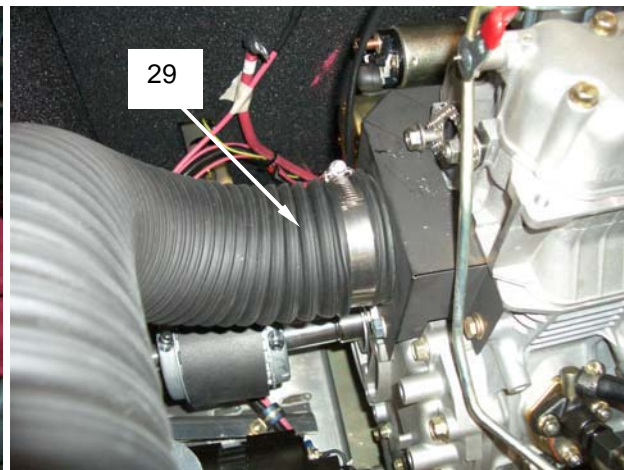
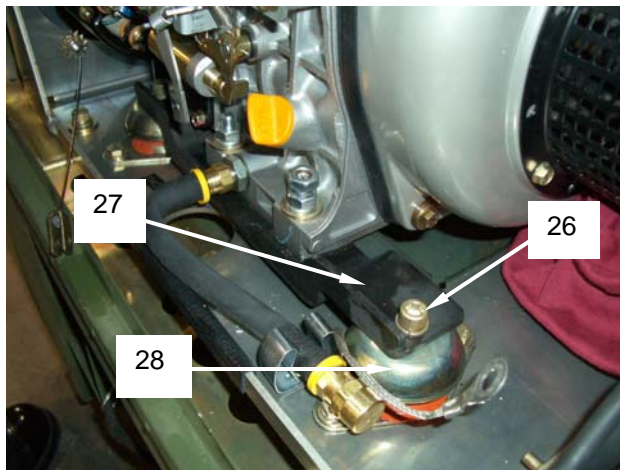

18. Loosen upper clamp and remove fuel line (33) attached to fitting behind the fuel injector (34).
19. Remove fuel hose (35) from injector pump fitting.
20. Loosen set screw (36) on pump drive coupling (37) three turns only. Do not remove set screw from pump drive coupling.
21. Remove nuts and lock washers (38) on either side of burner fuel pump (39) that secure it to the engine flywheel cover (40).

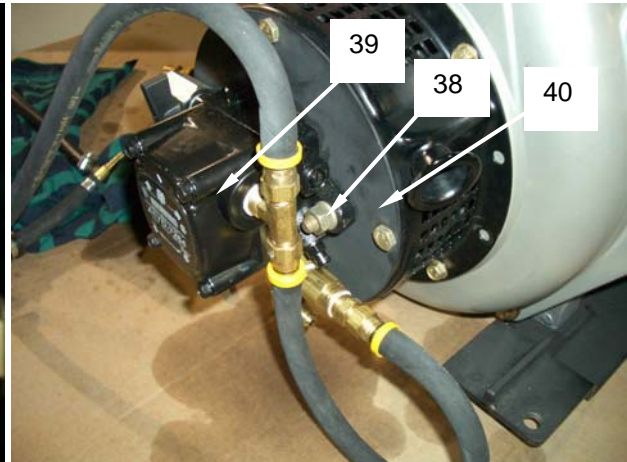
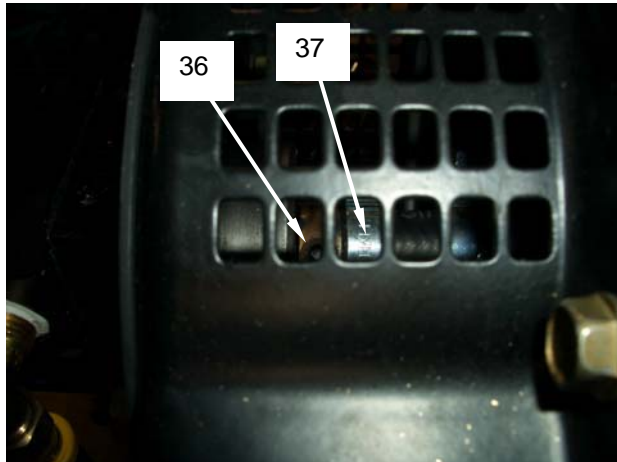
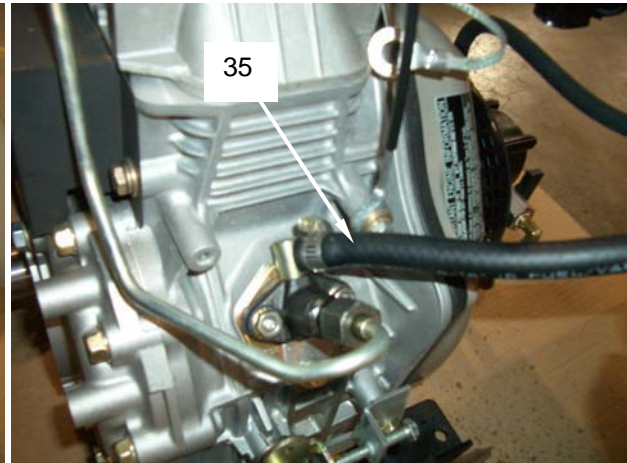
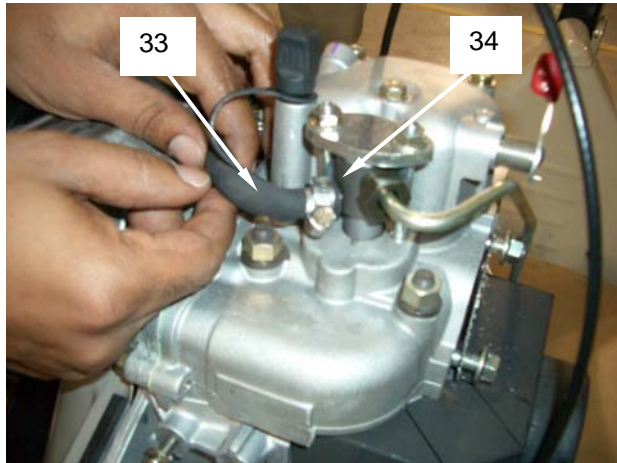

22. Slide burner fuel pump (39) and connected fuel hoses from pump drive coupling (37) and set aside.
23. Remove four bolts (41) securing engine flywheel cover (40) and remove.
24. Align one of the large holes (42) in the flywheel (43) with the matching hole in the engine block. Insert a long screwdriver into both holes to prevent the flywheel from turning during the next step.

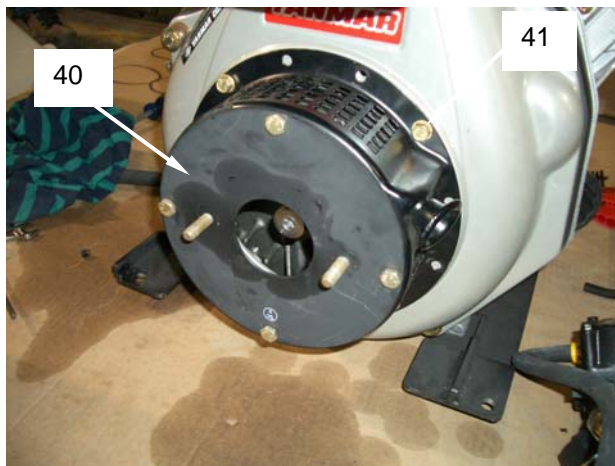
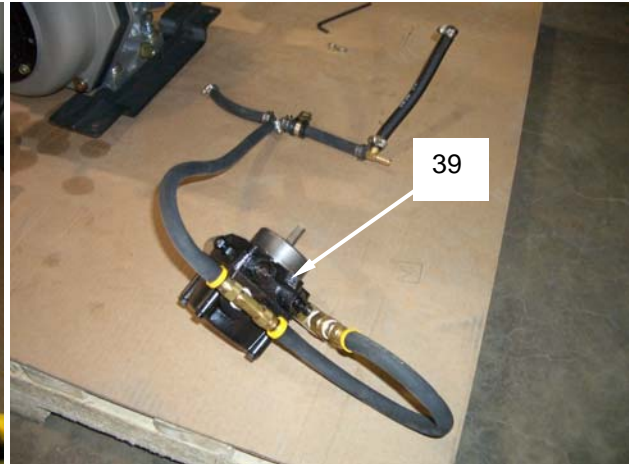
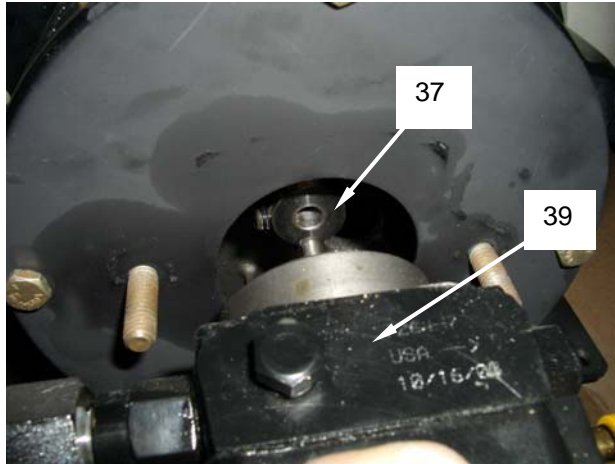

25. Remove three bolts (44) securing pump drive coupling (37) and remove coupling from engine drive shaft. Set coupling aside. Remove long screwdriver used to lock flywheel.

NOTE

Make a mark on the engine shaft to the right of the flexible coupling flange before performing the next step. After removing the flexible coupling flange in the next steps, measure and take note of how far the flexible coupling flange extends onto the shaft. This is done so that flexible coupling flange can be installed on the new diesel engine in the same position.

26. Loosen socket head screw (45) on flexible coupling flange (46). Place a flat blade screwdriver (47) in gap on coupling flange and tap into place so as to loosen the coupler grip on the engine shaft (48).
27. Slide the coupling flange (46) and rubber coupling (49) off engine drive shaft. Leave the screwdriver (47) tapped into the coupling flange (46) in place. Set flange and rubber coupling aside.
28. With the diesel engine positioned on the work surface, prop up using 2 – 2 x 4 inch sections of lumber (or equivalent) and remove the four bolts (50) that secure the two mounting brackets (51) to the base of the engine. Remove the brackets and attaching hardware and set aside.

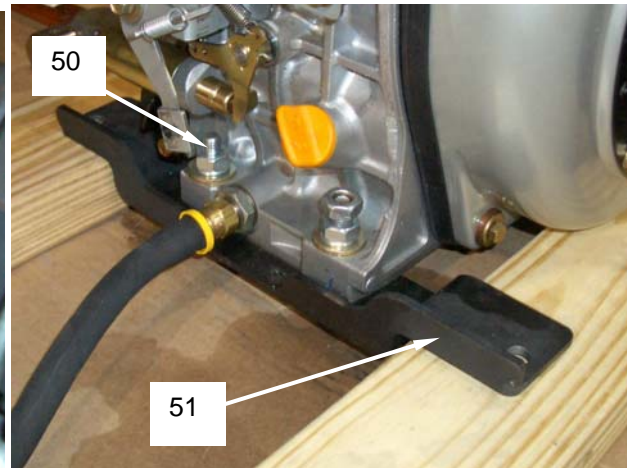
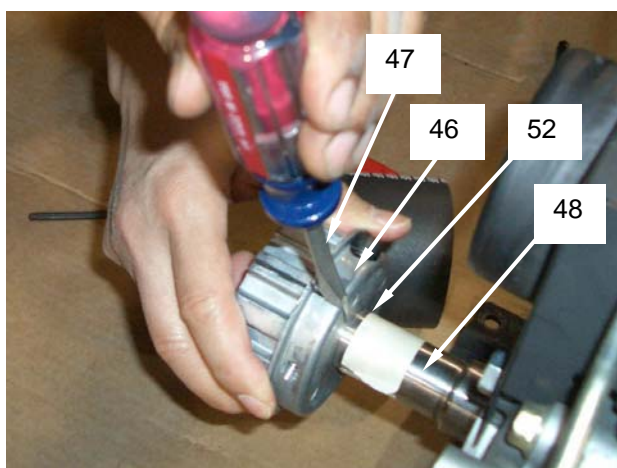
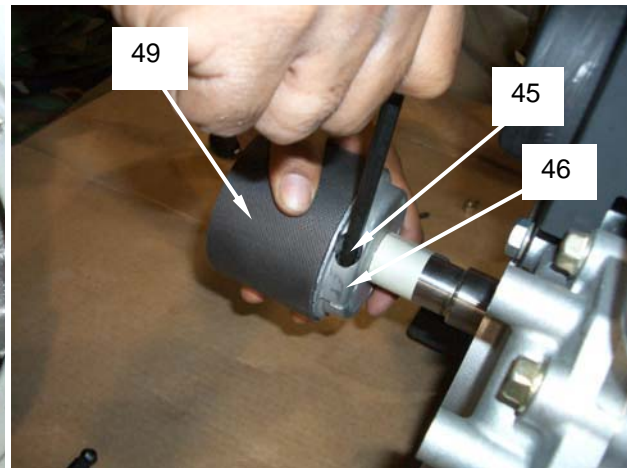

NOTE

The following steps are performed on the new replacement diesel engine.

29. With the new diesel engine positioned on the work surface, prop up using 2 – 2 x 4 inch sections of lumber (or equivalent) and install the four bolts (50) that secure the two mounting brackets (51) on to the base of the engine.
30. Align the key (52) on the shaft (48) with the slot in the coupling flange and slide the coupling flange (46) (with screwdriver tapped into slot) on the drive shaft of the engine to the dimensions noted prior to removal from the defective engine. Install the rubber coupling (49). Tighten the socket head screw (45) on the coupling flange to a torque of 264 to 300 inch-pounds.
31. Remove four bolts (41) securing engine flywheel cover (40) of new engine and remove.
32. Align the large hole (42) in the flywheel (43) with the matching hole in the engine block. Insert a long screwdriver into both holes to prevent the flywheel from turning during the next step.
33. Install burner fuel pump coupling (37) with the three bolts (44) set aside earlier. Tighten securely.
34. Install flywheel cover (4) with four bolts (41) removed earlier.



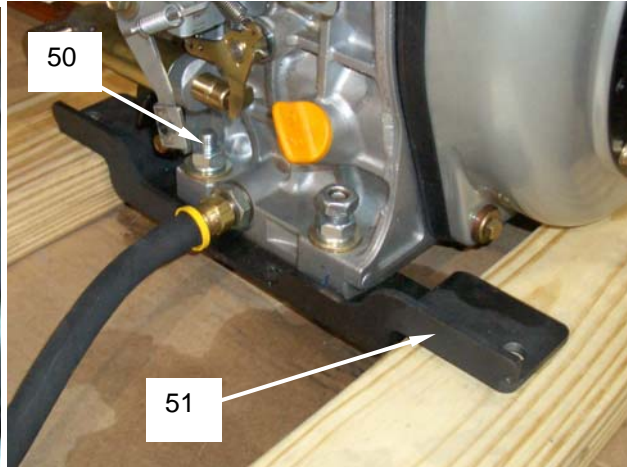
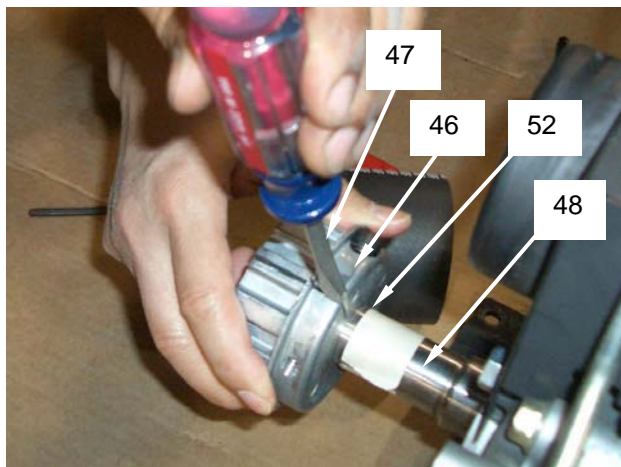
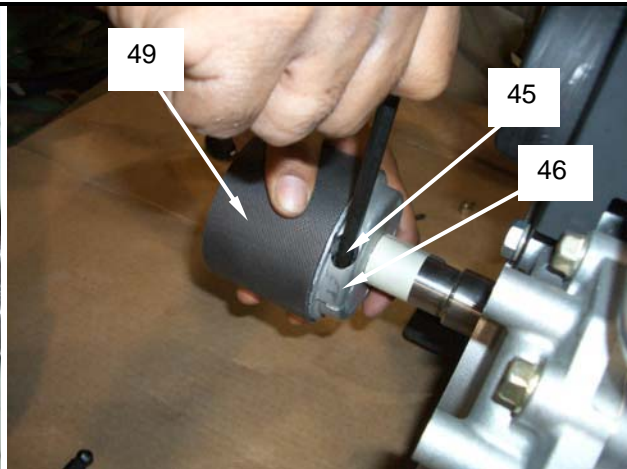
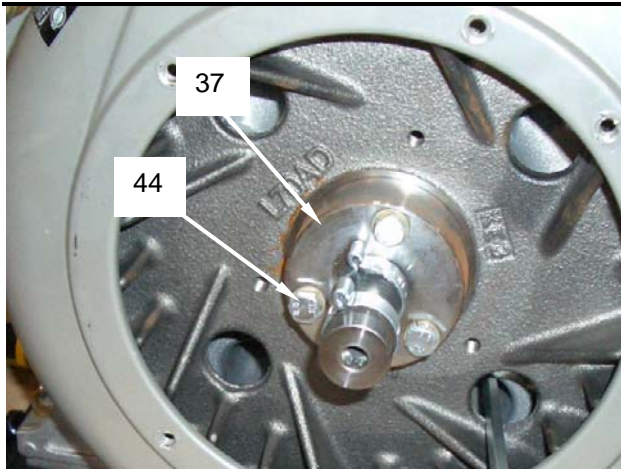

35. Rotate engine shaft with installed burner fuel pump coupling (37) so that set screw (36) on coupling is at the 9 o'clock position. Orient the flat portion of the burner fuel pump shaft to the 9 o'clock position.
36. Slide burner fuel pump shaft (53) into coupling (37) ensuring that the flat on the shaft aligns with the set screw (36) on coupling. Fully install burner fuel pump on flywheel cover studs.
37. Install nuts and lock washers (38) on either side of burner fuel pump (39) that secure it to the engine flywheel cover (40). Tighten securely.
38. Install fuel line (9) to fitting on fuel injector.
39. Install fuel hose (35) to injector pump fitting.
40. Install upper hose clamp (54) to engine block. Install fuel line (33) to fitting behind the fuel injector (34).

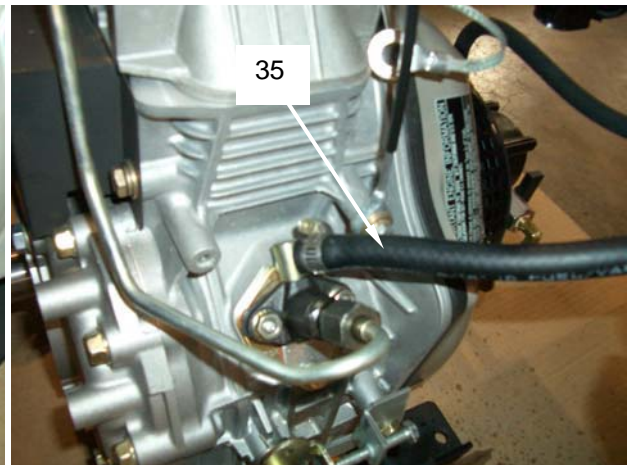
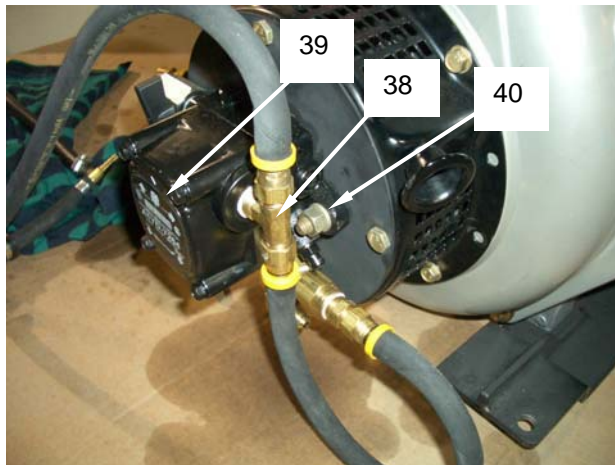
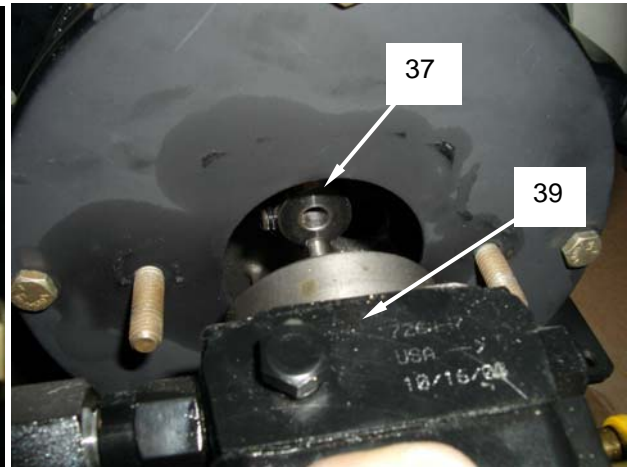
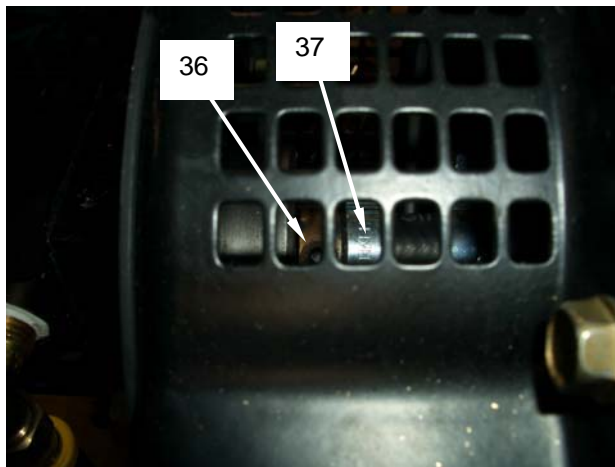

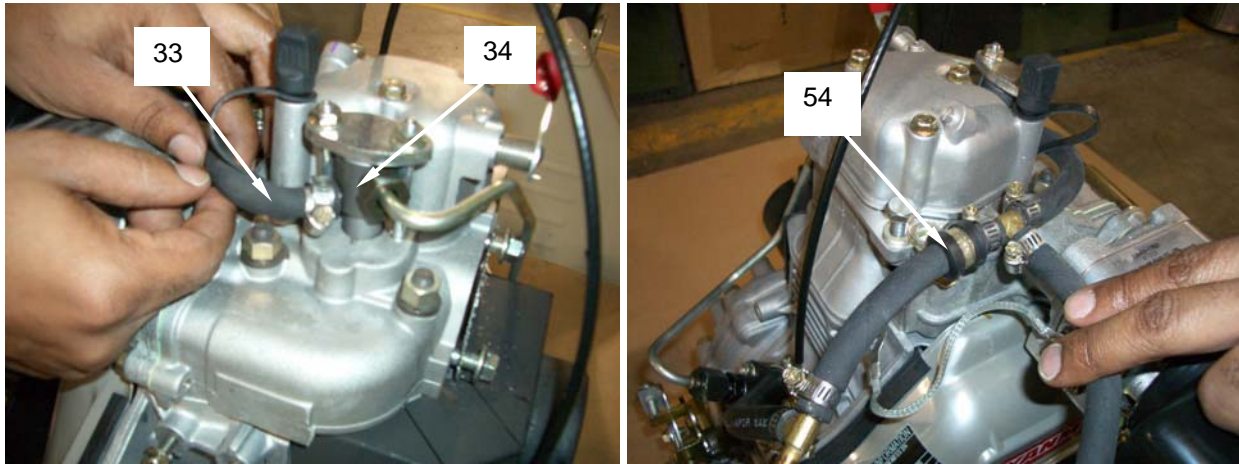

41. The new diesel engine has now been prepared for installation in the heater.
42. Attach the chain lift to the engine lifting cable **(32)** and raise the prepared new diesel engine off the work surface. Carefully lower into position into the engine compartment. Lower it toward the right side near the battery compartment and then toward the left to engage the rubber coupling **(49)** onto the coupling flange **(55)** from the inlet fan and alternator belt pulley. Do not fully install the engine on the coupling at this time.
43. Once the engine is positioned close enough but before easy access is lost, reinstall the engine sending unit wire **(5)**. Continue to completely engage the rubber coupling **(49)** and position the engine over the vibration mounts **(28)**. Ensure that the four mounting holes on the mounting brackets **(27)** align with the four vibration mounts. Install the four socket cap head bolts **(26)** removed earlier and secure the mounting bracket **(27)** to the vibration mounts **(28)**. Tighten securely.
44. Install engine oil filter drain hose **(30)** in spring clamp **(31)**.
45. Install air intake hose **(29)** on engine. Slide clamp into position and tighten securely.

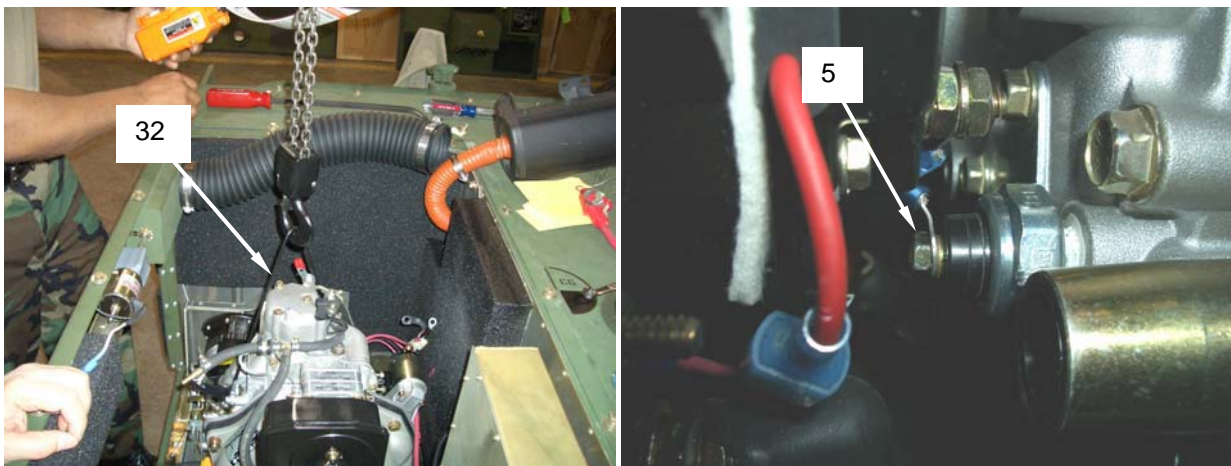

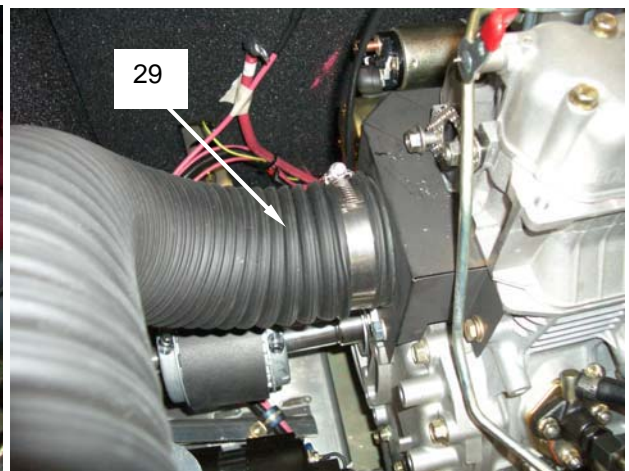
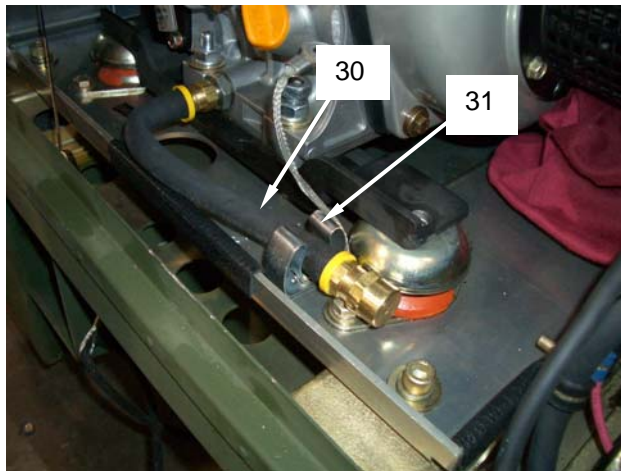
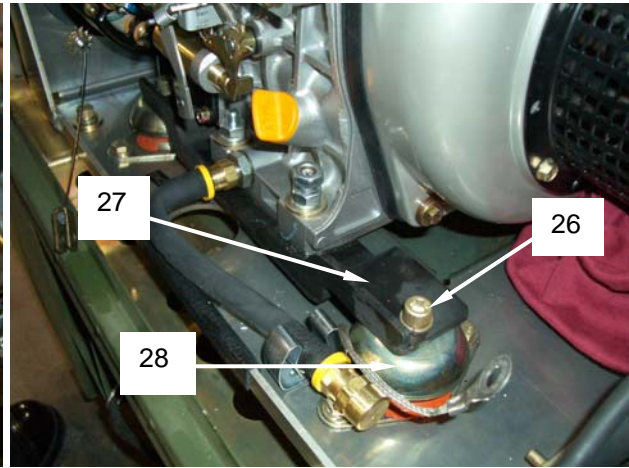
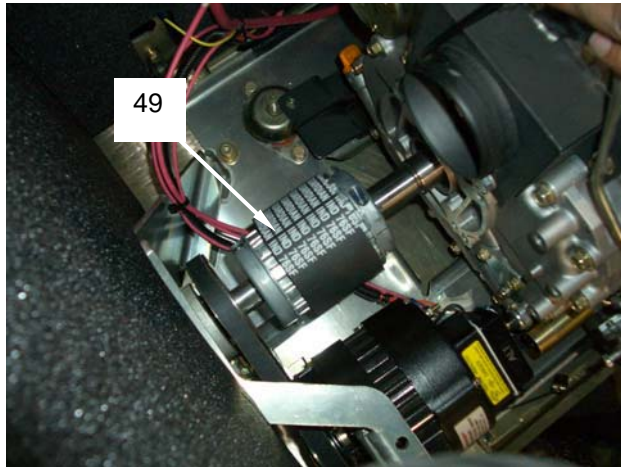

46. Reconnect fuel line (23) to fitting (24) located on underside of burner fuel pump (25).
47. Reconnect fuel line (22) connected to burner fuel pump shutoff valve (14).
48. Connect the cable (17) to the point labeled GP1 (18) on the side of the engine intake manifold. Tighten securely. Install the dust boot (56).
49. Install fuel hose (15) on tee connector (16).
50. Install black battery cable (20) and grounding strap (21) onto stud just below oil filler cap. Install hex nut (19) and washer. Tighten securely.
51. Install fuel line clamp (13) at midpoint of engine housing.
52. Open burner fuel pump shutoff valve (14).
53. Connect engine shutdown solenoid cable (10) by sliding retaining pin (12) into end of cable (10), engaging it with the throttle bracket on the front of the engine. Install new cotter pin (11) and spread blades.

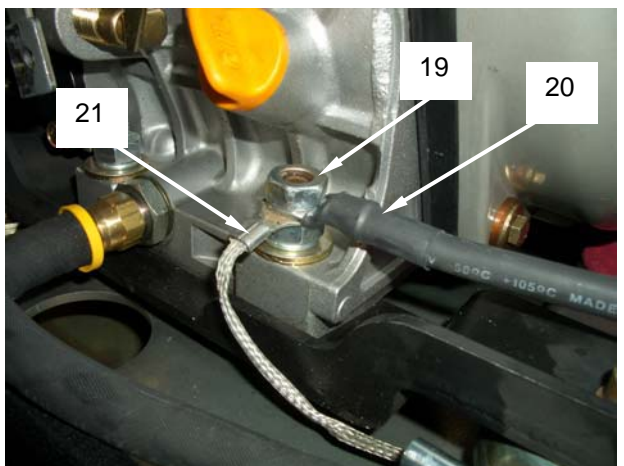
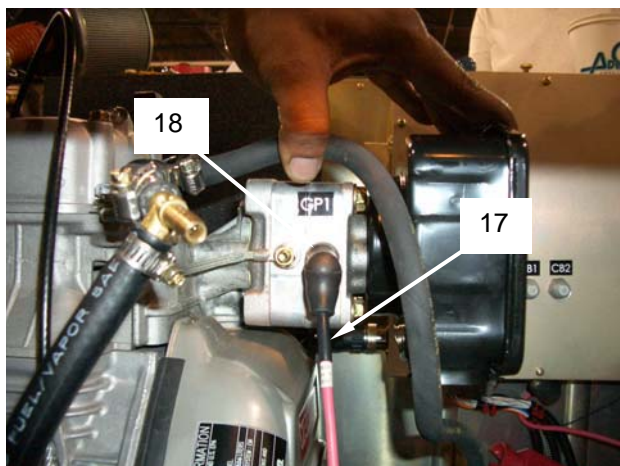
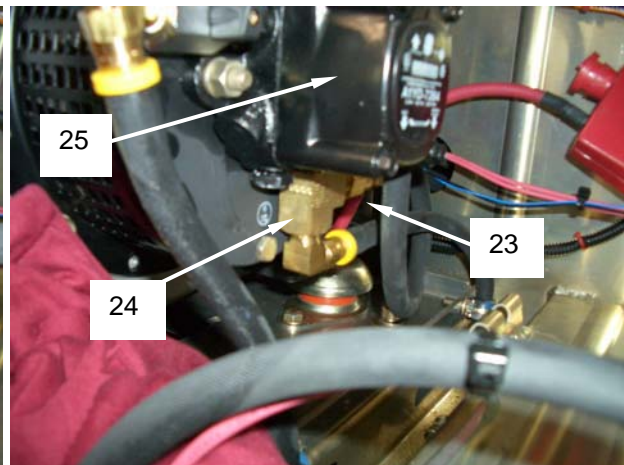
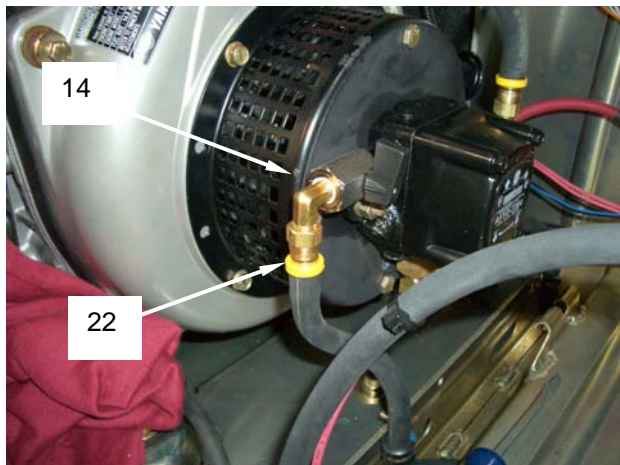

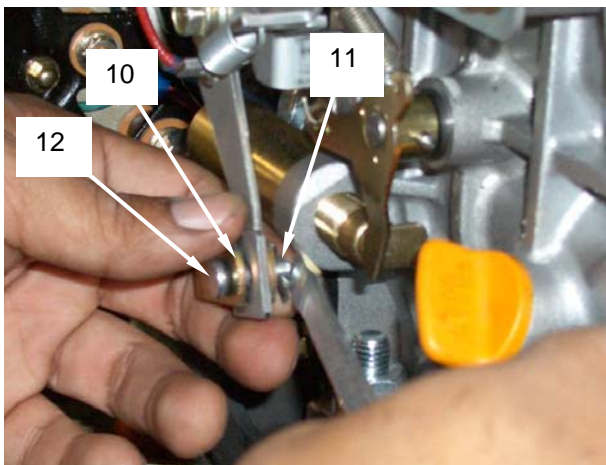
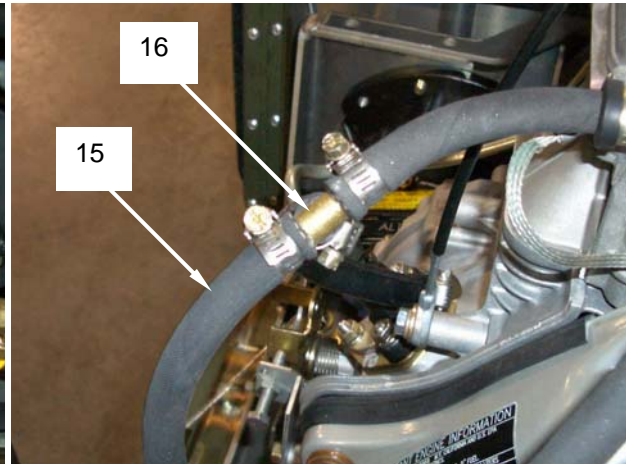
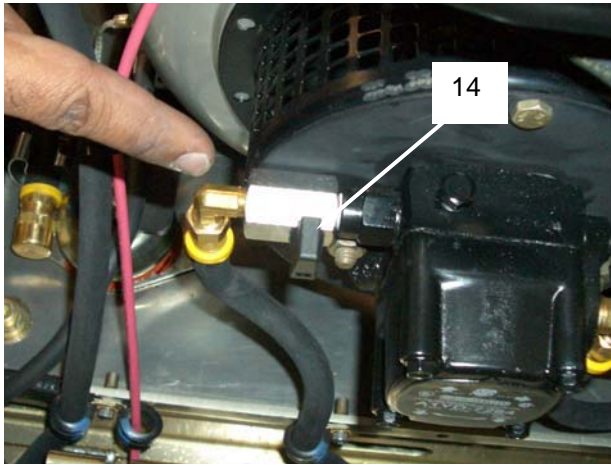

54. Connect all wires to starter (4) IAW markings and tags placed earlier.
55. Connect flexible exhaust tube (8) to the engine muffler (9). Install clamp (7) and tighten securely.
56. Install batteries (3) IAW WP 0058 00.
57. Ensure that new engine has the correct amount and type of lubricating oil IAW 0046 00.

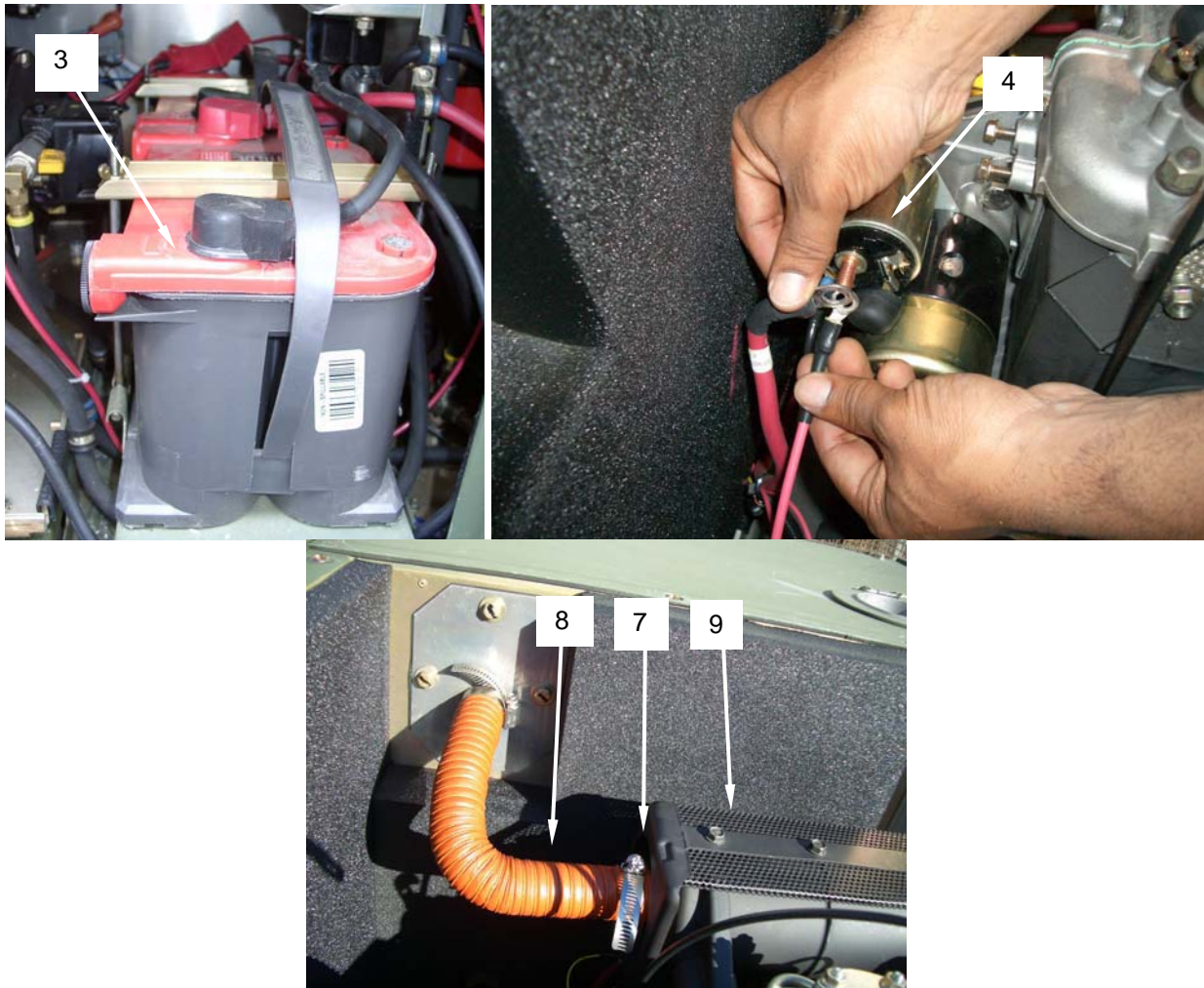

58. Install top engine compartment cover (1) by installing eighteen hex head bolts and lockwashers (2) set aside earlier.



END OF WORK PACKAGE

**FIELD (DIRECT) SUPPORT MAINTENANCE
LARGE CAPACITY FIELD HEATER (LCFH)
NSN 4520-01-500-1534
CYLINDER HEAD
REMOVE, SERVICE, INSPECT, INSTALL**

INITIAL SETUP:**Tools**

Tool Kit, General Mechanics (Item 2, WP 0092 00)
Wrench, Torque (Item 12, WP 0092 00 00)
Micrometer, Caliper (Item 13, WP 0092 00)

Personnel Required

MOS 63J or 52C

Materials/Parts

Oil, engine lubricating (Item 25, WP 0119 00)
Rag, wiping, clean (Item 4, WP 0119 00)
Solvent, degreasing (Item 24, WP 0119 00)

Equipment Condition

Heater shut down and cool.
Engine bay access door open.
Main battery switch OFF and handle removed.
Air cleaner removed (WP 0042 00)
Fuel injector removed (WP 0043 00)
Rocker arm assembly removed (WP 0076 00)

NOTE

Engine maintenance requires metric tools for the removal of all hardware and assemblies.

REMOVE

1. Remove muffler assembly from engine.
2. Release cylinder head **(1)** from studs **(6)** by removing nuts **(2, 3)** and washers **(4, 5)**. Carefully remove cylinder head from studs and place on a clean work surface.
3. Remove and discard O-ring **(7)** and cylinder head gasket **(8)**.
4. Slide exhaust valve **(16)** and inlet valve **(15)** out of cylinder head **(1)**.
5. Remove valve cap **(9)** and cotter assembly **(10)** from inlet valve **(15)**.

**WARNING**

Valve springs are under high pressure. Be sure to wear eye protection while working with valve springs. Use caution and remove spring retainers slowly. Failure to observe this warning can cause serious injury to personnel.

6. Compress spring **(12)** using compression tool and carefully remove spring retainer **(11)**. Slowly release hold on compression tool to release spring tension. Remove spring.
7. Remove valve stem seal **(13)** and washer **(14)** from inlet valve.
8. Repeat steps 4 through 6 for exhaust valve **(16)**.
9. Remove air intake pipe studs **(17)** from cylinder head **(1)** only if replacement is required.

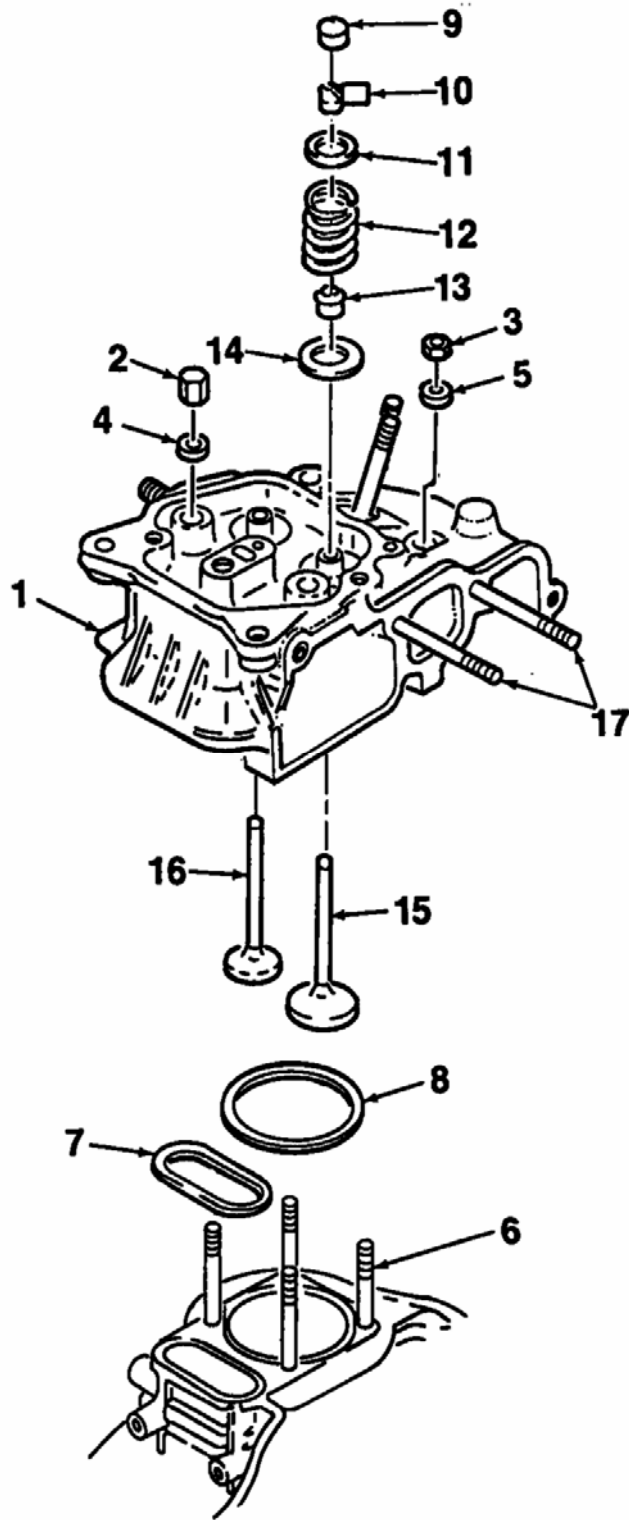

SERVICE

**WARNING**

Cleaning solvents are flammable and toxic to eye, skin, and respiratory tract. Skin and eye protections are required when working in contact with cleaning solvents. Avoid repeated or prolonged contact. Work in well ventilated area only. Keep away from heat, sparks, and open flame. Do not smoke while using cleaning solvent. Failure to observe this warning can result in injury or death to personnel.

1. Clean cylinder head components with cleaning solvent and a clean rag. Allow to air dry.
2. Remove carbon deposits from cylinder head (**1**) and valves (**15**, **16**) using a wire brush. Use care to prevent damage to surfaces.
3. Remove all old gasket material from crankcase and cylinder head mating surfaces.

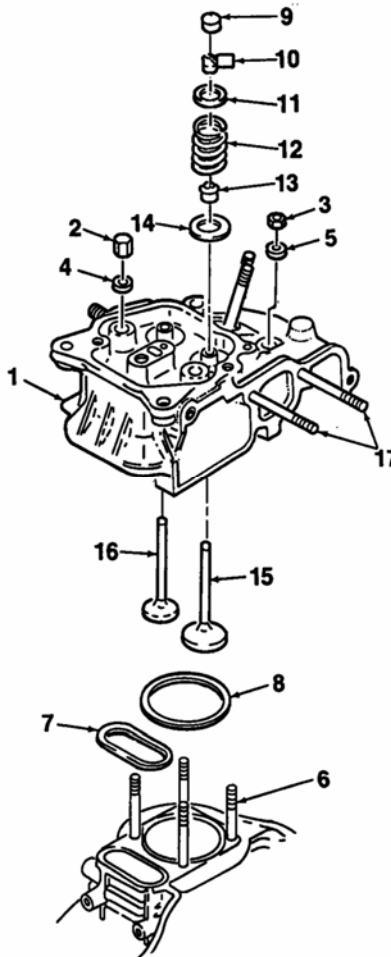

INSPECT

1. Inspect cylinder head **(1)** for cracks and deformation. Replace cylinder head if damaged or deformed in any manner
2. Inspect stems of valves **(15, 16)** for wear or distortion. Measure the outside diameter (OD) of the stems as shown. OD shall be 0.2323 inch (5.90 mm), minimum. Replace valve if stem is out of limits.
3. Measure the internal diameter (ID) of the valve guides (installed in cylinder head). ID shall be 0.2394 inch (6.08 mm), maximum. Replace cylinder head **(1)** if valve guide ID is out of limits.
4. Inspect valve springs **(12)** for cracks, broken sections, or deformation. Replace spring if damaged or deformed in any way.
5. Measure free length (non-compressed) of valve springs as shown. Length must be 1.240 inch (31.5 mm), minimum. Replace valve spring if less than required length.
6. Insert valves **(15, 16)** into cylinder head **(1)**. Measure valve sinkage as shown. Sinkage shall be 0.043 inch (1.1 mm), maximum. If sinkage exceeds limit, discard valves.

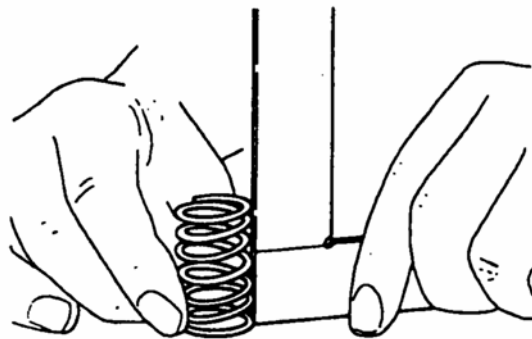
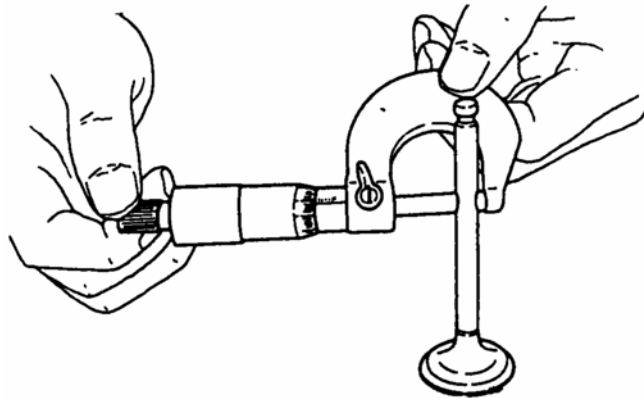

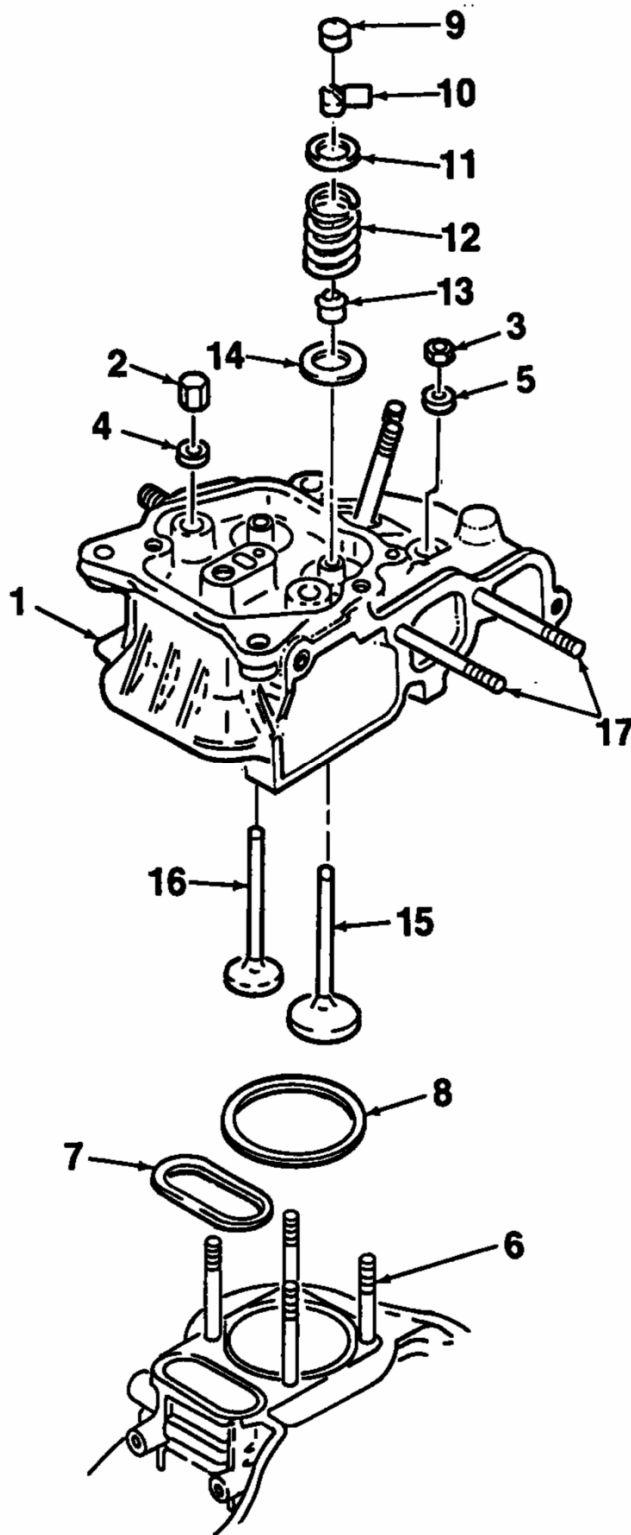

INSTALL

1. Install air intake pipe studs **(17)** into cylinder head **(1)**.
2. Lubricate the stems of exhaust valve **(16)** and inlet valve **(15)** with a light coat of lubricating oil. Slide valves into cylinder head **(1)**.
3. Install valve stem seal **(13)** and washer **(14)** onto inlet valve **(15)**.
4. Install and compress valve spring **(12)** using compression tool. Carefully install spring retainer **(11)**. Slowly release hold on compression tool to release spring tension.
5. Install cotter assembly **(10)** and valve cap **(9)**.
6. Repeat steps 3 through 5 for exhaust valve **(16)**.
7. Mate new O-ring **(7)** and cylinder head gasket **(8)** to crankcase.
8. Carefully slide cylinder head **(1)** over studs **(6)** and mate to crankcase.
- 9. Install nuts **(2, 3)** and washers **(4, 5)**. Torque nuts in a criss-cross pattern to 365 to 399 inch-pounds (420 to 460 kg-cm). Tighten a second time to ensure a snug fit of cylinder head to crankcase.
10. Install air cleaner (WP 0042 00).
11. Install fuel injector (WP 0043 00).
12. Install rocker arm assembly (WP 0076 00)

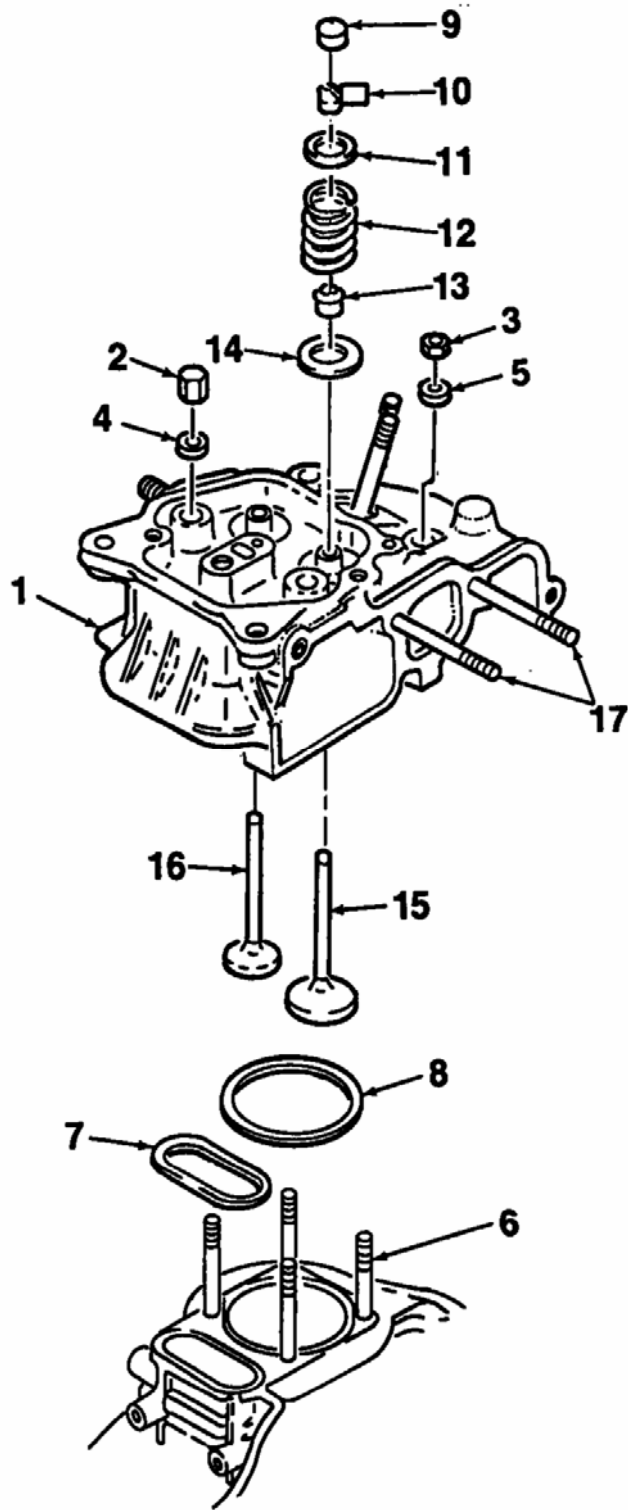

END OF WORK PACKAGE

0079 00-7/(8 Blank)

Change 1

CHAPTER 9
SUSTAINMENT (GENERAL) SUPPORT TROUBLESHOOTING
LARGE CAPACITY FIELD HEATER (LCFH)

**SUSTAINMENT (GENERAL) SUPPORT MAINTENANCE
LARGE CAPACITY FIELD HEATER (LCFH)
MALFUNCTION SYMPTOM INDEX**

GENERAL

This chapter provides information to permit the operator to troubleshoot some problems that may occur during the operation of the LCFH.

MALFUNCTION SYMPTOM INDEX

The malfunction symptom index lists common malfunctions that may occur during the operation of the Large Capacity Field Heater. Find the malfunction to be eliminated and go to the indicated troubleshooting table in work package 0081 00.

This index cannot list all malfunctions that may occur, all tests or inspections needed to find the fault, or all actions required to correct the fault. If the existing malfunction is not listed, or cannot be corrected through this troubleshooting index, notify your supervisor.

Prior to using the malfunction symptom index, be sure you have performed all normal operational checks.

The troubleshooting procedures referenced below assume that electrical wires are undamaged and wiring harnesses are operable. Conduct continuity checks on suspect wiring / harnesses as required prior to performing troubleshooting procedures.

Malfunction	Troubleshooting Step
Engine will not start	1
Engine starts and stops.....	2
Engine output drops	3
Engine runs rough.....	4
Low compression pressure	5
Engine emits white smoke	6
Engine emits black smoke	7

**SUSTAINMENT (GENERAL) SUPPORT MAINTENANCE
LARGE CAPACITY FIELD HEATER (LCFH)
TROUBLESHOOTING PROCEDURES**

INITIAL SETUP:

Tools

Tool Kit, General Mechanics (Item 2, WP 0092 00)
Wrench, Torque (Item 20, WP 0092 00)

Personnel Required

MOS 63J or 52C

Materials/Parts

None required

Equipment Condition

Heater shut down and cool unless otherwise indicated.
Main battery switch OFF and handle removed.

Table 1. Troubleshooting Procedure for Large Capacity Field Heater (LCFH).

MALFUNCTION	TEST OR INSPECTION	CORRECTIVE ACTION
1. ENGINE WILL NOT START	Step 1. Check for defective injection pump delivery valve (WP 0085 00).	Step 1. Remove and replace pump delivery valve (WP 0086 00). Step 2. If engine cannot be repaired, replace IAW WP 0078 00.
2. ENGINE STARTS AND STOPS	Step 1. Check for defective injection pump delivery valve (WP 0085 00). Step 2. Possible crankshaft bearing seizure. Grasp flywheel and attempt to manually rotate engine in clockwise direction to check for seizure. Step 3. Possible piston liner seizure. Grasp flywheel and attempt to manually rotate engine in clockwise direction to check for seizure.	Step 1. Remove and replace pump delivery valve (WP 0086 00). Step 2. Remove and replace crankshaft bearing (WP 0085 00). Step 3. Remove and replace piston components (WP 0088 00). Step 4. If engine cannot be repaired, replace IAW WP 0078 00.
3. ENGINE OUTPUT DROPS	Step 1. Check for defective injection pump delivery valve (WP 0085 00). Step 2. Check for carbon deposits in the engine combustion chamber (WP 0084 00).	Step 1. Remove and replace pump delivery valve (WP 0086 00). Step 2. Clean carbon from engine combustion chamber (WP 0080 00). Step 3. Remove and replace

Table 1. Troubleshooting Procedure for Large Capacity Field Heater (LCFH).

MALFUNCTION	TEST OR INSPECTION	CORRECTIVE ACTION
4. ENGINE RUNS ROUGH	<p>Step 3. Possible piston seizure or wear. Inspect pistons (WP 0087 00).</p> <p>Step 1. Check flywheel nut for proper tightness.</p>	<p>damaged or worn piston components. (WP 0088 00).</p> <p>Step 4. If engine cannot be repaired, replace IAW WP 0078 00.</p> <p>Step 1. Tighten flywheel nut to 87 to 94 foot-pounds (1200 to 1300 kg-cm).</p> <p>Step 2. If engine cannot be repaired, replace IAW WP 0078 00.</p>
5. LOW COMPRESSION PRESSURE	<p>Step 1. Check for leak at inlet and exhaust valves indicating worn valve seat or guide (WP 0085 00).</p> <p>Step 2. Check for loose cylinder head nuts causing leak at cylinder head gasket.</p> <p>Step 3. Check for broken or damaged cylinder head gasket (WP 0084 00).</p>	<p>Step 1. Remove and replace inlet / exhaust valve components as required (WP 0086 00).</p> <p>Step 2. Tighten cylinder head nuts in an even pattern to 365 to 399 inch-pounds (420 to 460 kg-cm).</p> <p>Step 3. Remove and replace cylinder head gasket (WP 0080 00).</p> <p>Step 4. If engine cannot be repaired, replace IAW WP 0078 00.</p>
6. ENGINE EMITS WHITE SMOKE	<p>Step 1. Possible worn or broken piston ring, worn piston. Inspect piston assembly (WP 0087 00).</p> <p>Step 2. Check for defective valve stem seal (WP 0087 00).</p>	<p>Step 1. Remove and replace damaged piston assembly components (WP 0088 00).</p> <p>Step 2. Remove and replace valve stem seal (WP 0088 00).</p> <p>Step 3. If engine cannot be repaired, replace IAW WP 0078 00.</p>

Table 1. Troubleshooting Procedure for Large Capacity Field Heater (LCFH).

MALFUNCTION	TEST OR INSPECTION	CORRECTIVE ACTION
7. ENGINE EMITS BLACK SMOKE	Step 1. Possible piston / cylinder liner seizure. Inspect for seized components (WP 0087 00).	Step 1. Remove and replace damaged piston assembly components (WP 0088 00). Step 2. If engine cannot be repaired, replace IAW WP 0078 00.

CHAPTER 10

SUSTAINMENT (GENERAL) SUPPORT MAINTENANCE

LARGE CAPACITY FIELD HEATER (LCFH)

**SUSTAINMENT (GENERAL) SUPPORT MAINTENANCE
LARGE CAPACITY FIELD HEATER (LCFH)
GENERAL SUPPORT MAINTENANCE INTRODUCTION**

INTRODUCTION TO GENERAL SUPPORT MAINTENANCE

This section contains General Support Maintenance applicable to the Large Capacity Field Heater as authorized by the Maintenance Allocation Chart (MAC), Work Package 0092 00, of this manual. General Support Maintenance personnel may also perform all functions allocated in Operator, Unit, and Direct Support Maintenance.

All maintenance procedures in this section can be performed by one person unless otherwise indicated. Read all **WARNINGS, CAUTIONS, NOTES**, and instructions carefully before attempting any procedures. Read and understand all warnings at the front of this manual.

Each maintenance action will include a heading which lists the actions to be taken, the tools and parts/materials required, and the condition in which the equipment must be in to perform the action.

All General Support maintenance instructions covered in this section are unique to the Large Capacity Field Heater.

**SUSTAINMENT (GENERAL) SUPPORT MAINTENANCE
LARGE CAPACITY FIELD HEATER (LCFH)
NSN 4520-01-500-1534
BALANCER SHAFT
REMOVE, SERVICE, INSPECT, INSTALL**

INITIAL SETUP:**Tools**

Tool Kit, General Mechanics (Item 2, WP 0092 00)
Wrench, Torque (Item 12, WP 0092 00)

Personnel Required

MOS 63J or 52C

Materials/Parts

Oil, engine lubricating (Item 25, WP 0119 00)
Rag, wiping, clean (Item 4, WP 0119 00)
Solvent, degreasing (Item 24, WP 0119 00)
Grease, high temperature (Item 22, WP 0119 00)

Equipment Condition

Heater shut down and cool.
Engine bay access door open.
Main battery switch OFF and handle removed.
Engine oil drained (WP 0046 00).

NOTE

Engine maintenance requires metric tools for the removal of all hardware and assemblies.

REMOVE**CAUTION**

When removing crankcase cover, be careful not to damage oil seal.

1. Release crankcase cover **(1)** from cylinder block **(8)** by removing fifteen screws **(2)**. Carefully pry crankcase cover from engine crankcase.
2. Remove cover gasket **(3)**. Discard if damaged or deformed.
3. Carefully remove assembled balancer shaft **(5)** and gear **(7)** from cylinder block **(8)**.
4. Remove bearing **(4)** from crankcase cover **(1)** and bearing **(6)** from cylinder block **(8)** only if replacement is required.

SERVICE**WARNING**

Cleaning solvents are flammable and toxic to eye, skin, and respiratory tract. Skin and eye protection are required when working in contact with cleaning solvents. Avoid repeated or prolonged contact. Work in well ventilated area only. Keep away from heat, sparks, and open flame. Do not smoke while using cleaning solvent. Failure to observe this warning can result in injury or death to personnel.

Clean components with cleaning solvent and a clean rag. Allow to air dry.

INSPECT

1. Inspect crankcase cover **(1)** for cracks, deformation, or obvious damage. Inspect mating surfaces for scratches, burrs, or blemishes. Replace cover if damaged.
2. Inspect cover gasket **(3)** for damage or deformation. Replace if damaged in any way.
3. Inspect gear **(7)** for broken, chipped, or worn teeth. Replace gear and camshaft **(5)** as an assembly if gear is damaged or worn.
4. Inspect balancer shaft for signs of unusual or uneven wear. Check for obvious damage. Replace if any damage or excessive wear is suspected.

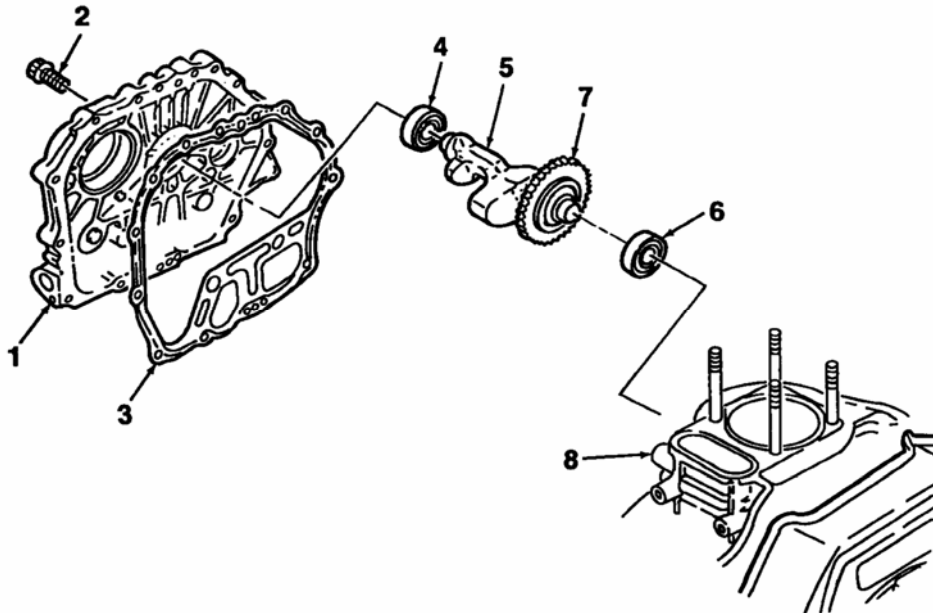



INSTALL

1. If removed, install bearings **(4, 6)**.
2. Carefully insert assembled balancer shaft **(5)** and gear **(7)** into cylinder block **(8)**. Align match-marks **(9)** on balancer gear and crankshaft gear, then press balancer shaft **(5)** into bearing **(6)**.
3. Apply grease to lips of crankshaft oil seal (located in crankcase cover **(1)**).
4. Apply oil to crankshaft and camshaft. Make sure that oil pump drive gears are properly engaged.
5. Mate cover gasket **(3)** to cylinder block **(8)**.
6. Mate crankcase cover **(1)** to cylinder block **(8)** and secure using fifteen screws **(2)**. Tighten screws in criss-cross sequence as shown. Torque all screws to 174 to 199 inch-pounds (200 to 230 kg-cm). ■
7. Service engine oil (WP 0046 00).

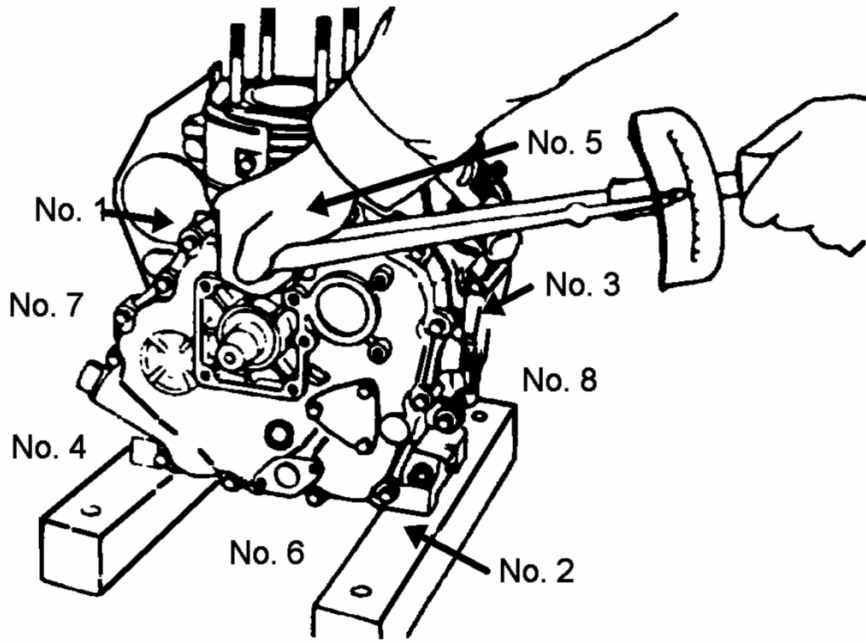
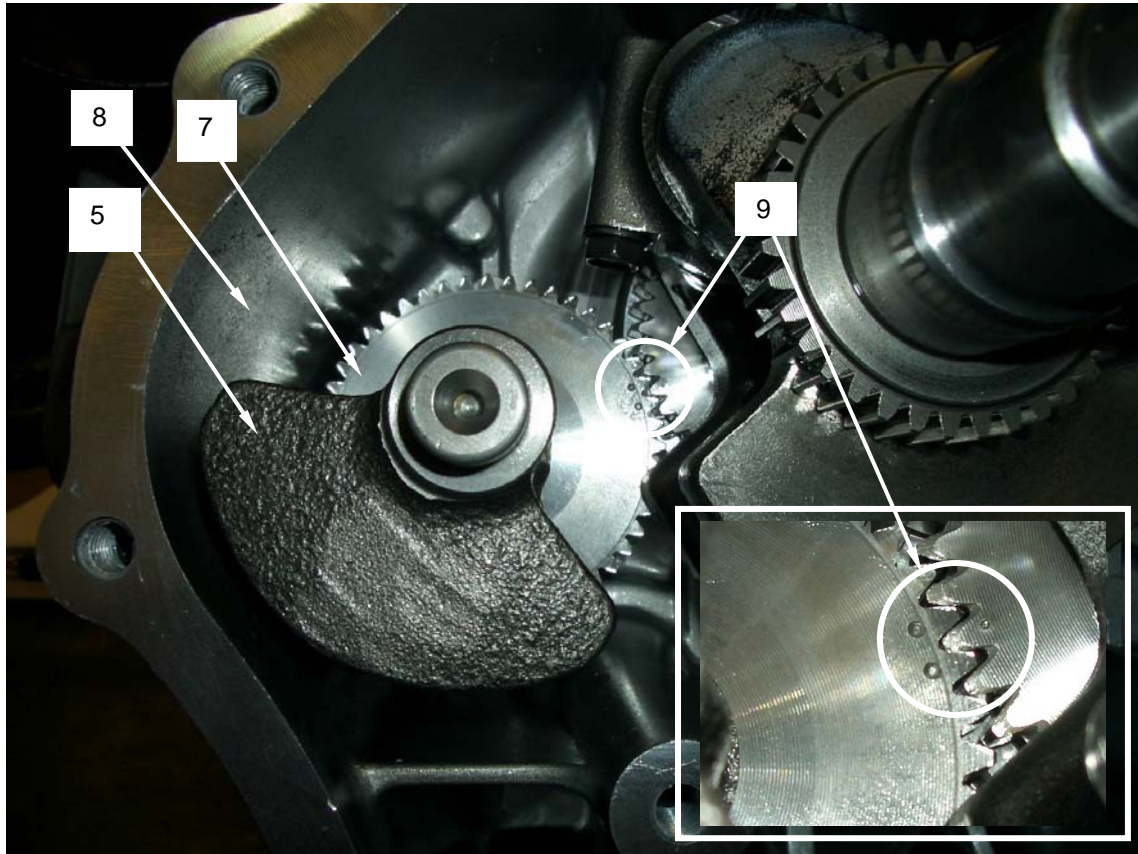

END OF WORK PACKAGE

Change 1

0083 00-4

**SUSTAINMENT (GENERAL) SUPPORT MAINTENANCE
LARGE CAPACITY FIELD HEATER (LCFH)
NSN 4520-01-500-1534
CAMSHAFT ASSEMBLY
REMOVE, SERVICE, INSPECT, INSTALL**

INITIAL SETUP:**Tools**

Tool Kit, General Mechanics (Item 2, WP 0092 00)
Wrench, Torque (Item 12, WP 0092 00)
Micrometer, Caliper (Item 13, WP 0092 00)

Personnel Required

MOS 63J or 52C

Materials/Parts

Oil, engine lubricating (Item 25, WP 0119 00)
Rag, wiping (Item 4, WP 0119 00)
Solvent, degreasing (Item 24, WP 0119 00)
Grease, high temperature (Item 22, WP 0119 00)

Equipment Condition

Heater shut down and cool.
Engine bay access door open.
Main battery switch OFF and handle removed.
Engine oil drained (WP 0046 00)
Fuel injection pump removed (WP 0074 00)

NOTE

Engine maintenance requires metric tools for the removal of all hardware and assemblies.

REMOVAL**CAUTION**

When removing crankcase cover, be careful not to damage oil seal.

1. Release crankcase cover **(1)** from cylinder block by removing fifteen screws **(2)**. Carefully pry crankcase cover from engine crankcase.
2. Remove cover gasket **(3)**. Discard if damaged or deformed.

NOTE

Exhaust and intake tappets **(6, 7)** may fall down when pulling out camshaft assembly. Keep tappets separate to avoid confusion.

3. Remove valve cover **(11)** by removing three bolts **(12)**.
4. Remove rocker arm assembly by removing two bolts **(13)** retaining rocker arm support **(14)**. Carefully place rocker arm assembly and hardware aside.
5. Remove push rods **(8, 9)** and set aside.
6. Lay engine on side and push lifter out of the way.
7. Carefully remove assembled camshaft components from cylinder block.
8. Remove bearing **(4)** from crankcase cover **(1)** only if replacement is required.

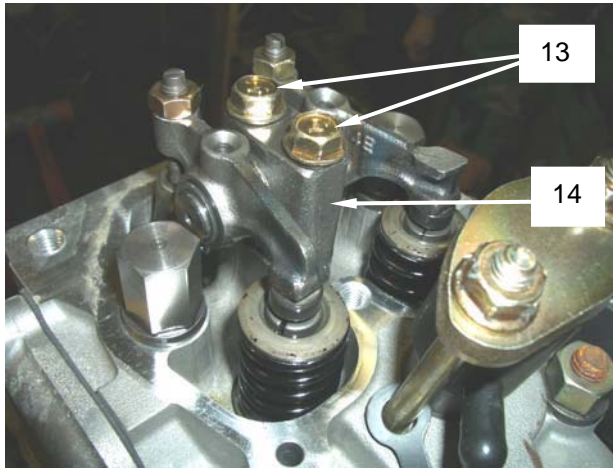
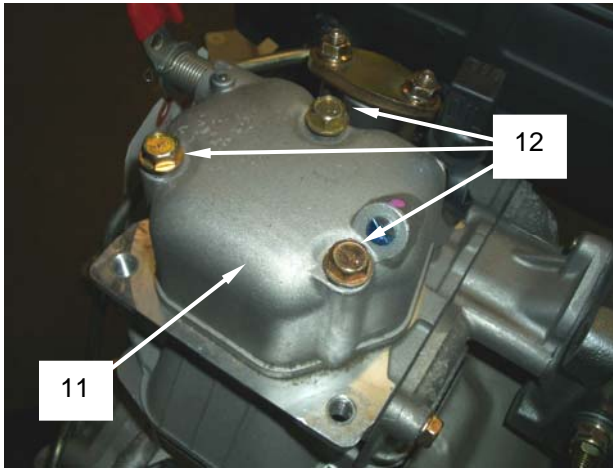
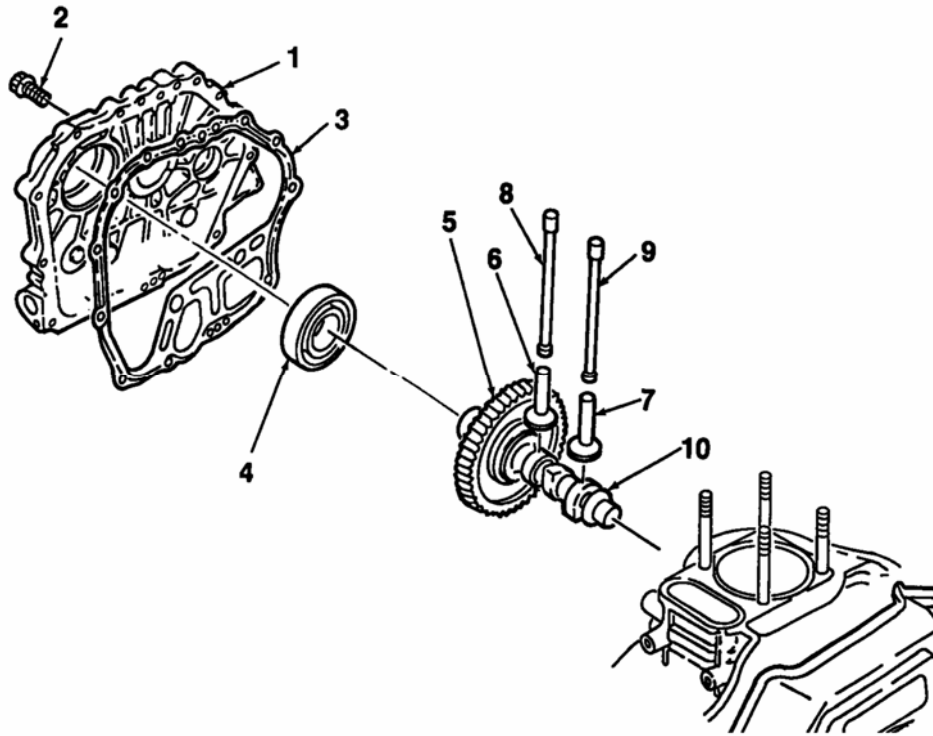

SERVICE**WARNING**

Cleaning solvents are flammable and toxic to eye, skin, and respiratory tract. Skin and eye protection are required when working in contact with cleaning solvents. Avoid repeated or prolonged contact. Work in well ventilated area only. Keep away from heat, sparks, and open flame. Do not smoke while using cleaning solvent. Failure to observe this warning can result in injury or death to personnel.

Clean components with cleaning solvent and a clean rag. Allow to air dry.

INSPECTION

1. Inspect crankcase cover **(1)** for cracks, deformation, or obvious damage. Inspect mating surfaces for scratches, burrs, or blemishes. Replace cover if damaged.
2. Inspect cover gasket **(3)** for damage or deformation. Replace if damaged in any way.
3. Inspect gear **(5)** for broken, chipped, or worn teeth. Replace gear and camshaft **(10)** as an assembly if gear is damaged or worn.
4. Inspect outer surfaces of tappets **(6, 7)** for wear or damage. Check condition of tappet contact point. Measure the outside diameter (OD) of tappet stems. OD must be 0.2705 inch (6.87 mm), minimum. Replace tappet if damaged, worn, or out of limits.
5. Measure the OD of camshaft **(10)** where it mates to crankcase cover bearing **(4)**. OD must be 1.1772 inches (29.90 mm), minimum. Replace camshaft **(10)** and gear **(5)** if out of limits.
6. Measure the OD of camshaft **(10)** on opposite end (where it mates to cylinder block needle bearing). OD must be 0.5874 inch (14.92 mm), minimum. Replace camshaft **(10)** and gear **(5)** if out of limits.
7. Measure the internal diameter (ID) of bearing **(4)**. ID must be 1.1808 inches (29.993 mm), maximum. Replace bearing if out of limits.

INSTALLATION

1. Lay engine on side and push lifter out of the way. Return engine to upright position.
2. Carefully insert assembled camshaft **(10)** and gear **(5)** into cylinder block. Align match-marks **(15)** on camshaft gear with those on crankshaft gear, then press camshaft **(10)** into crankcase needle bearing.
3. Insert tappets **(8, 9)** into cylinder block.
4. Install push rods **(8, 9)** removed earlier.
5. Install rocker arm assembly set aside earlier by installing two bolts **(13)** retaining rocker arm support **(14)**.
6. Install valve cover **(11)** by installing three bolts **(12)**.

INSTALL continued

7. Apply grease to lips of crankshaft oil seal (located in crankcase cover **(1)**).
8. Apply oil to crankshaft and camshaft. Make sure that oil pump drive gears are properly engaged.
9. Mate cover gasket **(3)** to cylinder block.
10. Mate crankcase cover **(1)** to cylinder block and secure using fifteen screws **(2)**. Tighten screws in criss-cross sequence as shown. Torque all screws to 174 to 199 inch-pounds (200 to 230 kg-cm).
11. Install fuel injection pump (WP 0074 00).
12. Service engine oil (WP 0046 00).

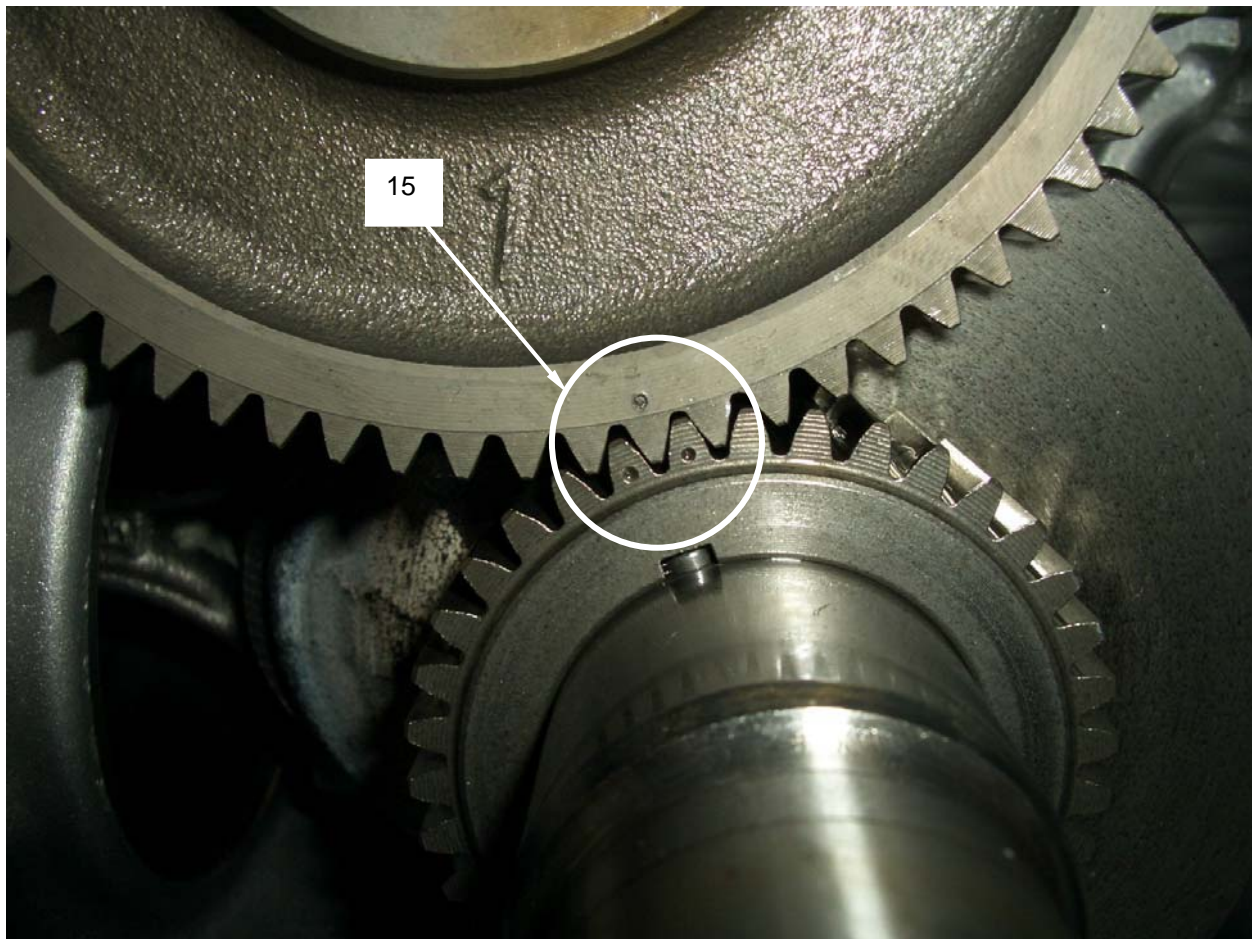

INSTALL continued

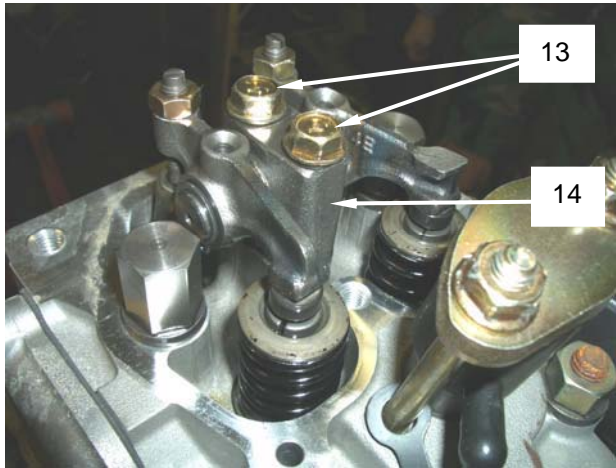
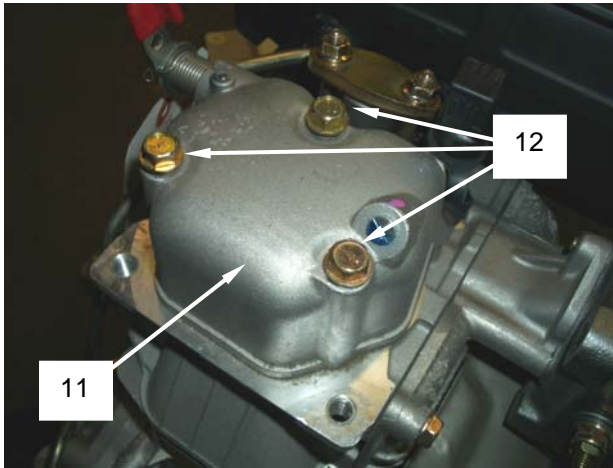
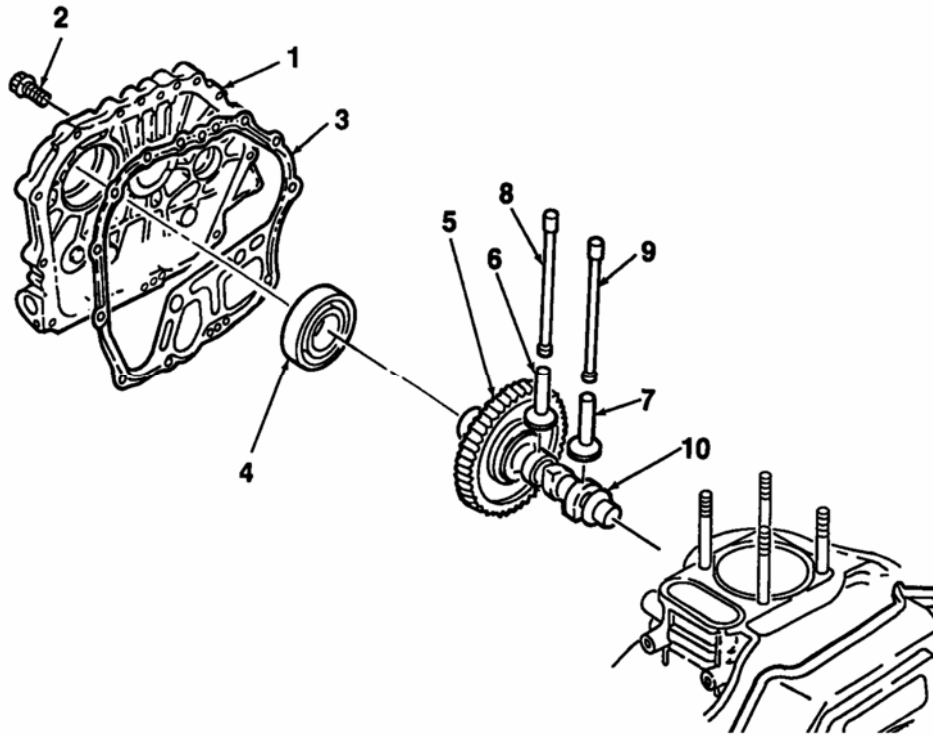

INSTALL continued

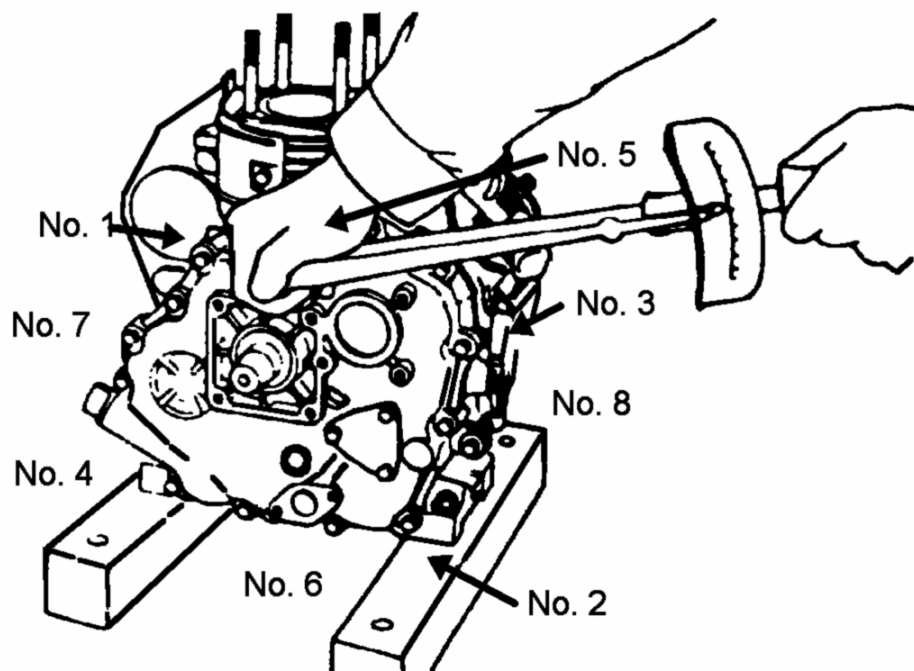

END OF WORK PACKAGE

**SUSTAINMENT (GENERAL) SUPPORT MAINTENANCE
LARGE CAPACITY FIELD HEATER (LCFH)
NSN 4520-01-500-1534
CRANKSHAFT ASSEMBLY
REMOVE, SERVICE, INSPECT, INSTALL**

INITIAL SETUP:**Tools**

Tool Kit, General Mechanics (Item 2, WP 0092 00)
Handle, Flywheel Locking (Item 5, WP 0092 00)
Remover, Flywheel (Item 6, WP 0092 00)
Wrench, Torque (Item 20, WP 0092 00)
Micrometer, Caliper (Item 13, WP 0092 00)
Hammer, Deadblow (Item 17, WP 0092 00)

Materials/Parts

Oil, Engine Lubricating (Item 25, WP 0119 00)
Rag, Wiping, Clean (Item 4, WP 0119 00)
Solvent, Degreasing (Item 24, WP 0119 00)
Grease, High Temp (Item 22, WP 0119 00)

Personnel Required

MOS 63J or 52C

Equipment Condition

Heater shut down and cool.
Engine bay access door open.
Main battery switch OFF and handle removed.
Burner fuel pump removed (WP 0033 00)
Balancer shaft removed (WP 0083 00)
Camshaft removed (WP 0084 00)
Connecting rod removed (WP 0088 00)

NOTE

Engine maintenance requires metric tools for the removal of all hardware and assemblies.

REMOVE

1. Remove flywheel housing **(1)** from cylinder block **(7)** by removing four screws **(2)**, washers **(3)**, collars **(4)**, and spacers **(5)**. Remove seal **(6)**.
2. Using flywheel locking handle, hold flywheel **(10)** in place and remove nut **(8)** and washer **(9)**.
3. Carefully remove flywheel **(10)** from crankshaft using flywheel remover. Use care to prevent damage to flywheel fins.
4. Remove key **(11)**. Remove bearing holder **(21)** and screw **(22)**.
5. Remove camshaft (WP 0084 00), balancer shaft (WP 0083 00), and connecting rod (WP 0088 00).
6. Carefully remove assembled crankshaft **(16)** from cylinder block, taking care not to damage oil seal **(14)**. Remove key **(20)**.
7. Drive crankshaft out of crankcase using a deadblow hammer.
8. Remove bolt **(12)** and washer **(13)**. Remove oil seal **(14)** and bearing **(15)** only if replacement is required.

REMOVE continued

NOTE

Bearing (17) and gears (18, 19) are supplied with crankshaft (16) as a matched set. Do not remove from crankshaft.

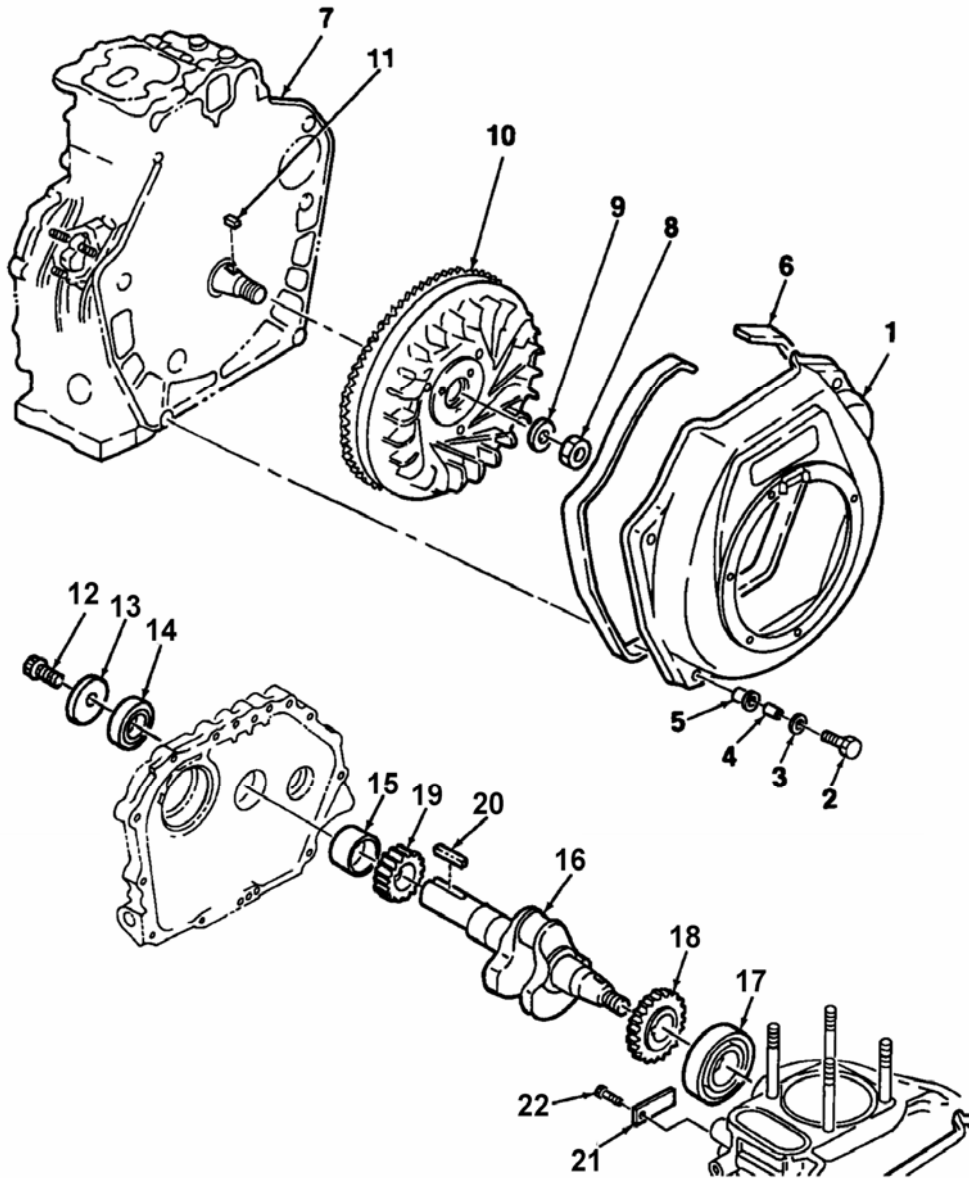

SERVICE**WARNING**

Cleaning solvents are flammable and toxic to eye, skin, and respiratory tract. Skin and eye protection are required when working in contact with cleaning solvents. Avoid repeated or prolonged contact. Work in well ventilated area only. Keep away from heat, sparks, and open flame. Do not smoke while using cleaning solvent. Failure to observe this warning can result in injury or death to personnel.

Clean components with cleaning solvent and a clean rag. Allow to air dry.

INSPECTION

1. Inspect flywheel **(10)** for cracks, deformation, or obvious damage. Inspect for broken, chipped, or cracked flywheel fins. Replace flywheel if damaged.
2. Inspect flywheel housing seal **(6)** for deterioration or permanent set. Replace if damaged or deformed.
3. Inspect crankshaft **(5)** for cracks, deformation, or obvious damage. Replace crankshaft if cracked or damaged.
4. Inspect gears **(7, 8)** for broken, chipped, or worn teeth. Replace gears and crankshaft **(5)** as an assembly if a gear is damaged or worn.
5. Measure the outside diameter (OD) of crankshaft crank pin. OD must be 1.4134 inches (35.90 mm), minimum. Replace crankshaft assembly if out of limits.
6. Measure the OD of crankshaft where crankshaft mates to crankcase cover plain bearing. OD must be 1.3744 inches (34.91 mm), minimum. Replace crankshaft assembly if out of limits.
7. Measure the OD of crankshaft where it mates to flywheel side ball bearing. OD must be 1.3782 inches (35.01 mm), minimum. Replace crankshaft assembly if out of limits.
8. Bearing **(6)** is press fit onto crankshaft **(5)**. Check bearing for looseness. Replace crankshaft assembly if bearing is loose.
9. Inspect bearing **(4)** for discoloration, separation, or any other obvious damage. Remove and replace bearing if damaged in any way.

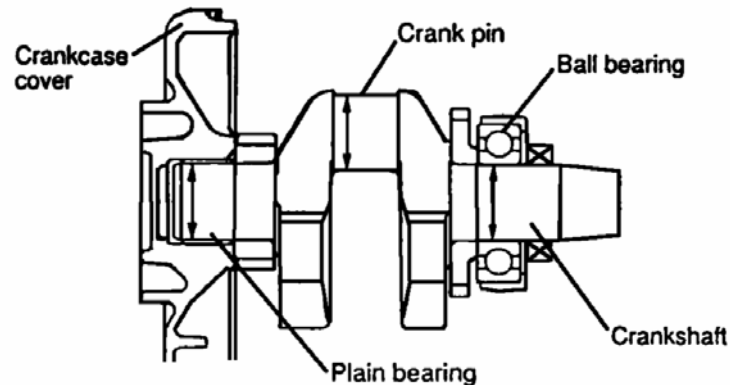

INSTALL

1. If installing a new bearing **(15)**, mount bearing so that oil groove in bearing faces up (see bearing installation illustration). Press fit bearing so that sinkage between face of bearing and face of crankcase cover is 0.0394 inch (1.0 mm).
2. Install a new oil seal **(14)**. Apply grease to oil seal and press into crankcase cover.
3. Install bolt **(12)** and washer **(13)**.
4. Apply grease to lips of oil seal **(14)**. Apply a light coat of oil to crankshaft **(16)** journal and pin.
5. Install key **(20)** into crankshaft **(16)**. Carefully insert assembled crankshaft into cylinder block. Make sure that crankshaft is inserted as far as it will go.
6. Tap into panel using a "soft face" hammer.
7. Install bearing holder **(21)** using screw **(22)**.
8. Install key **(11)**. Mate flywheel **(10)** to crankshaft, taking care not to damage crankshaft threads. Install washer **(9)** and nut **(8)**. Lock flywheel in place using locking handle and tighten nut to 87 to 94 foot-pounds (1200 to 1300 kg-cm).
9. Install seal **(6)** onto flywheel housing **(1)**.
10. Mate flywheel housing **(1)** to cylinder block **(7)**. Secure using four spacers **(5)**, collars **(4)**, washers **(3)**, and screws **(2)**.
11. Install connecting rod (WP 0088 00).
12. Install balancer shaft (WP 0083 00).
13. Install camshaft (WP 0084 00).
14. Install burner fuel pump (WP 0033 00).

Carefully fit the main bearing metal so that the oil groove is on the upper half.

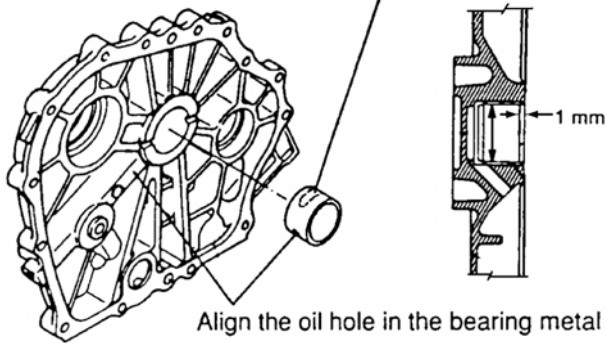

Align the oil hole in the bearing metal with the oil groove.

Bearing Installation

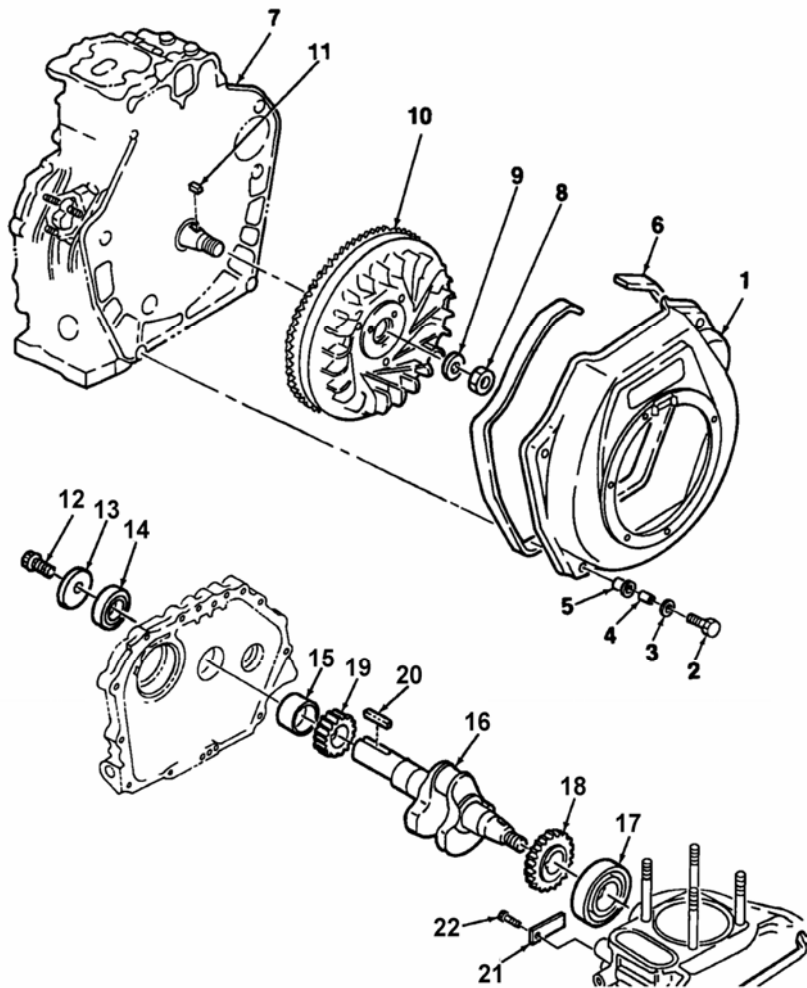

END OF WORK PACKAGE

**SUSTAINMENT (GENERAL) SUPPORT MAINTENANCE
LARGE CAPACITY FIELD HEATER (LCFH)
NSN 4520-01-500-1534
FUEL INJECTION PUMP
DISASSEMBLE, SERVICE, INSPECT, ASSEMBLE**

INITIAL SETUP:**Tools**

Tool Kit, General Mechanics (Item 2, WP 0092 00)

Personnel Required

MOS 63J or 52C

Materials/Parts

Solvent, degreasing (Item 24, WP 0119 00)

Rag, wiping, clean (Item 4, WP 0119 00)

Equipment Condition

Heater shut down and cool.

Engine bay access door open.

Main battery switch OFF and handle removed.

Fuel injection pump removed (WP 0043 00)

NOTE

Engine maintenance requires metric tools for the removal of all hardware and assemblies.

DISASSEMBLE

1. Remove valve holder **(1)** from body **(2)**. Remove delivery spring **(3)**.
2. Remove delivery valve **(4)** and gaskets **(5, 6)** from body **(2)**. Discard gaskets.
3. Disengage spring seat **(7)** from control lever **(8)**. Remove spring **(9)**, pin **(14)**, spring seat **(10)**, and control lever **(8)** from body **(2)**.
4. Remove plate **(11)**, gasket **(12)**, and plunger **(13)** from body **(2)**. Discard gasket.

SERVICE**WARNING**

Cleaning solvents are flammable and toxic to eye, skin, and respiratory tract. Skin and eye protection are required when working in contact with cleaning solvents. Avoid repeated or prolonged contact. Work in well ventilated area only. Keep away from heat, sparks, and open flame. Do not smoke while using cleaning solvent. Failure to observe this warning can result in injury or death to personnel.

Clean components with cleaning solvent and a clean rag. Allow to air dry.

INSPECTION

1. Inspect delivery valve **(4)** and plunger **(13)** for scores, pitting, or wear. Replace if damaged or worn.
2. Inspect springs **(3, 9)** for damage or deformation. Replace if damaged or deformed in any way.

ASSEMBLY

1. Insert plunger **(13)** into body **(2)**.
2. Install new gasket **(12)** and plate **(11)** onto body **(2)**. Install control lever **(8)** with tab on lever mating to hole on plate **(11)**.
3. Install spring seat **(10)** and pin **(14)**. Install spring **(9)** and spring seat **(7)**.
4. Install new gaskets **(5, 6)** onto delivery valve **(4)**. Insert spring **(3)** and delivery valve into valve holder **(1)**.
- 5. Install valve holder **(1)** into body **(2)**. Tighten holder to 261 to 303 inch-pounds (300 to 350 kg-cm).
6. Install fuel injection pump (WP 0043 00).

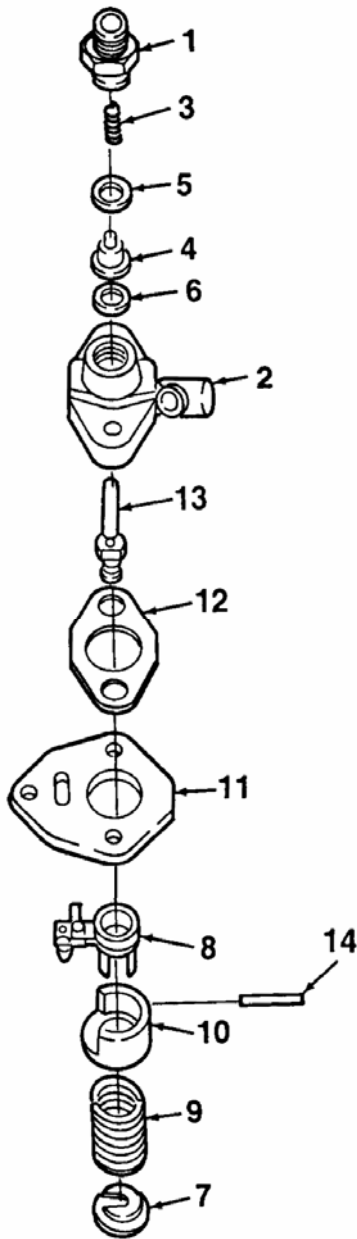

END OF WORK PACKAGE

SUSTAINMENT (GENERAL) SUPPORT MAINTENANCE**LARGE CAPACITY FIELD HEATER (LCFH)**

NSN 4520-01-500-1534

GOVERNOR**REMOVE, SERVICE, INSPECT, INSTALL**

INITIAL SETUP:**Tools**

Tool Kit, General Mechanics (Item 2, WP 0092 00)

Personnel Required

MOS 63J or 52C

Materials/PartsSolvent, degreasing (Item 24, WP 0119 00)
Rag, wiping, clean (Item 4, WP 0119 00)**Equipment Condition**Heater shut down and cool.
Engine bay access door open.
Main battery switch OFF and handle removed.
Governor control removed (WP 0075 00)
Camshaft assembly removed (WP 0084 00)

NOTE

Engine maintenance requires metric tools for the removal of all hardware and assemblies.

REMOVE

1. Reach into cylinder block and disengage governor (7) from governor lever assembly (3). Remove governor lever assembly from lever (1) by removing pin (2).
2. Remove washer (4), bearing (5), and bush (6).

SERVICE**WARNING**

Cleaning solvents are flammable and toxic to eye, skin, and respiratory tract. Skin and eye protections are required when working in contact with cleaning solvents. Avoid repeated or prolonged contact. Work in well ventilated area only. Keep away from heat, sparks, and open flame. Do not smoke while using cleaning solvent. Failure to observe this warning can result in injury or death to personnel.

Clean components with cleaning solvent and a clean rag. Allow to air dry.

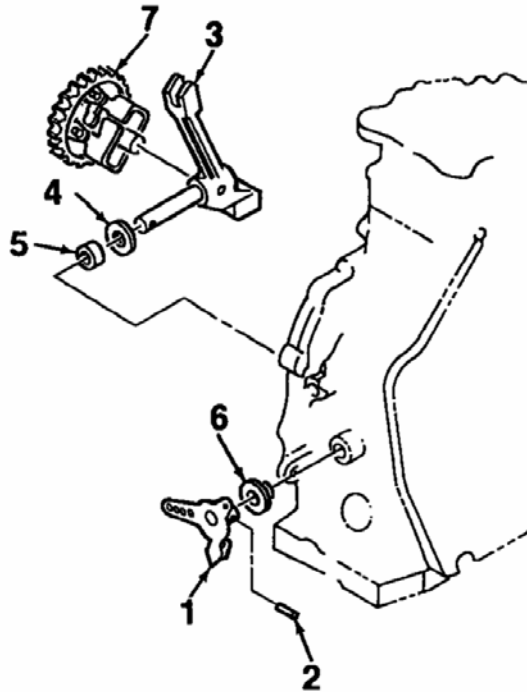

INSPECT

Inspect governor components for damage. Replace any part that is damaged in any way.

INSTALL

1. Install governor lever assembly (3), washer (4), and bearing (5) into cylinder block. Engage governor (7).
2. Install bushing (6). Mate lever (1) onto governor lever assembly (3) and secure using pin (2).
3. Install camshaft assembly (WP 0084 00).
4. Install governor control (WP 0075 00).

END OF WORK PACKAGE

**SUSTAINMENT (GENERAL) SUPPORT MAINTENANCE
LARGE CAPACITY FIELD HEATER (LCFH)
NSN 4520-01-500-1534
PISTON AND CONNECTING ROD
REMOVE, CLEAN, INSPECT, INSTALL**

INITIAL SETUP:**Tools**

Tool Kit, General Mechanics (Item 2, WP 0092 00)
Wrench, Torque (Item 12, WP 0092 00)
Micrometer, Caliper (Item 13, WP 0092 00)

Materials/Parts

Solvent, degreasing (Item 24, WP 0119 00)
Rag, wiping, clean (Item 4, WP 0119 00)

Personnel Required

MOS 63J or 52C

Equipment Condition

Heater shut down and cool.
Engine bay access door open.
Main battery switch OFF and handle removed.
Cylinder head removed (WP 0079 00)
Camshaft removed (WP 0084 00)
Balancer shaft removed (WP 0083 00)

NOTE

Engine maintenance requires metric tools for the removal of all hardware and assemblies.

REMOVE

1. Remove connecting rod nuts **(1)** and washers **(2)** from rod bolts **(3, 4)**.
2. Remove connecting rod cap **(5)** and lower bearing half **(6)** from crankshaft journal. Remove pins **(7)** only if replacement is required.
3. Rotate crankshaft to the top of its stroke so that piston **(8)** rises out of cylinder block. Remove assembled piston **(8)** and connecting rod **(9)** from crankcase. Remove upper bearing half **(10)**.

**WARNING**

Use extreme caution when handling hot components. Wear protective gloves. Failure to observe this warning can result in injury to personnel.

4. Remove two circlips **(11)** from piston pin **(12)**. Discard circlips. To remove piston pin from piston **(8)**, heat components to 158 to 176°F (70 to 80°C). Drive pin from piston and connecting rod **(9)**.
5. Remove piston rings **(13)** from piston **(8)**. Discard rings.
6. Remove rod bolts **(3, 4)** from connecting rod **(9)**.

CLEAN**WARNING**

Cleaning solvents are flammable and toxic to eye, skin, and respiratory tract. Skin and eye protection are required when working in contact with cleaning solvents. Avoid repeated or prolonged contact. Work in well ventilated area only. Keep away from heat, sparks, and open flame. Do not smoke while using cleaning solvent. Failure to observe this warning can result in injury or death to personnel.

1. Clean all components with cleaning solvent and a clean rag. Allow to air dry.
2. Remove carbon deposits from ring grooves of piston **(8)** by scraping with discarded ring. Rinse with cleaning solvent and allow to air dry.

CAUTION

Use care to prevent scratching of surface.

3. Remove carbon deposits from top of piston **(8)**.

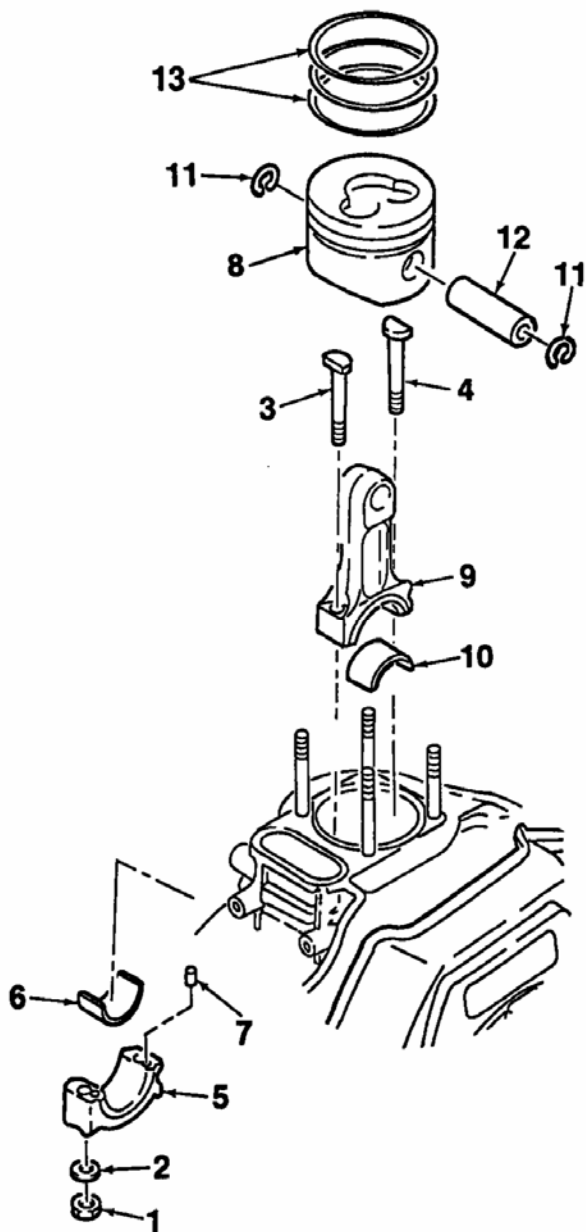

INSPECT

1. Inspect piston **(8)** and connecting rod **(9)** for cracks, deformation, or obvious damage. Inspect for uneven or excessive wear. Replace component if any damage is suspected.
2. Measure the outside diameter (OD) of piston, approximately 1/2 inch from the bottom. OD must be 3.0591 inches (77.70 mm), minimum. Replace piston if out of limits.
3. Measure the internal diameter (ID) of the piston pin hole in piston. ID must be 0.8295 inch (21.07mm), maximum. Replace piston if out of limits.
4. Measure the OD of piston pin **(12)** along the length of the pin. OD must be 0.8232 inch (20.91 mm), minimum. Replace piston pin if out of limits.
5. Using new piston ring set, measure the clearance between piston rings and piston grooves. Side clearance must be 0.0059 inch (0.15 mm), maximum. If clearance exceeds limit, replace piston.

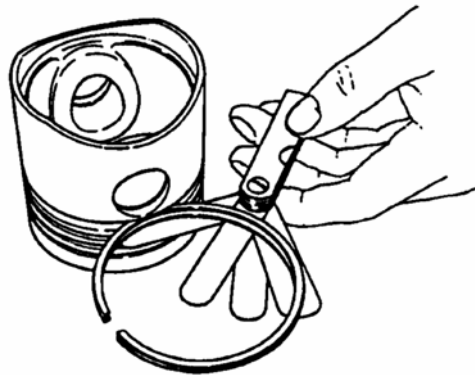
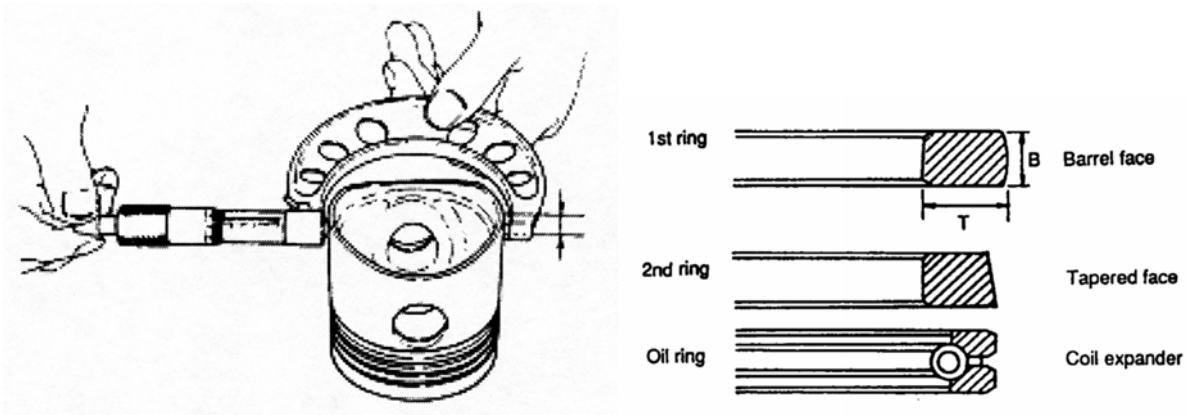

INSTALLATION

1. Install new ring set into piston ring grooves. Mount rings with end gaps staggered 120° apart (see illustration). Make sure that rings move smoothly in grooves.

**WARNING**

Use extreme caution when handling hot components. Wear protective gloves. Failure to observe this warning can result in injury to personnel.



2. To install piston pin **(12)** into piston **(8)** and connecting rod **(9)**, heat components to 158 to 176°F (70 to 80°C). Match marks on piston and connecting rod and install connecting rod into piston. Install piston pin **(12)** and allow components to cool.
3. Install new circlips **(11)** onto piston pin **(12)**. Insert rod bolts **(3, 4)** into connecting rod **(9)**.
4. Apply oil to the outer surface of piston **(8)**, the inner surface of the piston sleeve, and crankshaft crank pin. Carefully install upper bearing half **(10)**, piston **(8)**, and connecting rod **(9)** into cylinder block. Piston top mark must face crankcase cover side of cylinder block.
5. Install pins **(7)** into connecting rod cap **(5)**.
6. Install lower bearing half **(6)**. Mate connecting rod cap **(5)** to connecting rod **(9)**, ensuring match marks are aligned. Install nuts **(1)** and washers **(2)**. Tighten nuts to 157 to 182 inch-pounds (180 to 210 kg-cm).
7. Install balancer shaft (WP 0083 00).
8. Install camshaft (WP 0084 00).
9. Install cylinder head (WP 0079 00).

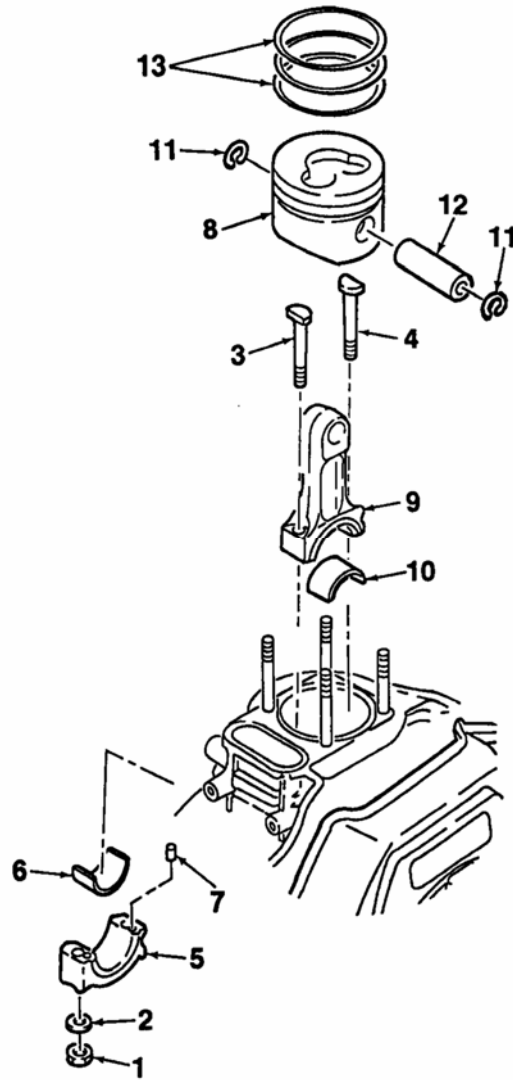

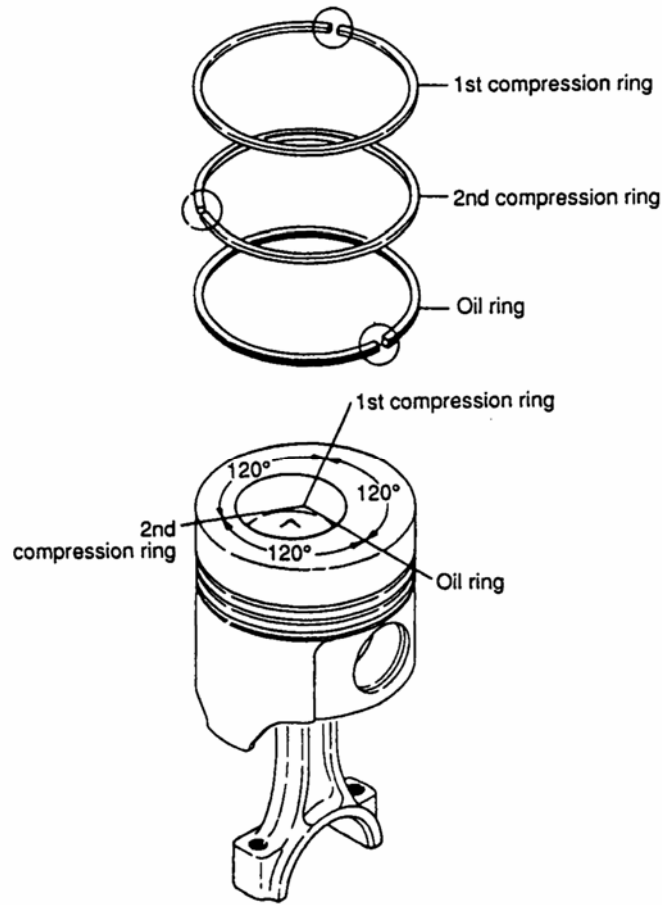

END OF WORK PACKAGE

SUSTAINMENT (GENERAL) SUPPORT MAINTENANCE**LARGE CAPACITY FIELD HEATER (LCFH)****NSN 4520-01-500-1534****ASSEMBLY, MAIN WIRING HARNESS
REPLACE**

INITIAL SETUP:**Tools**

Tool Kit, General Mechanics (Item 2, WP 0092 00)

Personnel Required

MOS 52C or 63J

Materials/PartsTags, marking (Item 5, WP 0119 00)
Tape, electrical (Item 6, WP 0119 00)
Wrap, tie (Item 9, WP 0119 00)**Equipment Condition**Heater shut down and cool.
Engine bay access door open.
Main battery switch in OFF position and handle removed.
Negative cable on battery closest to engine bay access door disconnected.

NOTE

If it is determined that the entire main wiring harness requires replacement, then there is a high probability that additional damage has been caused to other components within the system. Therefore, it may be necessary to inspect or test other components in the system to ensure that they are in good working order.

1. Tag and/or mark all connectors on the main wiring harness to ensure that the new main wire harness is connected correctly.
2. Disconnect all connectors on the main wiring harness.
3. Take note of all tie wraps locations that secure the main wiring harness to the heater chassis.
4. Clip all tie wraps that secure the wiring harness to the heater chassis. Do not clip the tie wraps that secure wires to the main wiring harness as a whole.
5. Take note of the position of the main wiring harness in the heater and carefully remove the defective main wiring harness.
6. Install the new main wiring harness in the same position as the defective main wiring harness.
7. Tie wrap the new main wiring harness to all previously noted locations along the heater chassis.
8. Reconnect all connectors according to tags and markings made earlier.
9. Remove all tags and/or markings.

END OF WORK PACKAGE

CHAPTER 11

SUPPORTING INFORMATION

LARGE CAPACITY FIELD HEATER (LCFH)

**OPERATOR, FIELD AND SUSTAINMENT MAINTENANCE
LARGE CAPACITY FIELD HEATER (LCFH)
REFERENCES**

SCOPE

This Work Package lists all field manuals, technical manuals, forms, pamphlets, Army regulations, and military standards referenced throughout this manual.

FIELD MANUALS

First Aid for Soldiers	FM 4-25.11
NBC Contamination Avoidance	FM 3-3/NAVFAC P-462
NBC Decontamination	FM 3-5/FM 11-10
NBC Operation	FM 3-100/FM 11-2
NBC Protection	FM 3-4/FM 11-9

TECHNICAL BULLETINS

Noise and Conservation of Hearing	TB MED 251
Hand Portable Fire Extinguishers Approved for Army Use	TB 5-4200-200-10
Specification List of Standard Liquid Fuels, Lubricants, Preservatives, and Related Products Authorized for Use by US Army	TB 703-1

TECHNICAL MANUALS

Administrative Storage of Equipment	TM 740-90-1
Army Maintenance Management System (TAMMS)	DA PAM 750-8
Destruction of Army Materiel to Prevent Enemy Use	TM 750-244-3
Ground Equipment Record Procedures	TM 4700-15/1
Preservation, Packaging, and Packing of Military Supplies and Equipment	TM 38-230-2
Processing and Inspection of Support Equipment for Storage and Shipment	TO 35-1-4
Radio Interference Suppression	TM11-483

FORMS

Equipment Inspection and Maintenance Worksheet	DA Form 2404
Product Quality Deficiency Report	DA Form 368
Recommended Changes to Equipment Technical Publication	DA Form 2028-2
Recommended Changes to Publications	DA Form 2028
Report Of Shipping (Item) And Packaging Discrepancy	SF 364
Report of Packaging and Handling Deficiencies	SF 362
Transportation and Travel Record of Transportation Discrepancies	SF 361

DA PAMPHLETS

The Army Maintenance Management System (TAMMS) DA PAM 750-8

PAINTING REQUIREMENTS

Color, Marking, and Preparation of Equipment for Shipment AR 740-1
Color and Marking of Army Material AR 746-5

MISCELLANEOUS

Army Regulations Handbook AR 310-2
Brazing of Steels, Copper, Copper Alloys, Nickel Alloys, Aluminum Alloys MIL-G-7883
Expendable Items (Except Medical Class V, Repair Parts and Heraldic Items) CTA 50-970
Fuels, Lubricants, Oil and Waxes C91001L
Hard Portable Fire Extinguishers Approved for Army Users TB 5-4200-200-10
Maintenance Reporting AFR 66-1
Production Quality Deficiency Report AFR 900-4

SPECIFICATIONS

Dry Cleaning Solvent Fed. Spec. P-D-680

**FIELD AND SUSTAINMENT MAINTENANCE
LARGE CAPACITY FIELD HEATER (LCFH)
MAINTENANCE ALLOCATION CHART, INTRODUCTION**

INTRODUCTION

The Army Maintenance System MAC

This introduction provides a general explanation of all maintenance and repair functions authorized at the two maintenance levels under the Two-Level Maintenance System concept.

The MAC (immediately following the introduction) designates overall authority and responsibility for the performance of maintenance functions on the identified end item or component. The application of the maintenance functions to the end item or component shall be consistent with the capacities and capabilities of the designated maintenance levels, which are shown on the MAC in column (4) as:

Field – includes two subcolumns, Unit (C (operator/crew) and O (unit) maintenance) and Direct Support (F) maintenance

Sustainment – includes two subcolumns, general support (H) and depot (D)

The tools and test equipment requirements (immediately following the MAC) list the tools and test equipment (both special tools and common tool sets) required for each maintenance function as referenced from the MAC.

The remarks (immediately following the tools and test equipment requirements) contain supplemental instructions and explanatory notes for a particular maintenance function.

Maintenance Functions

Maintenance functions will be limited to and are defined as follows:

1. **Inspect.** To determine the serviceability of an item by comparing its physical, mechanical, and/or electrical characteristics with established standards through examination (e.g., by sight, sound, or feel). This includes scheduled inspection and gaugings and evaluation of cannon tubes.
2. **Test.** To verify serviceability by measuring the mechanical, pneumatic, hydraulic, or electrical characteristics of an item and comparing those characteristics with prescribed standards on a scheduled basis, i.e., load testing of lift devices and hydrostatic testing of pressure hoses.
3. **Service.** Operations required periodically to keep an item in proper operating condition, e.g. to clean (includes decontaminate, when required), to preserve, to drain, to paint, or to replenish fuel, lubricants, chemical fluids, or gases. This includes scheduled exercising and purging of recoil mechanisms.
4. **Adjust.** To maintain or regulate, within prescribed limits, by bringing into proper position, or by setting the operating characteristics to specified parameters.
5. **Align.** To adjust specified variable elements of an item to bring about optimum or desired performance.
6. **Calibrate.** To determine and cause corrections to be made, or to be adjusted on instruments of test, measuring, and diagnostic equipment used in precision measurement. Consists of comparisons of

two instruments, one of which is a certified standard of known accuracy, to detect and adjust any discrepancy in the accuracy of the instrument being compared.

7. Remove/Install. To remove and install the same item, when required, to perform service or other maintenance functions. Install may be the act of emplacing, seating, or fixing into position a spare, repair part, or module (component or assembly) in a manner to allow the proper function of equipment or system.
8. Replace. To remove an unserviceable item and install a serviceable counterpart in its place. "Replace" is authorized by the MAC and is shown as the 3rd position code of the Source, Maintenance, and Recoverability (SMR) code.
9. Repair. The application of maintenance services, including fault location/troubleshooting, removal/installation, and disassembly/assembly procedures, and maintenance actions to identify troubles, and restore serviceability to an item by correcting specific damage, fault, malfunction, or failure in a part, subassembly, module (component or assembly), end item, or system.

NOTE

The following definitions are applicable to the "repair" maintenance function:

Services - Inspect, test, service, adjust, align, calibrate, and/or replace.

Fault location/troubleshooting - The process of investigating and detecting the cause of equipment malfunctioning; the act of isolating a fault within a system or Unit Under Test (UUT).

Disassembly/assembly - The step by step breakdown (taking apart) of a spare/functional group coded item to the level of its least component, that is assigned an SMR code for the level of maintenance under consideration (i.e., identified as maintenance significant).

Actions - Welding, grinding, riveting, straightening, facing, machining, and/or resurfacing.

10. Overhaul. That maintenance effort (service/action) prescribed to restore an item to a completely serviceable/operational condition as required by maintenance standards in appropriate technical publications. Overhaul is normally the highest degree of maintenance performed by the Army. Overhaul does not normally return an item to like new condition.
11. Rebuild. Consists of those services/actions necessary for the restoration of unserviceable equipment to a like new condition in accordance with original manufacturing standards. Rebuild is the highest degree of materiel maintenance applied to Army equipment. The rebuild operation includes the act of returning to zero those age measurements (e.g. hours/miles) considered in classifying Army equipment/components.

Explanation of Columns in the MAC

Column (1) -- Group Number. Column (1) lists functional group code numbers (FGC), the purpose of which is to identify maintenance significant components, assemblies, subassemblies, and modules with the Next Higher Assembly (NHA).

Column (2) -- Component/Assembly. Column (2) contains the item names of components, assemblies, subassemblies, and modules for which maintenance is authorized.

Column (3) -- Maintenance Function. Column (3) lists the functions to be performed on the item listed in column (2). (For detailed explanation of these functions, refer to "Maintenance Functions" outlined above.)

Column (4) -- Maintenance Level. Column (4) specifies the level of maintenance authorized to perform the function listed in Column (3), by indicating work time required (expressed as man-hours in whole hours or decimals) in the appropriate subcolumn. This work time figure represents the active time required to perform that maintenance function at the indicated level of maintenance. If the number or the complexity of the tasks within the listed maintenance function vary at different maintenance levels, appropriate work time figures are to be shown for each level. The work time figure represents the average time required to restore an item (assembly, subassembly, component, module, end item, or system) to a serviceable condition under typical field operating conditions. This time includes preparation time (including any necessary disassembly/assembly time), troubleshooting/fault location time, and quality assurance time in addition to the time required to perform the specific tasks identified for the maintenance functions authorized in the MAC. The symbol designations for the various maintenance levels are shown below:

Field:

C -- Operator or crew maintenance
O -- Unit Maintenance
F -- Direct Support Maintenance

Sustainment:

H -- General Support Maintenance
D -- Depot Maintenance

NOTE

The "L" maintenance level is not included in column (4) of the MAC. Functions to this level of maintenance are identified by a work time figure in the "H" column of column (4), and an associated reference code is used in the REMARKS column (6). This code is keyed to the remarks and the SRA complete repair application is explained there.

Column (5) -- Tools and Equipment Reference Code. Column (5) specifies, by code, those common tool sets (not individual tools) common Test, Measurement, and Diagnostic Equipment (TMDE), and special tools, special Test, Measurement, Diagnostic Equipment (TMDE), and support equipment required to perform the designated function. Codes are keyed to the entries in the tools and test equipment table.

Column (6) -- Remarks Code. When applicable, this column contains a letter code, in alphabetical order, which is keyed to the remarks table entries.

Explanation of Columns in the Tools and Test Equipment Requirements

Column (1) Tool or Test Equipment Reference Code. The tool or test equipment reference code correlates with a code used in column (5) of the MAC.

Column (2) Maintenance Level. The lowest level of maintenance authorized to use the tool or test equipment.

Column (3) Nomenclature. Name or identification of tool or test equipment.

Column (4) National Stock Number (NSN). The NSN of the tool or test equipment.

Column (5) Tool Number. The manufacturer's part number, model number, or type number.

Explanation of Columns in Remarks

Column (1) Remarks Code. The code recorded in Column (6) of the MAC.

Column (2) Remarks. This column lists information pertinent to the maintenance function being performed as indicated in the MAC.

**OPERATOR, FIELD AND SUSTAINMENT MAINTENANCE
LARGE CAPACITY FIELD HEATER (LCFH)
MAINTENANCE ALLOCATION CHART**

Table 1. Maintenance Allocation Chart (MAC) for Large Capacity Field Heater (LCFH).

(1) GROUP NUMBER	(2) COMPONENT/ ASSEMBLY	(3) MAINTENANCE FUNCTION	(4) MAINTENANCE LEVEL					(5) TOOLS AND EQUIPMENT REF CODE	(6) REMARKS CODE
			FIELD		SUSTAINMENT				
			UNIT		DIRECT SUPPORT	GENERAL SUPPORT	DEPOT		
			C	O	F	H	D		
00	LARGE CAPACITY FIELD HEATER (LCFH)								
01	ASSEMBLY, CABINET	Inspect Service	.2	.1			2	A	
0101	INSULATION, SHEET SOUND	Inspect Replace	.1	.5			2,8	A	
0102	ASSEMBLY, JACK	Inspect Replace	.1	.4			2	A	
0103	CABINET	Inspect Repair	.1	.2	.5		2	A	
0104	INSTALLATION, WHEEL RETRACTION ASSEMBLY	Inspect Replace	.1 .2					A	
0105	LATCH, DOOR	Inspect Service Replace	.1	.1 .3			2,10	A	
0106	BRACKET, MOUNTING, OPERATOR BOX	Inspect Replace	.1	.3			2,10	A	
0107	CO DETECTOR, CABINET MOUNTED	Inspect Test Replace		.3 .3 .5			2 2 2		
0108	EXHAUST TUBE, HEAT EXCHANGER	Inspect Repair	.1	.2			2	A	
02	ASSEMBLY, FUEL SYSTEM	Inspect Repair Replace	.1	.7 1.5			2 2		
0201	FILTER, 10- MICRON FUEL	Inspect Service Replace	.1	.2 .5			9 2	A	
0202	PUMP, FUEL, ELECTRICAL	Inspect Service Replace	.1	.2 .5			2	A	

Table 1. Maintenance Allocation Chart (MAC) for Large Capacity Field Heater (LCFH).

(1) GROUP NUMBER	(2) COMPONENT/ ASSEMBLY	(3) MAINTENANCE FUNCTION	(4) MAINTENANCE LEVEL					(5) TOOLS AND EQUIPMENT REF CODE	(6) REMARKS CODE
			FIELD		SUSTAINMENT				
			UNIT		DIRECT SUPPORT	GENERAL SUPPORT	DEPOT		
			C	O	F	H	D		
0203	VALVE, SOLENOID, FUEL, 3-WAY	Replace		.5				2	
0204	SWITCH, BATTERY POWER, MAIN	Inspect Test Replace	.1	.3 .7				2 2	A
0205	MECHANICAL HOUR METER	Test Replace		1.0 .4				2	E
0206	ASSEMBLY, FUEL VALVES, BURNER	Inspect Repair Replace		.3 .5 .7				2 2	A
020601	SOLENOID VALVE, 3-WAY FUEL	Replace		.5				2	
020602	SOLENOID VALVE, 2-WAY FUEL	Replace		.5				2	
020603	ASSEMBLY, BURNER FUEL PUMP	Inspect Adjust Replace		.2 .3 .5				2 2	A
0207	FUEL TANK	Inspect Service Repair Replace	.1 .3	.5 1.0				2 2	A
020701	SWITCH, FUEL TANK LEVEL	Replace		.5				2	
0208	CONNECTOR, EXTERNAL, FUEL SUPPLY	Inspect Replace	.1	.4				2	A
0209	ASSEMBLY, FUEL HOSE EXTERNAL	Inspect Replace	.1	.3				2	A
0210	ASSEMBLY, RELAY BOX	Repair		.7				2	
03	POWER PLANT INSTALLATION	Inspect Repair Replace							
0301	ASSEMBLY, INLET FAN	Inspect Replace	.1	.1 1.0				2	A
0302	SCREEN, SAFETY	Inspect Replace	.1	.3				2	

Table 1. Maintenance Allocation Chart (MAC) for Large Capacity Field Heater (LCFH).

(1) GROUP NUMBER	(2) COMPONENT/ ASSEMBLY	(3) MAINTENANCE FUNCTION	(4) MAINTENANCE LEVEL					(5) TOOLS AND EQUIPMENT REF CODE	(6) REMARKS CODE
			FIELD		SUSTAINMENT				
			UNIT		DIRECT SUPPORT	GENERAL SUPPORT	DEPOT		
			C	O	F	H	D		
0303	ASSEMBLY, ENGINE SYSTEM	Inspect Repair Replace	.1	1.0	2.0			2 2	A
030301	ASSEMBLY, 24V ALTERNATOR WITH PULLEY	Inspect Test Adjust Replace	0.1	0.5 0.2 0.8				2 2 2	A
030302	ASSEMBLY, COUPLING	Inspect Replace	0.1	.5				2,12	A
030303	ENGINE, DIESEL	Inspect Service Test Replace Repair	0.1	0.1 0.2 0.2 1.2	0.5 3.0 1.0	2.0		1,2 1-4 1-5,12 1-6	A A,C
03030301	CRANKCASE COVER	Inspect Rem/Inst	0.1	0.1	1.0			1-6,12	A D
0303030101	CRANKSHAFT	Inspect Rem/Inst Repair				0.5 2.0 0.5		3,4 3-6,20 3,4	D
0303030102	BALANCER SHAFT ASSY	Inspect Rem/Inst Repair				0.4 1.5 1.0		3,4 3,4,12 3,4	D
0303030103	CAMSHAFT ASSY	Inspect Rem/Inst Repair				0.4 1.5 1.0		3,4 3,4,12 3,4	D
0303030104	PISTON AND CONNECTING ROD	Inspect Service Rem/Inst Repair				0.5 1.5 1.5 0.5		3,4 3,4 3,4,12 3,4	A D
0303030105	CYLINDER HEAD	Inspect Rem/Inst Repair		0.1 0.8	2.5 2.8			1,2 3,4,12	D
030303010501	ROCKER ARM ASSY	Inspect Adjust Rem/Inst Repair		0.5	0.4 1.0 1.3			3,4 1,2 3,4,12 3,4	A D
03030302	AIR CLEANER ASSY	Inspect Service Rem/Inst Repair	0.1 0.1	0.1 0.3 0.5 0.5				1,2 1,2	A A, B D
03030303	OIL PUMP AND FILTER	Inspect Rem/Inst Repair		0.4	0.4 1.5 1.5			3,4 3,4 3,4	A D

Table 1. Maintenance Allocation Chart (MAC) for Large Capacity Field Heater (LCFH).

(1) GROUP NUMBER	(2) COMPONENT/ ASSEMBLY	(3) MAINTENANCE FUNCTION	(4) MAINTENANCE LEVEL					(5) TOOLS AND EQUIPMENT REF CODE	(6) REMARKS CODE	
			FIELD		SUSTAINMENT					
			UNIT		DIRECT SUPPORT	GENERAL SUPPORT	DEPOT			
			C	O	F	H	D			
03030304	INJECTION PUMP ASSY	Inspect Adjust Rem/Inst Repair	0.1		0.2 0.5 0.8		1.0		3,4 3,4,19 3,4	A D
03030305	FUEL INJECTOR	Inspect Adjust Rem/Inst Repair	0.1		0.2 0.5 0.8				3,4 3,4,19 3,4	A D
03030306	ASSEMBLY, ELECTRIC STARTER	Inspect Adjust Rem/Inst Repair	0.1	0.5 0.8	0.2				3,4 3,4 3,4	A D
03030307	ASSEMBLY, FLYWHEEL	Inspect Adjust Rem/Inst Repair	0.1	0.2 0.5 0.8					3,4 3,4 3,4	A D
03030308	GOVERNOR CONTROL	Inspect Adjust Rem/Inst Repair	0.1		0.2 0.5 0.8		1.0		3,4 3,4 3,4	A D
030304	SOLENOID, ENGINE SHUTDOWN	Service Replace		.1 .5					2	
04	INSTALLATION, HEAT SYSTEM	Inspect Service Repair Replace								
0401	BLOWER, COMBUSTION	Inspect Test Replace		.1 .3 .7					2 2	A
0402	ASSEMBLY, IGNITION	Inspect Replace		.1 .4					2	A
0403	SENSOR, FLAME	Inspect Test Replace		.1 .3 .4					2 2	A
0404	ASSEMBLY, BURNER NOZZLE AND ELECTRODE	Remove Adjust Service Install Replace		.2 .3 .2 .2 .2					2 2 2 2 2	A
040401	ASSEMBLY, BURNER ELECTRODE	Remove Adjust Service Install Replace		.2 .3 .2 .2 .2					2 2 2 2 2	

Table 1. Maintenance Allocation Chart (MAC) for Large Capacity Field Heater (LCFH).

(1) GROUP NUMBER	(2) COMPONENT/ ASSEMBLY	(3) MAINTENANCE FUNCTION	(4) MAINTENANCE LEVEL					(5) TOOLS AND EQUIPMENT REF CODE	(6) REMARKS CODE
			FIELD		SUSTAINMENT				
			UNIT		DIRECT SUPPORT	GENERAL SUPPORT	DEPOT		
			C	O	F	H	D		
040402	ASSEMBLY, NOZZLE BURNER	Remove		.2				2	
		Adjust		.3				2	
		Service		.2				2	
		Install		.2				2	
		Replace		.2				2	
0405	CONE, BURNER	Inspect		.5				2	A
		Service		.7				2	A
0406	ASSEMBLY, HEAT EXCHANGER	Inspect		.1				2	A
		Service		.5				2	
		Replace		1.5				2	
040601	SENSOR, OUTLET TEMPERATURE	Test		.3				7	
		Replace		.5				2	
05	ASSEMBLY, WIRE HARNESS	Inspect		.3					A
		Test		.2				7	
		Repair		.2				2	
		Replace				3		2	
06	POWER CONNECTIONS INSTALLATION	Inspect		.2					A
		Service		.3				2	
		Test		.3				7	
		Repair		.2				2	
		Replace		.4				2	
0601	ASSEMBLIES, BATTERY TERMINAL, CABLE AND POWER	Inspect		.1					A
		Service		.2				2	
		Replace		.4				2	
0602	BATTERY	Inspect		.1				7	A
		Test		.5				14	
		Replace		.5				2	
0603	ASSEMBLY, BATTERY T-BAR AND HOLD DOWN	Inspect	.1						A
		Replace		.2				2	
07	RECEPTACLE, SLAVE	Remove		.3					
		Inspect		.1				7	
		Install		.5				2	
08	ASSEMBLY, MAIN CONTROL BOX	Replace		.5				2	

Table 1. Maintenance Allocation Chart (MAC) for Large Capacity Field Heater (LCFH).

(1) GROUP NUMBER	(2) COMPONENT/ ASSEMBLY	(3) MAINTENANCE FUNCTION	(4) MAINTENANCE LEVEL					(5) TOOLS AND EQUIPMENT REF CODE	(6) REMARKS CODE	
			FIELD		SUSTAINMENT					
			UNIT		DIRECT SUPPORT	GENERAL SUPPORT	DEPOT			
			C	O	F	H	D			
09	ASSEMBLY, OPERATOR CONTROL BOX	Inspect	.1							
		Repair	.5					2		
		Replace	.2					2		
0901	ASSEMBLY, OPERATOR CONTROL BOX CABLE	Inspect	.1							
		Test		.4				7		
0902	DETECTOR, CO - OPERATOR CONTROL BOX	Replace		.2				2		
		Inspect	.1							
		Test	.1							
10	AIR DUCT, INSULATED, 16 IN. X 15 FT.	Replace		.3				2		
		Inspect	.1							
		Remove	.2							
11	DUCT COVERS	Repair	.1							
		Inspect	.1							

Table 2. Tools and Test Equipment for Large Capacity Field Heater (LCFH).

TOOL OR TEST EQUIPMENT REF CODE	MAINTENANCE LEVEL	NOMENCLATURE	NATIONAL STOCK NUMBER	TOOL NUMBER
1	O	SHOP EQUIPMENT, AUTOMOTIVE MAINTENANCE AND REPAIR	4910-00-754-0654	5C491 0-95-CL-A74
2	O	TOOL KIT, GENERAL MECHANIC'S AUTOMOTIVE	5180-00-177-7033	SCSI 80-90-CL-N26
3	F, H	TOOL KIT, MASTER MECHANIC'S	5180-00-699-5273	SCSI 80-90-CL-N05
4	F, H	SHOP EQUIPMENT, AUTOMOTIVE MAINTENANCE AND REPAIR, FIELD BASIC, LESS POWER	4910-00-754-0705	5C4910-95-CL-A31
5	H	HANDLE, FLYWHEEL LOCKING	5120-01-415-8266	114250-92101
6	H	REMOVER, FLYWHEEL	5120-01-416-0424	114250-92130
7	O,F	MULTIMETER	6625-00-999-6282	
8	O,F	HEAT GUN, ELECTRIC	4940-01-215-0985	
9	O,F	WRENCH, OIL FILTER	5120-01-197-6721	
10	O,F,H	RIVETER, BLIND HAND ST, STRAIGHT HEAD; FOR 1/8, 9/64, & 0.188 IN RIVET SIZES	5120-00-357-6065	
11	O,F,H	TOOL, ELECTRODE ADJUSTING		40791
12	O,F,H	WRENCH, TORQUE	5120-01-394-4295	810748
13	O,F,H	MICROMETER, CALIPER	5210-00-255-7564	
14	O,F,H	TEST SET, BATTERY	6625-00-295-1902	
15	O,F,H	ADAPTER, 3/8 IN DRIVE SOCKET TO 1/4 IN HEX KEY	LOCAL PURCHASE	
16	O,F,H	PADS, KNEE	LOCAL PURCHASE	
17	O,F,H	HAMMER, HAND	5120-00-902-0089	B753F
18	O,F,H	LIFT, CHAIN	LOCAL PURCHASE	
19	O,F	WRENCH, TORQUE	5120-01-394-4291	810761
20	H	WRENCH, TORQUE	5120-01-394-4299	810757

Table 3. Remarks for Large Capacity Field Heater (LCFH).

REMARKS CODE	REMARKS
A	PREVENTIVE MAINTENANCE CHECKS AND SERVICES (PMCS)
B	SERVICE CONSISTS OF AIR FILTER CHANGE
C	SERVICE IN ACCORDANCE WITH LUBRICATION INSTRUCTIONS, WP 0018 00
D	REPAIR IS LIMITED TO REPLACEMENT OF DAMAGED PARTS
E	TEST TIME INCLUDES OPERATION OF HEATER TO VERIFY CORRECT OPERATION

**FIELD AND SUSTAINMENT MAINTENANCE
LARGE CAPACITY FIELD HEATER (LCFH)
(NSN 4520-01-500-1534)
REPAIR PARTS AND SPECIAL TOOLS LIST INTRODUCTION**

SCOPE

This Repair Parts and Special Tools List (RPSTL) lists and authorizes spare and repair parts; special tools; special test, measurement and diagnostic equipment (TMDE); and other special support equipment required for performance of Operator, Field and Sustainment maintenance of the Large Capacity Field Heater. It authorizes the requisitioning, issue, and disposition of spares, repair parts, and special tools as indicated by the source, maintenance, and recoverability (SMR) codes.

GENERAL

In addition to the Introduction Work Package, this RPSTL is divided into the following work packages:

1. Repair Parts List Work Packages. Work packages containing lists of spares and repair parts authorized by this RPSTL for use in the performance of maintenance. These work packages also include parts which must be removed for replacement of the authorized parts. Parts lists are composed of functional groups in ascending alphanumeric sequence, with the parts in each group listed in ascending figure and item number sequence. Sending units, brackets, filters, and bolts are listed with the component they mount on. Bulk materials are listed by item name in FIG. BULK at the end of the work packages. Repair parts kits are listed separately in their own functional group and work package. Repair parts for reparable special tools are also listed in a separate work package. Items listed are shown on the associated illustrations.
2. Special Tools List Sections. Work packages containing lists of special tools, special TMDE, and special support equipment authorized by RPSTL (as indicated by Basis of Issue (BOI) information in the DESCRIPTION AND USABLE ON CODE (UOC) COLUMN). Tools that are components of common tool sets and/or Class VII are not listed.
3. Cross-Reference Indexes Work Packages. There are two cross-reference indexes work packages in this RPSTL: the National Stock Number (NSN) Index work package and the Part Number (P/N) Index work package. The National Stock Number Index work package refers you to the figure and item number. The Part Number Index work package refers you to the figure and item number.

EXPLANATION OF COLUMNS IN THE REPAIR PARTS LIST AND SPECIAL TOOLS LIST WORK PACKAGES

ITEM NO. (Column (1)). Indicates the number used to identify items called out in the illustration.

SMR CODE (Column (2)). The Source, Maintenance, and Recoverability (SMR) code containing supply/requisitioning information, maintenance level authorization criteria and disposition instruction, as shown in the following breakout.

Source Code	Maintenance Code	Recoverability Code	
----	----	----	----
XX	X	X	X
----	----	----	----
1st two Positions: How to get an item.	3rd Position: Who can install, replace or use the item.	4th Position: Who can do complete repair* on the item.	5th Position: Who determines disposition action on unserviceable items.

* Complete Repair: Maintenance capacity, capability, and authority to perform all corrective maintenance tasks of the "Repair" function in a use/user environment in order to restore serviceability to a failed item.

Source Code. The source code tells you how to get an item needed for maintenance, repair, or overhaul of an end item/equipment. Explanation of source codes follows.

Source Code	Explanation
PA	Stock items; use the applicable NSN to request/requisition items with these source codes. They are authorized to the category indicated by the code entered in the third position of the SMR code.
PB	
PC**	NOTE: Items coded PC are subject to deterioration.
PD	
PE	Items with these codes are not to be requested/requisitioned individually. They are part of a kit which is authorized to the maintenance level indicated in the 3rd position of the SMR code. The complete kit must be requisitioned and applied.
PF**	
PG	
KB	
KD	
KF	
MO-(Made at Unit/ AVUM Level)	Items with these codes are not to be requested/requisitioned individually. They must be made from bulk material which is identified by the P/N in the DESCRIPTION AND USABLE ON CODE (UOC) column and listed in the bulk material group work package of the RPSTL. If the item is authorized to you by the 3rd position code of the SMR code, but the source code indicates it is made at a higher level, order the item from the higher level of maintenance.
MF-(Made at DS/ AVIM Level)	
MH-(Made at GS Level)	
ML-(Made at Spe- cialized Repair Act (SRA))	
MD-(Made at Depot)	
AO-(Assembled by Unit/AVUM Level)	
AF-(Assembled by DS/AVIM Level)	Items with these codes are not to be requested/requisitioned individually. The parts that make up the assembled item must be requisitioned or fabricated and assembled at the level of maintenance indicated by the source code. If the third position code of the SMR code authorizes you to replace the item, but the source code indicates the item is assembled at a higher level, order the item from the higher level of maintenance.
AH-(Assembled by GS level)	
AL-(Assembled by SRA)	
AD-(Assembled by Depot)	
XA	Do not requisition an "XA" coded item. Order its next higher assembly. (Also, refer to the NOTE below.)
XB	If an "XB" item is not available from salvage, order it using the CAGEC and part number given.
XC	Installation drawing, diagram, instruction sheet, field service drawing, that is identified by manufacturer's part number.
XD	Item is not stocked. Order an "XD" coded item through normal supply channels using the CAGEC and part number given, if no NSN is available.

NOTE

Cannibalization or controlled exchange, when authorized, may be used as a source of supply for items with the above source codes, except for those source coded "XA" or those aircraft support items restricted by requirements of AR 750-1.

Maintenance Code. Maintenance codes tell you the level(s) of maintenance authorized to use and repair support items. The maintenance codes are entered in the third and fourth positions of the SMR Code as follows:

Third Position. The maintenance code entered in the third position tells you the lowest maintenance level authorized to remove, replace, and use the support item. The maintenance code entered in the third position will indicate authorization to one of the following levels of maintenance.

Maintenance

Code	Application/Explanation
C	Crew or operator maintenance done within unit/AVUM maintenance.
O	Unit level/AVUM maintenance can remove, replace, and use the item.
F	Direct support/AVIM maintenance can remove, replace, and use the item.
H	General support maintenance can remove, replace, and use the item.
L	Specialized repair activity can remove, replace, and use the item.
D	Depot level can remove, replace, and use the item.

Fourth Position. The maintenance code entered in the fourth position tells whether or not the item is to be repaired and identifies the lowest maintenance level with the capability to do complete repair (i.e., perform all authorized repair functions).

NOTE

Some limited repair may be done on the item at a lower level of maintenance, if authorized by the Maintenance Allocation Chart (MAC) and SMR codes.

Maintenance

Code	Application/Explanation
O	Unit/AVUM is the lowest level that can do complete repair of the item.
F	Direct support/AVIM is the lowest level that can do complete repair of the item.
H	General support is the lowest level that can do complete repair of the item.
L	Specialized repair activity (SRA) is the lowest level that can do complete repair of the item.
D	Depot is the lowest level that can do complete repair of the item.
Z	Nonrepairable. No repair is authorized.

B No repair is authorized. No parts or special tools are authorized for the maintenance of a "B" coded item. However, the item may be reconditioned by adjusting, lubricating, etc., at the user level.

Recoverability Code. Recoverability codes are assigned to items to indicate the disposition action on unserviceable items. The recoverability code is entered in the fifth position of the SMR Code as follows:

Code	Application/Explanation
Z	Nonreparable item. When unserviceable, condemn and dispose of the item at the level of maintenance shown in 3rd position of SMR Code.
O	Reparable item. When uneconomically repairable, condemn and dispose of the item at organizational or aviation unit level.
F	Reparable item. When uneconomically repairable, condemn and dispose of the item at the direct support level.
H	Reparable item. When uneconomically repairable, condemn and dispose of the item at the general support level.
D	Reparable item. When beyond lower level repair capability, return to depot. Condemnation and disposal of item not authorized below depot level.
L	Reparable item. Condemnation and disposal not authorized below Specialized Repair Activity (SRA).
A	Item requires special handling or condemnation procedures because of specific reasons (such as precious metal content, high dollar value, critical material, or hazardous material). Refer to appropriate manuals/directives for specific instructions.

National Stock Number (NSN) (Column (3)). The NSN for the item is listed in this column.

CAGEC (Column (4)). The Commercial and Government Entity Code (CAGEC) is a 5-digit code which is used to identify the manufacturer, distributor, or Government agency/activity that supplies the item.

PART NUMBER (Column (5)). Indicates the primary number used by the manufacturer (individual company, firm, corporation, or Government activity), which controls the design and characteristics of the item by means of its engineering drawings, specifications, standards, and inspection requirements to identify an item or range of items.

NOTE

When you use an NSN to requisition an item, the item you receive may have a different P/N from the number listed.

DESCRIPTION and Usable On Code (UOC) (Column (6)). This column includes the following information:

1. The federal item name and, when required, a minimum description to identify the item.
2. P/Ns of bulk materials are referenced in this column in the line entry to be manufactured/fabricated.

3. Hardness Critical Item (HCI). A support item that provides the equipment with special protection from electromagnetic pulse (EMP) damage during a nuclear attack.
4. The statement "END OF FIGURE" appears just below the last item description in Column (6) for a given figure in both the repair parts list and special tools list work packages.

QTY (Column (7)). The QTY (quantity per figure) column indicates the quantity of the item used in the breakout shown on the illustration/figure, which is prepared for a functional group, subfunctional group, or an assembly. A "V" appearing in this column instead of quantity indicates that the quantity is a variable with each application.

EXPLANATION OF CROSS-REFERENCE INDEXES WORK PACKAGES FORMAT AND COLUMNS

National Stock Number (NSN) Index Work Package.

STOCK NUMBER Column. This column lists the NSN in National item identification number (NIIN) sequence. The NIIN consists of the last nine digits of the NSN, i.e.,

NSN
5305-01-574-1467
NIIN

When using this column to locate an item, ignore the first four digits of the NSN. Use the complete NSN (13 digits) when requisitioning by stock number.

FIG. Column. This column lists the number of the figure where the item is identified/located. The figures are in the repair parts list and special tools list work packages.

ITEM Column. The Item number identifies the item associated with the figure listed in the adjacent FIG. Column. This item is also identified by the NSN listed on the same line.

2. Part Number (P/N) Index Work Package. P/Ns in this index are listed in ascending alphanumeric sequence (i.e., vertical arrangement of letter and number combinations which place the first letter or digit of each group in order A through Z, followed by the numbers 0 through 9, and each following letter or digit in like order).

PART NUMBER Column. Indicates the P/N assigned to the item.

FIG. Column. This column lists the number of the figure where the item is identified/located in the repair parts list and special tools list work packages.

ITEM Column. The item number is the number assigned to the item as it appears in the figure referenced in adjacent figure number column.

SPECIAL INFORMATION

USABLE ON CODE (UOC). The usable on code appears in the lower left corner of the Description Column heading. Usable on codes are shown as "UOC: ..." in the Description Column (justified left) on the first line under the applicable item/nomenclature. Uncoded items are applicable to all models. Identification of the usable on codes used in this RPSTL are:

<u>Code</u>	<u>Used On</u>
61S	LCFH

Fabrication Instructions. Bulk materials required to manufacture items are listed in the bulk material

functional group of this RPSTL. Part numbers for bulk material are also referenced in the Description Column of the line item entry for the item to be manufactured/fabricated. Detailed fabrication instructions for items source coded to be manufactured or fabricated are found in this technical manual.

Index Numbers. Items which have the word BULK in the figure column will have an index number shown in the item number column. This index number is a cross-reference between the NSN / P/N index work packages and the bulk material list in the repair parts list work package.

Illustrations List. The illustrations in this RPSTL contain unit authorized items. Illustrations published in this TM that contain unit authorized items also appear in this RPSTL. The tabular list in the repair parts list work package contains only those parts coded "O" in the third position of the SMR code, therefore, there may be a break in the item number sequence.

HOW TO LOCATE REPAIR PARTS

1. When NSNs or P/Ns Are Not known.

First. Using the table of contents, determine the assembly group to which the item belongs. This is necessary since figures are prepared for assembly groups and subassembly groups, and lists are divided into the same groups.

Second. Find the figure covering the functional group or subfunctional group to which the item belongs.

Third. Identify the item on the figure and note the number(s).

Fourth. Look in the repair parts list work packages for the figure and item numbers. The NSNs and part numbers are on the same line as the associated item numbers.

2. When NSN is Known.

First, if you have the NSN, look in the STOCK NUMBER column of the NSN index work package. The NSN is arranged in NIIN sequence. Note the figure and item number next to the NSN.

Second. Turn to the figure and locate the item number. Verify that the item is the one you are looking for.

3. When P/N is Known.

First. If you have the P/N and not the NSN, look in the PART NUMBER column of the P/N index work package. Identify the figure and item number.

Second. Look up the item on the figure in the applicable repair parts list work package.

OPERATOR, FIELD AND SUSTAINMENT MAINTENANCE

LARGE CAPACITY FIELD HEATER (LCFH)

ASSEMBLY, HEATER
40000

REPAIR PARTS LIST

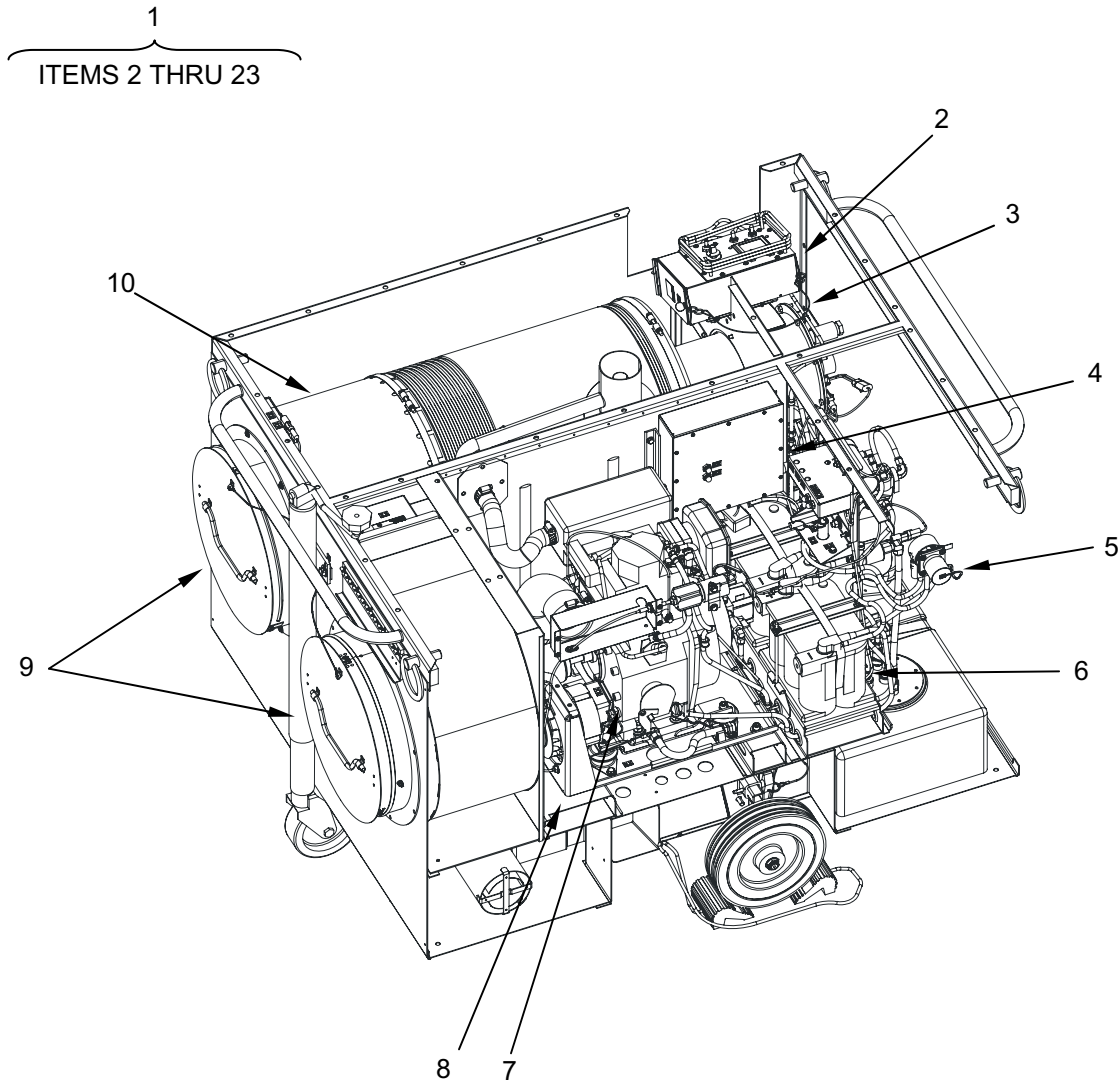

Top View

Figure 1. Large Capacity Field Heater (LCFH) (Sheet 1 of 4).

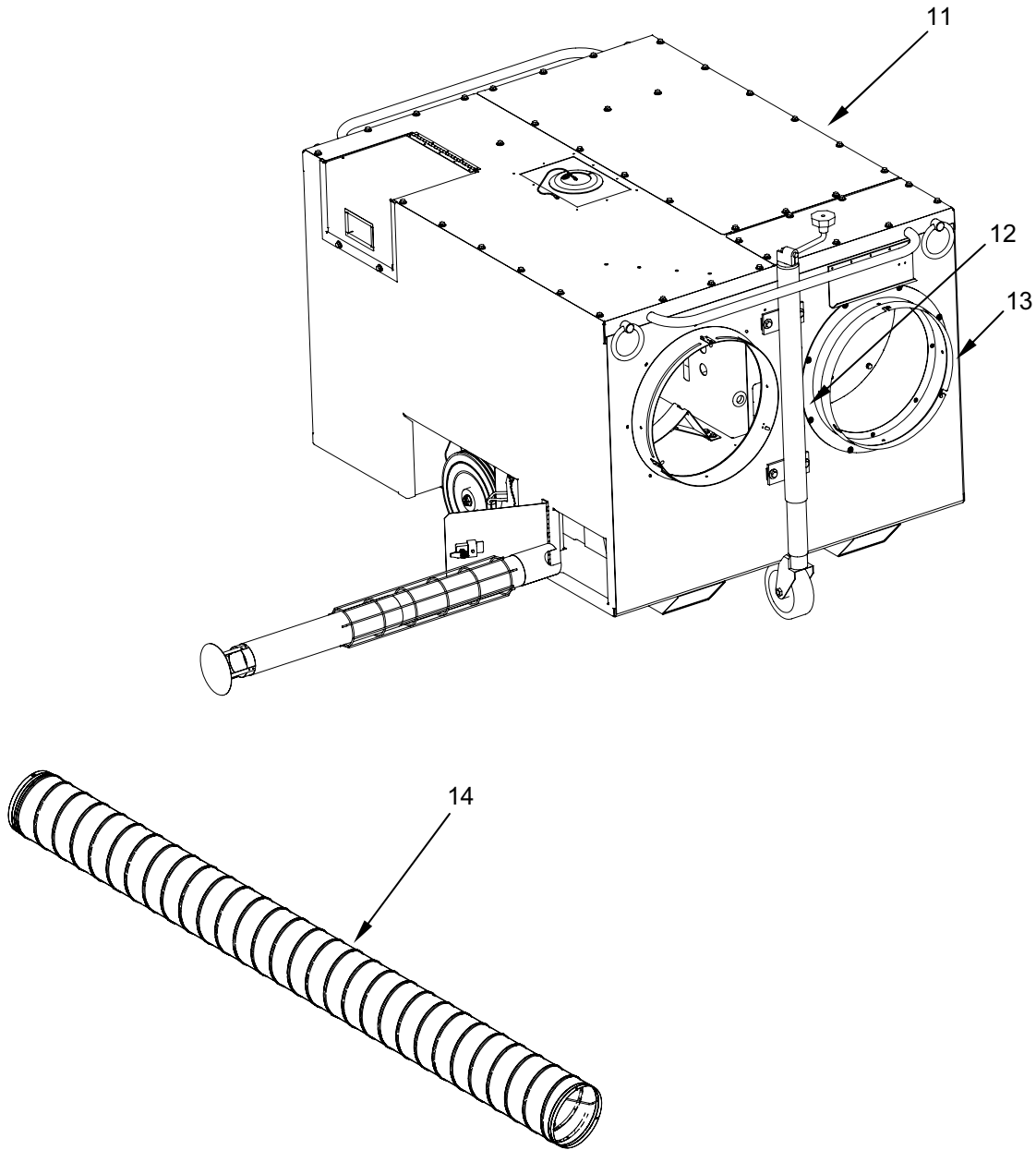

Front View
Figure 1. Large Capacity Field Heater (LCFH) (Sheet 2 of 4).
0094 00-2

Change 1

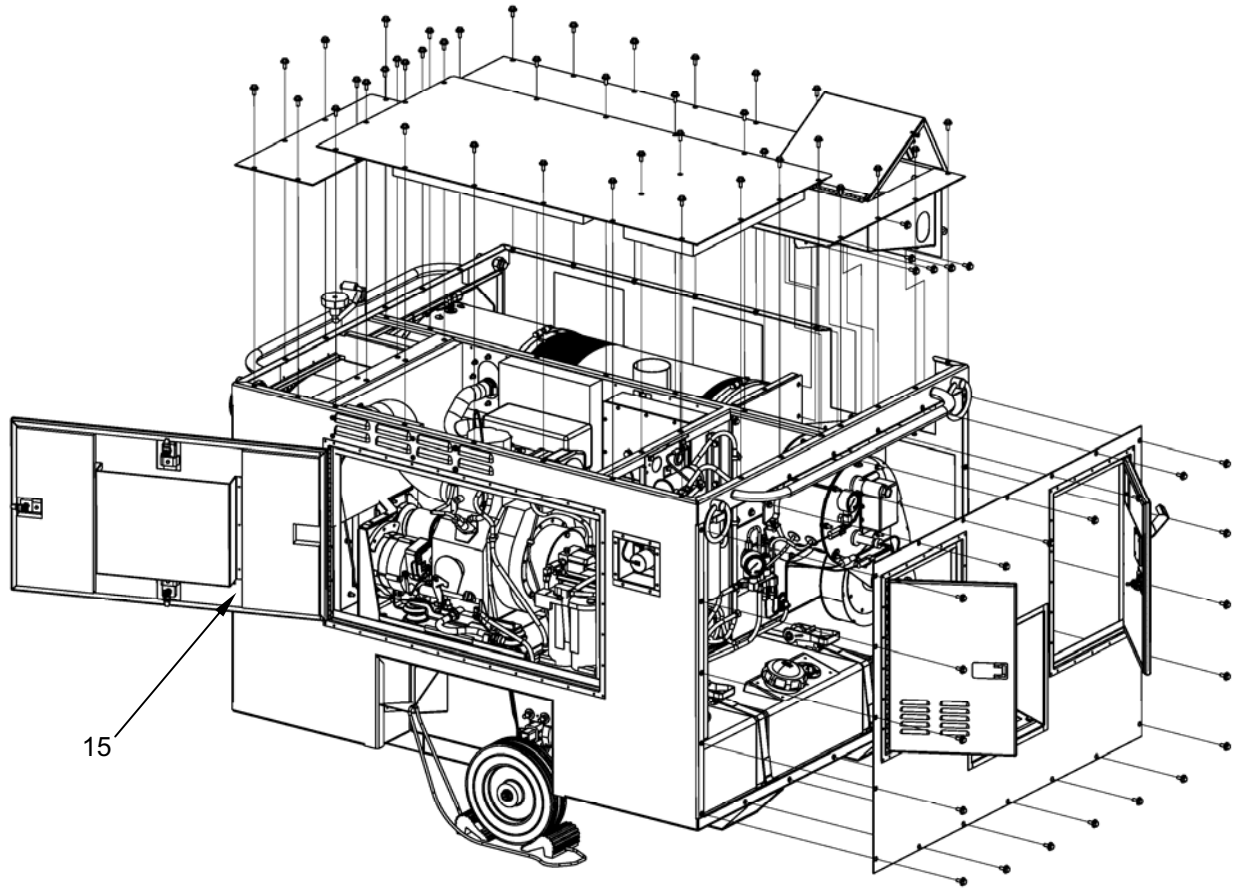

Roadside View

Figure 1. Large Capacity Field Heater (LCFH) (Sheet 3 of 4).

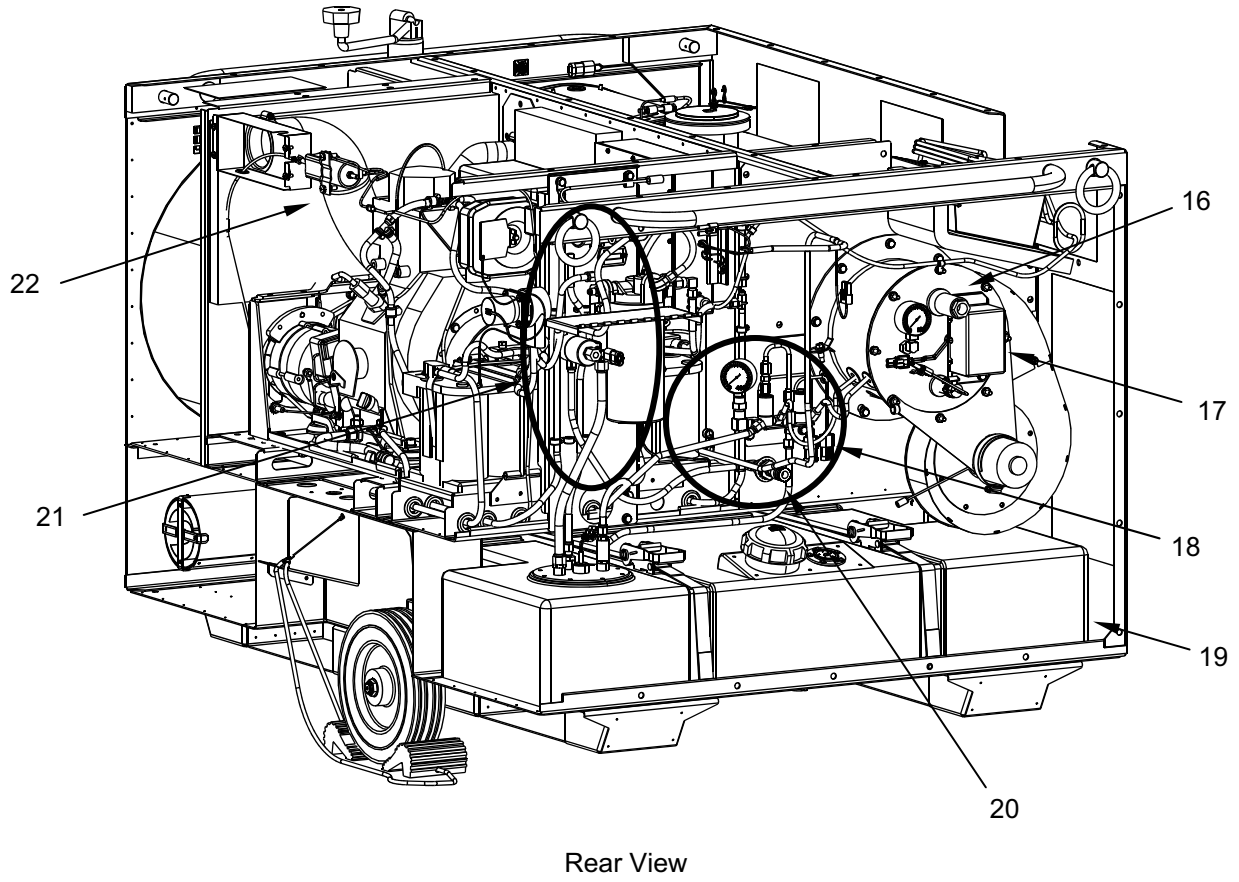

Rear View

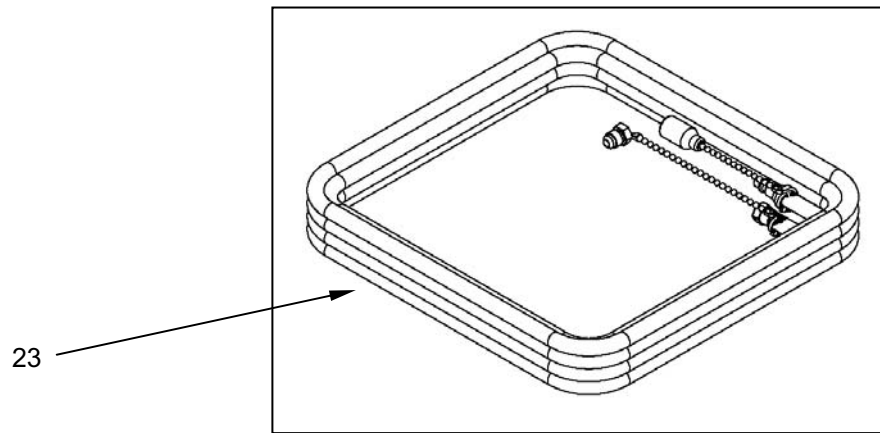

Figure 1. Large Capacity Field Heater (LCFH) (Sheet 4 of 4).

(1)	(2)	(3)	(4)	(5)	(6)	(7)
ITEM NO	SMR CODE	NATIONAL STOCK NUMBER	CAGEC	PART NUMBER	DESCRIPTION AND USABLE ON CODE (UOC)	QTY
					GROUP 00	
					FIG. 1 LARGE CAPACITY FIELD HEATER (LCFH)	
1	PAOHH	4520-01-500-1534	92878	40000	LARGE CAPACITY FIELD HEATER (LCFH).....	1
2	PAOOO	4520-01-539-7164	92878	40405	● ASSEMBLY, OPERATOR CONTROL BOX (SEE FIGURE 18, SHEET 1 OF 2 FOR PARTS BREAKDOWN)	1
3	XDOZZ		92878	40370	● HEAT EXCHANGER (SEE FIGURE 13 FOR PARTS BREAKDOWN)	1
4	PAOKK	4520-01-539-7167	92878	40401	● ASSEMBLY, MAIN CONTROL BOX (SEE FIGURE 17 FOR PARTS BREAKDOWN).....	1
5	PAOZZ	5935-01-097-9974	0FW39	11674728	● NATO SLAVE CONNECTOR (SEE FIGURE 16 FOR PARTS BREAKDOWN) .	1
6	PCOZZ	6140-01-475-9361	OUJ55	75/35	● BATTERY (SEE FIGURE 15 FOR PARTS BREAKDOWN).....	1
7	PAFHH	2815-01-539-8274	92878	40101	● ENGINE, DIESEL (SEE FIGURE 9 FOR PARTS BREAKDOWN)	1
8	XDOOO		92878	40100	● ASSEMBLY, ENGINE SYSTEM (SEE FIGURE 8 FOR PARTS BREAKDOWN) ...	1
9	XDOZZ		92878	40514	● DUCT COVERS (SEE FIGURE 20 FOR PARTS BREAKDOWN)	2
10	XDOOO		92878	40303	● ASSEMBLY, TRANSITION TUBE (SEE FIGURE 14 FOR PARTS BREAKDOWN).....	1
11	XCOOO		92878	40050	● ASSEMBLY, CABINET (SEE FIGURE 2 FOR PARTS BREAKDOWN)	1
12	PAOZZ	4520-01-539-7184	92878	40510	● ● ASSEMBLY, JACK (SEE FIGURE 2 FOR PARTS BREAKDOWN)	1
13	XDOZZ		92878	40185	● INLET FAN (SEE FIGURE 7 FOR PARTS BREAKDOWN).....	1
14	PAOZZ	4720-01-539-7168	92878	40700	● AIR DUCT, INSULATED, 16 IN DIA X 15 FT LONG (SEE FIGURE 19 FOR PARTS BREAKDOWN).....	2
15	XCOOO		92878	40050	● INSULATION, SHEET SOUND (SEE FIGURE 3 FOR PARTS BREAKDOWN) ...	1
16	XDOOO		92878	40035	● BURNER ASSEMBLY (SEE FIGURE 13 FOR PARTS BREAKDOWN)	1
17	XDOOO		92878	40304	● ASSEMBLY, IGNITION (SEE FIGURE 11 FOR PARTS BREAKDOWN)	1
18	XDOOO		92878	40208	● ASSEMBLY, FUEL VALVES, BURNER (SEE FIGURE 5 FOR PARTS BREAKDOWN).....	1
19	XDOOO		92878	40508	● FUEL TANK (SEE FIGURE 6 FOR PARTS BREAKDOWN).....	1
20	XCOOO		92878	40302-02	● ASSEMBLY, BURNER NOZZLE (SEE FIGURE 12 FOR PARTS BREAKDOWN) .	1
21	XCOOO		92878	40202	● ASSEMBLY, PANEL, FUEL (SEE FIGURE 4 FOR PARTS BREAKDOWN) ...	1

(1)	(2)	(3)	(4)	(5)	(6)	(7)
ITEM NO	SMR CODE	NATIONAL STOCK NUMBER	CAGEC	PART NUMBER	DESCRIPTION AND USABLE ON CODE (UOC)	QTY
22	PAOZZ	5945-01-539-8273	92878	40139	• SOLENOID, ENGINE SHUTDOWN (SEE FIGURE 8 FOR PARTS BREAKDOWN).....	1
23	PAOOO	4720-01-540-3595	92878	40702	• ASSEMBLY, EXTERNAL FUEL HOSE (SEE FIGURE 6 FOR PARTS BREAKDOWN).....	1
END OF FIGURE						

**OPERATOR, FIELD AND SUSTAINMENT MAINTENANCE
LARGE CAPACITY FIELD HEATER (LCFH)
ASSEMBLY, CABINET
40050
REPAIR PARTS LIST**

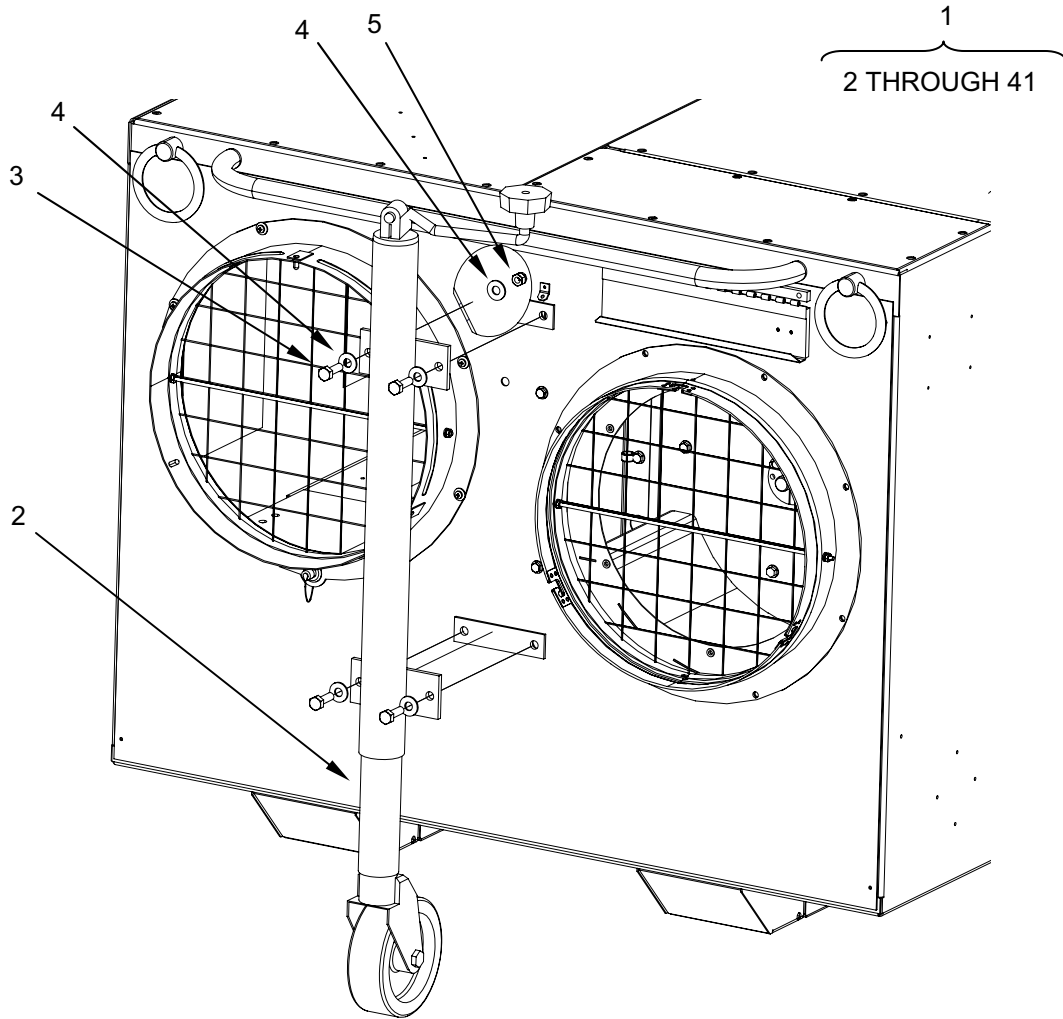

Figure 2. Assembly, Jack (Sheet 1 of 6).

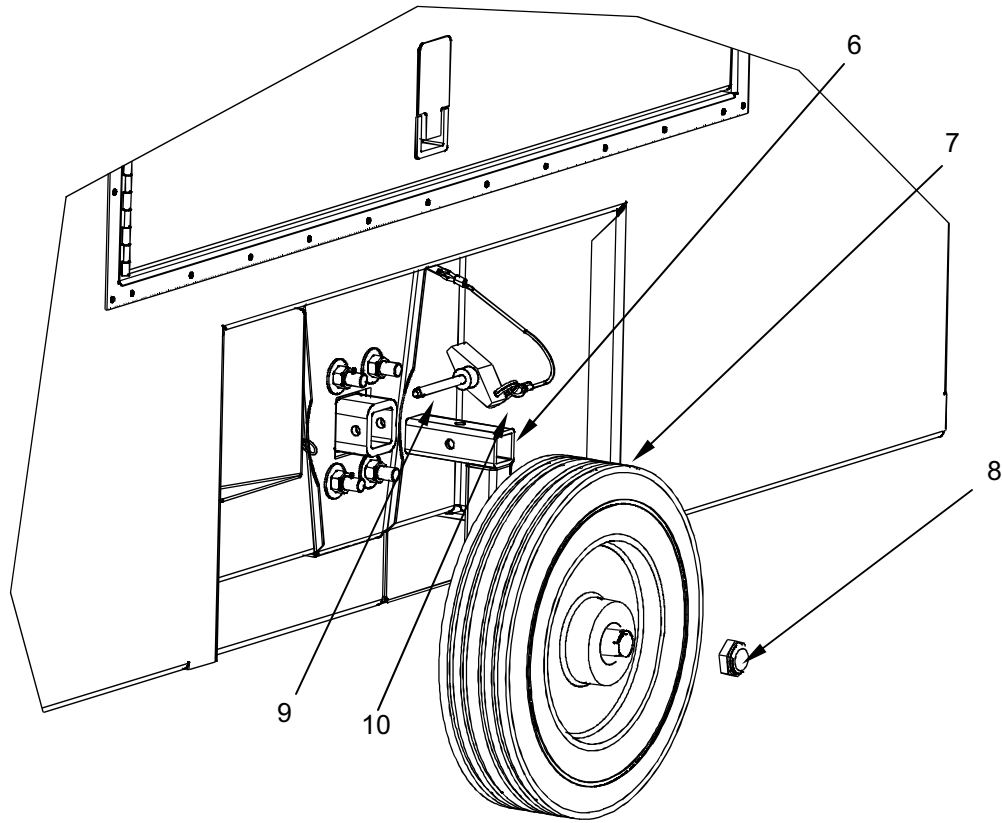

Figure 2. Installation, Wheel Retraction Assembly (Sheet 2 of 6).

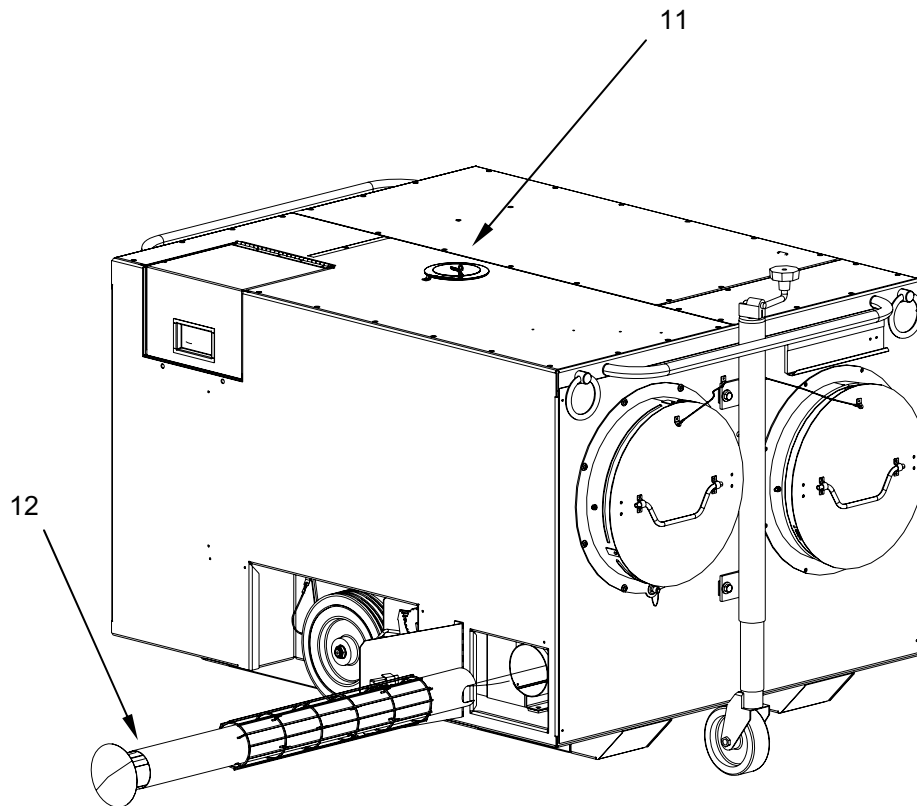

Figure 2. Exhaust Tube, Heat Exchanger (Sheet 3 of 6).

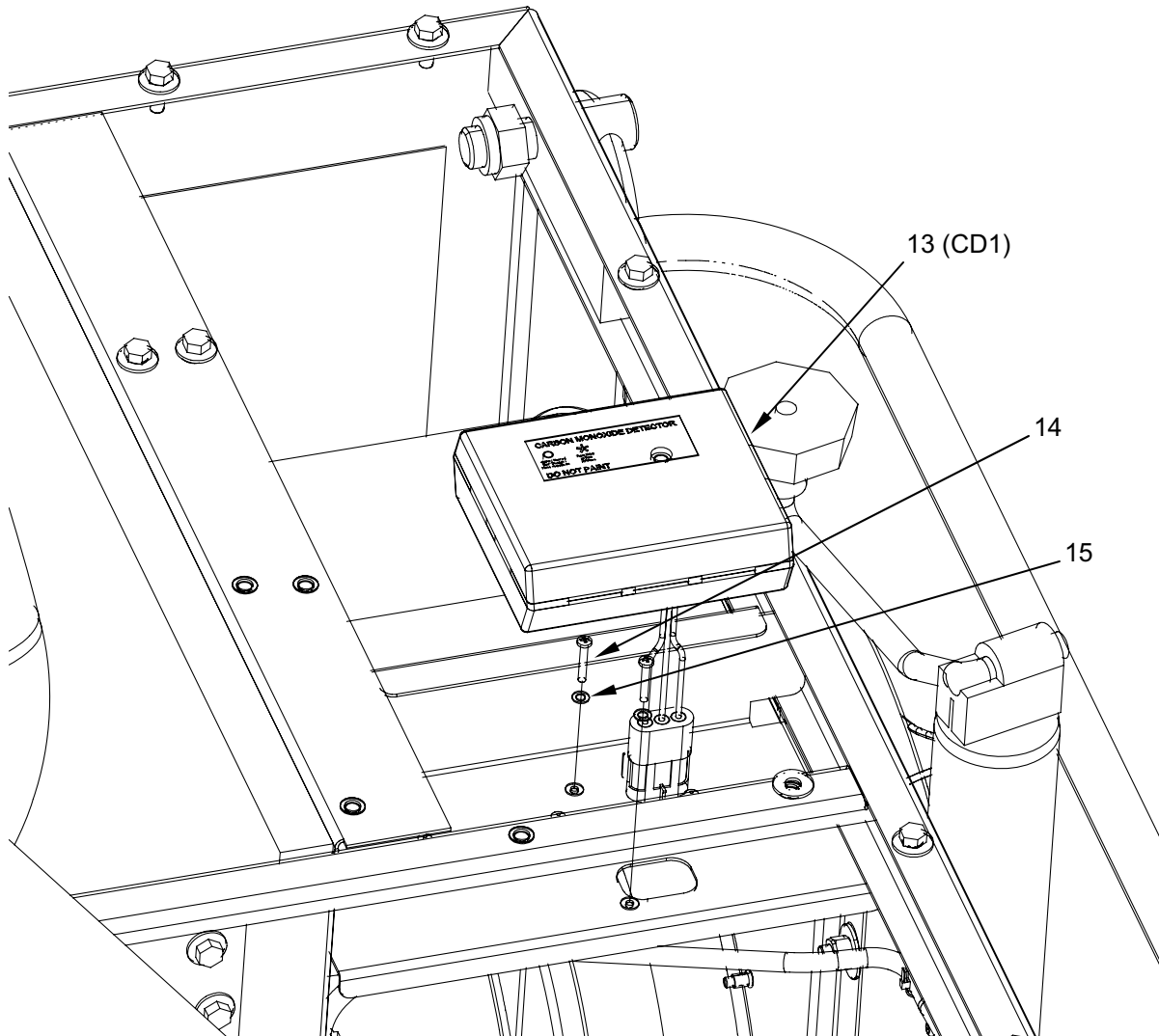

Figure 2. CO Detector, Cabinet Mounted (Sheet 4 of 6).

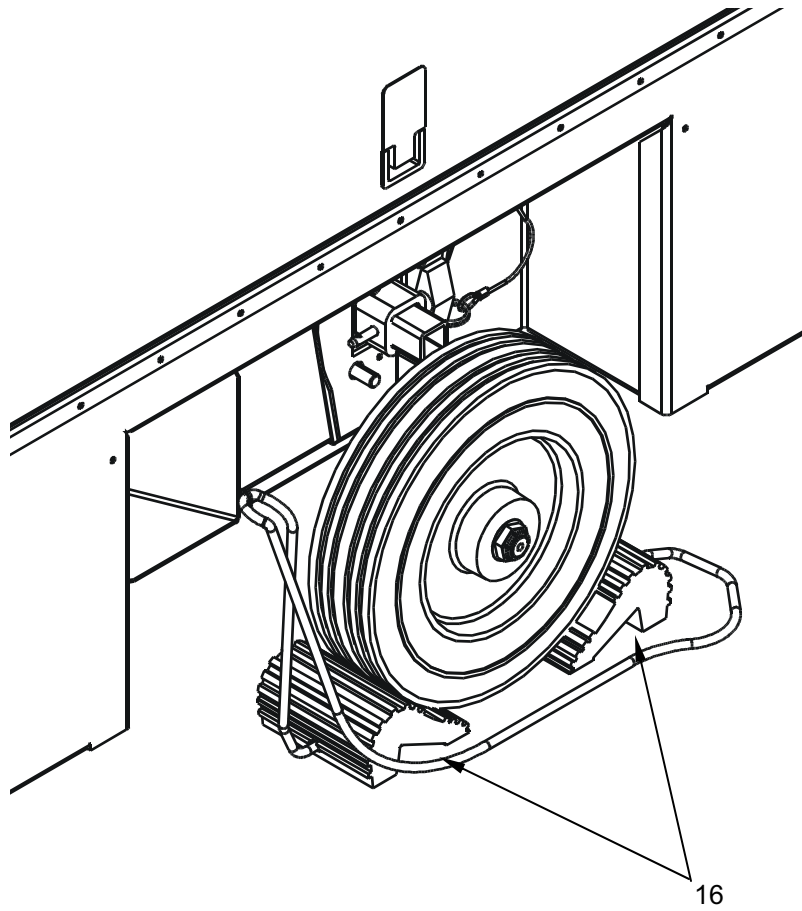

Figure 2. Wheel Chock Assembly (Sheet 5 of 6).

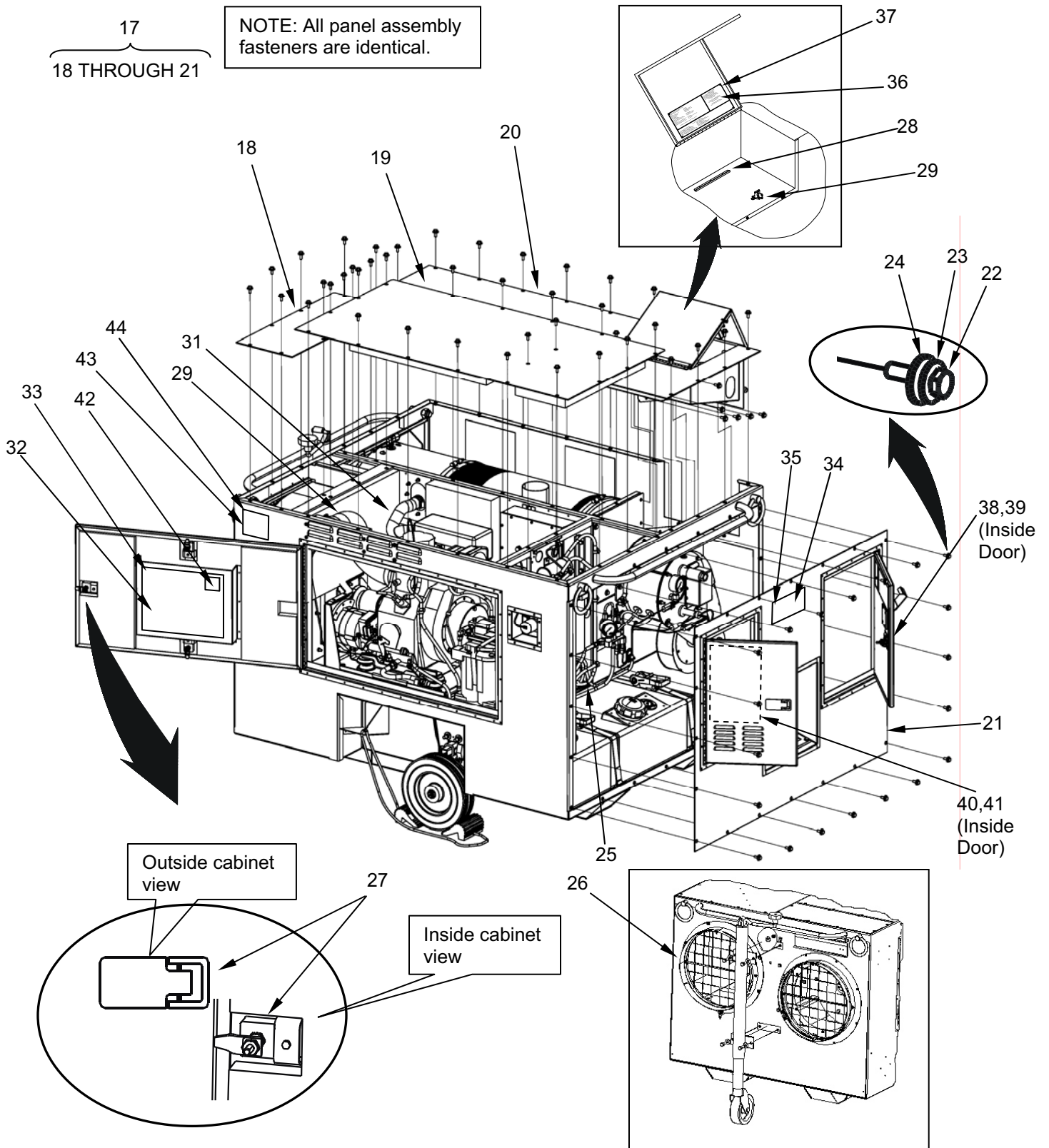

Figure 2. Access Covers (Sheet 6 of 6).

(1)	(2)	(3)	(4)	(5)	(6)	(7)
ITEM NO	SMR CODE	NATIONAL STOCK NUMBER	CAGEC	PART NUMBER	DESCRIPTION AND USABLE ON CODE (UOC)	QTY
GROUP 01						
FIG. 2 ASSEMBLY, CABINET						
1	XCOOO		92878	40050	ASSEMBLY, CABINET	1
2	PAOZZ	4520-01-539-7184	92878	40510	● ASSEMBLY, JACK	1
3	PAOZZ	5305-00-068-0511	80204	B1821BH038C1	● SCREW, CAP, HEXAGON	
4	PAOZZ	5310-00-809-4061	45152	110380A	HEAD.....	4
5	PAOZZ	5310-00-087-4652	27687	F51N7582-616	● WASHER, FLAT	8
6	PAOOO	4520-01-539-7186	92878	40502	● NUT, SELF-LOCKING, HEX.....	4
7	XDOZZ		92878	40520	● WHEEL RETRACTION ASSEMBLY	2
8	XDOZZ		0E328	94830A560	● ● WHEEL, SOLID RUBBER TIRE	2
9	PAOZZ	5315-01-481-2030	4X630	863-000553	● ● NUT, LOCK	2
10	XDOZZ		92878	40528	● PIN, QUICK RELEASE.....	2
11	PAOZZ	2990-01-539-7187	92878	40586	● ● WIRE ROPE ASSEMBLY SET	2
12	PAOZZ	4520-01-539-7188	92878	40505	● CAP ASSEMBLY, PROTECTIVE, MUFFLER-EXHAUST PIPE.....	1
13	PCOZZ	6665-01-539-8270	92878	40489	● PIPE EXHAUST	1
14	PAOZZ	5305-00-984-4984	80205	MS35206-227	● INDICATOR, CARBON MONOXIDE	1
15	PAOZZ	5310-00-809-8544	80063	MS27183-7	● SCREW, MACHINE.....	2
16	PAOZZ	2540-01-539-8271	92878	40507	● WASHER, FLAT	2
17	XCOOO		92878	40501	● CHOCK, WHEEL-TRACK ASSEMBLY ..	2
18	XDOZZ		92878	75056-100	● HOUSING.....	1
19	XDOZZ		92878	75012-100	● ● COVER, ACCESS	1
20	XDOZZ		92878	75011-100	● ● COVER, ACCESS	1
21	XDOZZ		92878	75005-100	● ● COVER, ACCESS	1
22	PAOZZ	5305-00-068-0502	00365	F98	● SCREW, CAP, HEXAGON HEAD	60
23	PAOZZ	5310-00-582-5965	99539	CBM21389	● WASHER, LOCK	60
24	PAOZZ	5310-01-274-3255	96906	MS27183-52	● WASHER, FLAT	60
25	MOOZZ		92878	40196	● MOULDING, PLASTIC (MAKE FROM BULK P/N 8451A53 CAGEC 0E328).....	3
26	XDOZZ		92878	40517	● AIR OUTLET	1
27	PAOZZ	5340-01-479-5255	94222	62-40-151-3	● CATCH, FRICTION	6
28	XDOZZ		92878	40432	● BRACKET, MOUNTING, OPERATOR BOX	1
29	PAOZZ	5340-01-467-7561	94222	K3-1735-52	● CATCH, CLAMPING	1
30	PAOZZ	4720-01-539-7189	92878	40566	● FLEXIBLE COOLING DUCT	1
31	PAOZZ	2835-01-540-2887	92878	40114	● DUCT, EXHAUST, NONAIRCRAFT, GAS TURBINE	1
32	XDOZZ		92878	40041	● PLACARD, WIRING DIAGRAM.....	1
33	PAOZZ	5320-01-023-2529	54402	AD44BS	● RIVET, BLIND	4

(1)	(2)	(3)	(4)	(5)	(6)	(7)
ITEM NO	SMR CODE	NATIONAL STOCK NUMBER	CAGEC	PART NUMBER	DESCRIPTION AND USABLE ON CODE (UOC)	QTY
34	XDOZZ		92878	40022	• PLACARD, FUEL SPECIFICATION	1
35	PAOZZ	5320-01-172-5602	06888	AD42BS	• RIVET, BLIND	4
36	XDOZZ		92878	40051-01	• PLACARD, OPERATING PROCEDURES AND FAULT CODES	1
37	PAOZZ	5320-01-023-2529	54402	AD44BS	• RIVET, BLIND	4
38	XDOZZ		92878	40031	• PLACARD, BURNER COMPARTMENT.....	1
39	PAOZZ	5320-01-023-2529	54402	AD44BS	• RIVET, BLIND	4
40	XDOZZ		92878	40021	• PLACARD, FUEL SYSTEM.....	1
41	PAOZZ	5320-01-023-2529	54402	AD44BS	• RIVET, BLIND	4
42	XDOZZ		92878	40838	• LABEL, WARNING, ROTATING MACHINERY	1
43	XDOZZ		92878	40052	• PLATE, IDENTIFICATION.....	1
44	PAOZZ	5320-01-023-2529	54402	AD44BS	• RIVET, BLIND	4
END OF FIGURE						

OPERATOR, FIELD AND SUSTAINMENT MAINTENANCE

LARGE CAPACITY FIELD HEATER (LCFH)

INSULATION, SHEET SOUND

40050

REPAIR PARTS LIST

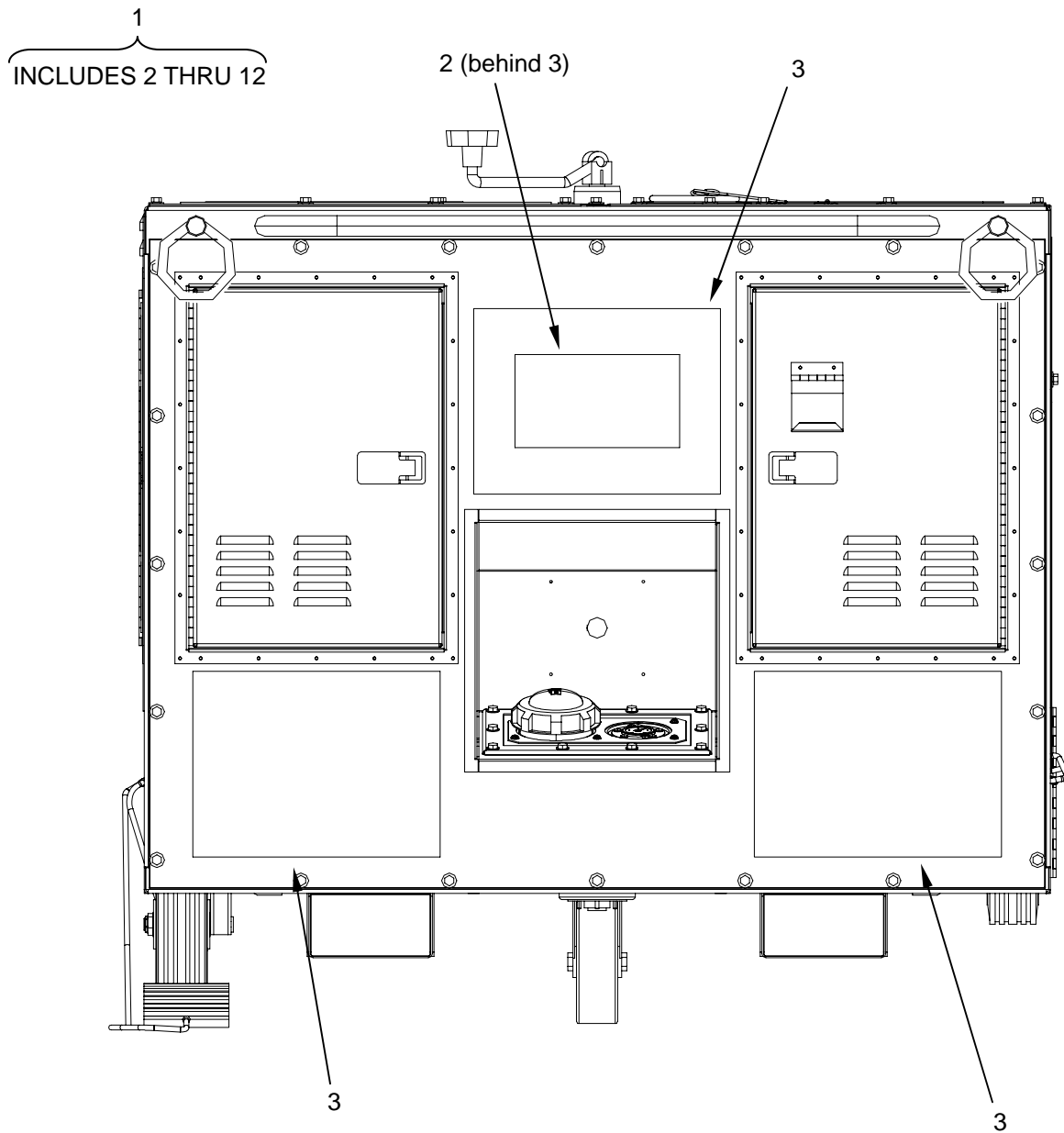

Figure 3. Insulation, Sheet Sound (Sheet 1 of 5)

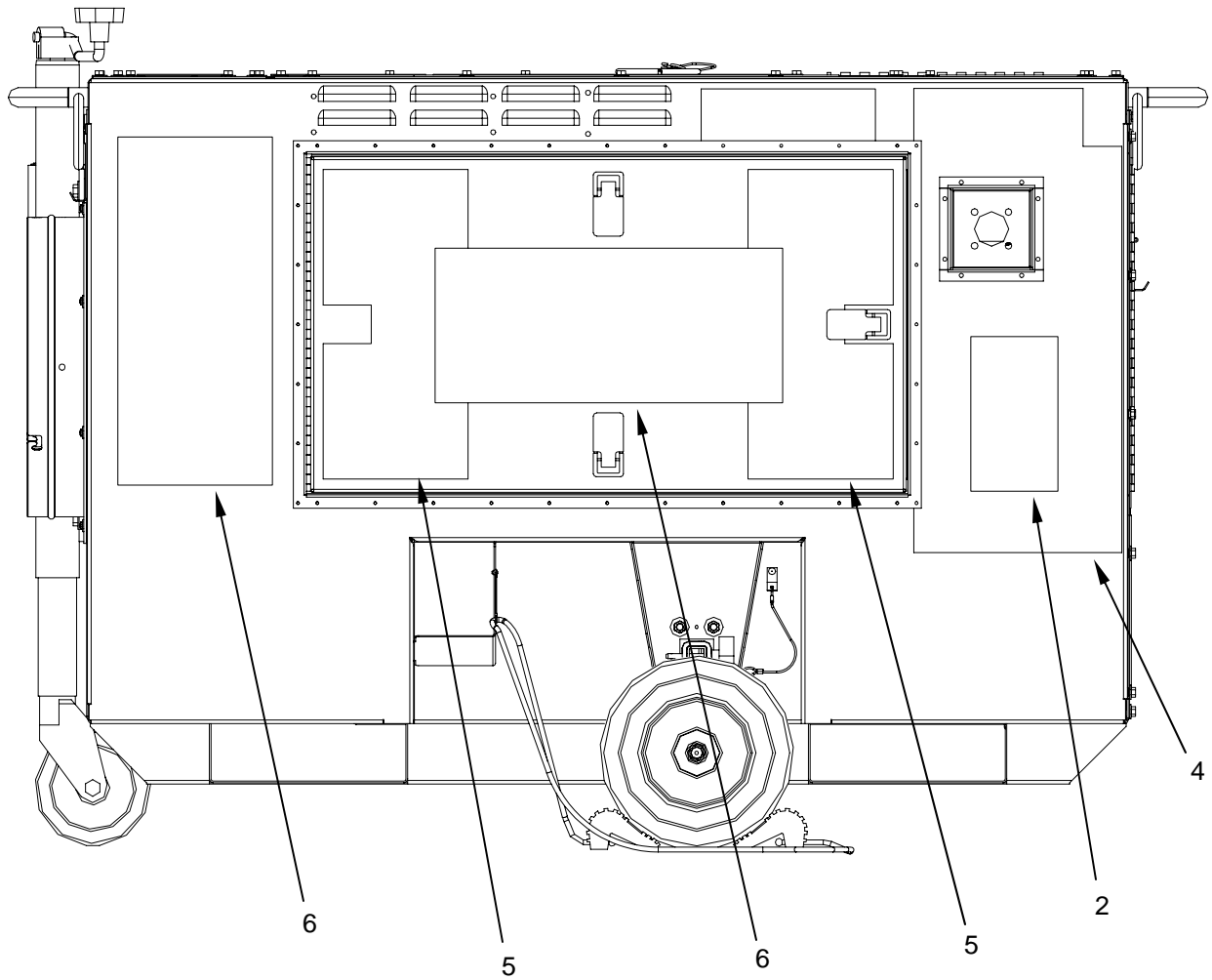

Figure 3. Insulation, Sheet Sound (Sheet 2 of 5)

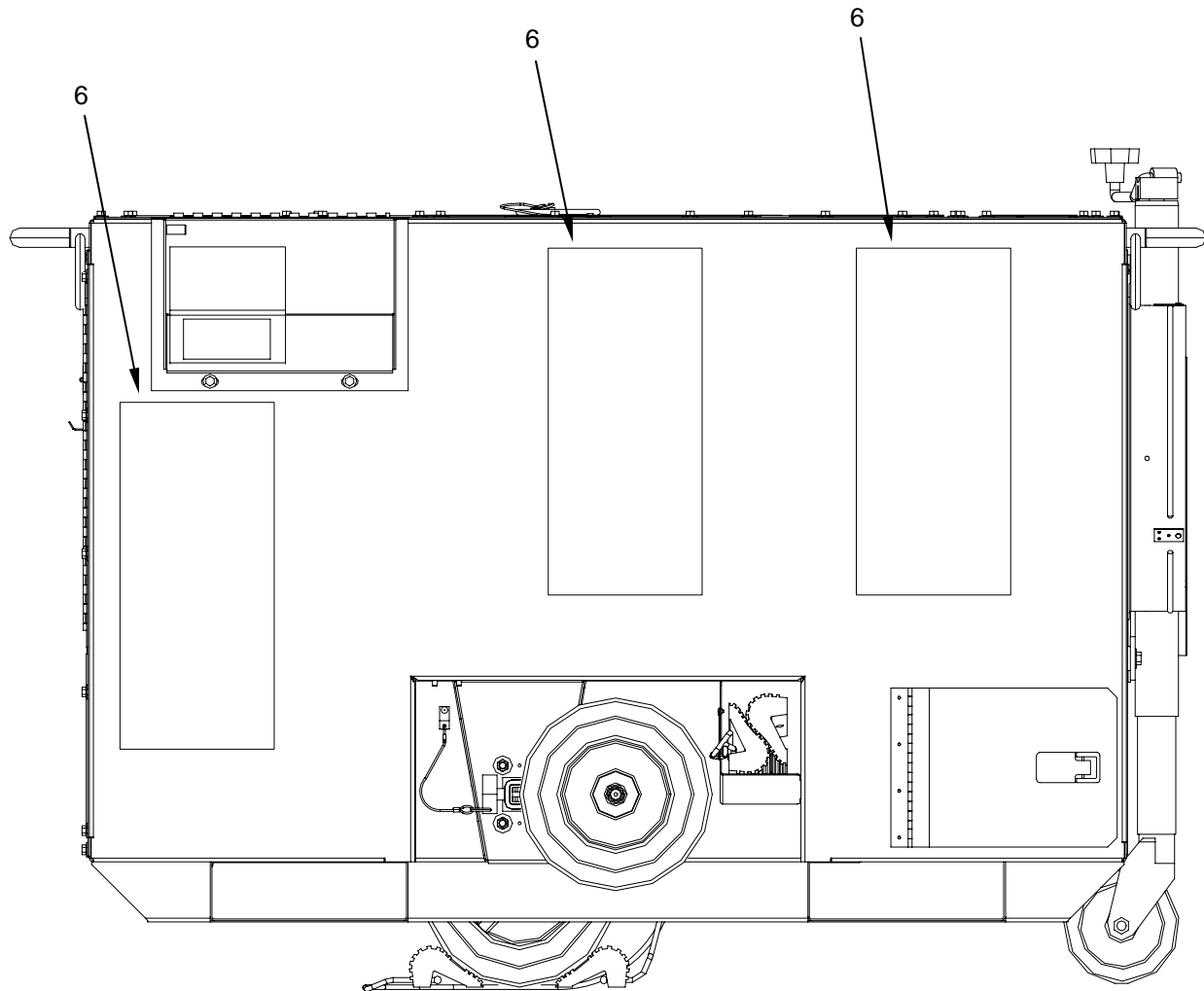

Figure 3. Insulation, Sheet Sound (Sheet 3 of 5)

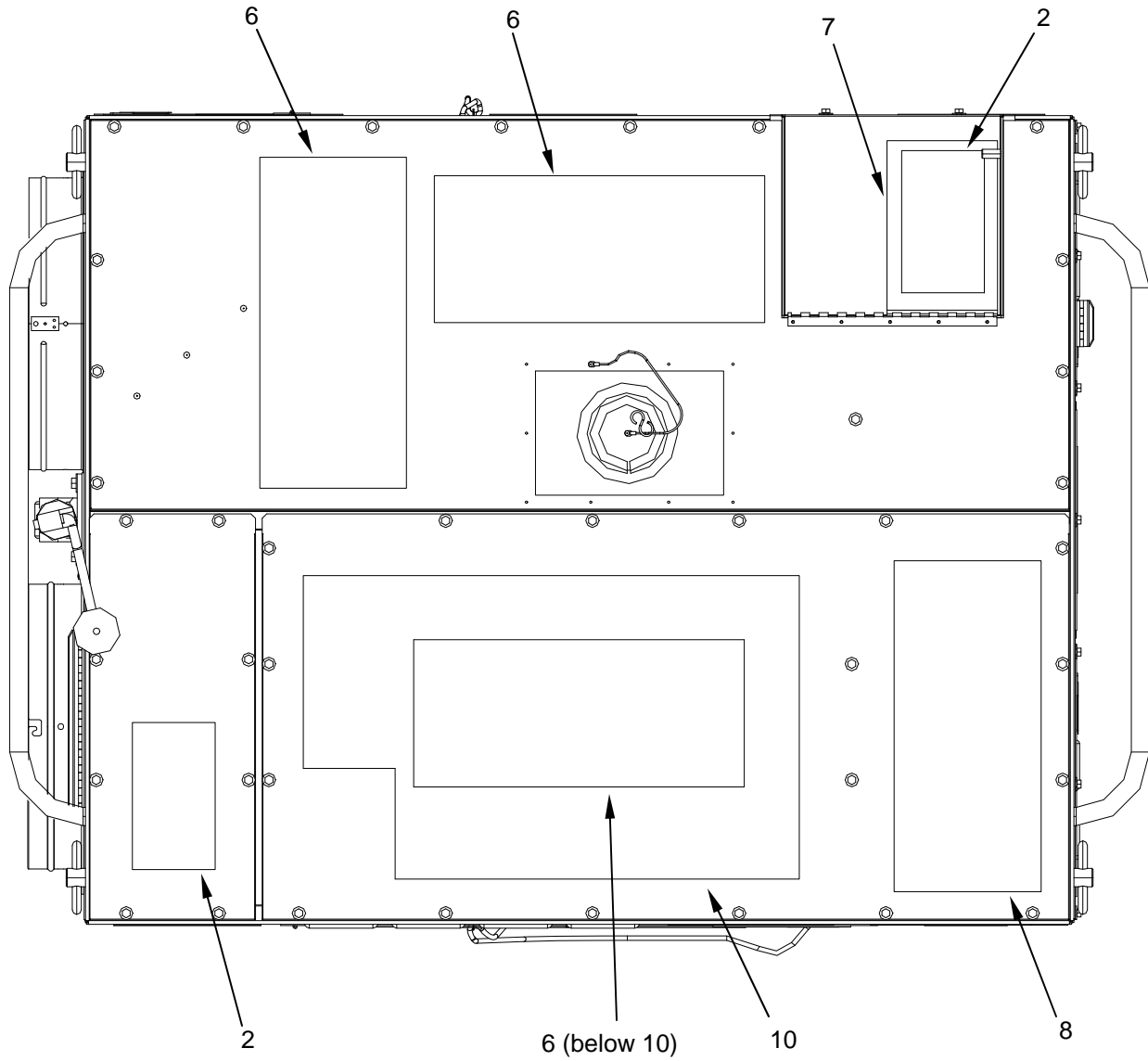

Figure 3. Insulation, Sheet Sound (Sheet 4 of 5)

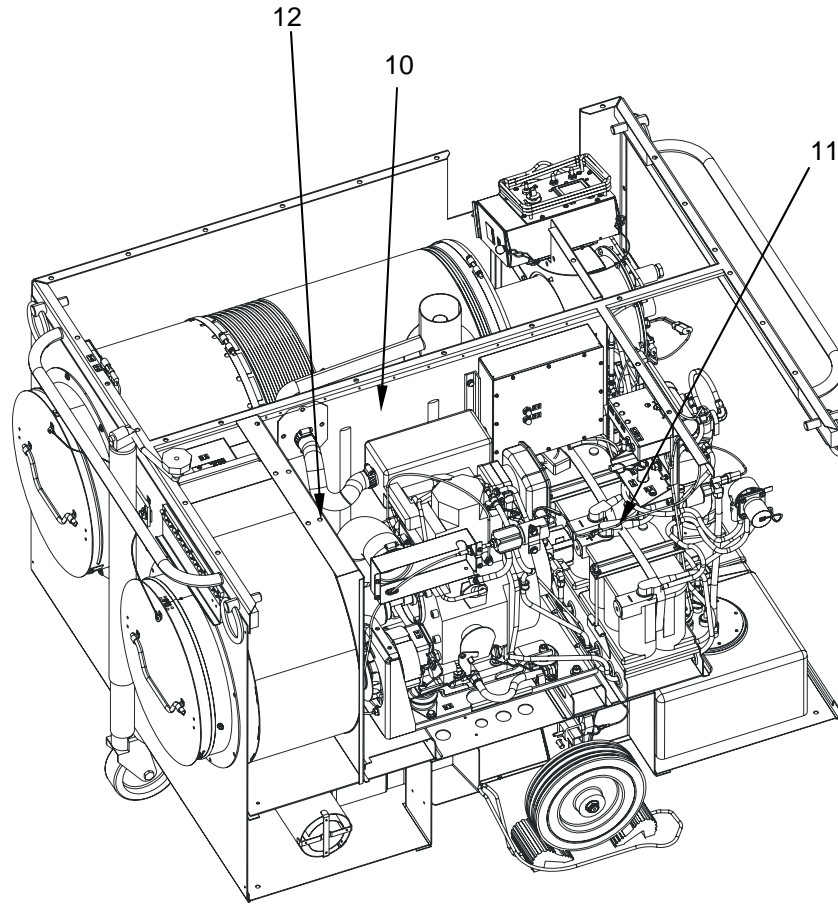

Figure 3. Insulation, Sheet Sound (Sheet 5 of 5)

(1)	(2)	(3)	(4)	(5)	(6)	(7)
ITEM NO	SMR CODE	NATIONAL STOCK NUMBER	CAGEC	PART NUMBER	DESCRIPTION AND USABLE ON CODE (UOC)	QTY
					GROUP 01	
					FIG. 3 INSULATION, SHEET SOUND	
1	XCOOO		92878	40050	ASSEMBLY, CABINET	1
2	XDOZZ		92878	40533-01	• SOUND CONTROLLING, BATT.....	4
3	XDOZZ		92878	40530-03	• SOUND CONTROLLING, BATT.....	3
4	XDOZZ		92878	40531-03	• SOUND CONTROLLING, BATT.....	3
5	XDOZZ		92878	40530-04	• SOUND CONTROLLING, BATT.....	2
6	XDOZZ		92878	40533-02	• SOUND CONTROLLING, BATT.....	7
7	XDOZZ		92878	40530-01	• SOUND CONTROLLING, BATT.....	1
8	XDOZZ		92878	40531-02	• SOUND CONTROLLING, BATT.....	1
9	XDOZZ		92878	40530-02	• SOUND CONTROLLING, BATT.....	1
10	XDOZZ		92878	40531-05	• SOUND CONTROLLING, BATT.....	1
11	XDOZZ		92878	40531-04	• SOUND CONTROLLING, BATT.....	1
12	XDOZZ		92878	40531-01	• SOUND CONTROLLING, BATT.....	1
					END OF FIGURE	

TM 9-4520-272-14&P

0097 00

OPERATOR, FIELD AND SUSTAINMENT MAINTENANCE
LARGE CAPACITY FIELD HEATER (LCFH)
FUEL SYSTEM ASSEMBLY
40202
REPAIR PARTS LIST

0097 00-1

Change 1

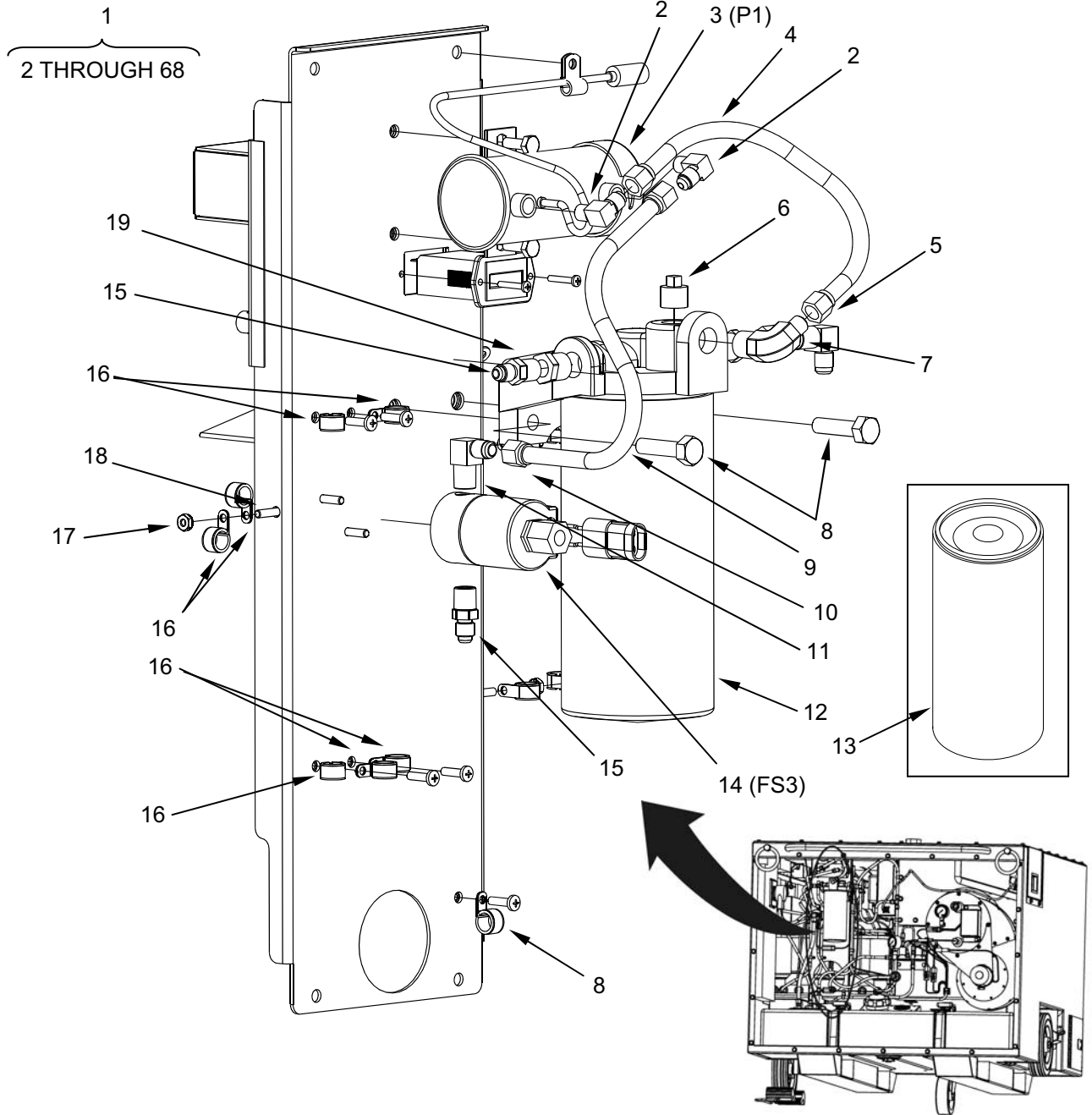

Figure 4. Fuel System Assembly (Sheet 1 of 5).

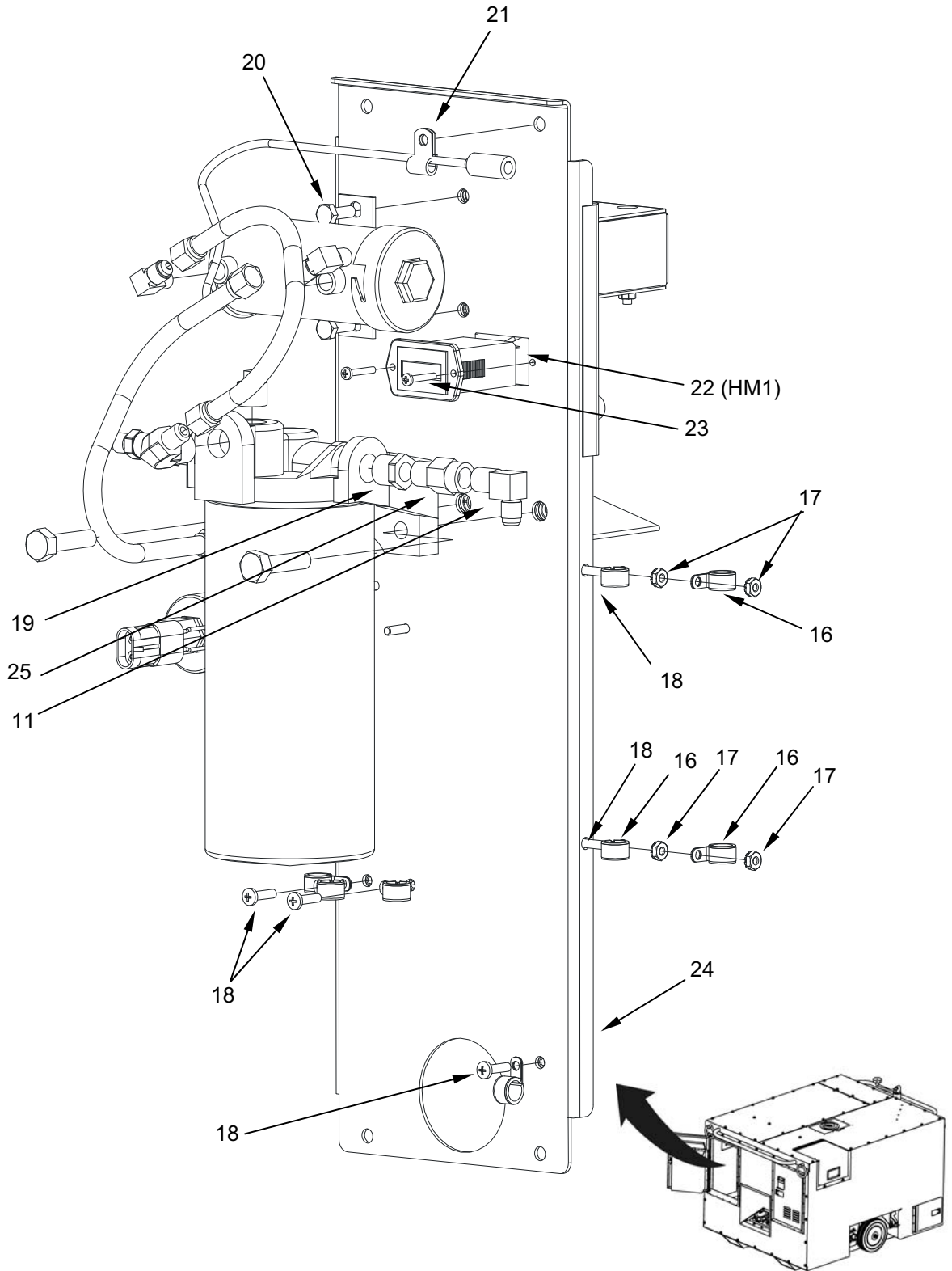

Figure 4. Fuel System Assembly (Sheet 2 of 5).

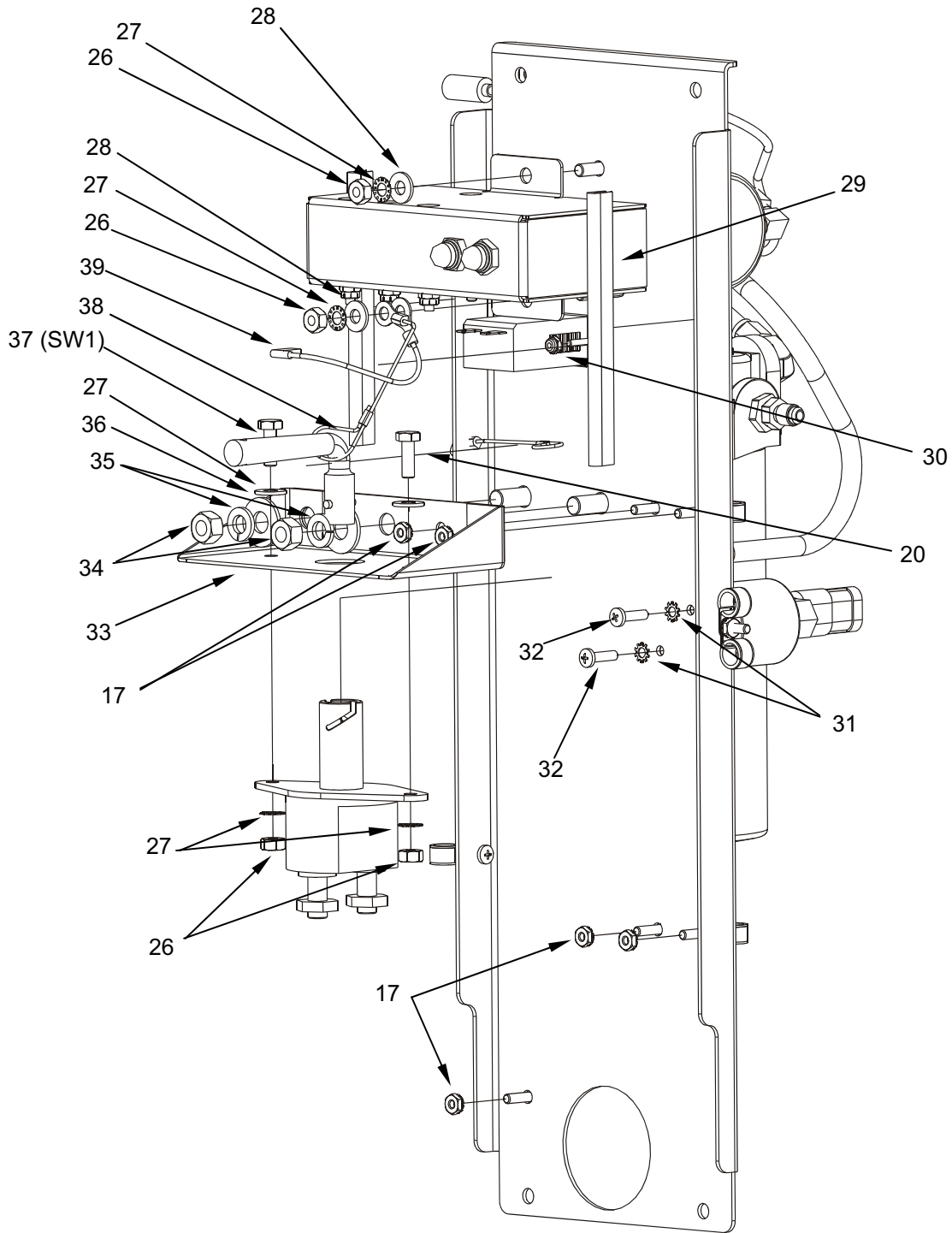

Figure 4. Fuel System Assembly (Sheet 3 of 5).

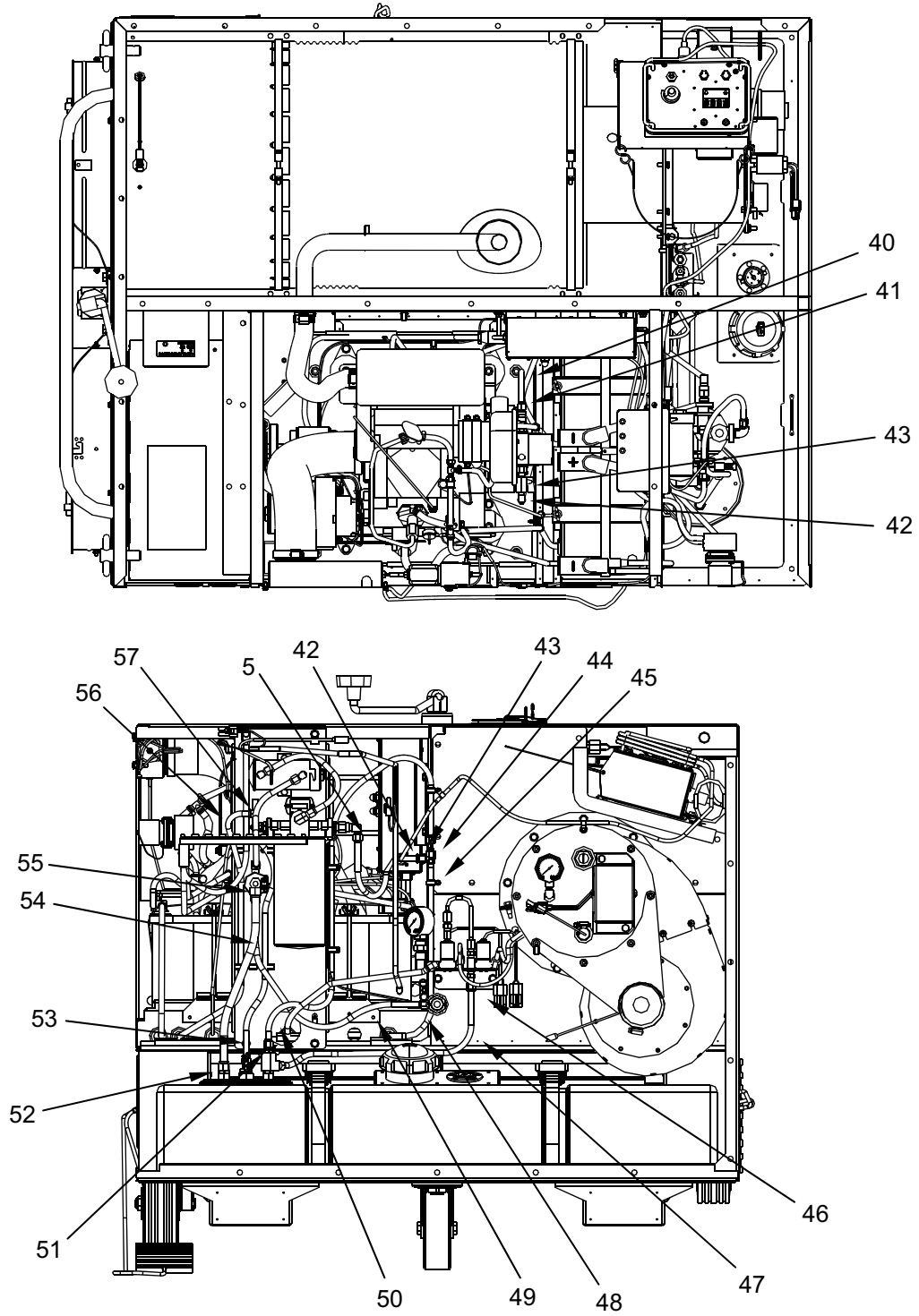

Figure 4. Fuel System Assembly (Sheet 4 of 5).

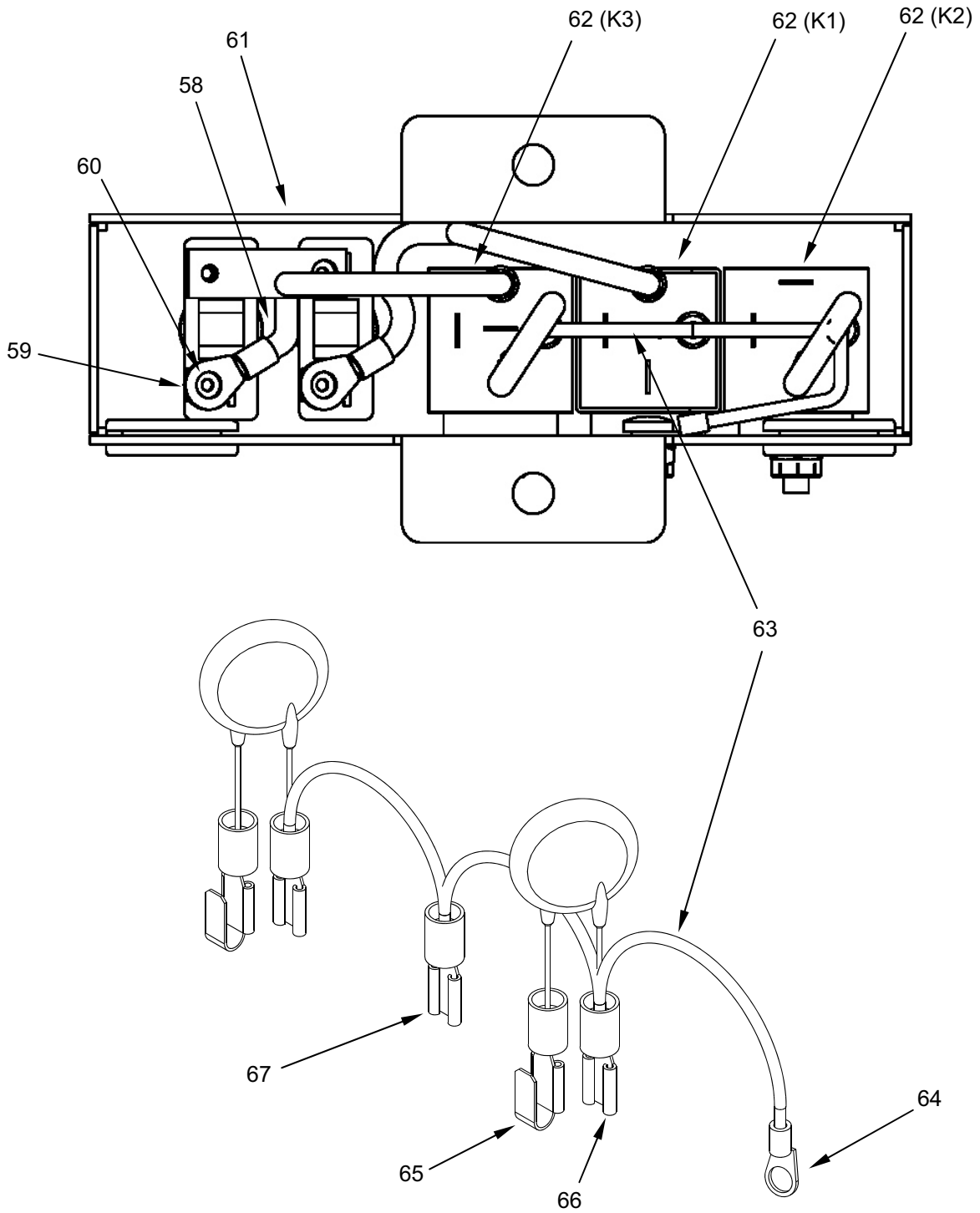

Figure 4. Fuel System Assembly (Sheet 5 of 5).

(1)	(2)	(3)	(4)	(5)	(6)	(7)
ITEM NO	SMR CODE	NATIONAL STOCK NUMBER	CAGEC	PART NUMBER	DESCRIPTION AND USABLE ON CODE (UOC)	QTY
					GROUP 02	
					FIG. 4 FUEL SYSTEM ASSEMBLY	
1	XCOOO		92878	40202	FUEL SYSTEM ASSEMBLY	1
2	PAOZZ	4730-00-254-6211	81343	J5124-2010202B	• ELBOW, PIPE TO TUBE	2
3	PAOZZ	2910-01-539-7197	92878	40221	• PUMP, FUEL, METERING AND DISTRIBUTING	1
4	XDOOO		92878	40224	• HOSE ASSEMBLY, NONMETALLIC.....	1
5	PAOZZ	4730-00-555-1152	70281	2203B510	• • ADAPTER, STRAIGHT, TUBE TO HOSE	2
6	XDOZZ		39428	50785K253	• PLUG, MACHINE THREAD	1
7	PAOZZ	4730-00-235-1482	93061	249-F-4-6	• ELBOW, PIPE TO TUBE	1
8	PAOZZ	5305-01-325-8387	96906	MS90725-64	• SCREW, CAP, HEXAGON HEAD	2
9	XDOOO		92878	40198	• HOSE ASSEMBLY, NONMETALLIC.....	1
10	PAOZZ	4730-00-555-1152	70281	2203B510	• • ADAPTER, STRAIGHT, TUBE TO HOSE	2
11	PAOZZ	4730-00-366-3011	79470	49X4X4	• ELBOW, PIPE TO TUBE	2
12	XDOZZ		12658	FB1301	• FILTER BODY, FLUID.....	1
13	PAOZZ	2910-01-025-6853	12658	BF-5800	• FILTER ELEMENT, FLUID.....	1
14	PAOZZ	4810-01-539-7199	92878	40223	• VALVE ASSEMBLY, MANIFOLD	1
15	PAOZZ	4730-00-723-5549	29215	JD659	• ADAPTER, STRAIGHT, PIPE TO TUBE	2
16	PAOZZ	5340-00-598-0597	81343	AS21919DG8	• CLAMP, LOOP HOSE	12
17	XDOZZ		39428	90675A011	• NUT, SELF-LOCKING, EXTENDED WASHER, HEXAGON	10
18	PAOZZ	5305-00-984-6212	80205	MS35206-265	• SCREW, MACHINE.....	8
19	PAOZZ	4730-00-202-6491	01276	3220X6X4	• BUSHING, PIPE	2
20	PAOZZ	5305-00-068-0502	96906	MS90725-6	• SCREW, CAP, HEXAGON HEAD	4
21	PAOZZ	5340-00-809-1490	80205	MS21333-98	• CLAMP, LOOP	1
22	PAOZZ	4520-01-493-2780	92878	60384	• SHC HOUR METER.....	1
23	PAOZZ	5305-00-984-4993	96906	MS35206-233	• SCREW, MACHINE.....	2
24	XDOZZ		92878	40220	• PLATE, MOUNTING.....	1
25	XDOZZ		92878	40211	• VALVE, CHECK	1
26	PAOZZ	5310-00-761-6882	96906	MS51967-2	• NUT, PLAIN, HEX	4
27	PAOZZ	5310-00-209-0786	96906	MS35335-33	• WASHER, LOCK.....	4
28	PAOZZ	5310-00-809-4058	96906	MS27183-10	• WASHER, FLAT	4
29	MOOZZ		92878	40196	• MOLDING, PLASTIC (MAKE FROM BULK P/N 8451A53, CAGEC 0E328).....	2
30	PAOZZ	5310-00-081-8087	96906	MS21044N06	• NUT, SELF-LOCKING, HEXAGON	2
31	PAOZZ	5310-00-596-7691	96906	MS35335-32	• WASHER, LOCK.....	2
32	PAOZZ	5305-00-989-7435	80205	MS35207-264	• SCREW, MACHINE.....	2

(1) ITEM NO	(2) SMR CODE	(3) NATIONAL STOCK NUMBER	(4) CAGEC	(5) PART NUMBER	(6) DESCRIPTION AND USABLE ON CODE (UOC)	(7) QTY
33	XDOZZ		92878	40661	• BRACKET, MOUNTING	1
34	PAOZZ	5310-00-732-0558	96906	MS51967-8	• NUT, PLAIN, HEXAGON.....	2
35	PAOZZ	5310-00-637-9541	80205	MS35338-46	• WASHER, LOCK.....	2
36	PAOZZ	5310-00-809-4061	96906	MS27183-15	• WASHER, FLAT	2
37	PAOZZ	5930-01-485-9200	1CW22	62471	• SWITCH, ROTARY	1
38	XDOZZ		92878	40662	• WIRE ROPE ASSEMBLY, SINGLE LEG	1
39	XDOZZ		92878	40202-01	• WIRE, ELECTRICAL GROUNDING.....	1
40	XDOOO		92878	40262	• HOSE ASSEMBLY, NONMETALLIC.....	2
41	PAOZZ	4730-00-555-1152	70281	2203B510	• • ADAPTER, STRAIGHT, TUBE TO HOSE	2
42	XDOOO		92878	40261	• HOSE ASSEMBLY, NONMETALLIC.....	1
43	PAOZZ	4730-00-555-1152	70281	2203B510	• • ADAPTER, STRAIGHT, TUBE TO HOSE	2
44	PAOZZ	4730-00-555-1152	70281	2203B510	• • ADAPTER, STRAIGHT, TUBE TO HOSE	2
45	XDOOO		92878	40279	• HOSE ASSEMBLY, NONMETALLIC.....	1
46	PAOZZ	4730-00-555-1152	70281	2203B510	• • ADAPTER, STRAIGHT, TUBE TO HOSE	2
47	XDOOO		92878	40264	• HOSE ASSEMBLY, NONMETALLIC.....	1
48	PAOZZ	4730-00-555-1152	70281	2203B510	• • ADAPTER, STRAIGHT, TUBE TO HOSE	2
49	XDOOO		92878	40263	• HOSE ASSEMBLY, NONMETALLIC.....	1
50	XDOOO		92878	40265	• HOSE ASSEMBLY, NONMETALLIC.....	1
51	PAOZZ	4730-00-555-1152	70281	2203B510	• • ADAPTER, STRAIGHT, TUBE TO HOSE	2
52	PAOZZ	4730-00-588-2614	30780	30682-6-6B	• • ADAPTER, STRAIGHT, TUBE TO HOSE	2
53	XDOOO		92878	40266	• HOSE ASSEMBLY, NONMETALLIC.....	1
54	XDOOO		92878	40232	• HOSE ASSEMBLY, NONMETALLIC.....	1
55	PAOZZ	4730-00-555-1152	70281	2203B510	• • ADAPTER, STRAIGHT, TUBE TO HOSE	2
56	XDOOO		92878	40260	• HOSE ASSEMBLY, NONMETALLIC.....	1
57	PAOZZ	4730-00-555-1152	70281	2203B510	• • ADAPTER, STRAIGHT, TUBE TO HOSE	1
58	XDOZZ		92878	40202-01	• WIRE, ELECTRICAL	1
59	PAOZZ	5940-01-530-4760	58961	31535	• • TERMINAL, QUICK DISCONNECT	1
60	PAOZZ	5940-00-114-1300	96906	MS20659-105	• • TERMINAL, LUG.....	1
61	XDOOO		92878	40404	• RELAY ASSEMBLY	1
62	PAOZZ	5945-01-170-6666	53867	0 332 209 203	• • RELAY, ELECTROMAGNETIC.....	3
63	XDOOO		92878	40444	• • WIRING HARNESS	1
64	PAOZZ	5940-01-513-1400	39428	7113K24	• • • TERMINAL, LUG	1
65	PAOZZ	5940-01-486-5422	00779	640907-1	• • • TERMINAL, QUICK DISCONNECT.....	1

(1) ITEM NO	(2) SMR CODE	(3) NATIONAL STOCK NUMBER	(4) CAGEC	(5) PART NUMBER	(6) DESCRIPTION AND USABLE ON CODE (UOC)	(7) QTY
66	XDOZZ		00779	696363-1	• • • TERMINAL, PIGGY BACK, 18-22 GA	1
67	PAOZZ	5940-00-378-7225	06383	DV14-250M	• • • TERMINAL, QUICK DISCONNECT	1
END OF FIGURE						

OPERATOR, FIELD AND SUSTAINMENT MAINTENANCE

LARGE CAPACITY FIELD HEATER (LCFH)

BURNER FUEL VALVE ASSEMBLY
40208

REPAIR PARTS LIST

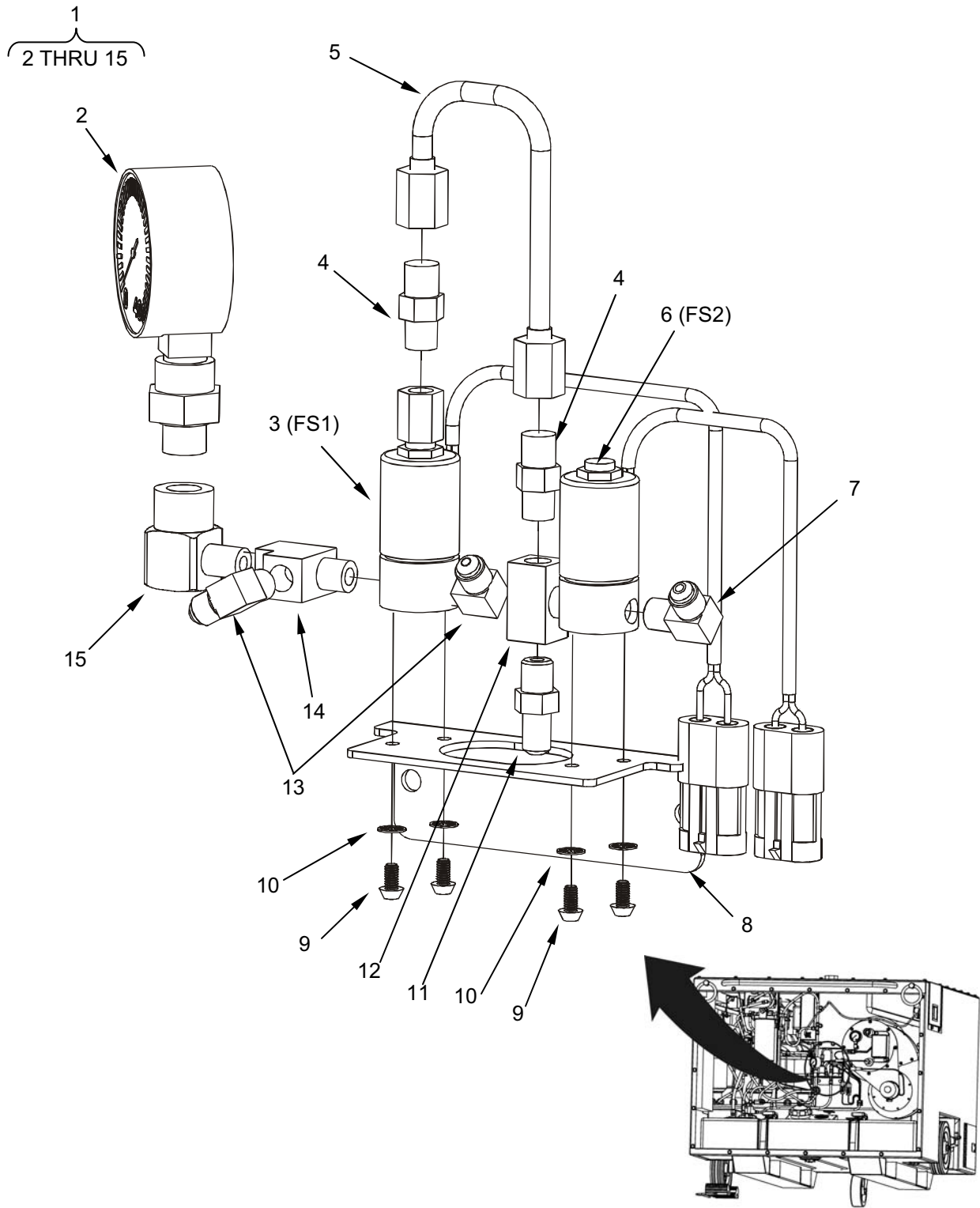

Figure 5. Burner Fuel Valve Assembly

(1)	(2)	(3)	(4)	(5)	(6)	(7)
ITEM NO	SMR CODE	NATIONAL STOCK NUMBER	CAGEC	PART NUMBER	DESCRIPTION AND USABLE ON CODE (UOC)	QTY
					GROUP 02	
					FIG. 5 BURNER FUEL VALVE ASSEMBLY	
1	XDOOO		92878	40208	BURNER FUEL VALVE ASSEMBLY.....	1
2	PAOZZ	6685-01-539-8272	92878	40252	• GAGE, PRESSURE, DIAL INDICATING.....	1
3	PAOZZ	4810-01-539-7206	92878	40281	• VALVE, SOLENOID	1
4	PAOZZ	4730-00-003-5919	96906	MS51819-3	• ADAPTER, STRAIGHT, PIPE TO TUBE.....	2
5	XDOZZ		92878	40288	• PIPE ASSEMBLY, METALLIC	1
6	PAOZZ	4810-01-540-2889	92878	40282	• VALVE, SOLENOID	1
7	PAOZZ	4730-00-254-6211	92878	3655	• ELBOW, PIPE TO TUBE.....	1
8	XDOZZ		92878	40280	• BRACKET, MOUNTING	1
9	PAOZZ	5305-00-889-3002	80205	MS35206-242	• SCREW, MACHINE.....	4
10	PAOZZ	5310-00-559-0070	80205	MS35333-38	• WASHER, LOCK.....	4
11	PAOZZ	4730-00-900-3296	01276	2000-2-4B	• ADAPTER, STRAIGHT, PIPE TO TUBE.....	1
12	PAOZZ	4730-00-595-0251	15434	C0502005700	• TEE, PIPE	1
13	PAOZZ	4730-00-541-8100	92878	22319	• ELBOW, PIPE TO TUBE.....	2
14	PAOZZ	4730-00-263-2733	93061	VS2225P-2	• TEE, PIPE	1
15	PAOZZ	4730-00-289-2368	01276	3400X4X2	• ELBOW, PIPE	1
					END OF FIGURE	

OPERATOR, FIELD AND SUSTAINMENT MAINTENANCE

LARGE CAPACITY FIELD HEATER (LCFH)

FUEL TANK

40508

REPAIR PARTS LIST

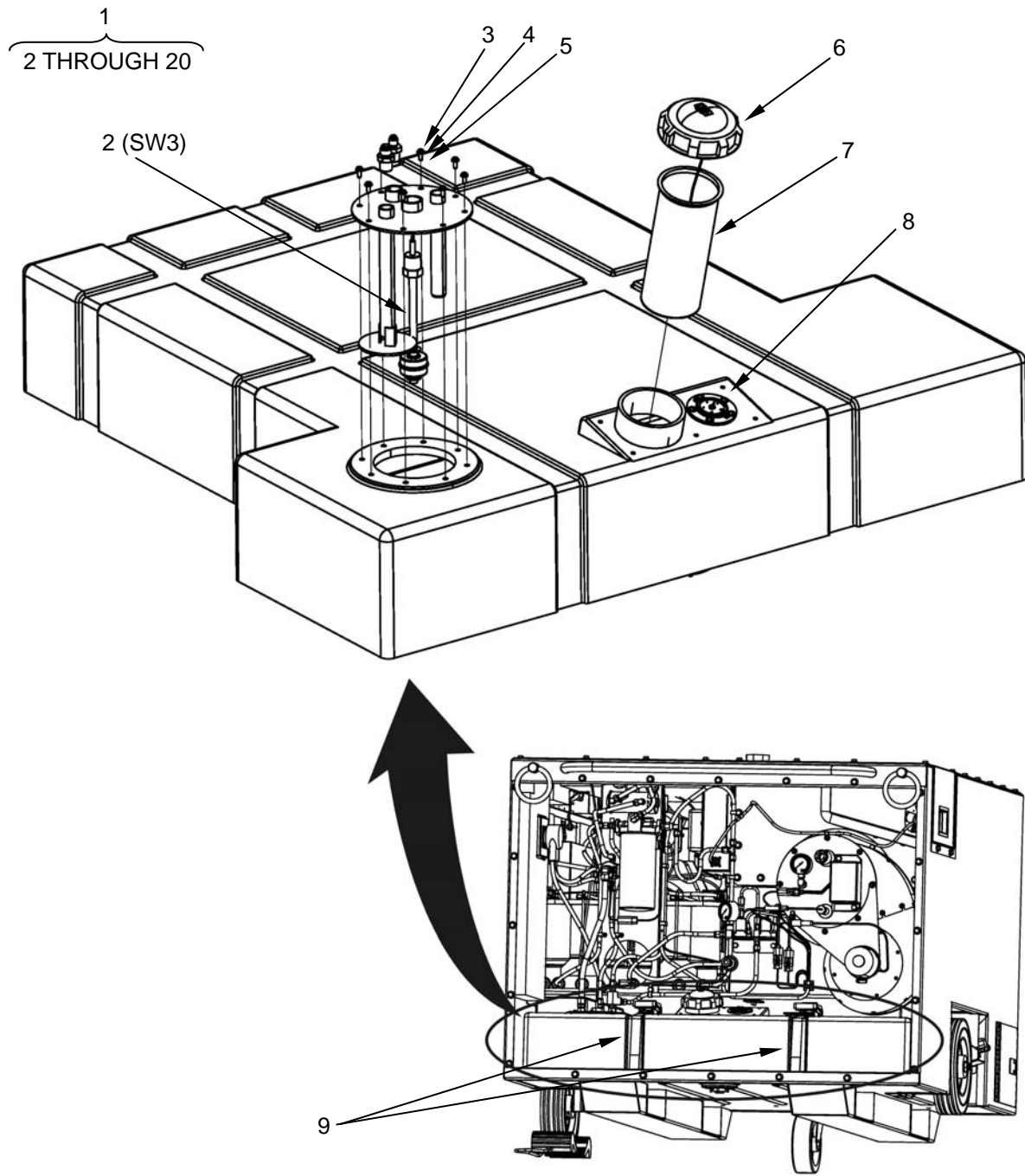

Figure 6. Fuel Tank (Sheet 1 of 3).

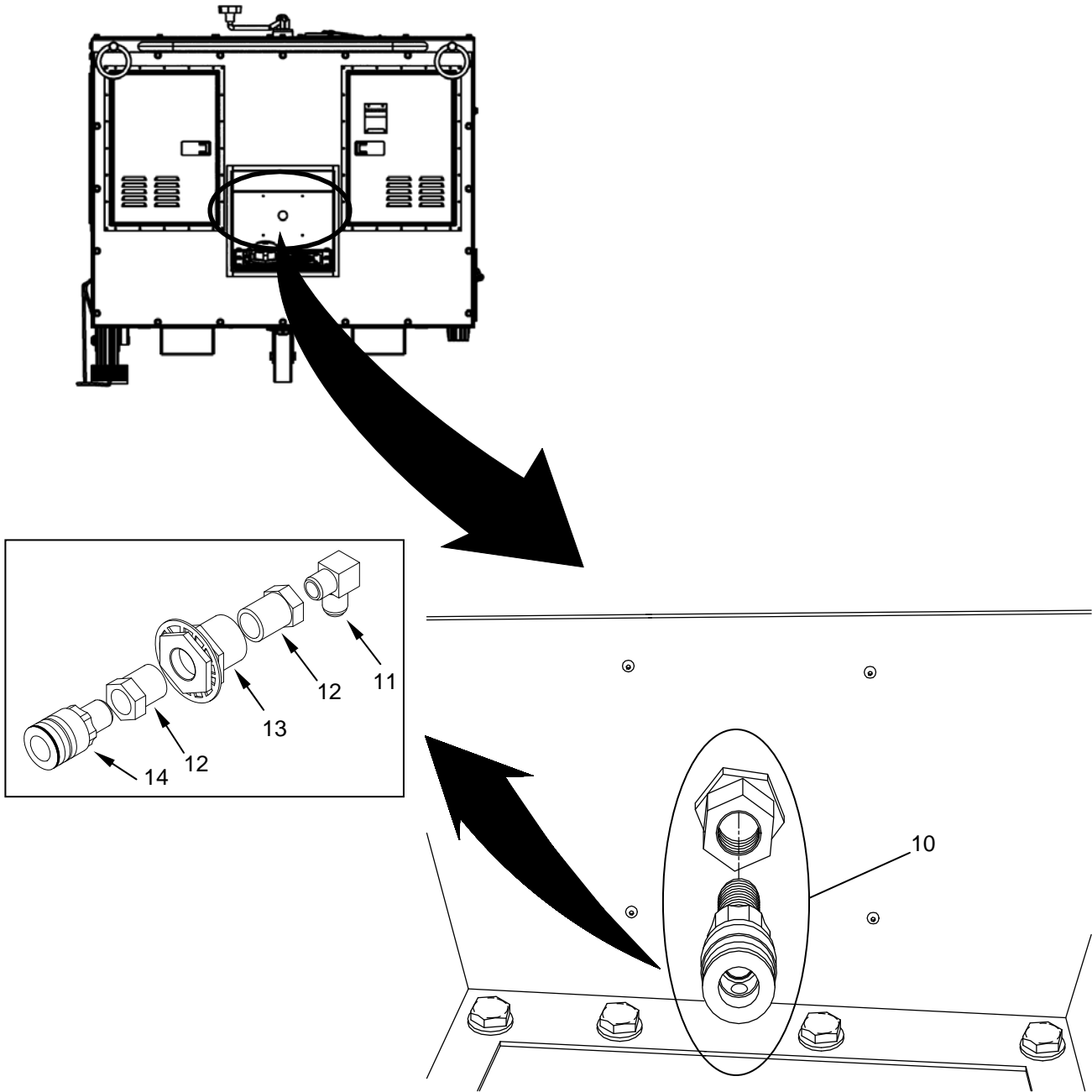

Figure 6. Connector, External, Fuel Supply (Sheet 2 of 3).

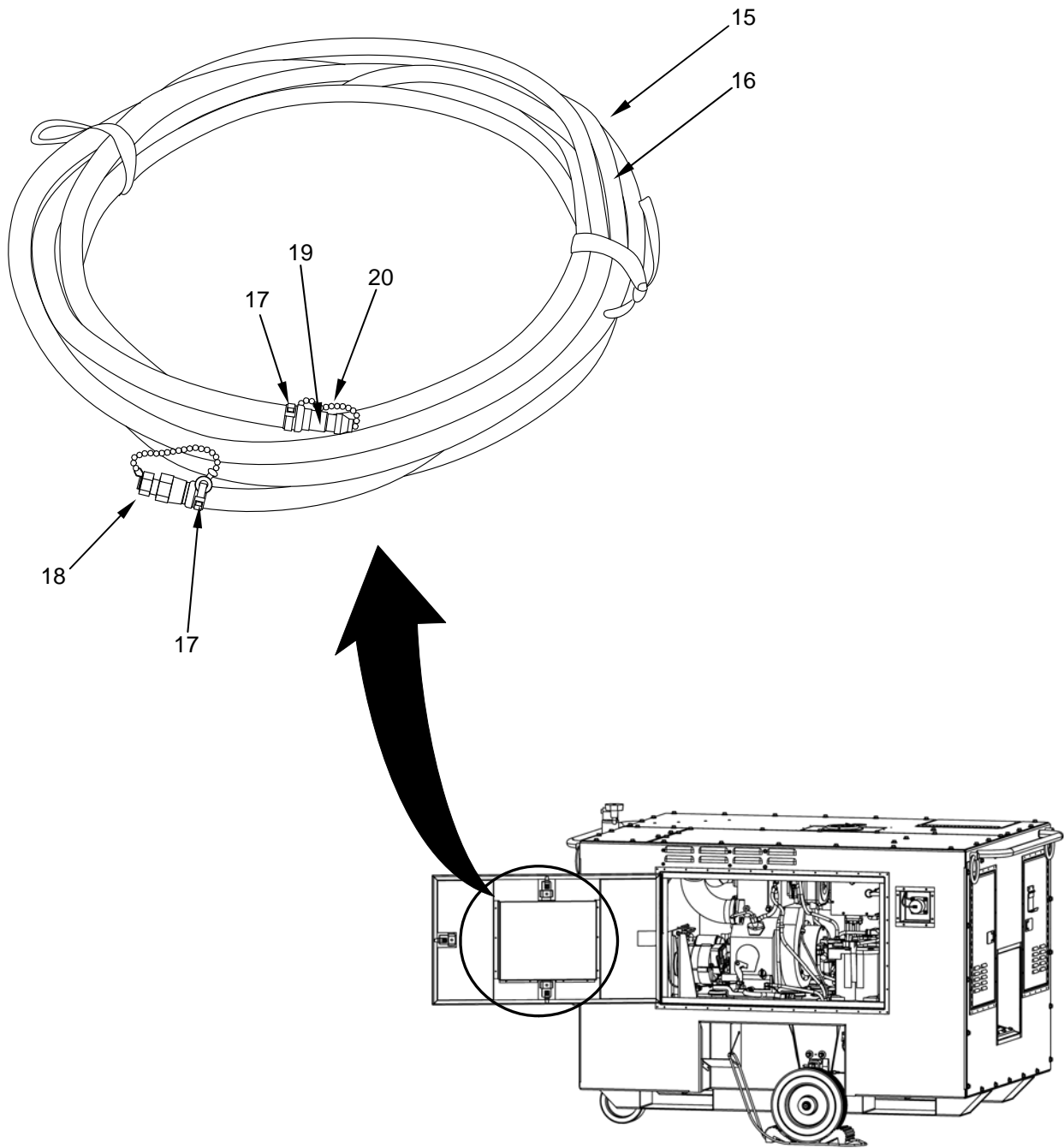

Figure 6. Assembly, Fuel Hose, External (Sheet 3 of 3).

(1)	(2)	(3)	(4)	(5)	(6)	(7)
ITEM NO	SMR CODE	NATIONAL STOCK NUMBER	CAGEC	PART NUMBER	DESCRIPTION AND USABLE ON CODE (UOC)	QTY
					GROUP 02	
					FIG. 6 FUEL TANK	
1	XDOOO		92878	40508	TANK, FUEL.....	1
2	PAOZZ	6680-01-539-7185	92878	40240	. SWITCH, LIQUID LEVEL	1
3	PAOZZ	5305-00-470-3321	96906	MS51849-74	. SCREW, MACHINE.....	8
4	PAOZZ	5310-00-014-5850	96906	MS27183-42	. WASHER, FLAT	8
5	PAOZZ	5310-00-045-3296	96906	MS35338-43	. WASHER, LOCK	8
6	PAOZZ	5342-01-539-7195	23224	202498	. CAP, FILLER OPENING.....	1
7	PAOZZ	4730-01-540-3594	92878	75116-100	. STRAINER, SEDIMENT	1
8	PAOZZ	6680-01-550-1327	09393	6874-00009	. GAUGE, LIQUID QUANTITY, FLOAT TYPE	1
9	XDOZZ		92878	75237-100	STRAPS, RESTRAINING.....	2
10	PAOZZ	4520-01-539-7200	92878	40207	ASSEMBLY, EXTERNAL FUEL SUPPLY PORT	1
11	PAOZZ	4730-00-254-6225	81343	4-4010202B	. ELBOW, PIPE TO TUBE	1
12	PAOZZ	4730-00-202-6491	01276	3220X6X4	. BUSHING, PIPE	2
13	XDOZZ		39428	50785K274	. REDUCER, PIPE.....	1
14	PAOZZ	4730-00-894-5574	39425	6536K18	. COUPLING HALF, QUICK DISCONNECT.....	2
15	PAOOO	4720-01-540-3595	92878	40702	HOSE ASSEMBLY, NONMETALLIC.....	1
16	MOOZZ	4720-00-913-5910	01276	2565-4	. HOSE, NONMETALLIC (MAKE FROM BULK SUPPLY).....	1
17	XDOZZ		92878	106534	. STRAP, TIEDOWN. ELECTRICAL COMPONENTS.....	2
18	PAOZZ	4730-01-539-7172	92878	40724	. CAP, HOSE	1
19	PAOZZ	4730-00-073-2151	01276	4797-5-4B	. ADAPTER, STRAIGHT, TUBE TO HOSE	1
20	PAOZZ	4520-01-493-2785	92878	5-13-5616	. FUEL CAP ASSEMBLY, SHC	1
					END OF FIGURE	

OPERATOR, FIELD AND SUSTAINMENT MAINTENANCE

LARGE CAPACITY FIELD HEATER (LCFH)

INLET FAN

40185

REPAIR PARTS LIST

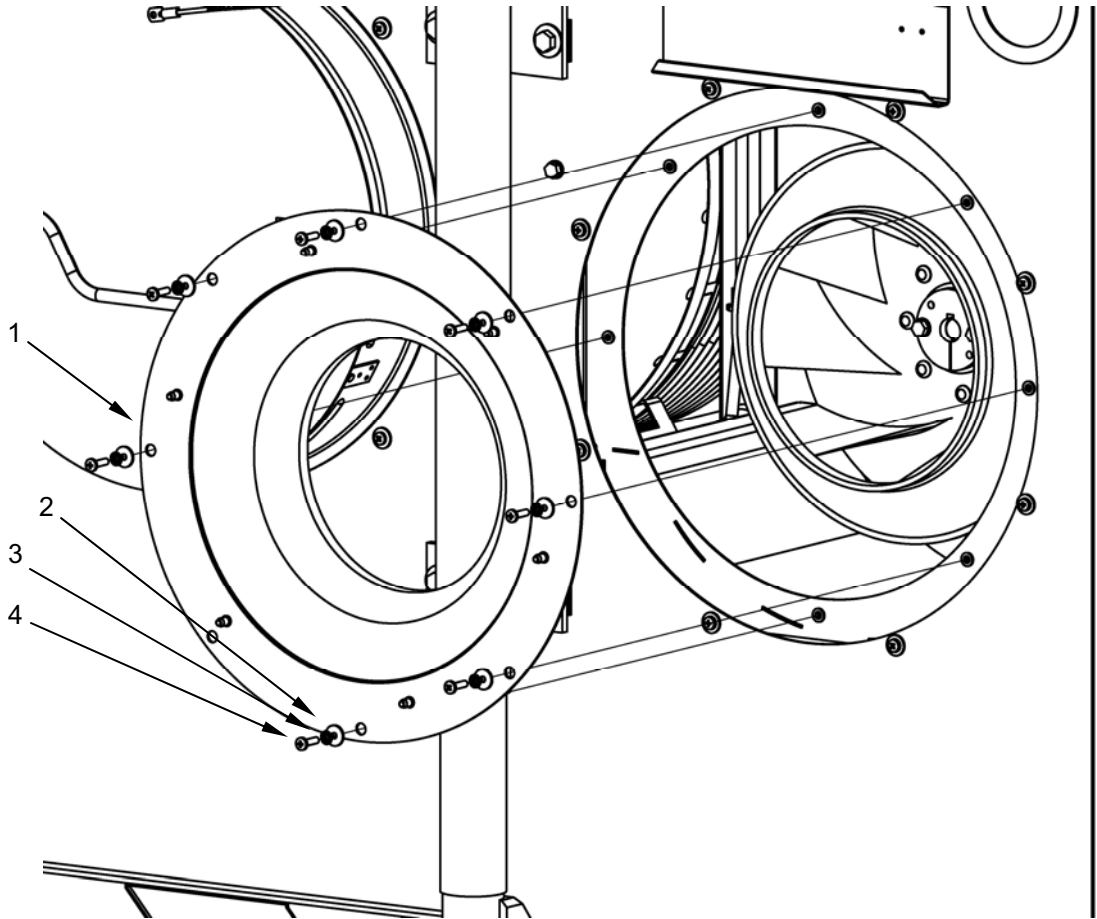

Figure 7. Inlet Fan Assembly (Sheet 1 of 3)

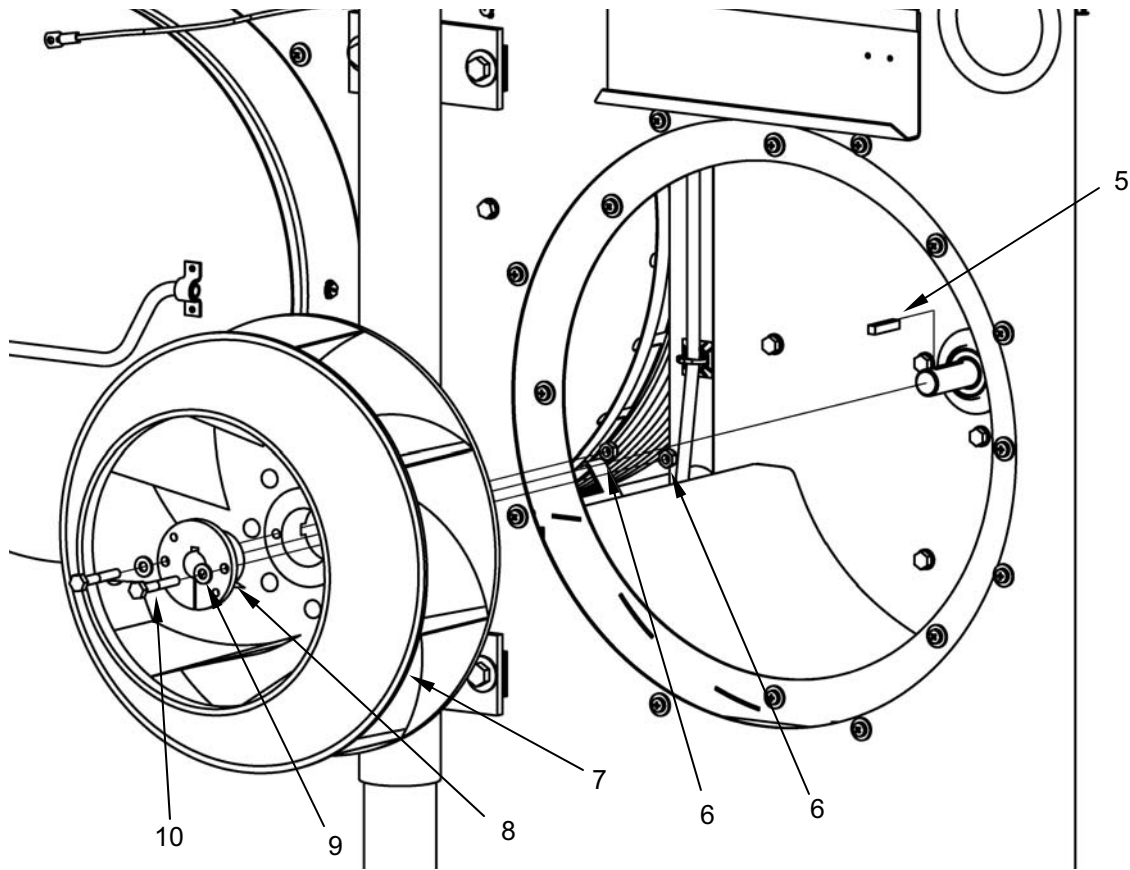

Figure 7. Inlet Fan Assembly (Sheet 2 of 3)
0100 00-3

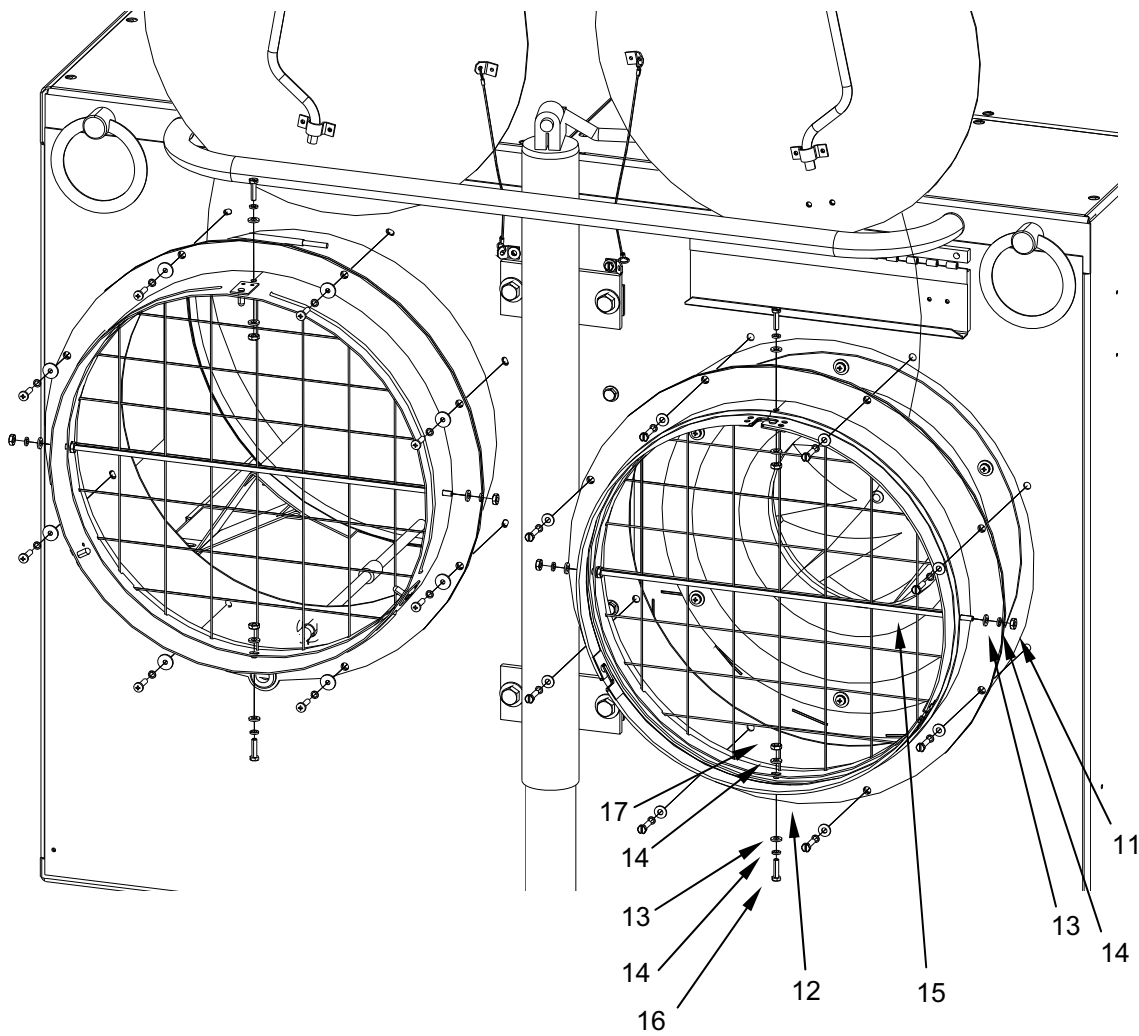

Figure 7. Inlet Fan Assembly (Sheet 3 of 3)

(1)	(2)	(3)	(4)	(5)	(6)	(7)
ITEM NO	SMR CODE	NATIONAL STOCK NUMBER	CAGEC	PART NUMBER	DESCRIPTION AND USABLE ON CODE (UOC)	QTY
					GROUP 03	
					FIG. 7 INLET FAN	
1	XDOZZ		92878	40185	INLET FAN	1
2	PAOZZ	5310-00-637-9221	25612	GW10U606SC2	WASHER, FLAT	7
3	PAOZZ	5310-00-596-7691	80020	NAF1058-10E	WASHER, LOCK	17
4	PAOZZ	5305-00-989-7435	80205	MS35207-264	SCREW, MACHINE.....	11
5	XDOZZ		92878	40162	KEY, MACHINE.....	1
6	PAOZZ	5310-00-061-7325	96906	MS21045-4	NUT, SELF-LOCKING, HEXAGON	2
7	XDOZZ		92878	40184	IMPELLER, FAN, CENTRIFUGAL	1
8	XDOZZ		92878	40186	HUB, FAN, CLUTCH	1
9	PAOZZ	5310-00-809-4058	96906	MS27183-10	WASHER, FLAT	24
10	PAOZZ	5306-01-303-2815	80205	MS90725-13	BOLT, MACHINE.....	2
11	PAOZZ	5310-00-934-9758	80205	MS35649-202	NUT, PLAIN, HEXAGON	9
12	XDOZZ		92878	40516	AIR INLET CONNECTION	1
13	PAOZZ	5310-00-014-5850	96906	MS27183-42	WASHER, FLAT	8
14	PAOZZ	5310-00-045-3296	96906	MS35338-43	WASHER, LOCK	4
15	XDOZZ		92878	75259-1	ROD, THREADED END	1
16	PAOZZ	5305-00-179-8946	96906	MS51849-66	SCREW, MACHINE.....	2
17	PAOZZ	5310-00-934-9751	80205	MS53650-302	NUT, PLAIN, HEXAGON 10-32.....	6
					END OF FIGURE	

OPERATOR, FIELD AND SUSTAINMENT MAINTENANCE

LARGE CAPACITY FIELD HEATER (LCFH)

ASSEMBLY, ENGINE SYSTEM

40100

REPAIR PARTS LIST

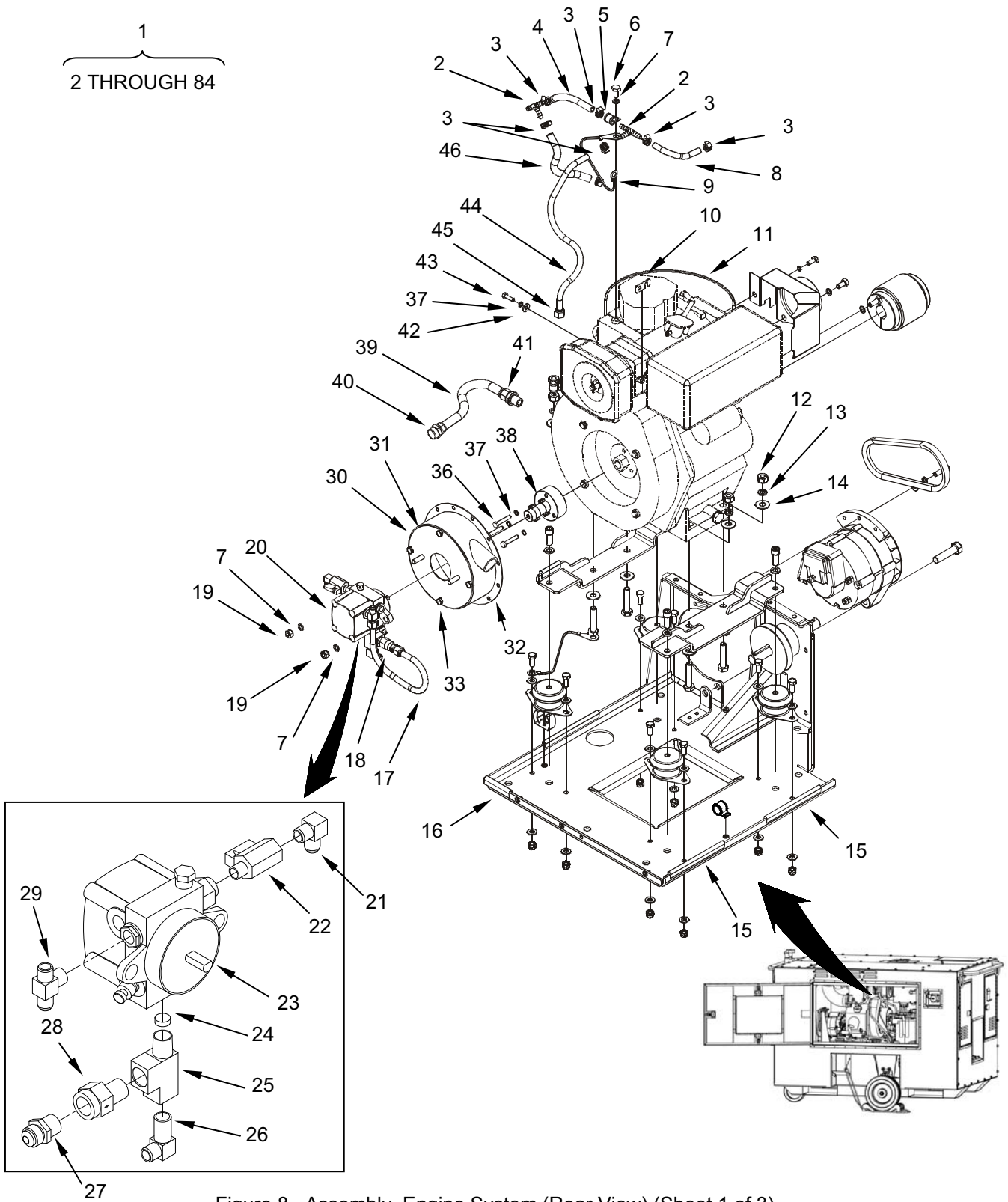

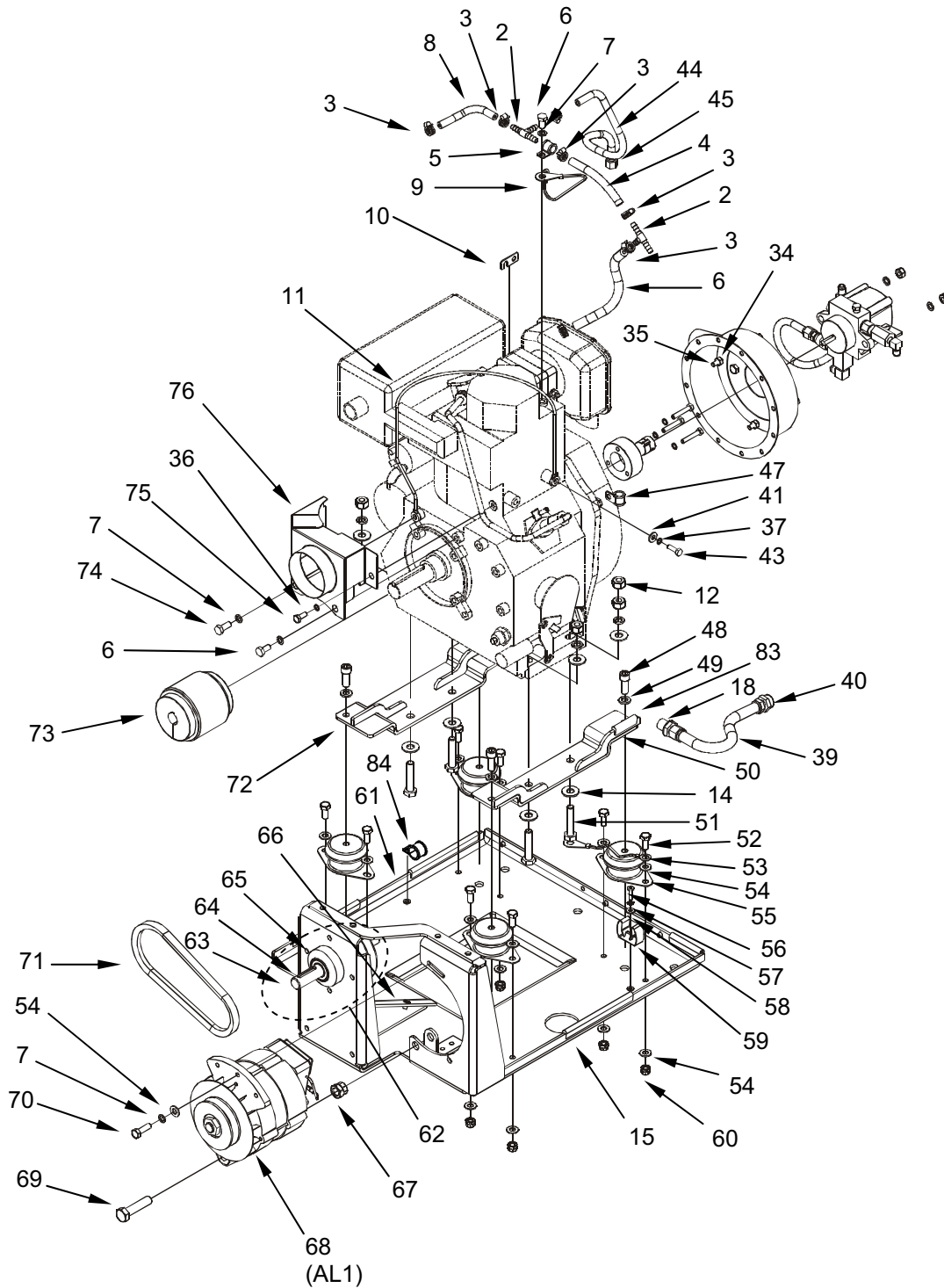

Figure 8. Assembly, Engine System (Front View) (Sheet 2 of 3).

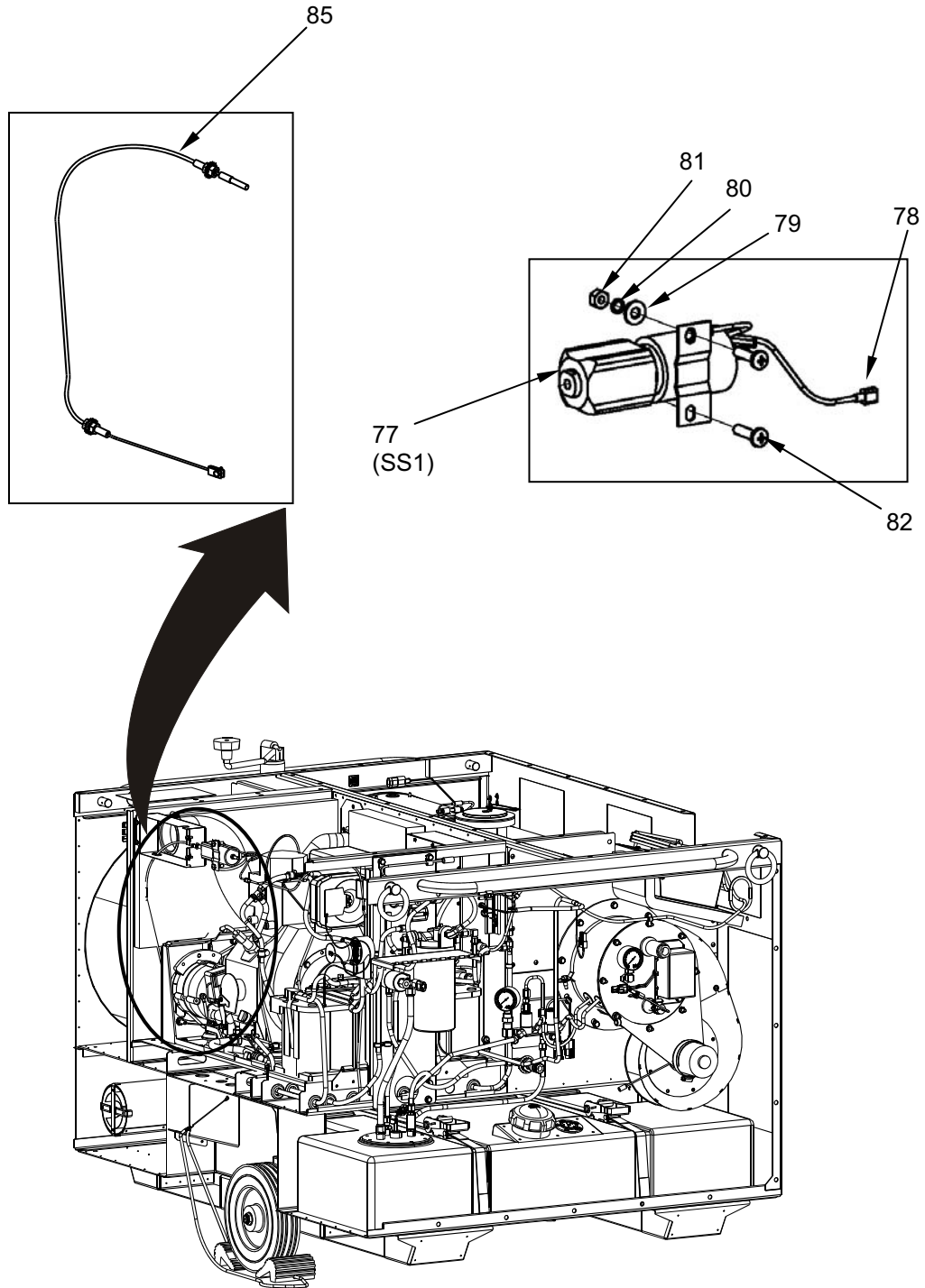

Figure 8. Assembly, Engine System (Engine Stop Solenoid and Cable Detail) (Sheet 3 of 3).

(1) ITEM NO	(2) SMR CODE	(3) NATIONAL STOCK NUMBER	(4) CAGEC	(5) PART NUMBER	(6) DESCRIPTION AND USABLE ON CODE (UOC)	(7) QTY
GROUP 03						
FIG. 8 ASSEMBLY, ENGINE SYSTEM						
1	XDOOO		92878	40100	ASSEMBLY, ENGINE SYSTEM.....	1
2	PAOZZ	4730-01-058-9758	93061	224-4	• TEE, HOSE	2
3	PAOZZ	4730-01-424-5432	39428	5321K14	• CLAMP, HOSE	7
4	MOOZZ		92878	40191	• HOSE, NONMETALLIC (MAKE FROM BULK NSN 4720-00-913-5910)	1
5	PAOZZ	5340-00-057-3043	96906	MS21333-112	• CLAMP, LOOP	2
6	PAOZZ	5310-01-465-7108	39428	91280A524	• SCREW, CAP, HEXAGON HEAD	2
7	PAOZZ	5310-00-407-9566	80205	MS35338-45	• WASHER, LOCK.....	6
8	MOOZZ		92878	40190	• HOSE, NONMETALLIC (MAKE FROM BULK NSN 4720-00-913-5910)	1
9	XDOZZ		92878	52161	• STRIP, ELECTRICAL GROUNDING.....	1
10	XDOZZ		92878	40195	• BUS, CONDUCTOR.....	1
11	XDOZZ		92878	40119	• STRAP, ENGINE LIFT	1
12	PAOZZ	5310-01-137-4830	72741	430-010	• NUT, PLAIN, HEXAGON.....	5
13	PAOZZ	5310-00-637-9541	81718	H2525M	• WASHER, LOCK.....	4
14	PAOZZ	5310-00-809-4061	96906	MS27183-15	• WASHER, FLAT	8
15	MOOZZ		92878	40196	• MOLDING, PLASTIC (MAKE FROM BULK P/N 8451A53, CAGEC 0E328).....	3
16	MOOZZ		92878	40199	• MOLDING, PLASTIC (MAKE FROM BULK P/N 8451A53, CAGEC 0E328).....	1
17	XDOOO		92878	40198	• HOSE, NONMETALLIC.....	1
18	PAOZZ	4730-00-555-1152	70281	2203B510	• • ADAPTER, STRAIGHT, TUBE TO HOSE	1
19	PAOZZ	5310-00-880-7744	96906	MS51967-5	• NUT, PLAIN, HEXAGON.....	2
20	XDOZZ		92878	40201	• ASSEMBLY, FUEL PUMP.....	1
21	PAOZZ	4730-00-254-6211	81343	J5124- 2010202B	• • ELBOW, PIPE TO TUBE.....	1
22	PAOZZ	4820-01-475-9972	93061	MV602-2	• • VALVE, BALL	1
23	PAOZZ	2910-01-539-7203	92878	40200	• • PUMP, FUEL, METERING AND DISTRIBUTING	1
24	XDOZZ		07BY4	4534K39	• • • PLUG, TUBE FITTING, THREADED.....	1
25	PAOZZ	4730-00-277-9615	92878	A17004-2	• • TEE, PIPE	1
26	PAOZZ	4730-00-254-6225	81343	4-4010202B	• • ELBOW, PIPE TO TUBE.....	1
27	PAOZZ	4730-00-723-5549	29215	JD659	• • ADAPTER, STRAIGHT, PIPE TO TUBE	1
28	XDOZZ		92878	40211	• • VALVE, CHECK	1
29	PAOZZ	4730-01-157-5156	92878	45X4X4X4	• • TEE, PIPE TO TUBE.....	1
30	XDOZZ		92878	40115	• ASSEMBLY, PUMP MOUNT.....	1
31	XAOZZ		92878	40112	• • PLATE, MOUNTING, FUEL PUMP	1

(1)	(2)	(3)	(4)	(5)	(6)	(7)
ITEM NO	SMR CODE	NATIONAL STOCK NUMBER	CAGEC	PART NUMBER	DESCRIPTION AND USABLE ON CODE (UOC)	QTY
32	XAOZZ		92878	40111	● ● HOUSING, PULL START, MODIFIED.....	1
33	PAOZZ	5305-00-068-0502	96906	MS90725-6	● ● SCREW, CAP, HEXAGON HEAD.....	4
34	PAOZZ	5310-00-543-2410	80205	MS35338-40	● ● WASHER, LOCK.....	4
35	PAOZZ	5310-00-761-6882	96906	MS51967-2	● ● NUT, PLAIN, HEX.....	4
36	XDOZZ		39428	91280A340	● SCREW, CAP, HEX HEAD.....	3
37	PAOZZ	5310-00-582-5965	99539	CBM21389	● WASHER, LOCK.....	4
38	PAOZZ	4520-01-539-7204	92878	40213	● COUPLING, DRIVE SHAFT.....	1
39	XDOZZ		92878	40107	● HOSE ASSEMBLY.....	1
40	PAOZZ	4730-01-231-2751	01276	10006B-106	● ● ADAPTER, STRAIGHT, PIPE TO HOSE.....	1
41	PAOZZ	4730-00-588-2614	30780	30682-6-6B	● ● ADAPTER, STRAIGHT, TUBE TO HOSE.....	1
42	PAOZZ	5310-00-809-4058	96906	MS27183-10	● WASHER, FLAT.....	1
43	XDOZZ		39428	91280A330	● SCREW, CAP, HEX HEAD.....	1
44	XDOZZ		96906	40197	● HOSE ASSEMBLY, NONMETALLIC.....	1
45	PAOZZ	4730-00-555-1152	70281	2203B510	● ● ADAPTER, STRAIGHT, TUBE TO HOSE.....	1
46	MOOZZ		92878	40192	● HOSE, NONMETALLIC (MAKE FROM BULK NSN 4720-01-499-3769).....	1
47	PAOZZ	5340-00-598-0597	81343	AS21919DG8	● CLAMP, LOOP.....	2
48	PAOZZ	5305-01-454-7982	59167	NAS1352-6-16P	● SCREW, CAP, SOCKET HEAD.....	4
49	PAOZZ	5310-00-637-9541	80205	MS35338-46	● WASHER, LOCK.....	4
50	XDOZZ		92878	40146	● BRACKET, MOUNTING.....	1
51	XDOZZ		39428	91280A643	● BOLT, MACHINE.....	4
52	PAOZZ	5306-00-050-1238	80204	B1821BH031F0 75N	● BOLT, MACHINE.....	8
53	XDOZZ		92878	52161	● STRIP, ELECTRICAL GROUNDING.....	1
54	PAOZZ	5310-00-081-4219	96906	MS27183-12	● WASHER, FLAT.....	17
55	PAOZZ		92878	40104	● MOUNT, ENGINE.....	4
56	PAOZZ	5305-00-989-7435	80205	MS35207-264	● SCREW, MACHINE.....	1
57	PAOZZ	5310-00-596-7691	96906	MS35335-32	● WASHER, LOCK.....	1
58	PAOZZ	5310-00-014-5850	96906	MS27183-42	● WASHER, FLAT.....	1
59	PAOZZ	5340-01-153-0578	39428	1723A22	● CLIP, SPRING TENSION.....	1
60	PAOZZ	5310-00-880-7744	96906	MS21045-5	● NUT, PLAIN, HEXAGON.....	8
61	XDOZZ		92878	40102	● PLATE, MOUNTING, ENGINE.....	1
62	XAOZZ		92878	40165	● ● BEARING AND SHAFT ASSEMBLY...	1
63	XAOZZ		92878	40106	● ● ● SHAFT, SHOULDERED.....	1
64	XAOZZ		92878	40163	● ● ● KEY, MACHINE.....	1
65	XAOZZ		92878	40161	● ● ● PULLEY, GROOVE.....	1

(1) ITEM NO	(2) SMR CODE	(3) NATIONAL STOCK NUMBER	(4) CAGEC	(5) PART NUMBER	(6) DESCRIPTION AND USABLE ON CODE (UOC)	(7) QTY
66	PAOZZ	5305-00-068-0501	06315	AC65-4-5	• SCREW, CAP, HEXAGON HEAD	7
67	PAOZZ	5310-00-062-4954	80205	MS21045-8	• NUT, SELF-LOCKING, HEXAGON	1
68	PAOZZ	4520-01-539-7194	92878	40103	• ALTERNATOR, 24V	1
69	PAOZZ	5305-00-226-7768	96906	MS90726-115	• SCREW, CAP, HEXAGON HEAD, 1/2 X 2.00 IN GRD 5.....	1
70	PAOZZ	5306-00-225-8499	80205	MS90725-34	• BOLT, MACHINE.....	1
71	PAOZZ	3030-01-539-7196	92878	40132	• BELT, V	1
72	XDOZZ		92878	40147	• BRACKET, ENGINE MOUNT.....	1
73	PAOZZ	3010-01-539-7198	92878	40105	• COUPLING,SHAFT,FLEXIBLE	1
74	PAOZZ	5305-12-156-4863	39428	91280A530	• SCREW, CAP, HEX HEAD	1
75	PAOZZ	5305-00-068-0501	80205	MS90725-5	• SCREW, CAP, HEXAGON HEAD	1
76	XDOZZ		92878	40563	• BAFFLE, AIRFLOW, ENGINE.....	1
77	PAOZZ	5945-01-539-8273	92878	40139	• SOLENOID, ELECTRICAL.....	1
78	PAOZZ	5940-01-139-0853	56501	RB25177	• • TERMINAL, LUG.....	1
79	PAOZZ	5310-00-809-4058	96906	MS27183-10	• WASHER, FLAT	2
80	PAOZZ	5310-00-543-2410	80205	MS35338-40	• WASHER, LOCK.....	2
81	PAOZZ	5310-00-761-6882	96906	MS51967-2	• NUT, PLAIN, HEX	2
82	PAOZZ	5305-00-988-1727	80205	MS35206-283	• SCREW, MACHINE.....	2
83	MOOZZ		92878	40196	• MOLDING, PLASTIC (MAKE FROM BULK P/N 8451A53, CAGEC 0E328).....	1
84	PAOZZ	5340-01-466-7801	96906	MS21919-6	• CLAMP, LOOP	1
85	PAOZZ	4520-01-539-8275	92878	40138	• CABLE, ENGINE STOP	1
END OF FIGURE						

OPERATOR, FIELD AND SUSTAINMENT MAINTENANCE

LARGE CAPACITY FIELD HEATER (LCFH)

ENGINE, DIESEL

40101

REPAIR PARTS LIST

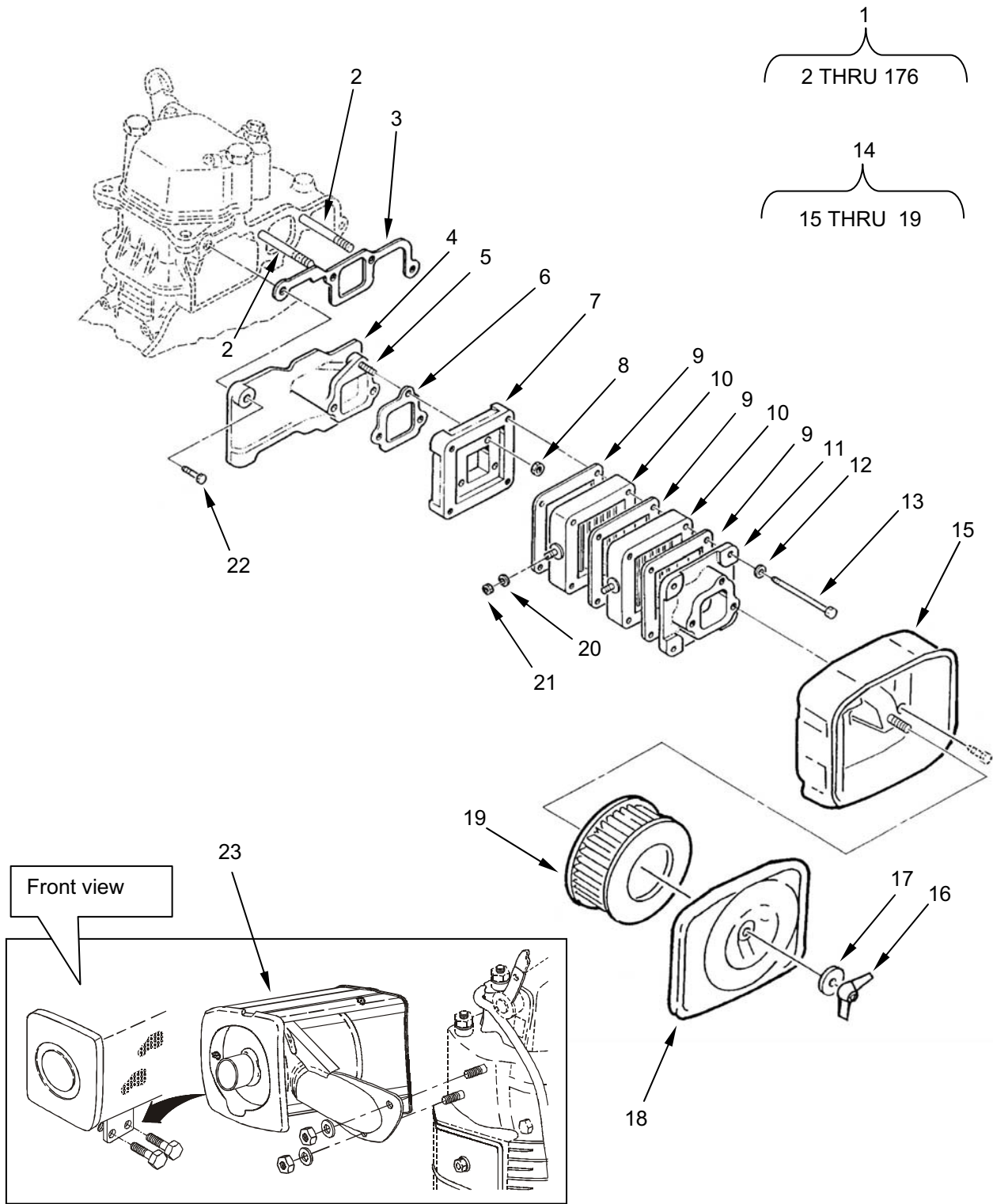

Figure 9. Engine, Diesel (Sheet 1 of 9)
(Air Cleaner and Muffler Assemblies).

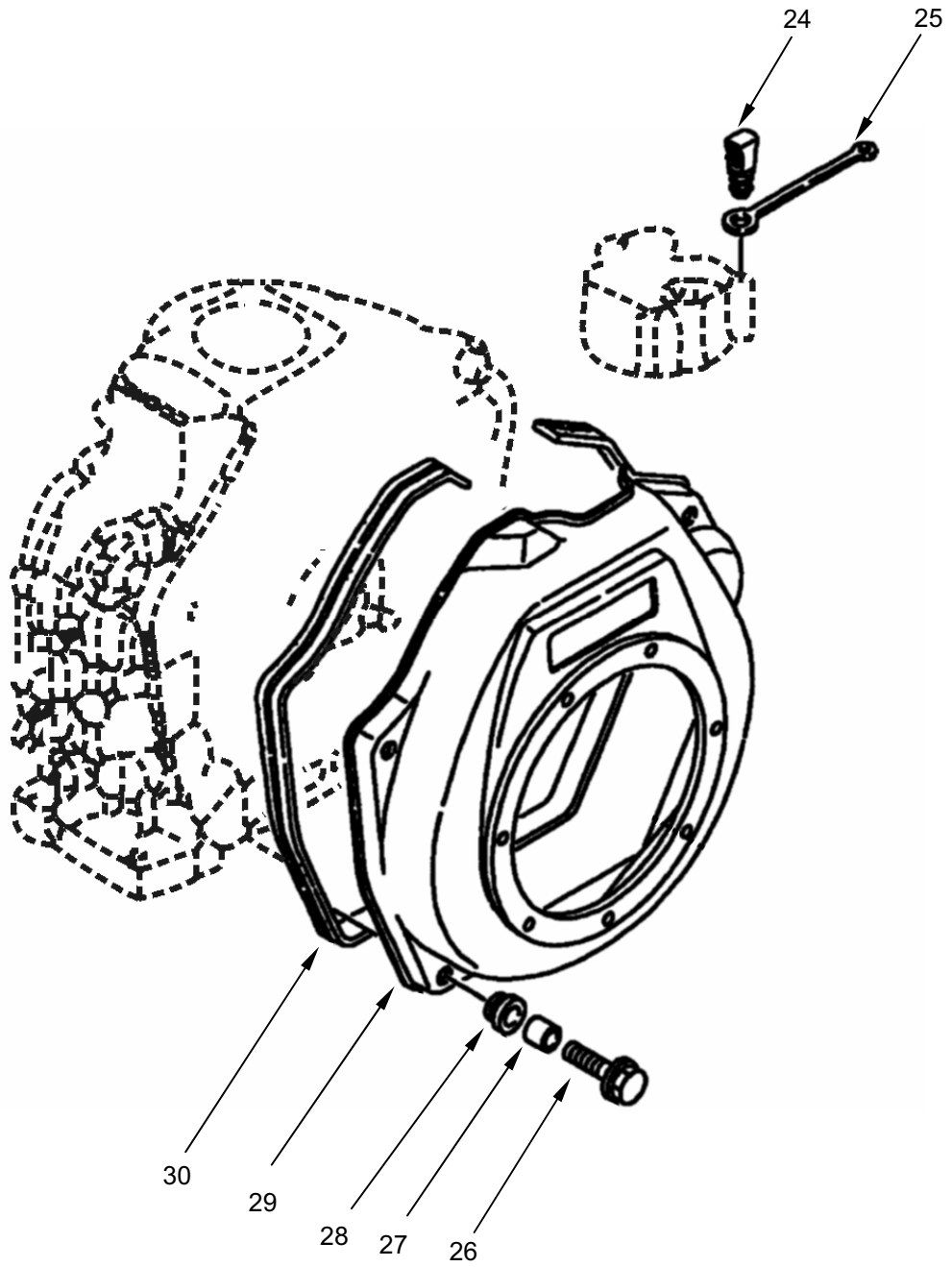

Figure 9. Engine, Diesel (Sheet 2 of 9)
(Cooling and Starting Device).

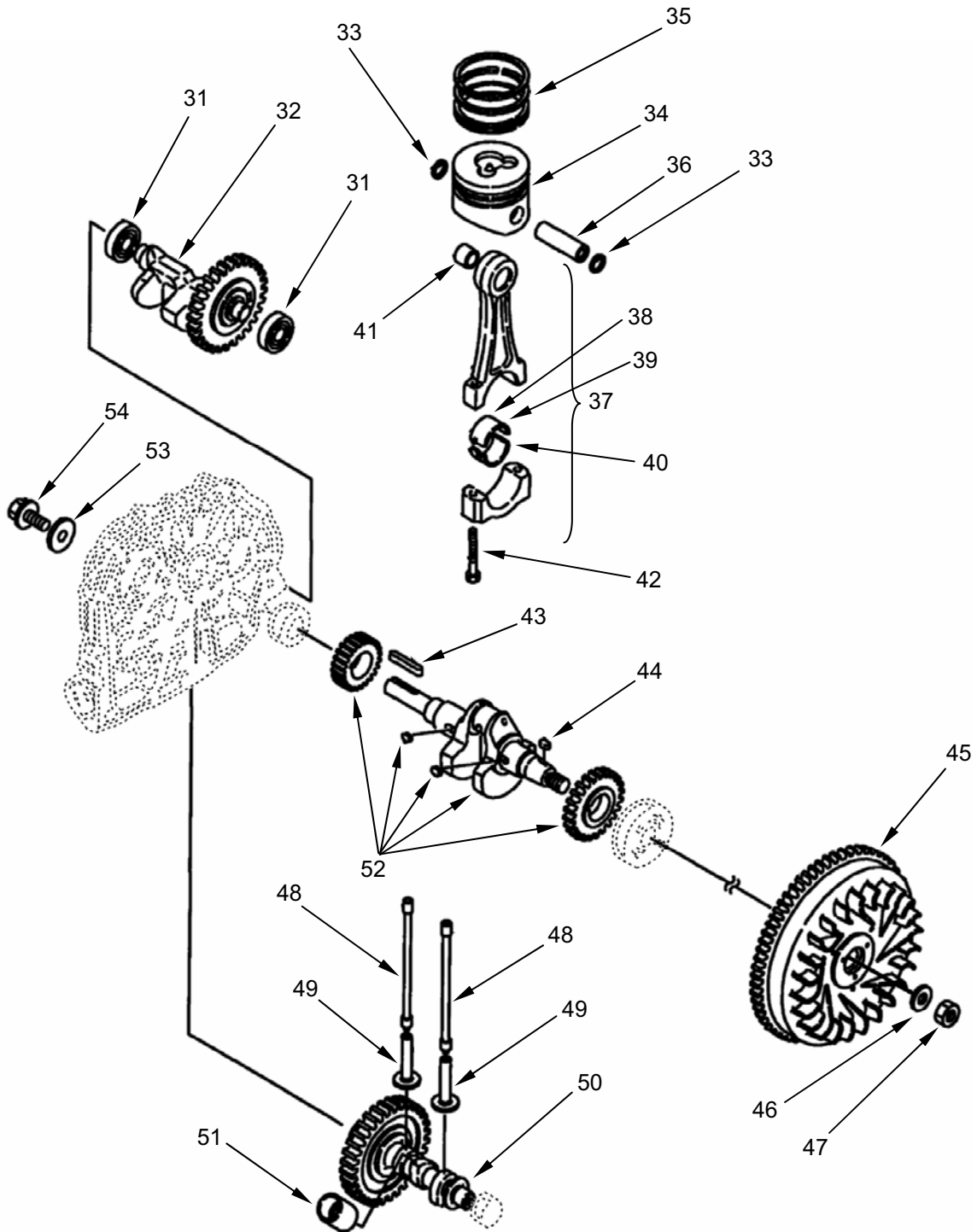

Figure 9. Engine, Diesel (Sheet 3 of 9)
(Crankshaft, Piston, and Camshaft).

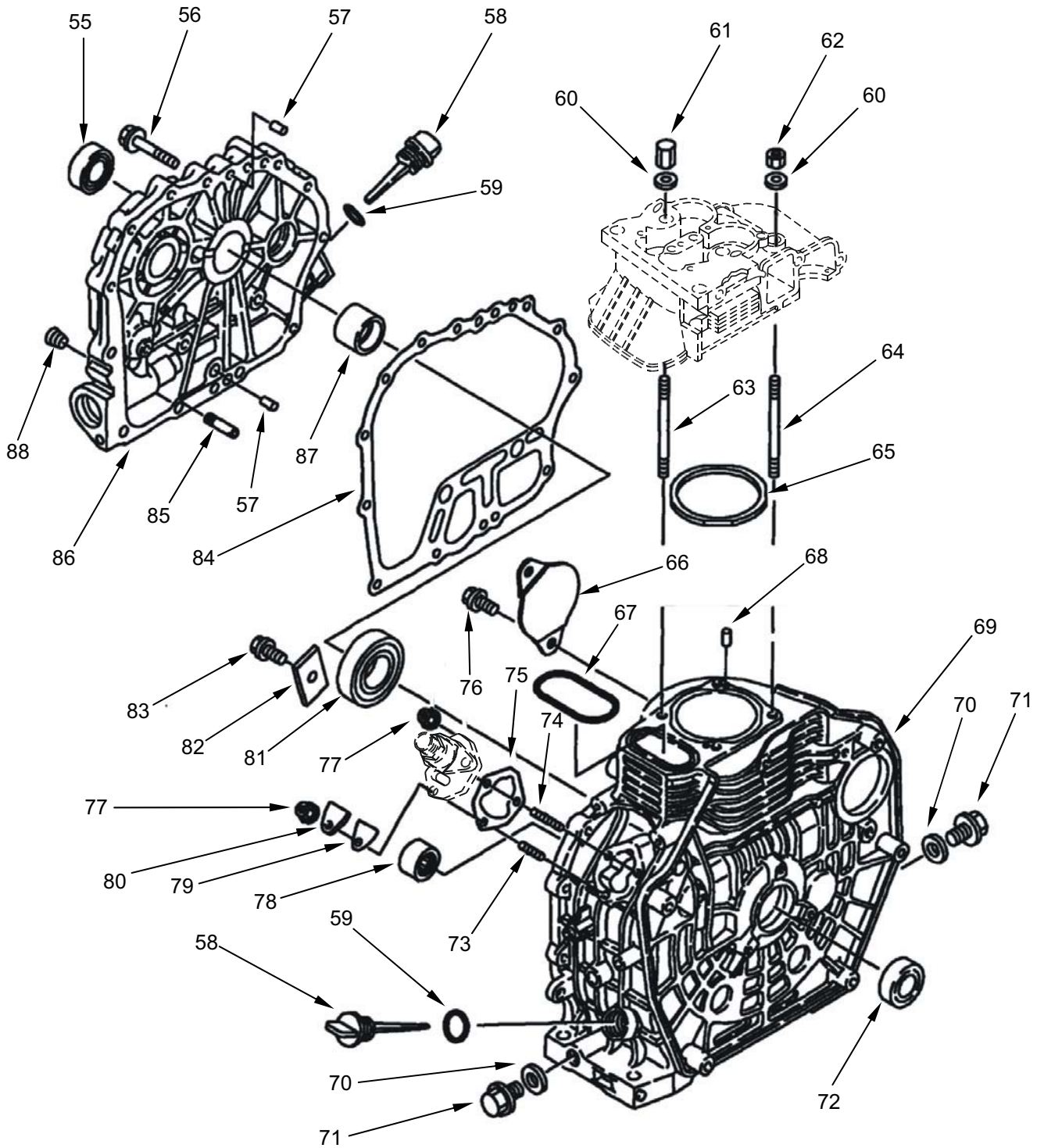

Figure 9. Engine, Diesel (Sheet 4 of 9)
(Cylinder Block).

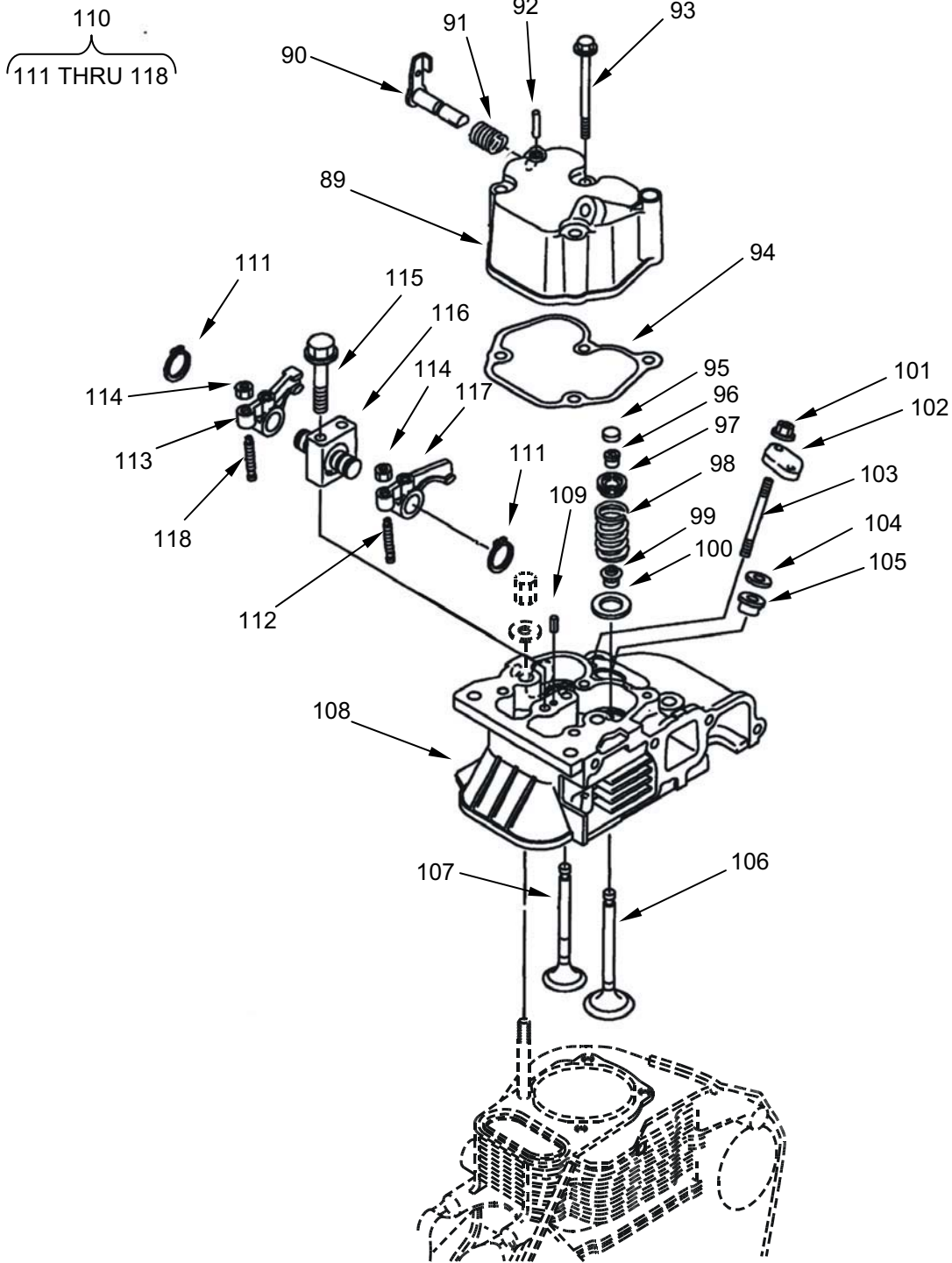

Figure 9. Engine, Diesel (Sheet 5 of 9)
(Cylinder Head and Bonnet).

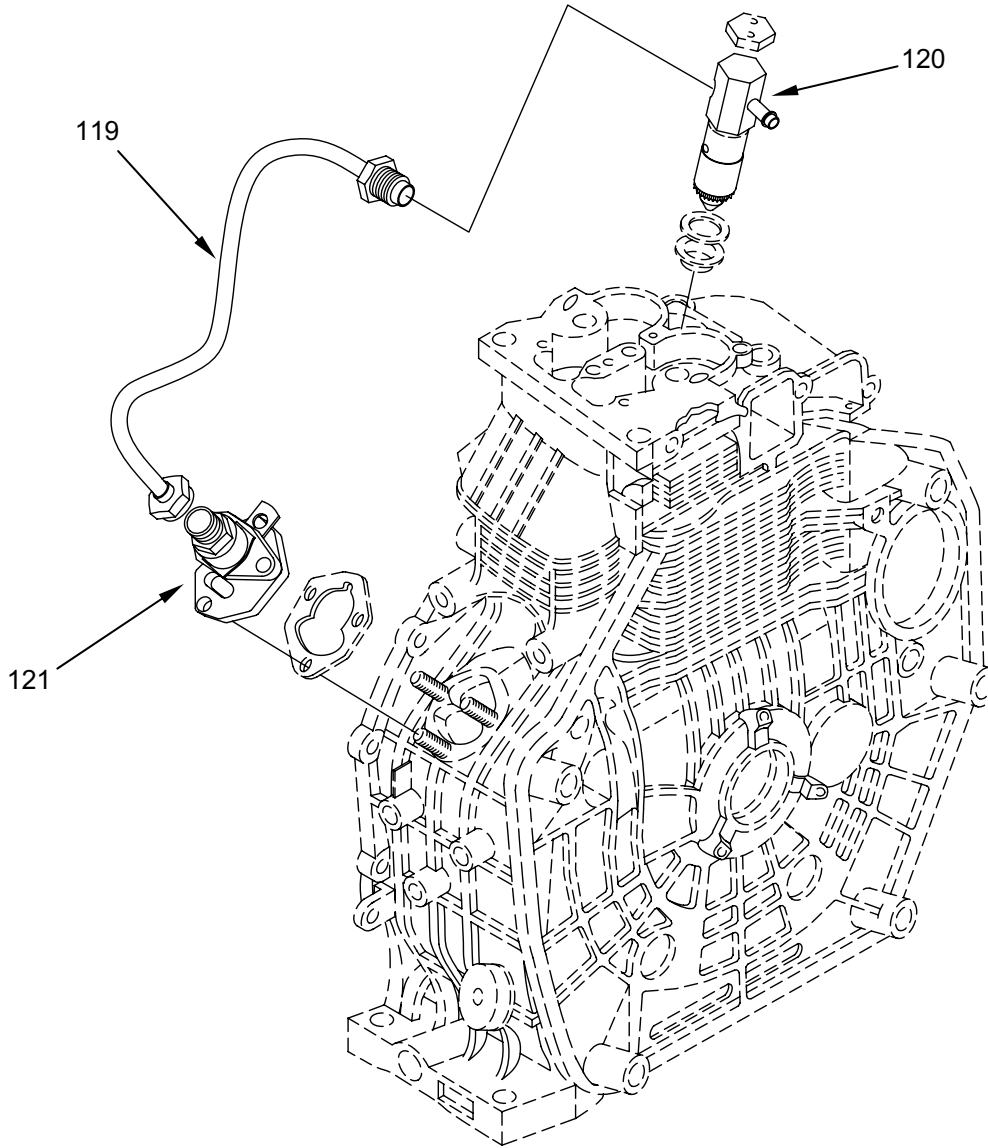

Figure 9. Engine, Diesel (Sheet 6 of 9)
(Fuel Injection Pump).

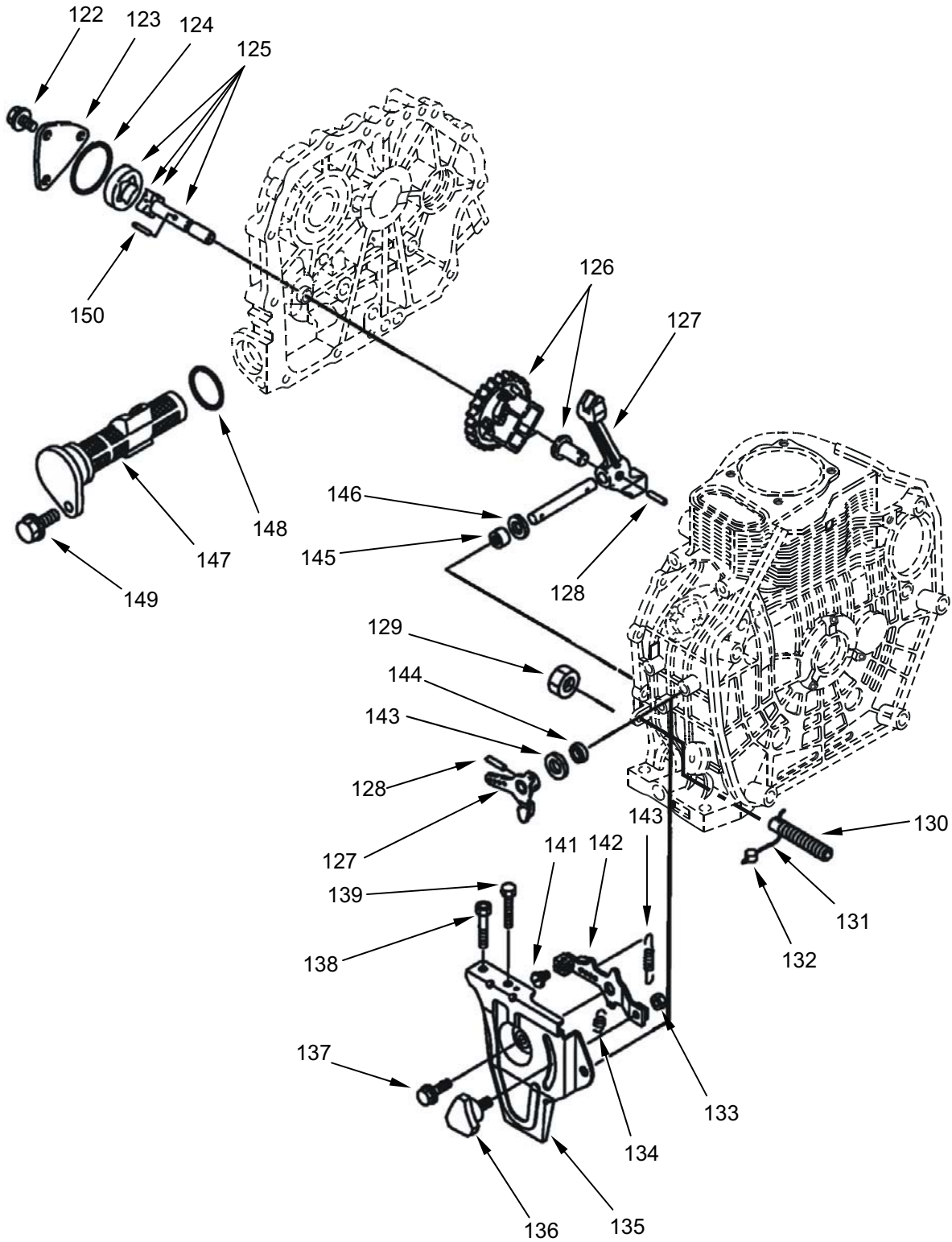

Figure 9. Engine, Diesel (Sheet 7 of 9)
(Lubrication Oil Pump Assembly and Governor).

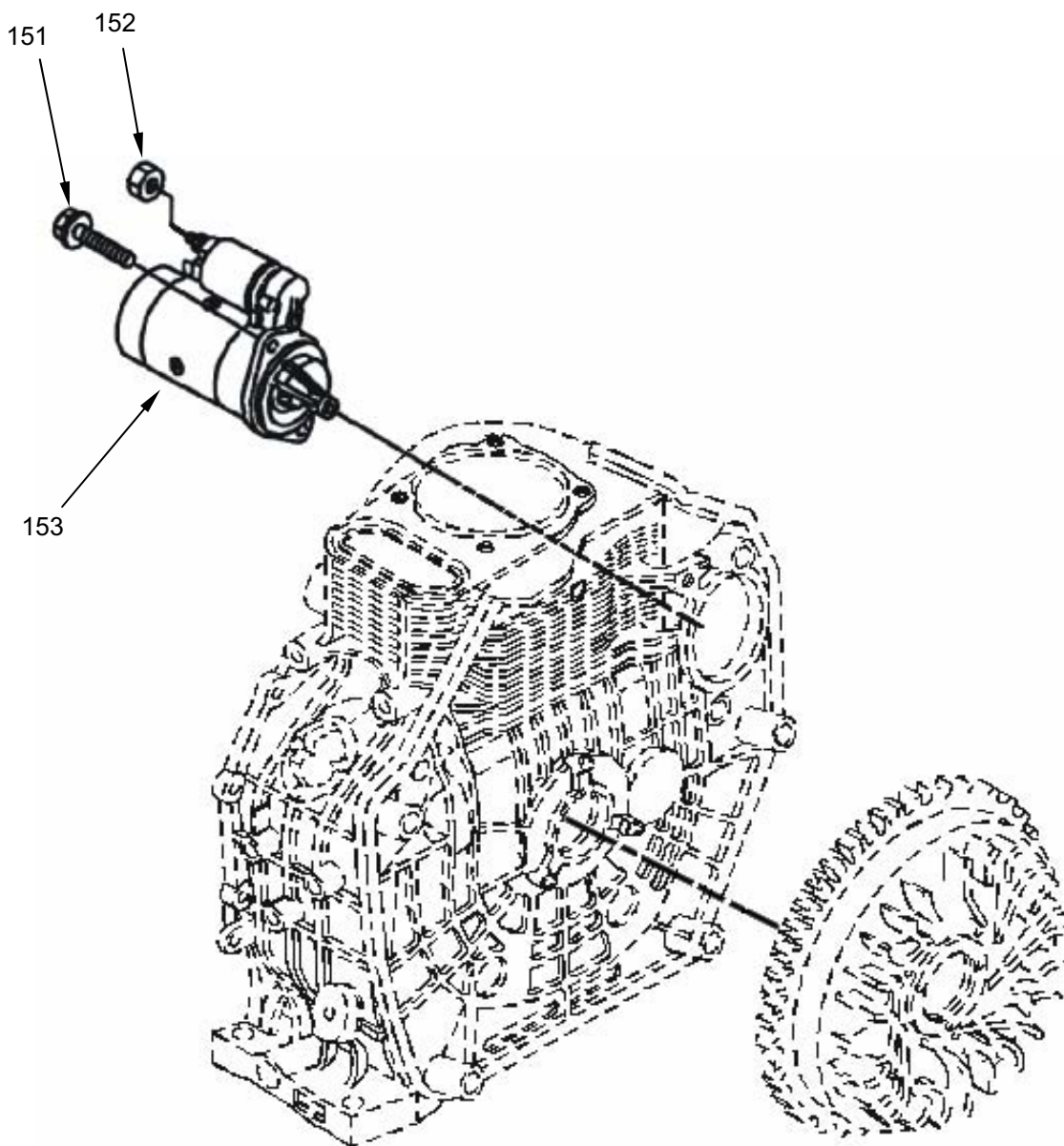

Figure 9. Engine, Diesel (Sheet 8 of 9)
(Starting Motor and Dynamo).

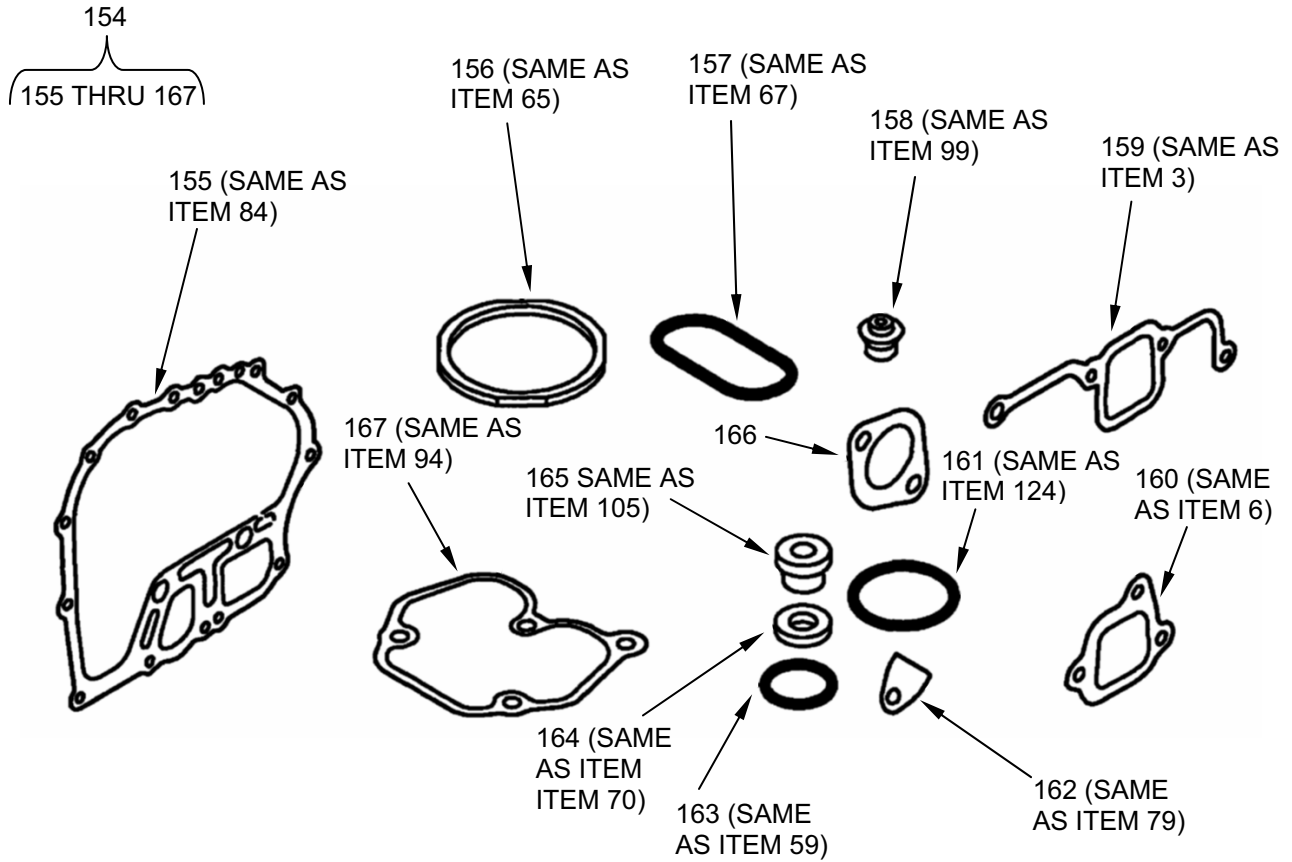

Figure 9. Engine, Diesel (Sheet 9 of 9)
(Gasket Set).

(1)	(2)	(3)	(4)	(5)	(6)	(7)
ITEM NO	SMR CODE	NATIONAL STOCK NUMBER	CAGEC	PART NUMBER	DESCRIPTION AND USABLE ON CODE (UOC)	QTY
					GROUP 03	
					FIG. 9 ENGINE, DIESEL	
1	PAFHH	2815-01-539-8274	92878	40101	ENGINE, DIESEL	1
2	PAOZZ	5307-01-323-5504	0AK42	26226-060552	• STUD, PLAIN	2
3	PAOZZ	5330-01-466-0701	0AK42	114350-12202	• GASKET	1
4	XDOZZ		S4163	114399-12011	• PIPE, INTAKE	1
5	PAOZZ	5307-01-323-5505	0AK42	26226-060142	• STUD, PLAIN, M6 X 14 PLATED	3
6	PAOZZ	5330-01-526-5104	0AK42	114250-12211	• GASKET	1
7	PAOZZ	5365-01-419-5477	0AK42	183375-77560	• SPACER, PLATE	1
8	PAOZZ	5310-01-388-8826	0AK42	26366-060002	• NUT, PLAIN, HEXAGON.....	3
9	PAOZZ	5330-01-477-4043	0AK42	129100-77510	• GASKET	3
10	PAOZZ	4520-01-424-6353	0AK42	129400-77501	• HEATING ELEMENT,ELECTRICAL,NONIM.....	2
11	XDOZZ		0AK42	183375-77570	• ADAPTER	1
12	PAOZZ	5310-01-477-0607	0AK42	22217-080000	• WASHER, FLAT	4
13	PAOZZ	5305-01-477-3508	0AK42	26106-080552	• SCREW, CAP, HEXAGON HEAD	4
14	PAOZZ	2940-01-323-3289	0AK42	714250-12560	• AIR CLEANER, INTAKE.....	1
15	PAOZZ	2940-01-389-9942	0AK42	114250-12530	• • CASE, AIR CLEANER INTAKE.....	1
16	PAOZZ	5310-01-327-0778	0AK42	114250-12550	• • NUT, WING	1
17	PAOZZ	5310-01-322-8747	0AK42	114250-12560	• • WASHER, SEAL	1
18	PAOZZ	5340-01-323-7879	0AK42	114250-12520	• • COVER, ACCESS.....	1
19	PAOZZ	2940-01-310-4495	0AK42	114250-12581	• • FILTER ELEMENT, INTAKE AIR CLEANER	1
20	PAOZZ	5310-01-477-0603	S4163	22217-060000	• WASHER, FLAT	2
21	PAOZZ	5310-01-477-0606	S4163	26716-060002	• NUT, PLAIN, HEXAGON.....	2
22	PAOZZ	5305-01-255-6548	70655	10512	• SCREW, CAP, HEXAGON HEAD	1
23	PAOZZ	2990-01-539-8276	0AK42	114368-13500	• MUFFLER, EXHAUST-INTAKE.....	1
24	PAOZZ	5340-01-433-5460	0AK42	114250-76600	• PLUNGER, DETENT.....	1
25	PAOZZ	5340-01-449-3915	0AK42	114250-76610	• PLUNGER, QUICK RELEASE	1
26	XDOZZ		0AK42	114370-45351	• BOLT, HEX HEAD.....	4
27	PAOZZ	5342-01-323-7866	0AK42	114250-45310	• COUPLING, CLAMP, GROOVED	4
28	PAOZZ	5340-01-526-5277	0AK42	114250-45301	• BUMPER, NON METALLIC.....	4
29	XDOZZ		0AK42	114360-45101	• CASE, FAN, NONAIRCRAFT GAS TURBINE ENGINE	1
30	PAOZZ	5330-01-330-9564	0AK42	114250-45330	• SEAL, PLAIN ENCASED.....	1
31	PAHZZ	3110-01-322-9532	0AK42	24101-062024	• BEARING, BALL, ANNULAR	2
32	XDHZZ		0AK42	714350-28520	• BALANCER SHAFT ASSEMBLY	1
33	PAHZZ	2910-01-465-8277	S4163	22252-000210	• CLAMP	2
34	PAHZZ	2815-01-530-1527	0AK42	714872-22720	• PISTON, INTERNAL COM.....	1

(1)	(2)	(3)	(4)	(5)	(6)	(7)
ITEM NO	SMR CODE	NATIONAL STOCK NUMBER	CAGEC	PART NUMBER	DESCRIPTION AND USABLE ON CODE (UOC)	QTY
35	PAHZZ	2815-01-477-0536	0AK42	714870-22500	• • RING SET, PISTON	1
36	PAHZZ	2815-01-465-6393	0AK42	114399-22300	• PIN, PISTON	1
37	PAHZZ	2805-01-465-7528	0AK42	714380-23700	• CONNECTING ROD, PISTON	1
38	PAHZZ	3110-01-530-1167	0AK42	714380-23600	• • BEARING, BALL, ANNULAR	1
39	XDHZZ		0AK42	714380-23620	• • BEARING, SLEEVE U.S.=0.50	1
40	XDHZZ		0AK42	714380-23610	• • BEARING, SLEEVE U.S.=0.25	1
41	XAHZZ		0AK42	114380-23100	• • BUSHING, PISTON PIN.....	1
42	XAHZZ		0AK42	118200-23200	• • BOLT, MACHINE	2
43	PAHZZ	5305-01-465-9934	0AK42	160842-21150	• KEY, MACHINE.....	1
44	PAHZZ	5315-01-432-1210	0AK42	22512-040120	• KEY, MACHINE.....	1
45	PAHZZ	2815-01-465-6703	S4163	114881-21590	• FLYWHEEL, ENGINE	1
46	PAHZZ	5310-01-431-4070	0AK42	114250-21550	• FLAT WASHER.....	1
47	PAHZZ	5310-01-398-0737	0AK42	103854-01221	• NUT, PLAIN, HEXAGON.....	1
48	PAHZZ	2815-01-465-9578	0AK42	114350-14450	• ROD, PUSH	2
49	PAHZZ	2815-01-323-0352	0AK42	114250-14200	• TAPPET, ENGINE POPPET VALVE.....	2
50	PAHZZ	2815-01-465-9616	S4163	714880-14580	• CAMSHAFT, ENGINE	1
51	PAHZZ	2815-01-323-0353	0AK42	114771-14260	• TAPPET, ENGINE POPPET VALVE.	1
52	XDHZZ		0AK42	714876-21730	• CRANKSHAFT, ENGINE	1
53	PAHZZ	5310-01-466-4888	0AK42	160842-21260	• WASHER, FLAT	1
54	PAHZZ	5306-01-471-6051	0AK42	160842-21250	• BOLT, MACHINE.....	1
55	PAHZZ	5330-01-324-8254	0AK42	160110-02220	• SEAL, PLAIN, ENCASED.....	1
56	PAHZZ	5306-01-431-7461	0AK42	26106-080352	• BOLT, MACHINE.....	15
57	PAHZZ	5315-98-205-1859	0AK42	114270-01600	• PIN, STRAIGHT, HEADLESS	2
58	PAHZZ	5342-01-415-3792	0AK42	114699-01760	• CAP, FILLER OPENING	2
59	PAHZZ	5331-01-323-2728	0AK42	24311-000180	• • O-RING	2
60	PAHZZ	5310-01-477-0596	S4163	105225-01240	• WASHER, FLAT.....	4
61	PAHZZ	5310-01-477-0592	S4163	114350-01250	• NUT, PLAIN, HEXAGON.....	2
62	PAHZZ	5310-01-477-0582	0AK42	114350-01220	• NUT, PLAIN, HEXAGON.....	2
63	PAHZZ	5307-01-477-4029	S4163	114350-01200	• STUD, PLAIN	2
64	PAHZZ	5307-01-477-4022	S4163	114350-01210	• STUD, PLAIN	2
65	PAHZZ	5330-01-530-6327	0AK42	114871-01330	• GASKET.....	1
66	PAHZZ	5340-98-205-1855	0AK42	114350-01700	• COVER, ACCESS.....	1
67	PAHZZ	5331-01-466-0712	0AK42	114350-01380	• O-RING	1
68	PAHZZ	5315-01-526-8491	0AK42	22312-040080	• PIN, STRAIGHT HEADLE.....	2
69	PAHZZ	2815-01-524-7056	0AK42	714871-01560	• ENGINE BLOCK, DIESEL.....	1
70	PAHZZ	5330-01-326-2669	0AK42	22190-160002	• GASKET.....	2
71	PAHZZ	4730-01-322-4956	0AK42	105425-01690	• PLUG, PIPE	2
72	PAHZZ	5330-01-324-8254	0AK42	160110-02220	• SEAL, PLAIN ENCASED.....	1
73	PAHZZ	5307-14-469-7400	S4163	26226-060182	• STUD, PLAIN	1

(1)	(2)	(3)	(4)	(5)	(6)	(7)
ITEM NO	SMR CODE	NATIONAL STOCK NUMBER	CAGEC	PART NUMBER	DESCRIPTION AND USABLE ON CODE (UOC)	QTY
74	PAHZZ	5307-14-469-7440	S4163	26226-060222	• STUD, PLAIN	2
75	PAHZZ	5365-01-415-6744	0AK42	114250-01800	• SHIM SET	1
76	PAHZZ	5306-98-205-1856	S4163	26106-100122	• BOLT, ASSEMBLED WASHER.....	2
77	PAHZZ	5310-01-388-8826	0AK42	26366-060002	• NUT, PLAIN, HEXAGON.....	3
78	PAHZZ	3110-01-324-8817	0AK42	24162-152112	• BEARING, ROLLER, NEEDLE.....	1
79	PAHZZ	5330-01-328-4171	0AK42	114250-01841	• GASKET.....	1
80	PAHZZ	5340-01-415-3789	0AK42	114250-01830	• COVER, ACCESS.....	1
81	PAHZZ	3110-01-465-3598	0AK42	114350-02113	• BALL BEARING.....	1
82	PAHZZ	4820-01-526-7409	0AK42	114299-02030	• RETAINER, DISK, VALVE	1
83	PAHZZ	5305-14-469-7436	S4163	26106-080122	• SCREW	1
84	PAHZZ	5330-01-466-0713	0AK42	114350-01412	• GASKET	1
85	PAHZZ	5310-01-477-3930	S4163	114250-35150	• PIPE, L.O. INLET	1
86	XDHZZ		0AK42	114368-01453	• CRANKCASE COVER	1
87	PAHZZ	3110-01-465-3473	0AK42	114350-02100	• • BEARING, BALL ANNULAR	1
87	XDHZZ		0AK42	114350-02200	• • MAIN BEARING 0.25	1
87	XDHZZ		0AK42	114350-02210	• • MAIN BEARING 0.50	1
88	PAOZZ	5365-01-526-7332	0AK42	23876-010000	• PLUG, MACHINE THREAD	1
89	PAOZZ	4810-01-526-5186	0AK42	114771-11950	• COVER PLATE, VALVE.....	1
90	PAOZZ	3040-01-323-3294	0AK42	114250-03591	• • LEVER, REMOTE CONTROL.....	1
91	PAOZZ	5360-01-322-8623	0AK42	114250-03640	• • SPRING, HELICAL, COMPRESSION.....	1
92	PAOZZ	5315-01-431-8229	15852	2BE10YDN TABLE 7-3 REF 37	• • PIN, STRAIGHT, HEADLESS	1
93	PAOZZ	5306-01-323-5440	0AK42	26106-060552	• BOLT, MACHINE.....	3
94	PAOZZ	5330-01-526-5339	0AK42	114771-11310	• GASKET	1
95	PAFZZ	4820-01-477-0283	0AK42	105010-11490	• CAP, VALVE	2
96	PAFZZ	2815-01-465-6745	S4163	27310-060001	• COTTER ASSEMBLY	2
97	PAFZZ	5340-01-470-3631	0AK42	101158-11180	• RETAINER, HELICAL COMPRESSION SPRING.....	2
98	PAFZZ	5360-01-477-0602	0AK42	114350-11120	• SPRING, HELICAL COMPRESSION....	2
99	PAFZZ	4820-01-477-0277	0AK42	114350-11340	• SEAL, VALVE.....	2
100	PAFZZ	5310-01-431-4064	0AK42	114250-11600	• WASHER, FLAT.....	2
101	PAFZZ	5310-01-388-8826	0AK42	26366-060002	• NUT, PLAIN, HEXAGON.....	2
102	PAFZZ	2815-01-324-6801	0AK42	114250-11901	• RETAINER, DIESEL ENGINE.....	1
103	XDFZZ		0AK42	26226-060602	• STUD, PLAIN	2
104	PAFZZ	5365-01-486-3251	0AK42	114771-11470	• SPACER, SLEEVE.....	1
105	PAFZZ	5330-01-486-4449	0AK42	114771-11461	• GASKET.....	1
106	PAFZZ	2815-01-530-1259	0AK42	114871-11100	• VALVE, POPPET, ENGINE.....	1
107	PAFZZ	2815-01-530-1293	0AK42	114871-11110	• VALVE, POPPET, ENGINE.....	1
108	PAFZZ	2815-01-530-1252	0AK42	114871-11020	• CYLINDER HEAD, DIESEL ENGINE....	1
109	PAFZZ	5315-01-431-8230	15852	2BE10YDN TABLE 7-3 REF 26	• PIN, SPRING.....	1
110	PAFZZ	2815-01-526-5197	0AK42	114771-11250	• ROCKER ARM ASSEMBLY.....	1

(1)	(2)	(3)	(4)	(5)	(6)	(7)
ITEM NO	SMR CODE	NATIONAL STOCK NUMBER	CAGEC	PART NUMBER	DESCRIPTION AND USABLE ON CODE (UOC)	QTY
111	XDFZZ		0AK42	22242-000120	• • RING, RETAINING.....	2
112	PAFZZ	2815-01-416-3333	0AK42	114250-11240	• • SCREW, VALVE, ADJUSTING TAPPET	1
113	XDFZZ		0AK42	114771-11660	• • ROCKER ARM, ENGINE POPPET VALVE.....	1
114	XDFZZ		0AK42	26856-060002	• • NUT, SELF-LOCKING, EXTENDED WASHER HEXAGON.....	1
115	PAFZZ	5305-14-469-8502	S4163	26106-060452	• • SCREW.....	2
116	XDFZZ		0AK42	114771-11260	• • BRACKET, ROCKER ARM ENGINE POPPET VALVE.....	1
117	XDFZZ		0AK42	114771-11650	• • ROCKER ARM, ENGINE POPPET VALVE.....	1
118	PAFZZ	2815-01-416-3333	0AK42	114250-11240	• • SCREW, VALVE, ADJUSTING TAPPET	1
119	XDOZZ		0AK42	114871-59802	• TUBE ASSEMBLY, METAL.....	1
120	PAOZZ	2910-01-530-0758	0AK42	714871-53100	• INJECTOR ASSEMBLY, FUEL	1
121	PAFHH	2910-01-530-0749	0AK42	714650-51100	• PUMP, FUEL, CAM ACTUATED.....	1
122	PAOZZ	5306-01-388-7402	0AK42	26476-060142	• BOLT, MACHINE.....	3
123	PAOZZ	5340-01-433-5457	0AK42	114250-32070	• COVER, ACCESS.....	1
124	PAOZZ	5331-01-324-8279	0AK42	103338-32570	• O-RING	1
125	PAFZZ	4320-01-323-0298	0AK42	114250-32010	• PUMP, ROTARY	1
126	XDFZZ		0AK42	714770-61100	• GOVERNOR ASSEMBLY, CONSTANT SPEED DRIVE.....	1
127	PAFZZ	2990-01-465-5995	S4163	714350-61500	• LEVER ASSY, POWER-SPEED CONTROL.....	1
128	XDFZZ		0AK42	22322-030200	• • PIN, TAPERED, PLAIN	1
129	PAFZZ	5310-01-431-4066	0AK42	26696-100002	• NUT, PLAIN, HEXAGON.....	1
130	XDFZZ		0AK42	114871-66550	• SPRING, SPIRAL, TORSION.....	1
131	PAFZZ	4320-01-457-0232	15852	22451-060000	• 0.6 WIRE	2
132	PAFZZ	5340-01-433-5458	0AK42	135210-61090	• WIRE, LOCKING, ANTIPILFERAGE SEAL	2
133	PAOZZ	5310-01-526-8383	0AK42	26347-060002	• NUT, SELF-LOCKING, HEXAGON	1
134	PAFZZ	5360-01-322-8631	0AK42	114250-66200	• SPRING, HELICAL, EXTENDED	1
135	XDFZZ		0AK42	114299-66100	• STAY, HANDLE.....	1
136	PAFZZ	5340-01-433-5456	0AK42	160725-78350	• HANDLE, MANUAL CONTROL (W/M6 X 15).....	1
137	PAFZZ	5306-01-526-7343	0AK42	26106-060142	• BOLT, MACHINE.....	1
138	PAFZZ	5306-01-431-7459	0AK42	114250-66440	• BOLT, MACHINE.....	1
139	PAFZZ	5305-01-431-9398	0AK42	102100-67080	• SETSCREW	1
140	PAFZZ	5306-01-526-7950	0AK42	26117-040088	• BOLT, MACHINE.....	1
141	PAFZZ	5340-01-430-4761	S4163	114250-66050	• HANDLE, MANUAL CONTROL.....	1
142	PAFZZ	5360-01-477-0601	0AK42	114870-66010	• SPRING, CONSTANT FORCE	1
143	PAFZZ	3010-01-389-9003	0AK42	114770-61610	• THRUST PLATE, TRANSMISSION	1
144	PAFZZ	5330-01-415-3802	0AK42	114770-61600	• SEAL, PLAIN ENCASED.....	1
145	XDFZZ		0AK42	114770-61520	• RETAINER, ROLLER, BEARING.....	2

(1) ITEM NO	(2) SMR CODE	(3) NATIONAL STOCK NUMBER	(4) CAGEC	(5) PART NUMBER	(6) DESCRIPTION AND USABLE ON CODE (UOC)	(7) QTY
146	XDFZZ		0AK42	114770-61190	• WASHER, FLAT.....	1
147	PAOZZ	2815-01-353-7523	0AK42	114250-35110	• STRAINER, OIL PUMP	1
148	PAOZZ	5331-01-326-8017	0AK42	24341-000224	• • O-RING	1
149	PAOZZ	5305-01-388-6229	0AK42	26106-060162	• SCREW, CAP, HEXAGON HEAD.....	1
150	PAFZZ	5315-01-431-8229	15852	2BE10YDN TABLE 7-3 REF 37	• PIN, STRAIGHT, HEADLESS	1
151	PAOZZ	5306-01-431-7460	0AK42	26106-100302	• BOLT, MACHINE.....	2
152	XDOZZ		0AK42	26716-080002	• NUT, PLAIN, HEXAGON.....	1
153	PAOZZ	2920-01-452-8409	0AK42	114362-77990	• STARTER, ENGINE ELECTRIC	1
154	PAHZZ	5330-01-530-6424	0AK42	714871-92600	• GASKET SET.....	1
155	PAHZZ	5330-01-466-0713	0AK42	114350-01412	• • GASKET.....	1
156	PAHZZ	5330-01-530-6327	0AK42	114871-01330	• • GASKET.....	1
157	PAHZZ	5331-01-466-0712	0AK42	114350-01380	• • O-RING	1
158	PAFZZ	4820-01-477-0277	0AK42	114350-11340	• • SEAL, VALVE.....	2
159	PAOZZ	5330-01-466-0701	0AK42	114350-12202	• • GASKET.....	1
160	XDOZZ	5330-01-526-5104	0AK42	114250-12211	• • GASKET.....	1
161	PAOZZ	5331-01-324-8279	0AK42	103338-32570	• • O-RING	1
162	PAHZZ	5330-01-328-4171	0AK42	114250-01841	• • GASKET.....	1
163	PAHZZ	5331-01-323-2728	0AK42	24311-000180	• • O-RING	2
164	PAHZZ	5330-01-326-2669	0AK42	22190-160002	• • GASKET.....	2
165	PAHZZ	5330-01-486-4449	0AK42	114771-11461	• • GASKET.....	1
166	PAOZZ	5330-01-326-4780	0AK42	114250-13201	• • GASKET.....	1
167	PAOZZ	5330-01-526-5339	0AK42	114771-11310	• • GASKET.....	1

END OF FIGURE

OPERATOR, FIELD AND SUSTAINMENT MAINTENANCE

LARGE CAPACITY FIELD HEATER (LCFH)

HEAT EXCHANGER
40370

REPAIR PARTS LIST

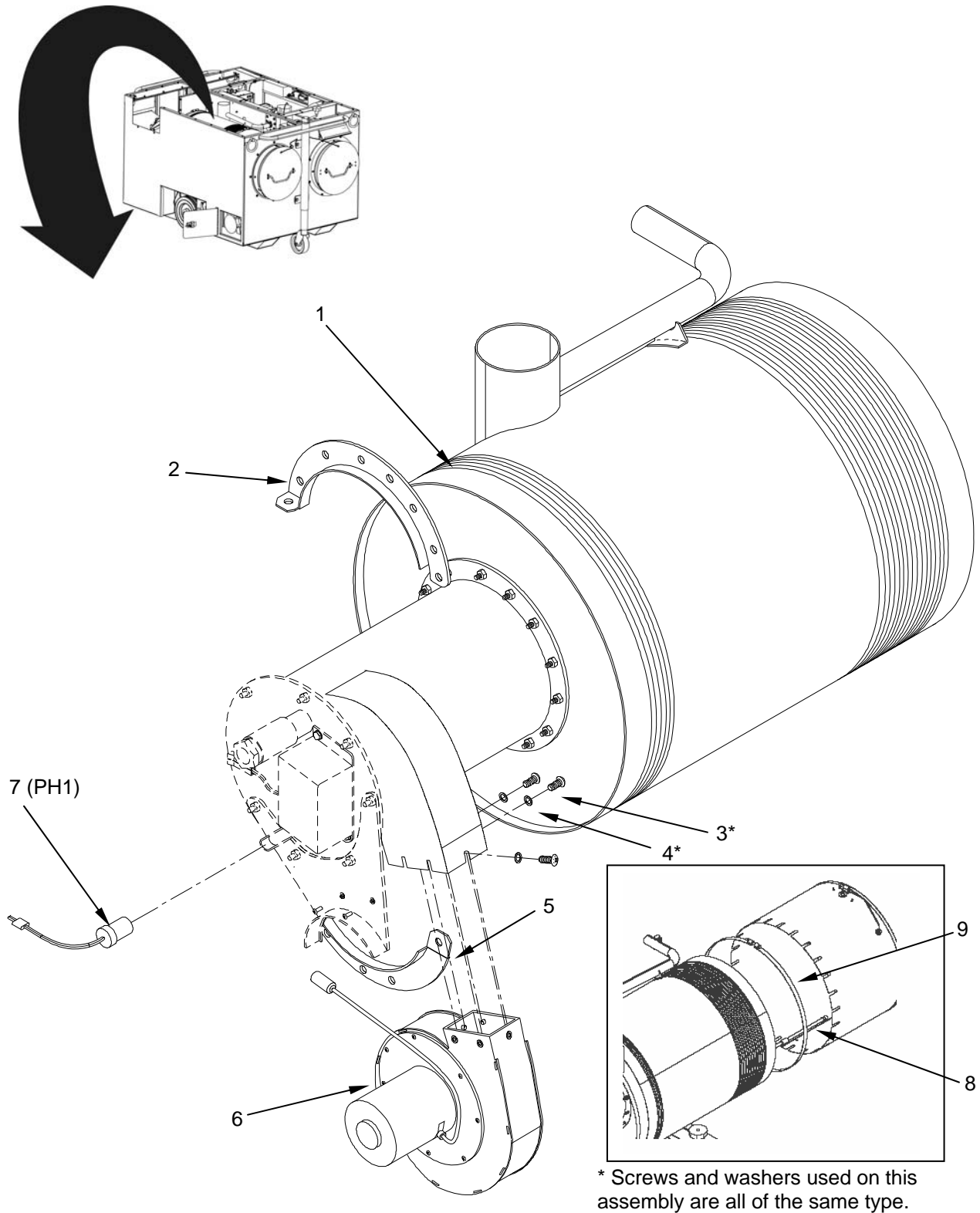

Figure 10. Heat Exchanger

(1)	(2)	(3)	(4)	(5)	(6)	(7)
ITEM NO	SMR CODE	NATIONAL STOCK NUMBER	CAGEC	PART NUMBER	DESCRIPTION AND USABLE ON CODE (UOC)	QTY
					GROUP 04	
					FIG. 10 HEAT EXCHANGER	
1	XDOZZ		92878	40370	HEAT EXCHANGER.....	1
2	XDOZZ		92878	40320	. BRACKET, MOUNTING.....	1
3	PAOZZ	5305-00-984-6210	96906	MS35206-263	. SCREW, MACHINE	6
4	PAOZZ	5310-00-014-5850	96906	MS27183-42	. WASHER, FLAT.....	6
5	XDOZZ		92878	40321	. BRACKET, MOUNTING.....	1
6	PAOZZ	4520-01-539-8277	92878	40310	. ASSY, COMBUSTION BLOWER.....	1
7	PAOZZ	4520-01-539-7201	92878	40484	. FLAME SENSOR	1
8	XDOZZ		92878	40325	. TUBE ASSEMBLY, METAL	1
9	XDOZZ		92878	40301	. STRAP, RETAINING.....	1
					END OF FIGURE	

OPERATOR, FIELD AND SUSTAINMENT MAINTENANCE

LARGE CAPACITY FIELD HEATER (LCFH)

ASSEMBLY, IGNITION

40304

REPAIR PARTS LIST

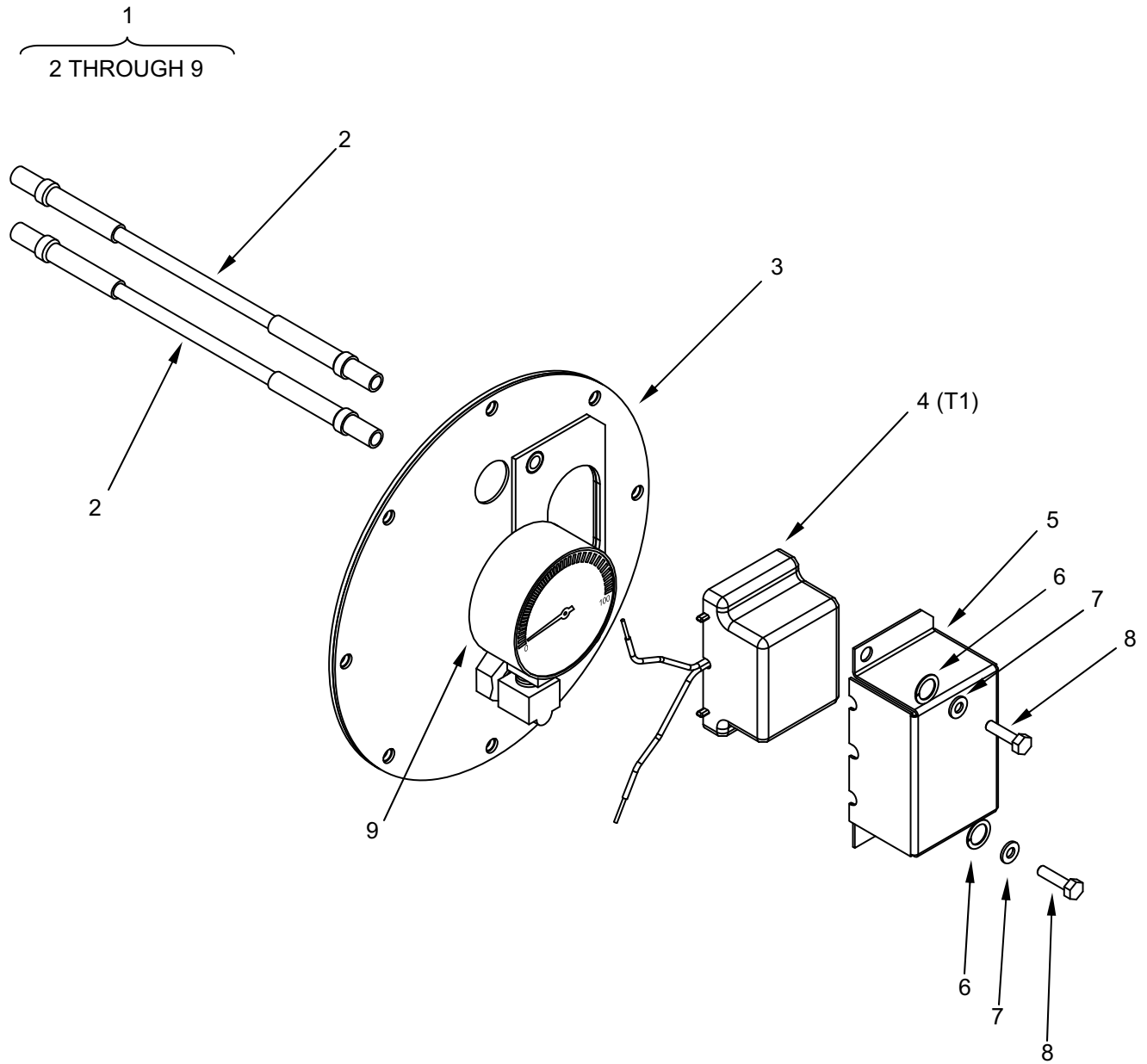

Figure 11. Assembly, Ignition.

(1)	(2)	(3)	(4)	(5)	(6)	(7)
ITEM NO	SMR CODE	NATIONAL STOCK NUMBER	CAGEC	PART NUMBER	DESCRIPTION AND USABLE ON CODE (UOC)	QTY
					GROUP 04	
					FIG. 11 ASSEMBLY, IGNITION	
1	XDOOO		92878	40304	ASSEMBLY, IGNITION	1
2	PAOZZ	2910-01-539-7165	92878	75088-100	• LEAD, IGNITION	2
3	XDOZZ		92878	75150	• PLATE, IGNITION	1
4	PAOZZ	2920-01-539-7163	92878	6174	• DISTRIBUTOR, IGNITION SYSTEM.....	1
5	XDOZZ		92878	75086	• BRACKET, MOUNTING	1
6	PAOZZ	5310-00-582-5965	99539	CBM21389	• WASHER, LOCK.....	2
7	PAOZZ	5310-00-809-4058	96906	MS27183-10	• WASHER, FLAT	2
8	PAOZZ	5305-00-225-3843	80204	B1821BH025C1 00N	• SCREW, CAP, HEXAGON, HEAD	2
9	PAOZZ	6685-01-048-4144	14449	TL20P-M 0- 100BE NONMAG	• GAGE, PRESSURE, DIAL INDICATING.....	1
					END OF FIGURE	

OPERATOR, FIELD AND SUSTAINMENT MAINTENANCE

LARGE CAPACITY FIELD HEATER (LCFH)

ASSEMBLY, BURNER NOZZLE

40302-02

REPAIR PARTS LIST

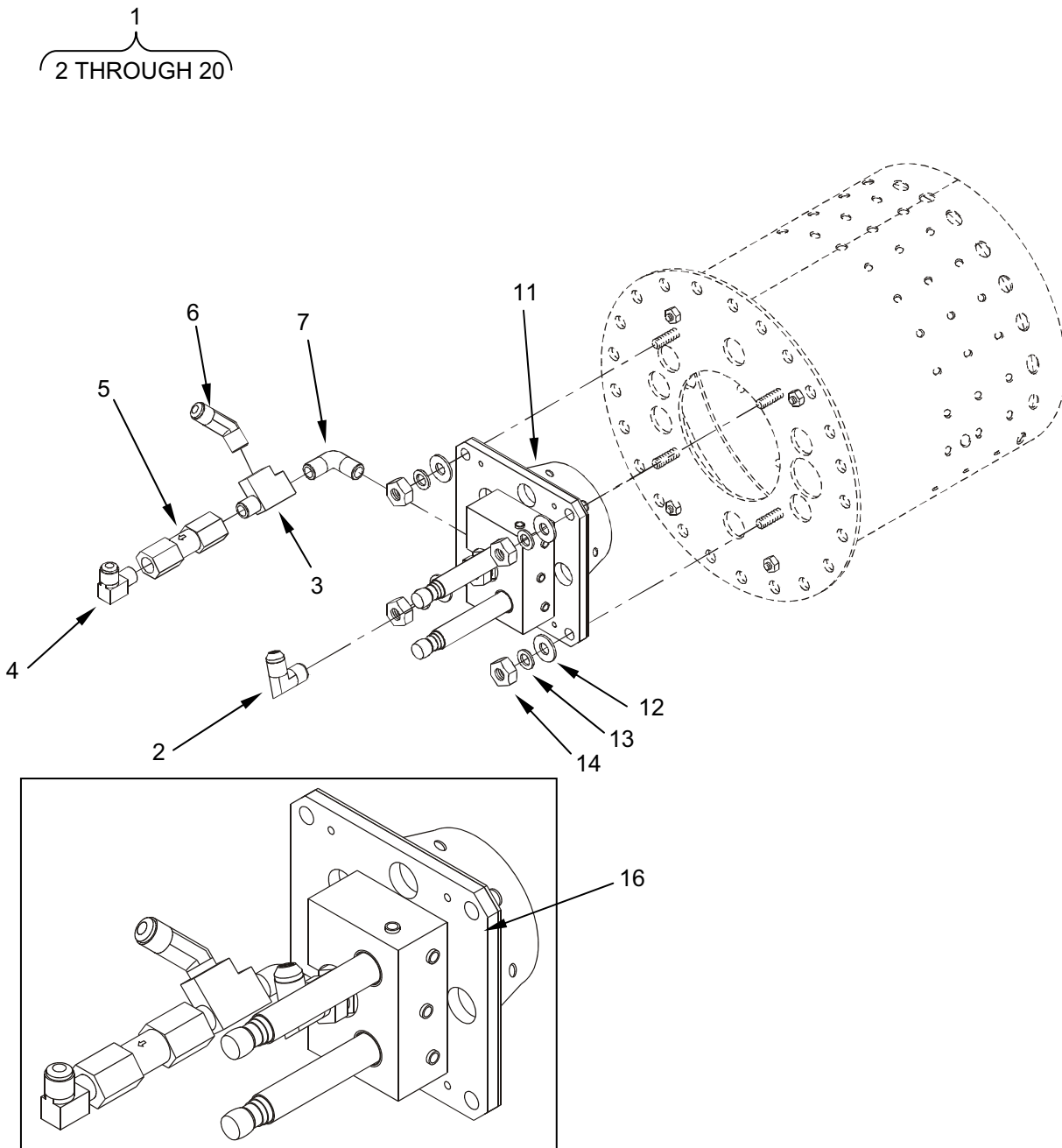

Figure 12. Assembly, Burner Nozzle (Sheet 1 of 2).

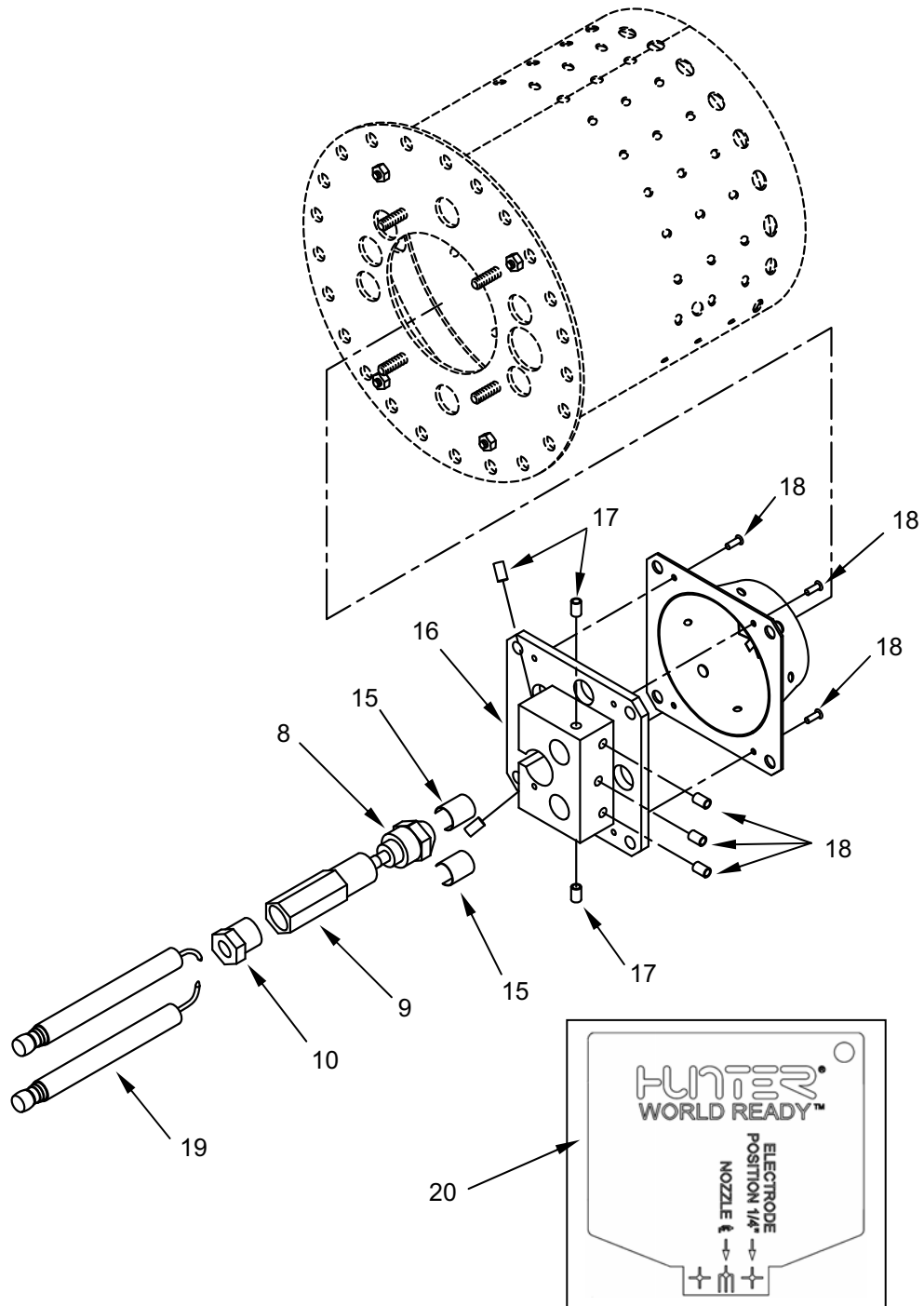

Figure 12. Assembly, Burner Nozzle (Sheet 2 of 2).

(1)	(2)	(3)	(4)	(5)	(6)	(7)
ITEM NO	SMR CODE	NATIONAL STOCK NUMBER	CAGEC	PART NUMBER	DESCRIPTION AND USABLE ON CODE (UOC)	QTY
GROUP 04						
FIG. 12 ASSEMBLY, BURNER NOZZLE						
1	XCOOO		92878	40302-02	ASSEMBLY, BURNER NOZZLE	1
2	PAOZZ	4730-01-421-9277	96906	MS51504A3Z	• ELBOW, TUBE	1
3	XDOZZ		92878	40243	• TEE, PIPE	1
4	PAOZZ	4730-00-647-3207	96906	MS51504A4	• ELBOW, PIPE TO TUBE	1
5	XDOZZ		92878	40352	• RESTRICTOR, FLOW	1
6	PAOZZ	4730-00-995-1568	96906	MS51508A4Z	• ELBOW, PIPE TO TUBE	1
7	PAOZZ	4730-00-566-1296	96906	2-2 140237C	• ELBOW, TUBE	1
8	PAOZZ	2910-01-539-7166	92878	40247	• NOZZLE, FUEL INJECTION, NONAIRCRAFT	1
9	XDOZZ		92878	40245	• ADAPTER, PRESSURE FUEL SERVICING	1
10	PAOZZ	4370-00-014-1539	72582	0112877	• ADAPTER, BUSHING	1
11	XDOZZ		92878	40249	• NOZZLE, CONE ASSY	1
12	PAOZZ	5310-00-582-5677	80205	MS15795-810	• WASHER, FLAT	4
13	PAOZZ	5310-00-883-9417	96906	MS35338-158	• WASHER, LOCK	4
14	PAOZZ	5310-00-855-1102	96906	MS35649-2255	• NUT, PLAIN, HEXAGON	4
15	PAOZZ	5975-01-092-8655	50340	12408	• BUSHING, ELECTRICAL CONDUCTOR	2
16	XDOZZ		92878	40357	• HOLDER, NOZZLE	1
17	PAOZZ	5305-00-724-5851	80205	M551029-53	• SET SCREW	7
18	PAOZZ	5305-00-765-4257	80205	MS51959-43	• SCREW, MACHINE	4
19	PAOZZ	5977-01-280-0378	0D0F2	13300-100	• ELECTRODE	2
20	XDOZZ		92878	40790	• ADJUSTER, SPARK GAP ELECTRODE	1
END OF FIGURE						

OPERATOR, FIELD AND SUSTAINMENT MAINTENANCE

LARGE CAPACITY FIELD HEATER (LCFH)

BURNER ASSEMBLY

40035

REPAIR PARTS LIST

NOTE: All lock washers (9), flat washers (8), and hex nuts (10) are of the same type throughout the assembly.

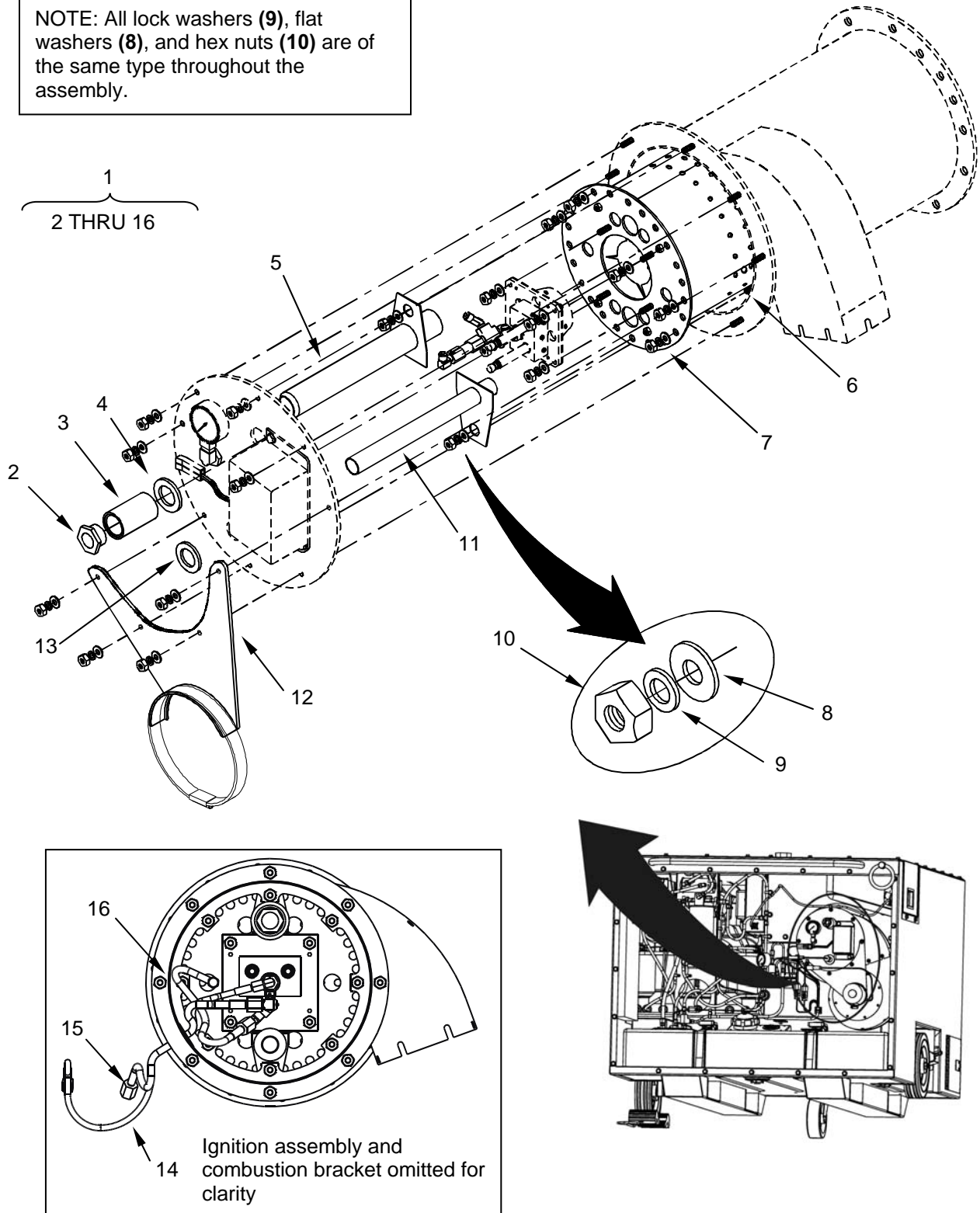

Figure 13. Burner Assembly
0106 00-2

(1)	(2)	(3)	(4)	(5)	(6)	(7)
ITEM NO	SMR CODE	NATIONAL STOCK NUMBER	CAGEC	PART NUMBER	DESCRIPTION AND USABLE ON CODE (UOC)	QTY
GROUP 04						
FIG. 13 BURNER ASSEMBLY						
1	XDOOO		92878	40035	BURNER ASSEMBLY	1
2	PAOZZ	6680-01-330-0694	12190	PD41024-19	• INDICATOR, SIGHT, LIQUID	1
3	PAOZZ	4730-01-158-6196	81343	J514	• COUPLING, PIPE	1
4	XDOZZ		92878	40362	• GASKET	1
5	XDOZZ		92878	40356	• TUBE, SIGHT GLASS	1
6	PAOZZ	5305-00-702-4523	80205	MS35307-306	• SCREW, CAP, HEX HEAD	4
7	XDOZZ		92878	40350	• BURNER	1
8	PAOZZ	5310-00-582-5677	80205	MS15795-810	• WASHER, FLAT	20
9	PAOZZ	5310-00-883-9417	96906	MS35338-158	• WASHER, LOCK	20
10	PAOZZ	5310-00-855-1102	96906	MS35649-2255	• NUT, PLAIN, HEXAGON	20
11	XDOZZ		92878	40355	• TUBE, FLAME DETECTOR	1
12	XDOZZ		92878	40311	• BRACKET, MOUNTING, COMBUSTION BLOWER	1
13	XDOZZ		92878	40363	• GASKET	1
14	XDOZZ		92878	40250	• HOSE ASSEMBLY, FUEL SUPPLY	1
15	XDOZZ		92878	40251	• HOSE ASSEMBLY, FUEL RETURN	1
16	XDOZZ		92878	40255	• HOSE ASSEMBLY, PRESSURE GAUGE	1
END OF FIGURE						

OPERATOR, FIELD AND SUSTAINMENT MAINTENANCE

LARGE CAPACITY FIELD HEATER (LCFH)

ASSEMBLY, TRANSITION TUBE
40303

REPAIR PARTS LIST

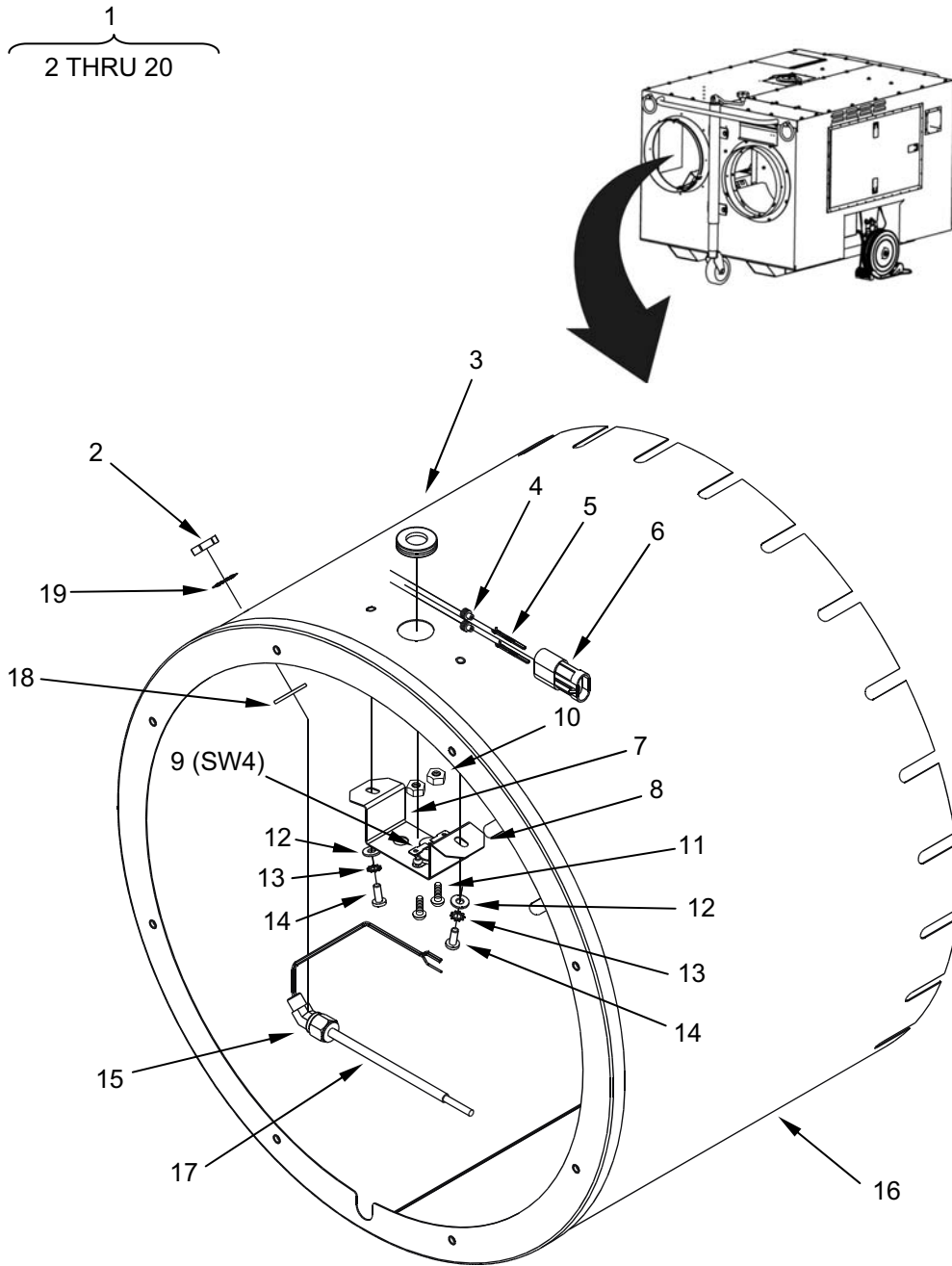

Figure 14. Assembly, Transition Tube.

(1)	(2)	(3)	(4)	(5)	(6)	(7)
ITEM NO	SMR CODE	NATIONAL STOCK NUMBER	CAGEC	PART NUMBER	DESCRIPTION AND USABLE ON CODE (UOC)	QTY
					GROUP 04	
					FIG. 14 ASSEMBLY, TRANSITION TUBE	
1	XDOOO		92878	40303	ASSEMBLY, TRANSITION TUBE	1
2	PAOZZ	4730-00-350-9619	93061	210P-2	• LOCKNUT, PIPE	1
3	PAOZZ	4520-01-492-9125	92878	5914	• GROMMET	1
4	PAOZZ	2530-01-503-5000	77060	12089679	• BOOT, VEHICULAR COMPONENTS	2
5	PAOZZ	5940-01-234-7272	77060	12089040	• PIN TERMINAL	2
6	PAOZZ	5935-01-214-4163	22785	12010973	• CONNECTOR BODY, PLUG, ELECTRICAL	1
7	XDOZZ		92878	40331	• ASSY, OUTLET SENSOR BRACKET	1
8	XDOZZ		92878	40332	• • BRACKET, MOUNTING	1
9	PAOZZ	5930-01-539-7169	92878	40482	• • SWITCH, THERMOSTATIC	1
10	PAOZZ	5310-00-081-8087	80205	MS21044N06	• • NUT, SELF-LOCKING, HEXAGON	2
11	PAOZZ	5305-00-984-4984	80205	MS35206-227	• • SCREW, MACHINE	2
12	PAOZZ	5310-00-014-5850	96906	MS27183-42	• WASHER, FLAT	2
13	PAOZZ	5310-00-596-7691	96906	MS35335-32	• WASHER, LOCK	2
14	PAOZZ	5305-00-984-6210	96906	MS35206-263	• SCREW, MACHINE	2
15	PAOZZ	4730-01-534-4664	39428	50385K31	• ELBOW, PIPE	1
16	XDOZZ		92878	40333	• TUBE, TRANSITION	1
17	PAOZZ	6685-01-539-7173	92878	40481	• SENSOR, OUTLET TEMPERATURE	1
18	PAOZZ	5310-00-829-4061	96906	MS27183-15	• WASHER, FLAT	1
19	PAOZZ	5310-00-685-3228	96906	MS35333-43	• WASHER, LOCK	1
					END OF FIGURE	

OPERATOR, FIELD AND SUSTAINMENT MAINTENANCE

LARGE CAPACITY FIELD HEATER (LCFH)

BATTERY, STORAGE

40600

REPAIR PARTS LIST

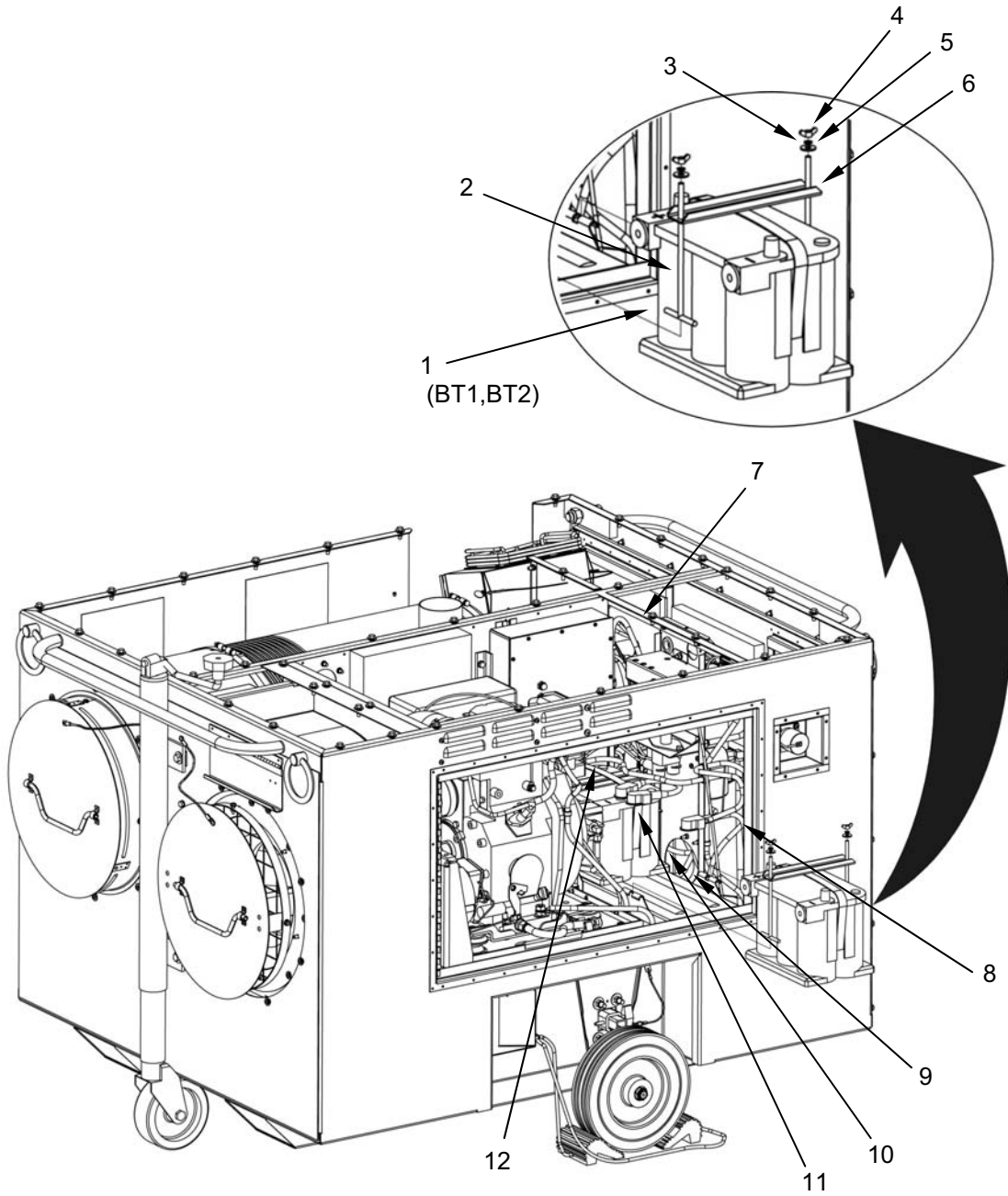

Figure 15. Battery, Storage

(1)	(2)	(3)	(4)	(5)	(6)	(7)
ITEM NO	SMR CODE	NATIONAL STOCK NUMBER	CAGEC	PART NUMBER	DESCRIPTION AND USABLE ON CODE (UOC)	QTY
					GROUP 06	
					FIG. 15 BATTERY, STORAGE	
1	PCOZZ	6140-01-475-9361	0UJ55	75/35	BATTERY, STORAGE.....	2
2	XDOZZ		92878	40610	RETAINER, BATTERY	4
3	PAOZZ	5310-00-582-5965	99539	CMB21389	WASHER, LOCK	4
4	PAOZZ	5310-01-384-2546	96906	MS51553-420	NUT, SELF-LOCKING, WING	4
5	PAOZZ	5310-01-274-3255	96906	MS27183-52	WASHER, FLAT	4
6	XDOZZ		92878	40611	RETAINER, BATTERY	2
7	XDOZZ		92878	40616	LEAD, STORAGE BATTERY	1
8	XDOZZ		92878	40632	LEAD, STORAGE BATTERY	1
9	XDOZZ		92878	40621	LEAD, STORAGE BATTERY	1
10	XDOZZ		92878	40622	LEAD, STORAGE BATTERY	1
11	XDOZZ		92878	40613	LEAD, STORAGE BATTERY	1
12	XDOZZ		92878	40630	LEAD, STORAGE BATTERY	1
					END OF FIGURE	

OPERATOR, FIELD AND SUSTAINMENT MAINTENANCE

LARGE CAPACITY FIELD HEATER (LCFH)

NATO SLAVE CONNECTOR
11674728

REPAIR PARTS LIST

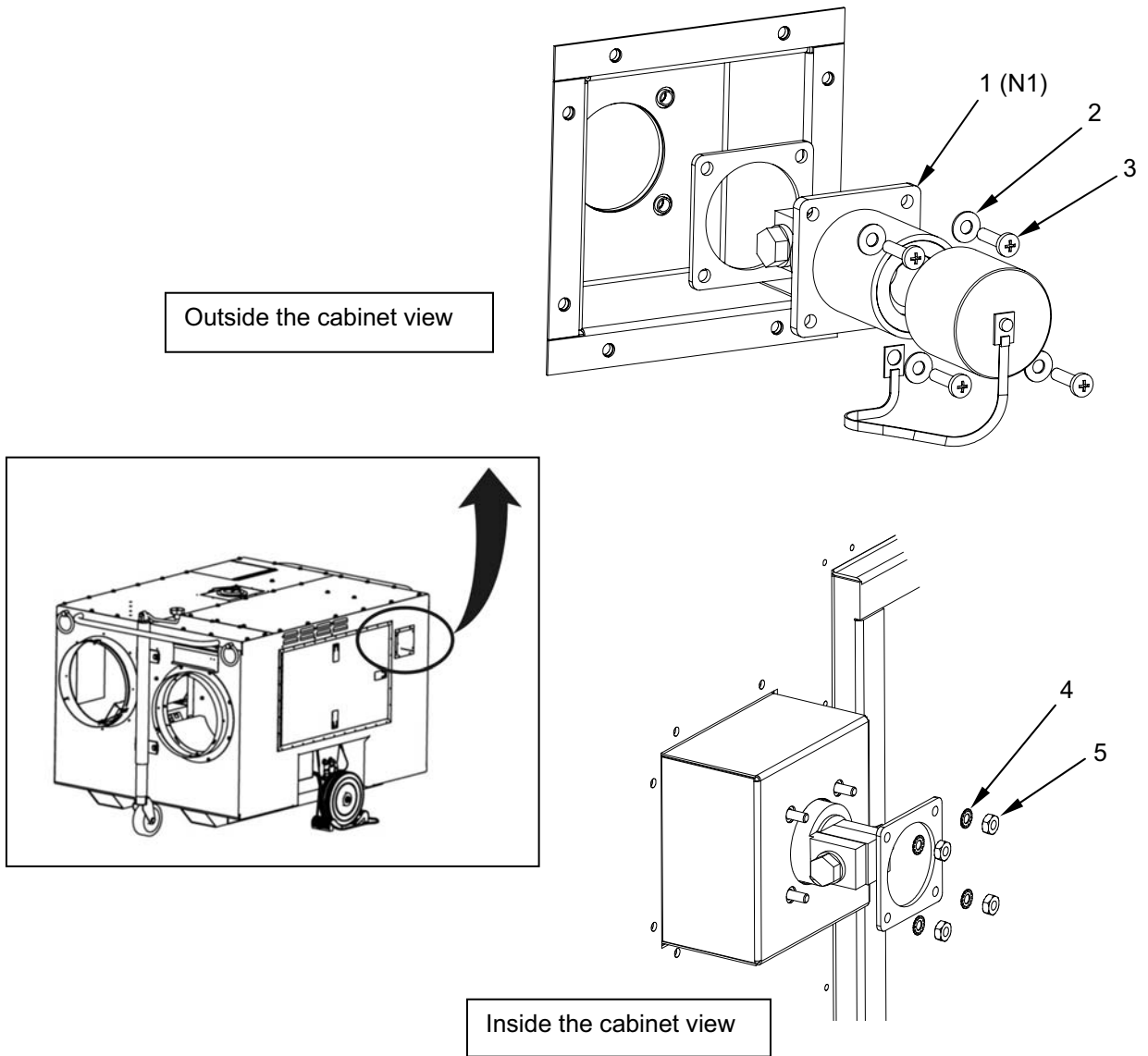

Figure 16. NATO Slave Connector

(1)	(2)	(3)	(4)	(5)	(6)	(7)
ITEM NO	SMR CODE	NATIONAL STOCK NUMBER	CAGEC	PART NUMBER	DESCRIPTION AND USABLE ON CODE (UOC)	QTY
					GROUP 07	
					FIG. 16 NATO SLAVE CONNECTOR	
1	PAOZZ	5935-01-097-9974	19207	11674728	NATO SLAVE CONNECTOR.....	1
2	PAOZZ	5310-00-727-8353	96906	MS27183-43	WASHER, FLAT.....	4
3	PAOZZ	5305-00-984-6212	80205	MS35206-265	SCREW, MACHINE.....	4
4	PAOZZ	5310-00-596-7691	96906	MS35335-32	WASHER, LOCK.....	4
5	PAOZZ	5310-00-934-9758	80205	MS35649-202	NUT, PLAIN, HEXAGON.....	4
					END OF FIGURE	

OPERATOR, FIELD AND SUSTAINMENT MAINTENANCE

LARGE CAPACITY FIELD HEATER (LCFH)

MAIN CONTROL BOX
40401

REPAIR PARTS LIST

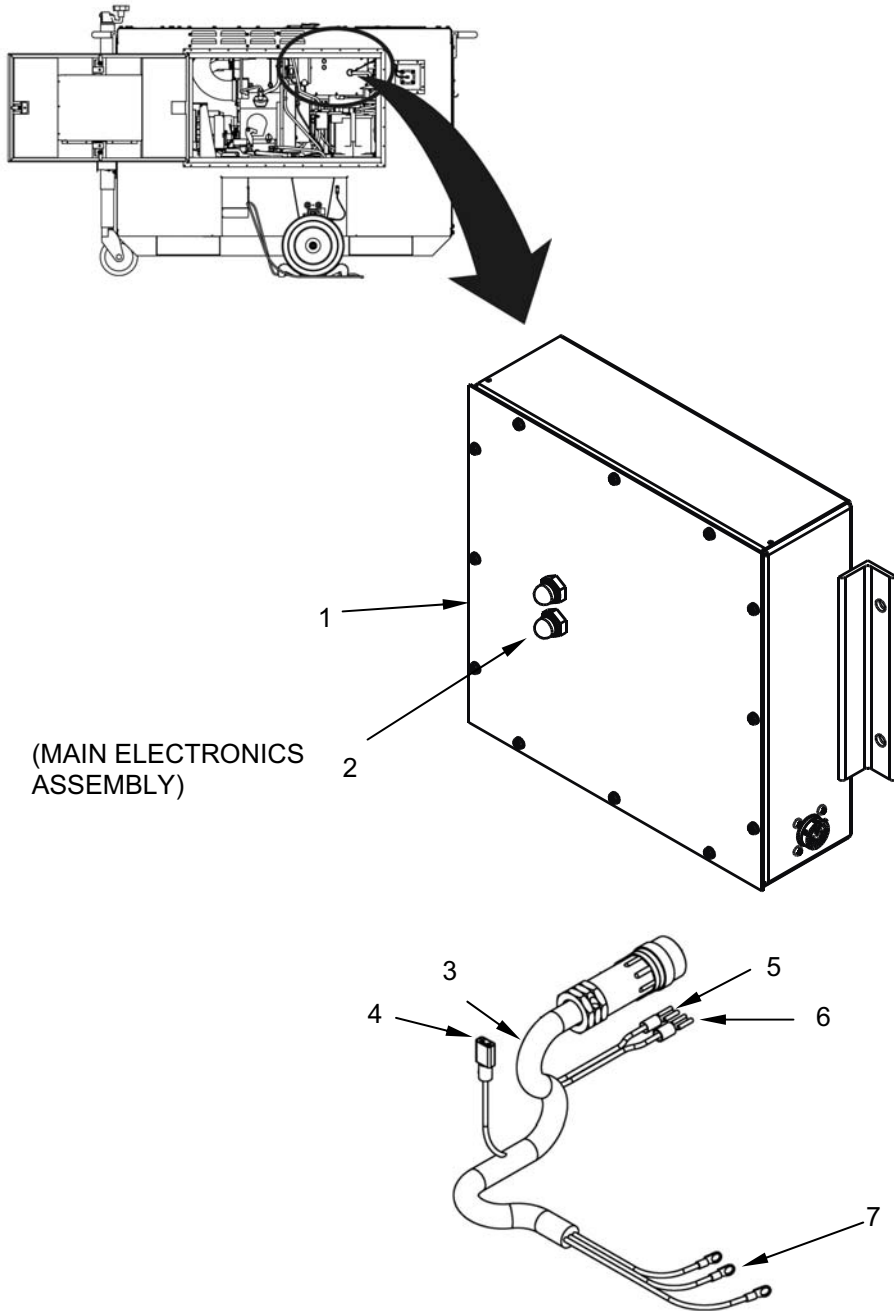

Figure 17. Main Control Box (Sheet 1 of 2).

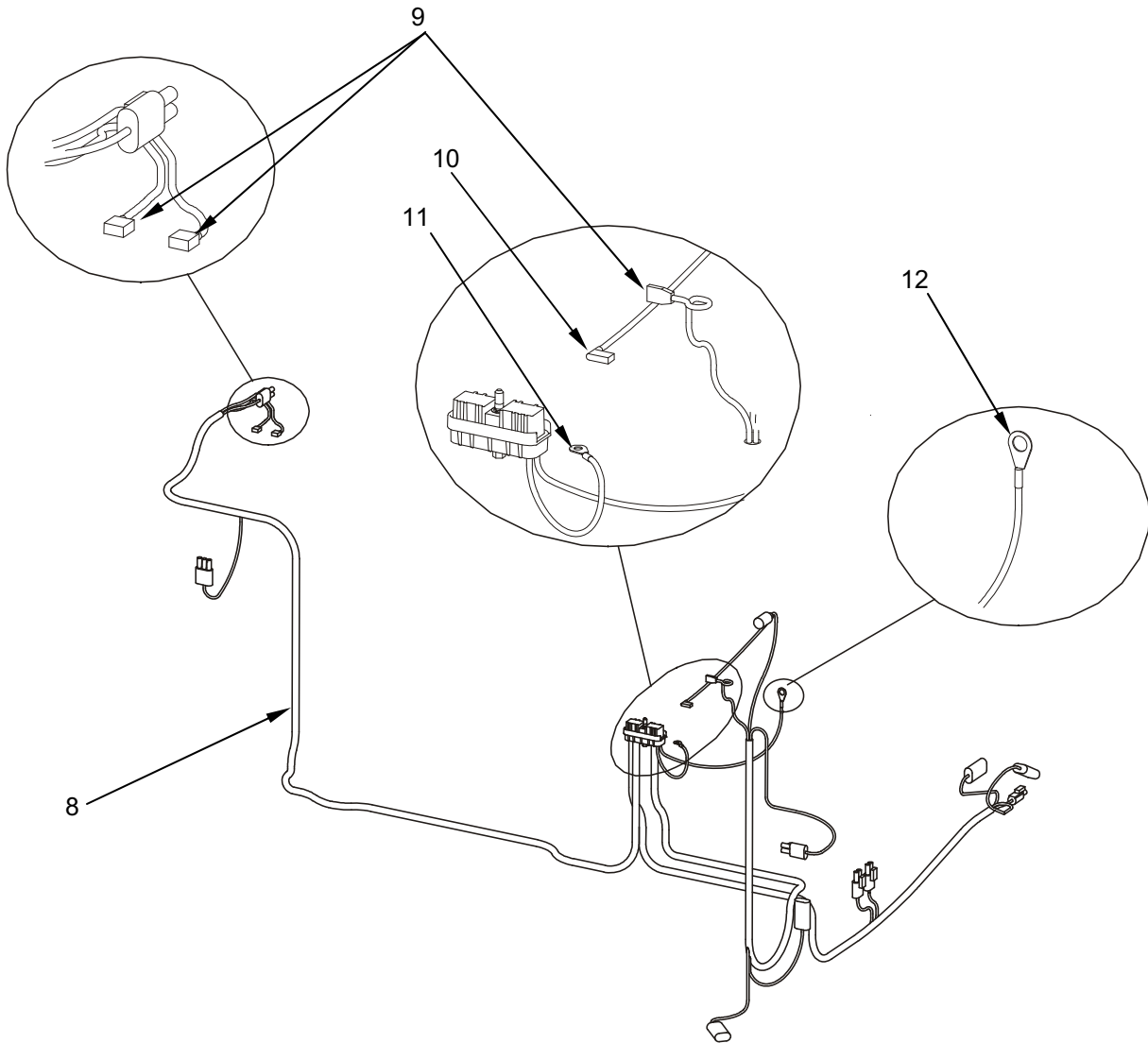

Figure 17. Main Control Box (Main Wiring Harness) (Sheet 2 of 2).

Change 1

0110 00-2

(1)	(2)	(3)	(4)	(5)	(6)	(7)
ITEM NO	SMR CODE	NATIONAL STOCK NUMBER	CAGEC	PART NUMBER	DESCRIPTION AND USABLE ON CODE (UOC)	QTY
					GROUP 08	
					FIG. 17 MAIN CONTROL BOX	
1	PAOKK	4520-01-539-7167	92878	40401	MAIN CONTROL BOX.....	1
2	PAOZZ	2530-01-461-7601	97539	NC3030 7/16-28	• BOOT, VEHICULAR COMPONENTS	2
3	XDOZZ		92878	40491	WIRING HARNESS	1
4	PAOZZ	5940-00-926-0085	98410	BB-2141	• TERMINAL, QUICK DISCONNECT	1
5	PAOZZ	5940-00-948-9686	97403	13216E6191-1	• TERMINAL, QUICK DISCONNECT	1
6	PAOZZ	5940-00-926-0085	06383	DVF14-250	• TERMINAL, QUICK DISCONNECT	1
7	PAOZZ	5940-00-534-0991	96906	MS35436-6	• TERMINAL, LUG	3
8	XDOZZ		92878	40494	MAIN WIRING HARNESS	1
9	PAOZZ	5940-01-184-7273	00779	2-520129-2	• TERMINAL, LUG	3
10	PAOZZ	5940-01-530-4760	58961	31535	• TERMINAL, QUICK DISCONNECT	1
11	PAOZZ	5940-00-143-4771	00779	32949	• TERMINAL, LUG	1
12	PAOZZ	5940-00-113-8184	81343	MS25036-150	• TERMINAL, LUG	1
					END OF FIGURE	

OPERATOR, FIELD AND SUSTAINMENT MAINTENANCE

LARGE CAPACITY FIELD HEATER (LCFH)

ASSEMBLY, OPERATOR CONTROL BOX
40405

REPAIR PARTS LIST

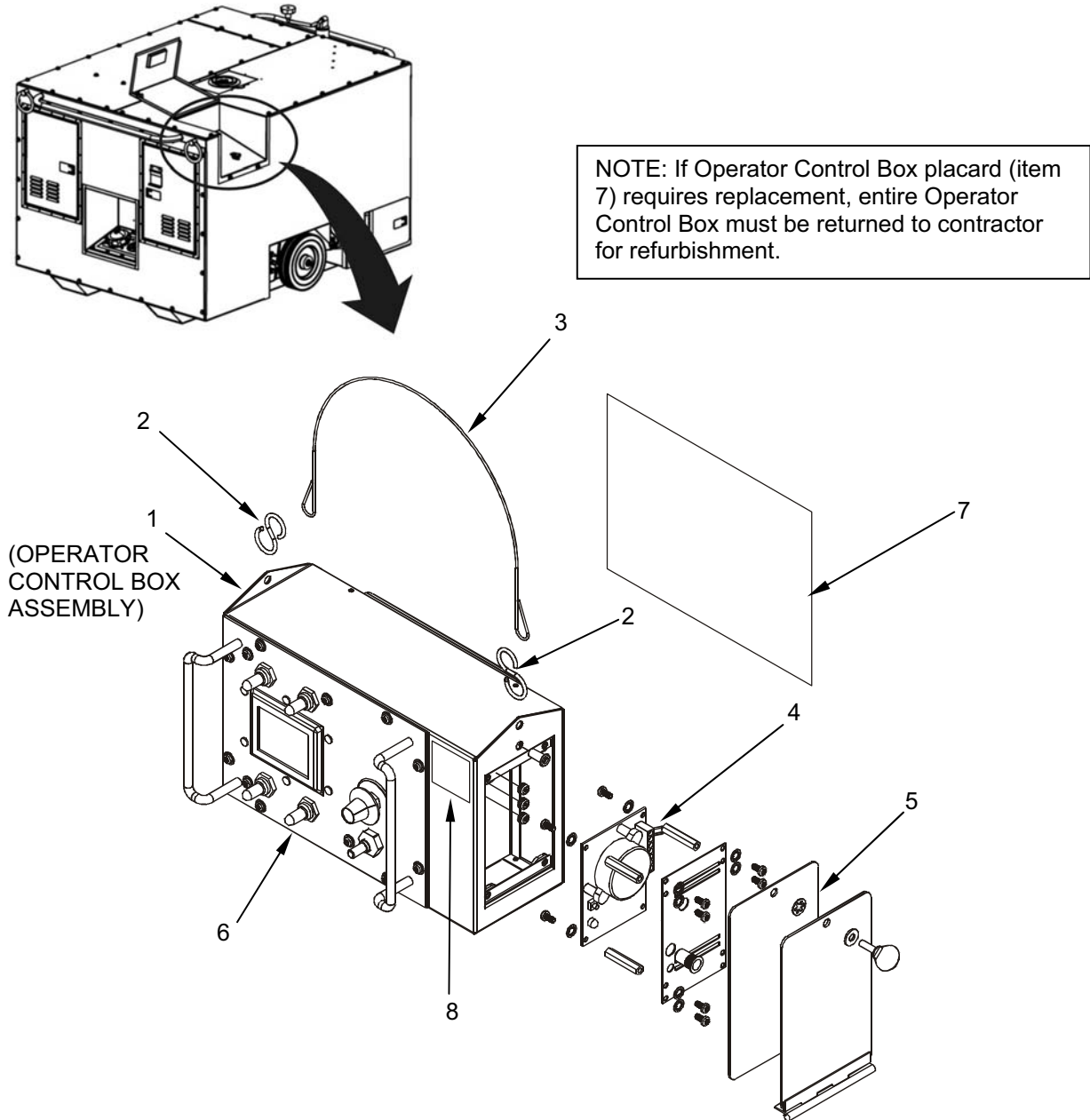

Figure 18. Assembly, Operator Control Box (Sheet 1 of 2).

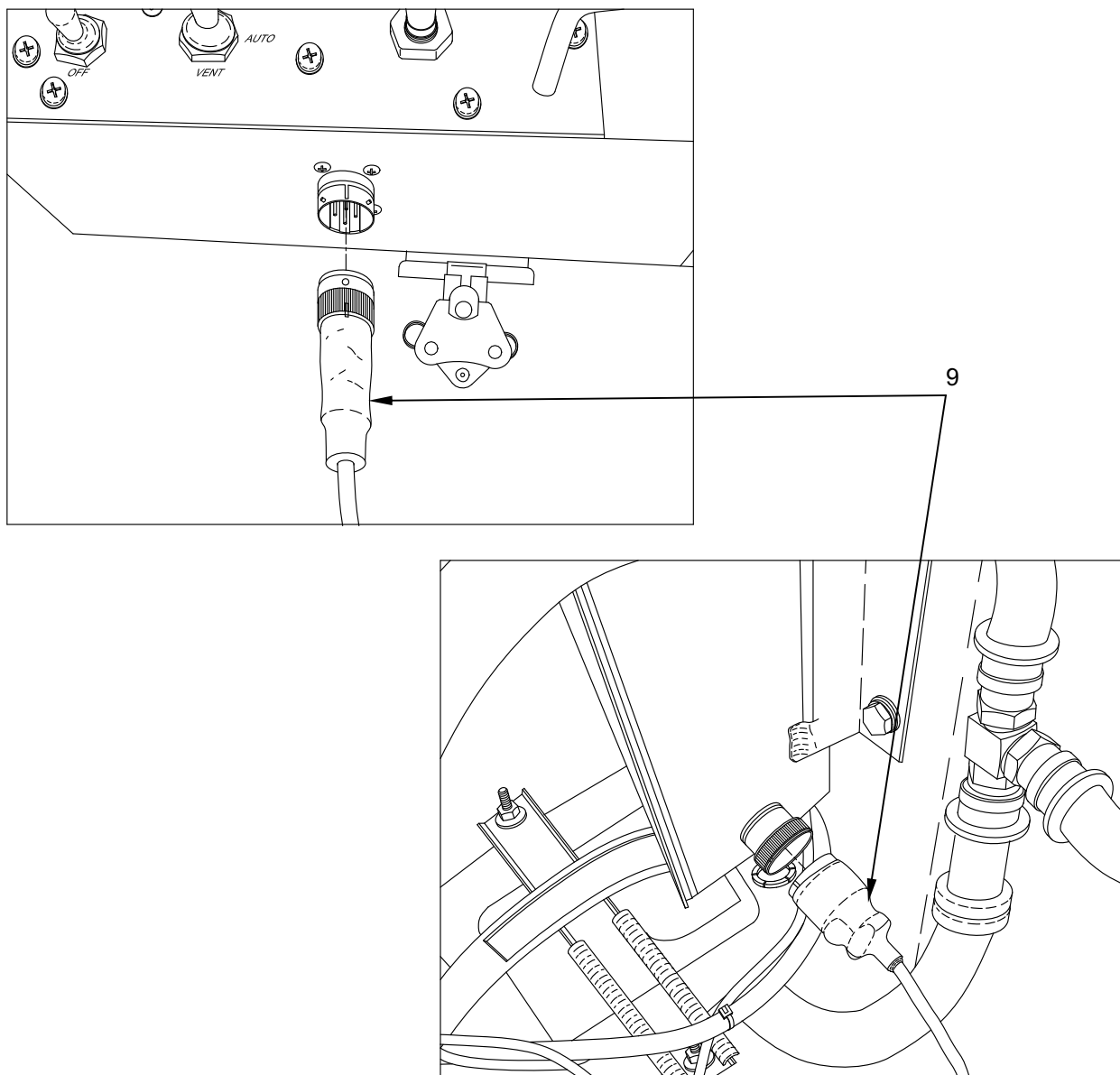

Figure 18. Control Cable (Sheet 2 of 2).

Change 1

0111 00-2

(1)	(2)	(3)	(4)	(5)	(6)	(7)
ITEM NO	SMR CODE	NATIONAL STOCK NUMBER	CAGEC	PART NUMBER	DESCRIPTION AND USABLE ON CODE (UOC)	QTY
					GROUP 09	
					FIG. 18 ASSEMBLY, OPERATOR CONTROL BOX	
1	PAOOO	4520-01-539-7164	92878	40405	ASSEMBLY, OPERATOR CONTROL BOX.....	1
2	PAOZZ	4030-00-780-9350	96906	MS87006-13	• HOOK, CHAIN-S	2
3	XDOZZ		92878	40430	• WIRE ROPE ASSEMBLY, SINGLE LEG ..	1
4	PCOZZ	6665-01-539-7171	92878	40480	• INDICATOR, CARBON MONOXIDE	1
5	XDOZZ		92878	40458	• GASKET	1
6	PAOZZ	5930-01-486-4755	097M6	SSB1	• BOOT, DUST AND MOISTURE SEAL	1
7	XDKZZ		92878	40051-02	• PLACARD, OPERATING PROCEDURES AND FAULT CODES.....	1
8	XDOZZ		92878	40841	• LABEL, CARBON MONOXIDE DETECTOR.....	1
9	PAOZZ	6150-01-539-7170	92878	40490	CABLE, POWER, ELECTRICAL	1
					END OF FIGURE	

OPERATOR, FIELD AND SUSTAINMENT MAINTENANCE

LARGE CAPACITY FIELD HEATER (LCFH)

AIR DUCT, INSULATED, 16 INCH DIA X 15 FEET LONG
40700

REPAIR PARTS LIST

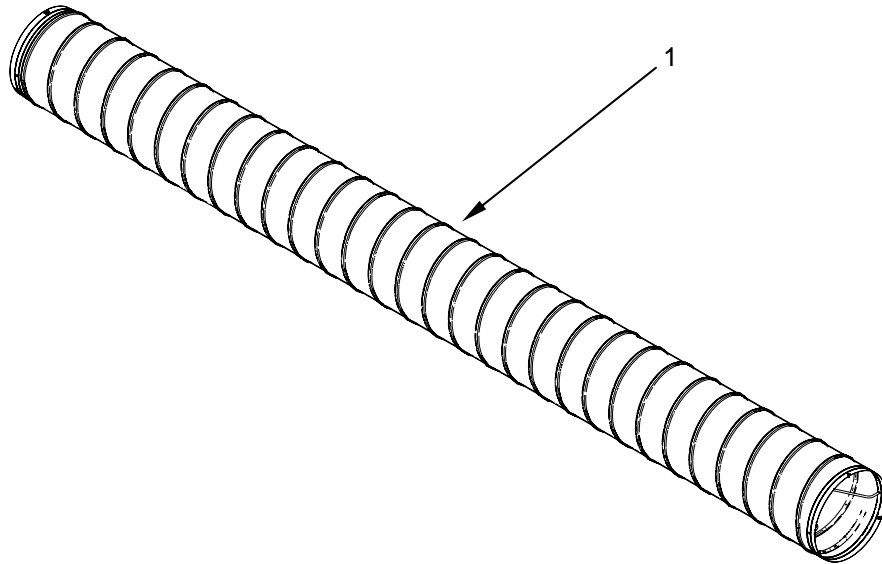

Figure 19. Air Duct, Insulated, 16 Inch DIA x 15 Feet Long.

(1)	(2)	(3)	(4)	(5)	(6)	(7)
ITEM NO	SMR CODE	NATIONAL STOCK NUMBER	CAGEC	PART NUMBER	DESCRIPTION AND USABLE ON CODE (UOC)	QTY
1	PAOZZ	4720-01-539-7168	92878	40700	GROUP 10 FIG. 19 AIR DUCT, INSULATED, 16 INCH DIA X 15 FEET LONG AIR DUCT, INSULATED, 16 INCH DIA X 15 FEET LONG 2 END OF FIGURE	

OPERATOR, FIELD AND SUSTAINMENT MAINTENANCE

LARGE CAPACITY FIELD HEATER (LCFH)

DUCT COVERS

40514

REPAIR PARTS LIST

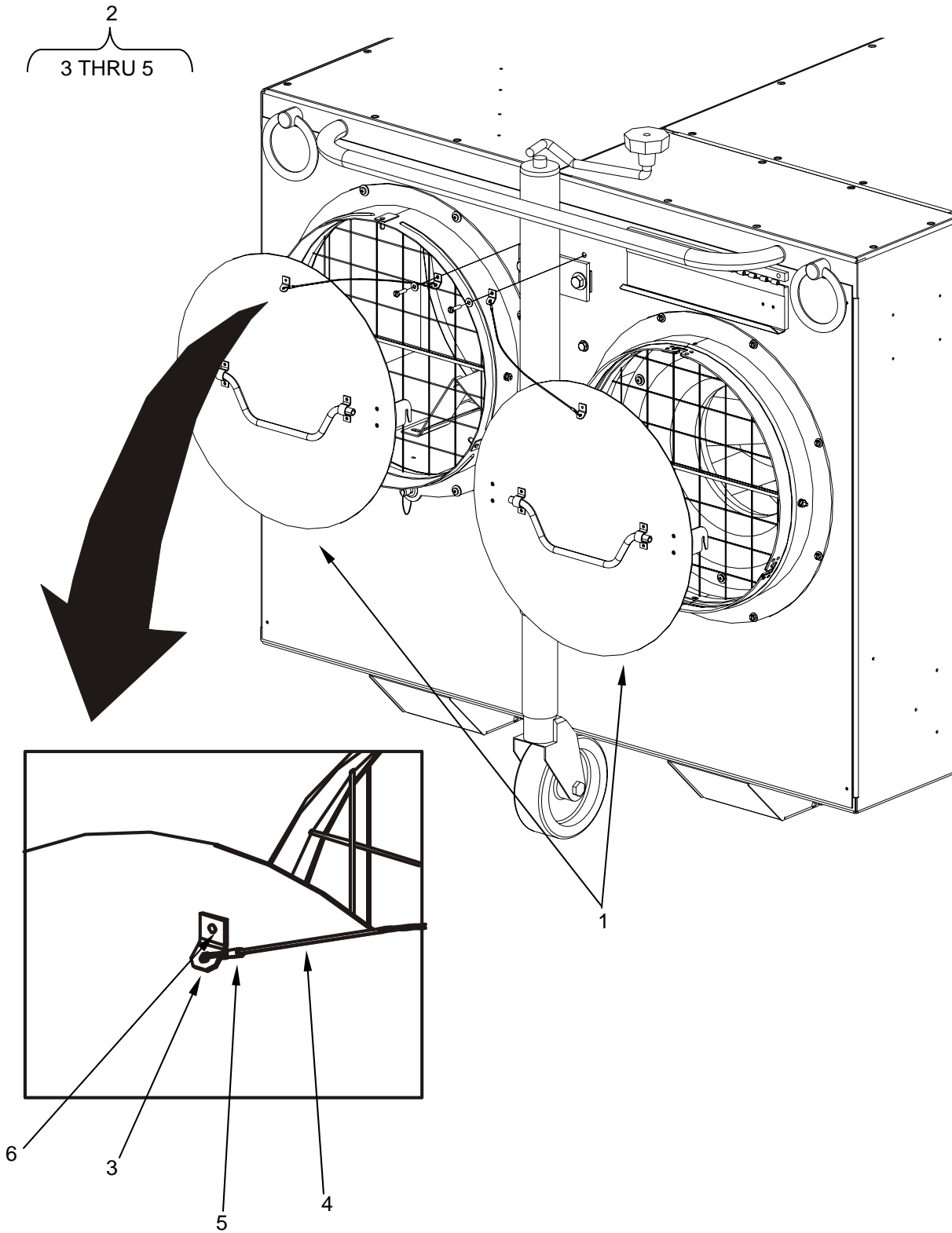

Figure 20. Duct Covers

0113 00-2

(1)	(2)	(3)	(4)	(5)	(6)	(7)
ITEM NO	SMR CODE	NATIONAL STOCK NUMBER	CAGEC	PART NUMBER	DESCRIPTION AND USABLE ON CODE (UOC)	QTY
					GROUP 11	
					FIG. 20 DUCT COVERS	
1	XDOZZ		92878	40514	DUCT COVER.....	2
2	XDOOO		92878	75263-100	• LANYARD ASSEMBLY, COVER.....	2
3	XAOZZ		92878	75262-1	• • BRACKET, LANYARD	2
4	MOOZZ		39428	8923T32	• • CABLE (MAKE FROM BULK SUPPLY NSN 4010-00-575-6233)	2
5	PAOZZ	4030-00-145-5721	96906	MS51844-64	• • SLEEVE, SWAGING, WIRE ROPE.....	4
6	PAOZZ	5320-00-956-7355	81349	M24243/6A604 H	• • RIVET, BLIND	2
					END OF FIGURE	

OPERATOR, FIELD AND SUSTAINMENT MAINTENANCE

LARGE CAPACITY FIELD HEATER (LCFH)

BULK ITEMS

REPAIR PARTS LIST

(1)	(2)	(3)	(4)	(5)	(6)	(7)
ITEM NO	SMR CODE	NATIONAL STOCK NUMBER	CAGEC	PART NUMBER	DESCRIPTION AND USABLE ON CODE (UOC)	QTY
					GROUP 99 BULK ITEMS	
					FIG. 99	
1	PAOZZ	4720-00-913-5910	01276	2565-4	HOSE, NONMETALLIC (1/4 IN ID).	AR
2	PAOZZ	4720-00-273-9514	19207	839981	HOSE, NONMETALLIC (3/8 IN ID)	AR
3	PAOZZ	4720-01-499-3769	81343	J30R7-5	HOSE, NONMETALLIC (5/16 IN ID).....	AR
4	XDOZZ		0E328	8451A53	MOLDING, PLASTIC	AR
5	PAOZZ	4010-00-575-6233	39428	8923T32	ROPE, WIRE	AR
					END OF FIGURE	

**OPERATOR, FIELD AND SUSTAINMENT MAINTENANCE
LARGE CAPACITY FIELD HEATER (LCFH)
NATIONAL STOCK NUMBER INDEX**

STOCK NUMBER	FIG	ITEM	STOCK NUMBER	FIG	ITEM
4730-00-003-5919	5	4		8	80
4370-00-014-1539	12	10	4730-00-555-1152	4	5
5310-00-014-5850	6	4		4	10
	7	13		4	41
	8	58		4	43
	10	4		4	44
	14	12		4	46
5310-00-045-3296	6	5		4	48
	7	14		4	51
5306-00-050-1238	8	52		4	55
5340-00-057-3043	8	5		4	57
5310-00-061-7325	7	6		8	18
5310-00-062-4954	8	67		8	45
5305-00-068-0501	8	66	5310-00-559-0070	5	10
	8	75	4730-00-566-1296	12	7
5305-00-068-0502	2	22	4010-00-575-6233	20	5
	4	20	5310-00-582-5677	12	12
	8	33		13	8
5305-00-068-0511	2	3	5310-00-582-5965	2	23
4730-00-073-2151	6	19		8	37
5310-00-081-4219	8	54		11	6
5310-00-081-8087	4	30		15	3
	14	10	4730-00-588-2614	4	52
5310-00-087-4652	2	5		8	41
5940-00-113-8184	17	12	4730-00-595-0251	5	12
5940-00-114-1300	4	60	5310-00-596-7691	4	31
5940-00-143-4771	17	11		7	3
4030-00-145-5721	19	5		8	57
5305-00-179-8946	7	16		14	13
4730-00-202-6491	4	19		16	4
	6	12	5340-00-598-0597	4	16
5310-00-209-0786	4	27		8	47
5305-00-225-3843	11	8	5310-00-637-9221	7	2
5306-00-225-8499	8	70	5310-00-637-9541	4	35
5305-00-226-7768	8	69		8	13
4730-00-235-1482	4	7		8	49
4730-00-254-6211	4	2	4730-00-647-3207	12	4
	5	7	5310-00-685-3228	14	19
	8	21	5305-00-702-4523	13	6
4730-00-254-6225	6	11	4730-00-723-5549	4	15
	8	26		8	27
4730-00-263-2733	5	14	5305-00-724-5851	12	17
4720-00-273-9514	20	2	5310-00-727-8353	16	2
4730-00-277-9615	8	25	5310-00-732-0558	4	34
4730-00-289-2368	5	15	5310-00-761-6882	4	26
4730-00-350-9619	14	2		8	35
4730-00-366-3011	4	11		8	81
5940-00-378-7225	4	67	5305-00-765-4257	12	18
5310-00-407-9566	8	7	4030-00-780-9350	18	2
5305-00-470-3321	6	3	5340-00-809-1490	4	21
5940-00-534-0991	17	7	5310-00-809-4058	4	28
4730-00-541-8100	5	13		7	9
5310-00-543-2410	8	34		8	42

STOCK NUMBER	FIG	ITEM	STOCK NUMBER	FIG	ITEM
	8	79	6680-01-220-2936	6	8
	11	7	4730-01-231-2751	8	40
5310-00-809-4061	2	4	5940-01-234-7272	14	5
	4	36	5305-01-255-6548	9	22
	8	14	5310-01-274-3255	2	24
5310-00-809-8544	2	15		15	5
5310-00-829-4061	14	18	5977-01-280-0378	12	19
5310-00-855-1102	12	14	5306-01-303-2815	7	10
	13	10	2940-01-310-4495	9	19
5310-00-880-7744	8	19	4730-01-322-4956	9	71
	8	60	5360-01-322-8623	9	91
5310-00-883-9417	12	13	5360-01-322-8631	9	134
	13	9	5310-01-322-8747	9	17
5305-00-889-3002	5	9	3110-01-322-9532	9	31
4730-00-894-5574	6	14	4320-01-323-0298	9	125
4730-00-900-3296	5	11	2815-01-323-0352	9	49
4720-00-913-5910	6	16	2815-01-323-0353	9	51
	20	1	5331-01-323-2728	9	59
5940-00-926-0085	17	4		9	163
	17	6	2940-01-323-3289	9	14
5310-00-934-9751	7	17	3040-01-323-3294	9	90
5310-00-934-9758	7	11	5306-01-323-5440	9	93
	16	5	5307-01-323-5504	9	2
5940-00-948-9686	17	5	5307-01-323-5505	9	5
5320-00-956-7355	19	6	5342-01-323-7866	9	27
5305-00-984-4984	2	14	5340-01-323-7879	9	18
	14	11	2815-01-324-6801	9	102
5305-00-984-4993	4	23	5330-01-324-8254	9	55
5305-00-984-6210	10	3		9	72
	14	14	5331-01-324-8279	9	124
5305-00-984-6212	4	18		9	161
	16	3	3110-01-324-8817	9	78
5305-00-988-1727	8	82	5305-01-325-8387	4	8
5305-00-989-7435	4	32	5330-01-326-2669	9	70
	7	4		9	164
	8	56	5330-01-326-4780	9	166
4730-00-995-1568	12	6	5331-01-326-8017	9	148
5320-01-023-2529	2	33	5310-01-327-0778	9	16
	2	37	5330-01-328-4171	9	79
	2	39		9	162
	2	41	6680-01-330-0694	13	2
	2	44	5330-01-330-9564	9	30
2910-01-025-6853	4	13	2815-01-353-7523	9	147
6685-01-048-4144	11	9	5310-01-384-2546	15	4
4730-01-058-9758	8	2	5305-01-388-6229	9	149
5975-01-092-8655	12	15	5306-01-388-7402	9	122
5935-01-097-9974	1	5	5310-01-388-8826	9	77
	16	1		9	101
5310-01-137-4830	8	12		9	8
5940-01-139-0853	8	78	3010-01-389-9003	9	143
5340-01-153-0578	8	59	2940-01-389-9942	9	15
4730-01-157-5156	8	29	5310-01-398-0737	9	47
4730-01-158-6196	13	3	5340-01-415-3789	9	80
5945-01-170-6666	4	62	5342-01-415-3792	9	58
5320-01-172-5602	2	35	5330-01-415-3802	9	144
5940-01-184-7273	17	9	5365-01-415-6744	9	75
5935-01-214-4163	14	6	2815-01-416-3333	9	112

STOCK NUMBER	FIG	ITEM	STOCK NUMBER	FIG	ITEM
	9	118	5310-01-477-0592	9	61
5365-01-419-5477	9	7	5310-01-477-0596	9	60
4730-01-421-9277	12	2	5360-01-477-0601	9	142
4730-01-424-5432	8	3	5360-01-477-0602	9	98
4520-01-424-6353	9	10	5310-01-477-0603	9	20
5340-01-430-4761	9	141	5310-01-477-0606	9	21
5310-01-431-4064	9	100	5310-01-477-0607	9	12
5310-01-431-4066	9	129	5305-01-477-3508	9	13
5310-01-431-4070	9	46	5310-01-477-3930	9	85
5306-01-431-7459	9	138	5307-01-477-4022	9	64
5306-01-431-7460	9	151	5307-01-477-4029	9	63
5306-01-431-7461	9	56	5330-01-477-4043	9	9
5315-01-431-8229	9	92	5340-01-479-5255	2	27
	9	150	5315-01-481-2030	2	9
5315-01-431-8230	9	109	5930-01-485-9200	4	37
5305-01-431-9398	9	139	5365-01-486-3251	9	104
5315-01-432-1210	9	44	5330-01-486-4449	9	105
5340-01-433-5456	9	136		9	165
5340-01-433-5457	9	123	5930-01-486-4755	18	6
5340-01-433-5458	9	132	5940-01-486-5422	4	65
5340-01-433-5460	9	24	4520-01-492-9125	14	3
5340-01-449-3915	9	25	4520-01-493-2780	4	22
2920-01-452-8409	9	153	4520-01-493-2785	6	20
5305-01-454-7982	8	48	4720-01-499-3769	20	3
4320-01-457-0232	9	131	2530-01-503-5000	14	4
2530-01-461-7601	17	2	5940-01-513-1400	4	64
3110-01-465-3473	9	87	2815-01-524-7056	9	69
3110-01-465-3598	9	81	5330-01-526-5104	9	6
2990-01-465-5995	9	127		9	160
2815-01-465-6393	9	36	4810-01-526-5186	9	89
2815-01-465-6703	9	45	2815-01-526-5197	9	110
2815-01-465-6745	9	96	5340-01-526-5277	9	28
5310-01-465-7108	8	6	5330-01-526-5339	9	94
2805-01-465-7528	9	37		9	167
2910-01-465-8277	9	33	5365-01-526-7332	9	88
2815-01-465-9578	9	48	5306-01-526-7343	9	137
2815-01-465-9616	9	50	4820-01-526-7409	9	82
5305-01-465-9934	9	43	5306-01-526-7950	9	140
5330-01-466-0701	9	3	5310-01-526-8383	9	133
	9	159	5315-01-526-8491	9	68
5331-01-466-0712	9	67	2910-01-530-0749	9	121
	9	157	2910-01-530-0758	9	120
5330-01-466-0713	9	84	3110-01-530-1167	9	38
	9	155	2815-01-530-1252	9	108
5310-01-466-4888	9	53	2815-01-530-1259	9	106
5340-01-466-7801	8	84	2815-01-530-1293	9	107
5340-01-467-7561	2	29	2815-01-530-1527	9	34
5340-01-470-3631	9	97	5940-01-530-4760	4	59
5306-01-471-6051	9	54		17	10
6140-01-475-9361	1	6	5330-01-530-6327	9	65
6140-01-475-9361	15	1		9	156
4820-01-475-9972	8	22	5330-01-530-6424	9	154
4820-01-477-0277	9	99	4730-01-534-4664	14	15
	9	158	5305-12-156-4863	8	74
4820-01-477-0283	9	95	5307-14-469-7400	9	73
2815-01-477-0536	9	35	5305-14-469-7436	9	83
5310-01-477-0582	9	62	5307-14-469-7440	9	74

STOCK NUMBER	FIG	ITEM
5305-14-469-8502	9	115
5340-98-205-1855	9	66
5306-98-205-1856	9	76
5315-98-205-1859	9	57

**OPERATOR, FIELD AND SUSTAINMENT MAINTENANCE
LARGE CAPACITY FIELD HEATER (LCFH)
PART NUMBER INDEX**

PART NUMBER	FIG.	ITEM	PART NUMBER	FIG.	ITEM
0 332 209 203	4	62	114350-01250	9	61
0112877	12	10	114350-01380	9	67
10006B-106	8	40		9	157
101158-11180	9	97	114350-01412	9	84
102100-67080	9	139		9	155
103338-32570	9	124	114350-01700	9	66
	9	161	114350-02100	9	87
103854-01221	9	47	114350-02113	9	81
105010-11490	9	95	114350-02200	9	87
10512	9	22	114350-02210	9	87
105225-01240	9	60	114350-11120	9	98
105425-01690	9	71	114350-11340	9	99
106534	6	17		9	158
110380A	2	4	114350-12011	9	4
114250-01800	9	75	114350-12202	9	3
114250-01830	9	80		9	159
114250-01841	9	79	114350-14450	9	48
	9	162	114360-45101	9	29
114250-03591	9	90	114362-77990	9	153
114250-03640	9	91	114368-01453	9	86
114250-11240	9	112	114368-13500	9	23
	9	118	114370-45351	9	26
114250-11600	9	100	114380-23100	9	41
114250-11901	9	102	114399-22300	9	36
114250-12211	9	6	114699-01760	9	58
	9	160	114770-61190	9	146
114250-12520	9	18	114770-61520	9	145
114250-12530	9	15	114770-61600	9	144
114250-12550	9	16	114770-61610	9	143
114250-12560	9	17	114771-11250	9	110
114250-12581	9	19	114771-11260	9	116
114250-13201	9	166	114771-11310	9	94
114250-14200	9	49		9	167
114250-21550	9	46	114771-11461	9	105
114250-32010	9	125		9	165
114250-32070	9	123	114771-11470	9	104
114250-35110	9	147	114771-11650	9	117
114250-35150	9	85	114771-11660	9	113
114250-45301	9	28	114771-11950	9	89
114250-45310	9	27	114771-14260	9	51
114250-45330	9	30	114870-66010	9	142
114250-66050	9	141	114871-01330	9	65
114250-66200	9	134	114871-01330	9	156
114250-66440	9	138	114871-11020	9	108
114250-76600	9	24	114871-11100	9	106
114250-76610	9	25	114871-11110	9	107
114270-01600	9	57	114871-59802	9	119
114299-02030	9	82	114871-66550	9	130
114299-66100	9	135	114881-21590	9	45
114350-01200	9	63	11674728	1	5
114350-01210	9	64		16	1
114350-01220	9	62	118200-23200	9	42

PART NUMBER	FIG.	ITEM	PART NUMBER	FIG.	ITEM
12010973	14	6		9	149
12089040	14	5	26106-060452	9	115
12089679	14	4	26106-060552	9	93
12408	12	15	26106-080122	9	83
129100-77510	9	9	26106-080352	9	56
129400-77501	9	10	26106-080552	9	13
13216E6191-1	17	5	26106-100122	9	76
13300-100	12	19	26106-100302	9	151
135210-61090	9	132	26117-040088	9	140
160110-02220	9	55	26226-060142	9	5
	9	72	26226-060182	9	73
160725-78350	9	136	26226-060222	9	74
160842-21150	9	43	26226-060552	9	2
160842-21250	9	54	26226-060602	9	103
160842-21260	9	53	26347-060002	9	133
1723A22	8	59	26366	9	77
183375-77560	9	7		9	101
183375-77570	9	11	26366-060002	9	8
2000-2-4B	5	11	26476-060142	9	122
202498	6	6	26696-100002	9	129
210P-2	14	2	26716-060002	9	21
2-2 140237C	12	7	26716-080002	9	152
2203B510	4	5	26856-060002	9	114
	4	10	27310-060001	9	96
	4	41	2BE10YDN TABLE 7-3 REF 26	9	109
	4	43	2BE10YDN TABLE 7-3 REF 37	9	92
	4	44		9	150
	4	46	30682-6-6B	4	52
	4	48		8	41
	4	51	31535	4	59
	4	55		17	10
	4	57	3220X6X4	4	19
	8	18		6	12
	8	45	32949	17	11
22190-160002	9	70	3400X4X2	5	15
	9	164	3655	5	7
22217-060000	9	20	40000	1	1
22217-080000	9	12	40021	2	40
22242-000120	9	111	40022	2	34
22252-000210	9	33	40031	2	38
22312-040080	9	68	40035	1	16
22319	5	13		13	1
22322-030200	9	128	40041	2	32
224-4	8	2	40050	1	11
22451-060000	9	131		1	15
22512-040120	9	44		2	1
23876-010000	9	88		3	1
24101-062024	9	31	40051-01	2	36
24162-152112	9	78	40051-02	18	7
24311-000180	9	59	40052	2	43
	9	163	40100	1	8
24341-000224	9	148		8	1
249-F-4-6	4	7	40101	1	7
2-520129-2	17	9		9	1
2565-4	6	16	40102	8	61
	21	1	40103	8	68
26106-060142	9	137	40104	8	55

PART NUMBER	FIG.	ITEM	PART NUMBER	FIG.	ITEM
40105	8	73	40251	13	15
40106	8	63	40252	5	2
40107	8	39	40255	13	16
40111	8	32	40260	4	56
40112	8	31	40261	4	42
40114	2	31	40262	4	40
40115	8	30	40263	4	49
40119	8	11	40264	4	47
40132	8	71	40265	4	50
40138	8	85	40266	4	53
40139	1	22	40279	4	45
40139	8	77	40280	5	8
40146	8	50	40281	5	3
40147	8	72	40282	5	6
40161	8	65	40288	5	5
40162	7	5	40301	10	9
40163	8	64	40302-02	1	20
40165	8	62		12	1
40184	7	7	40303	1	10
40185	1	13		14	1
	7	1	40304	1	17
40186	7	8		11	1
40190	8	8	40310	10	6
40191	8	4	40311	13	12
40192	8	46	40320	10	2
40195	8	10	40321	10	5
40196	2	25	40325	10	8
	4	29	40331	14	7
	8	15	40332	14	8
	8	83	40333	14	16
40197	8	44	40350	13	7
40198	4	9	40352	12	5
40198	8	17	40355	13	11
40199	8	16	40356	13	5
40200	8	23	40357	12	16
40201	8	20	40362	13	4
40202	1	21	40363	13	13
	4	1	40370	1	3
40202-01	4	39		10	1
	4	58	40401	1	4
40207	6	10		17	1
40208	1	18	40404	4	61
	5	1	40405	1	2
40211	4	25		18	1
	8	28	40430	18	3
40213	8	38	40432	2	28
40220	4	24	40444	4	63
40221	4	3	40458	18	5
40223	4	14	40480	18	4
40224	4	4	40481	14	17
40232	4	54	40482	14	9
40240	6	2	40484	10	7
40243	12	3	40489	2	13
40245	12	9	40490	18	9
40247	12	8	40491	17	3
40249	12	11	40494	17	8
40250	13	14	40501	2	17

PART NUMBER	FIG.	ITEM	PART NUMBER	FIG.	ITEM
40502	2	6		8	53
40505	2	12	5321K14	8	3
40507	2	16	5914	14	3
40508	1	19	60384	4	22
	6	1	6174	11	4
40510	1	12	62-40-151-3	2	27
	2	2	62471	4	37
40514	1	9	640907-1	4	65
	20	1	6536K18	6	14
40516	7	12	6781-S5.120-F5.7	6	8
40517	2	26	696363-1	4	66
40520	2	7	7113K24	4	64
40528	2	10	714250-12560	9	14
40530-01	3	7	714350-28520	9	32
40530-02	3	9	714350-61500	9	127
40530-03	3	3	714380-23600	9	38
40530-04	3	5	714380-23610	9	40
40531-01	3	12	714380-23620	9	39
40531-02	3	8	714380-23700	9	37
40531-03	3	4	714650-51100	9	121
40531-04	3	11	714770-61100	9	126
40531-05	3	10	714870-22500	9	35
40533-01	3	2	714871-01560	9	69
40533-02	3	6	714871-53100	9	120
40563	8	76	714871-92600	9	154
40566	2	30	714872-22720	9	34
40586	2	11	714876-21730	9	52
40610	15	2	714880-14580	9	50
40611	15	6	75/35	1	6
40613	15	11		15	1
40616	15	7	75005-100	2	21
40621	15	9	75011-100	2	20
40622	15	10	75012-100	2	19
40630	15	12	75056-100	2	18
40632	15	8	75086	11	5
40661	4	33	75088-100	11	2
40662	4	38	75116-100	6	7
40700	1	14	75150	11	3
	19	1	75237-100	6	9
40702	1	23	75259-1	7	15
	6	15	75262-1	20	3
40724	6	18	75263-100	20	2
40790	12	20	839981	21	2
40838	2	42	8451A53	21	4
40841	18	8	863-000553	2	9
430-010	8	12	8923T32	20	4
4-4010202B	6	11		21	5
	8	26	90675A011	4	17
4534K39	8	24	91280A330	8	43
45X4X4X4	8	29	91280A340	8	36
4797-5-4B	6	19	91280A524	8	6
49X4X4	4	11	91280A530	8	74
50385K31	14	15	91280A643	8	51
50785K253	4	6	94830A560	2	8
50785K274	6	13	A17004-2	8	25
5-13-5616	6	20	AC65-4-5	8	66
52161	8	9	AD42BS	2	35

PART NUMBER	FIG.	ITEM	PART NUMBER	FIG.	ITEM
AD44BS	2	33	MS27183-15	4	36
	2	37	MS27183-42	6	4
	2	39	MS27183-43	16	2
	2	41	MS27183-52	2	24
	2	44		15	5
AS21919DG8	4	16	MS27183-7	2	15
	8	47	MS35206-227	2	14
B1821BH025C100N	11	8	MS35206-227	14	11
B1821BH031F075N	8	52	MS35206-233	4	23
B1821BH038C125N	2	3	MS35206-242	5	9
BB-2141	17	4	MS35206-263	10	3
BF-580	4	13		14	14
C0502005700	5	12	MS35206-265	4	18
CBM21389	2	23		16	3
	8	37	MS35206-283	8	82
	11	6	MS35207	7	4
	15	3		8	56
DV14-250M	4	67	MS35207-264	4	32
DVF14-250	17	6	MS35307-306	13	6
F51N7582-616	2	5	MS35333-38	5	10
F98	2	22	MS35333-43	14	19
FB1301	4	12	MS35335-32	4	31
GW10U606SC2	7	2		8	57
H2525M	8	13		14	13
J30R7-5	21	3		16	4
J5124-2010202B	4	2	MS35335-33	4	27
	8	21	MS35338-158	12	13
J514	13	3		13	9
JD659	4	15	MS35338-40	8	34
	8	27		8	80
K3-1735-52	2	29	MS35338-43	6	5
M24243/6A604H	20	6		7	14
M551029-53	12	17	MS35338-45	8	7
MS15795-810	12	12	MS35338-46	4	35
	13	8		8	49
MS20659-105	4	60	MS35436-6	17	7
MS21044N06	4	30	MS35649-202	7	11
	14	10		16	5
MS21045-4	7	6	MS35649-2255	12	14
MS21045-5	8	60		13	10
MS21045-8	8	67	MS51504A3Z	12	2
MS21333-112	8	5	MS51504A4	12	4
MS21333-98	4	21	MS51508A4Z	12	6
MS21919-6	8	84	MS51553-420	15	4
MS25036-150	17	12	MS51819-3	5	4
MS27183	7	9	MS51844-64	20	5
	7	13	MS51849-66	7	16
	8	14	MS51849-74	6	3
	8	42	MS51959-43	12	18
	8	58	MS51967	8	35
	8	79	MS51967	8	81
	10	4	MS51967-2	4	26
	11	7	MS51967-5	8	19
	14	12	MS51967-8	4	34
	14	18	MS53650-302	7	17
MS27183-10	4	28	MS87006-13	18	2
MS27183-12	8	54	MS90725-13	7	10

PART NUMBER	FIG.	ITEM
MS90725-34	8	70
MS90725-5	8	75
MS90725-6	4	20
	8	33
MS90725-64	4	8
MS90726-115	8	69
MV602-2	8	22
NAF1058-10E	7	3
NAS1352-6-16P	8	48
NC3030 7/16-28	17	2
PD41024-19	13	2
RB25177	8	78
SSB1	18	6
TL20P-M 0-100BE NONMAG	11	9
VS2225P-2	5	14

**OPERATOR, FIELD AND SUSTAINMENT MAINTENANCE
LARGE CAPACITY FIELD HEATER (LCFH)
COMPONENTS OF END ITEM (COEI) AND BASIC ISSUE ITEMS (BII) LIST**

INTRODUCTION**Scope**

This section lists Components of End Item (COEI) and Basic Issue Items (BII) for the Large Capacity Field Heater (LCFH) to help you inventory items for safe and efficient operation of the equipment.

General

The COEI and BII information is divided into the following lists:

Components of End Item (COEI). This list is for information purposes only and is not authority to requisition replacements. These items are part of the LCFH. As part of the end item, these must be with the end item whenever it is issued or transferred between property accounts. Items of COEI are removed and separately packaged for transportation or shipment only when necessary. Illustrations are furnished to help you find and identify the items.

Basic Issue Items (BII). These essential items are required to place the LCFH in operation, operate it, and do emergency repairs. Although shipped separately packaged, BII must be with the LCFH during operation and when it is transferred between property accounts. Listing these items is your authority to request/requisition them for replacement based on authorization of the end item by the TOE/MTOE. Illustrations are furnished to help you find and identify the items.

Explanation of Columns in the COEI List and BII List.

Column 1, Illustration Number, gives you the number of the item illustrated.

Column 2, National Stock Number, identifies the stock number of the item to be used for requisitioning purposes.

Column 3, Description, Location, Part Number and CAGEC identifies the federal item name (in all capital letters) followed by a minimum description when needed. The last line below the description is the CAGEC (Commercial And Government Entity Code) (in parentheses) and the part number.

Column 4, Usable on Code, gives you a code if the item you need is not the same for different models of equipment. These codes are identified below.

<u>Code</u>	<u>Used On</u>
61S	LCFH

Column 5, U/M (Unit of Measure), indicates how the item is issued for the National Stock Number shown in Column 2.

Column 6, QTY. RQR, indicates the quantity required.

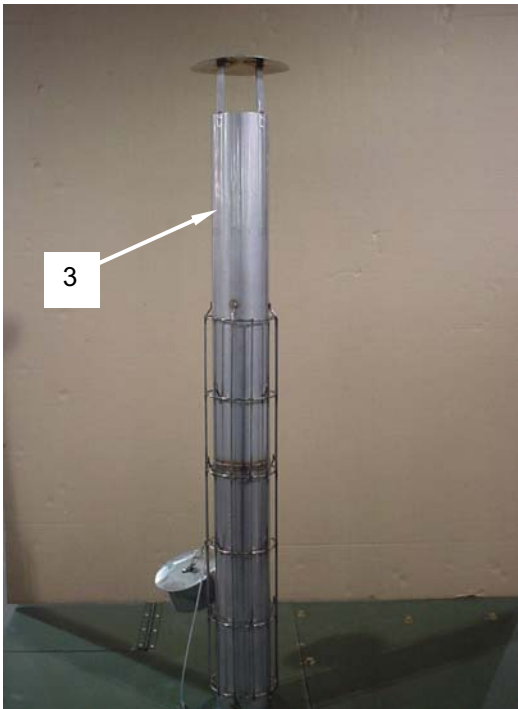
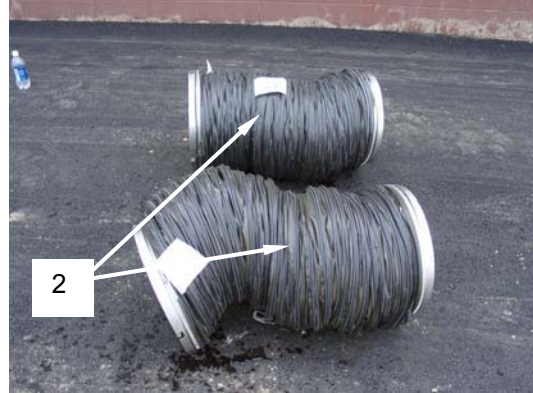

Section II. COMPONENTS OF END ITEM

(1) Illus Number	(2) National Stock Number	(3) Description (CAGEC) and Part Number	(4) U/I	(5) Qty Reqd
1	4520-01-539-7164	Assembly, Operator Control Box (92878) 40405	EA	1
2	4720-01-539-7168	Air Duct, Insulated, 16 IN x 15 FT (92878) 40700	EA	2
3	4520-01-539-7188	Pipe, Exhaust (92878) 40505	EA	1
4	4720-01-540-3595	Hose Assembly, Nonmetallic (92878) 40702	EA	1

TM 9-4520-272-14&P

TECHNICAL MANUAL

OPERATOR, FIELD AND SUSTAINMENT
MAINTENANCE MANUAL
INCLUDING REPAIR PARTS AND SPECIAL TOOLS LIST (RPSTL)

FOR

**LARGE CAPACITY FIELD HEATER (LCFH),
350,000 BTU, INCLUDING DIESEL ENGINE**

NSN 4520-01-500-1534 (EIC: VX8)



DISTRIBUTION STATEMENT A - Approved for public release; distribution is unlimited.

HEADQUARTERS, DEPARTMENT OF THE ARMY

1 JUNE 2006

Section III. BASIC ISSUE ITEMS

(1) Illus Number	(2) National Stock Number	(3) Description (CAGEC) and Part Number	(4) U/I	(5) Qty Reqd
1		Operator's, Field and Sustainment Maintenance Manual Including Repair Parts and Special Tools (RPSTL) for Large Capacity Field Heater (92878) 40000	EA	1

**OPERATOR, FIELD AND SUSTAINMENT MAINTENANCE
LARGE CAPACITY FIELD HEATER (LCFH)
ADDITIONAL AUTHORIZATION LIST (AAL)**

INTRODUCTION**Scope**

This Work Package lists additional items that are authorized for the support of the Large Capacity Field Heater (LCFH), and is provided to help you identify and request those items you need to support this equipment.

General

The identified items do not have to accompany the Large Capacity Field Heater (LCFH), and do not have to be turned in with it. These items are authorized to you by CTA, MTD, TDA, or JTA.

Explanation Of Columns In Additional Authorization List (AAL).

Column (1) - Item Number. Assigned to the given entry and referenced to in chapter narrative instructions for item identification (i.e., "Use dry cleaning solvent, Work Package 00XX 00").

Column (2) - National Stock Number. Indicates the NSN (National Stock Number) assigned to, and used for requisitioning of, an item.

Column (3) - CAGEC. The CAGEC (Commercial and Government Entity Code) is a five digit code listed in SB 708-42 which is used to identify the manufacturer, distributor, or Government agency, etc.

Column (4) - Part Number. Indicates the primary number used by the manufacturer (individual, company, firm, corporation, or Government activity), which control the design and characteristics of the item by means of its engineering drawings, specifications, standards, and inspection requirements to identify an item or range of items.

Column (5) - Description. Indicates the Federal item name and, if required, a minimum description to identify the items. Items that are included in kits and sets are listed below the name (of the kit or set) with the quantity of each item (in the kit or set) indicated in the *Quantity Incorporated in Unit* column.

Column (6) - UOC. If the item you need is not the same for different models of equipment, a UOC (Usable On Code) will appear in Column (5). UOC's used are (if applicable to this equipment):

Code	Usable On
61S	Large Capacity Field Heater

Column (7) - U/M. U/M (Unit of Measure) indicates the standard or basic quantity of the listed item as used in performing the actual maintenance function. This measure is expressed by a two character abbreviation (e.g., ea, in, pr, etc.). When the unit of measure differs from the unit of issue, the lowest unit of issue that will satisfy the required units of measure will be requisitioned.

Column (8) - Quantity Authorized. This column lists the authorized quantity which you may retain.

ADDITIONAL AUTHORIZED LIST ITEMS

(1) ITEM NUMBER	(2) NATIONAL STOCK NUMBER	(3) PART NUMBER	(4) CAGEC	(5) DESCRIPTION	(6) UOC	(7) U/M	(8) QUANTITY AUTHORIZED
1	5342-00-066-1235	13211E7541	06076	CONTAINER, ADAPTER, DRUM FILL	61S	EA	1
2		40791	92878	TOOL, ELECTRODE GAP AND NOZZLE ADJUSTMENT	61S	EA	1

**OPERATOR, FIELD AND SUSTAINMENT MAINTENANCE
LARGE CAPACITY FIELD HEATER (LCFH)
EXPENDABLE AND DURABLE ITEMS LIST**

EXPENDABLE AND DURABLE ITEMS LIST

This work package lists expendable and durable items that you will need to operate and maintain the Large Capacity Field Heater (LCFH). This listing is for information only and is not authority to requisition the listed items. These items are authorized to you by CTA 50-790, Expendable/Durable Items (except medical, Class V repair parts, and heraldic items), or CTA 8-100, Army Medical Department Expendable/Durable Items.

Explanation of Columns in the Expendable/Durable Items List

Column (1), Item Number. This number is assigned to the entry in the listing and is referenced in the narrative instructions to identify the item.

Column (2), Level. This column identifies the lowest level of maintenance that requires the item.

Column (3), National Stock Number. This is the national stock number assigned to the item which you can use to requisition it.

Column (4), Item Name, Description, Commercial and Government Entity Code (CAGEC), and Part Number. This provides the other information you need to identify the item.

Column (5), Unit of Measure (U/M). This code shows the physical measurement or Count of an item, such as gallon, dozen, gross, etc.

EXPENDABLE AND DURABLE ITEMS LIST

Table 1. Expendable and Durable Items List.

(1) ITEM NUMBER	(2) LEVEL	(3) NATIONAL STOCK NUMBER	(4) ITEM NAME, DESCRIPTION, PART NUMBER, (CAGEC)	(5) U/M
1	O	6810-00-286-5435	Alcohol, Isopropyl, TT-I-735 (81348)	GL
2	O		Sealant, thread, 5-13-5357, (81337)	OZ
3	O		Lubricant, silicone	OZ
4	C	7920-00-205-1711	Rags, wiping, clean, A-A-2522 (58536)	DZ
5	O	9905-00-537-8954	Tags, marking, MIL-T-12755 (81349)	BX
6	O		Tape, electrical	FT
7	O		Brush, Brass Wire	EA
8	C,O	7930-01-363-8631	Mat, Petroleum Absorbent, GOV106 (1JA49)	RL
9	O		Wrap, Tie	EA
10	C,O	7930-01-316-6008	Tray, Petroleum Absorbent, GOV103, (1JA49)	EA
11	O		Loctite 221 (50 ml)	EA
12	O		Loctite 648 (10 ml)	EA
13	O		Loctite Cleaner 7070 (0A083)	EA
14	O		Loctite Primer 7649 (0A083)	EA
15	O		Loctite Retaining Compound 641 (0A083)	EA
16	O		Technicoll 8058 (750g) (0A083)	EA
17	O		Technicoll 8367 (750g) (0A083)	EA
18	O		Loctite IS 407 (20g) (0A083)	EA
19	O		Silicon (30 ml)	EA
20	O		Grinding paste K 240 (80ml)	EA
21	O		High-temperature paste (1000g)	EA
22	O		High-temperature grease (100g)	EA
23	O		Silicon (100g)	EA
24	O	6850-00-274-5421	Solvent, Degreasing MIL-PRF-680	OZ
25	O		Oil, engine lubricating, Arctic, MIL-L-46167 (-50°C to 0°C)	QT
25	O		Oil, engine lubricating, 5W30 A.P.I. Engine Service Classification CC, CD, or CF (-30°C to 10°C)	QT
25	O		Oil, engine lubricating, 10W30 A.P.I. Engine Service Classification CC, CD, or CF (-20°C to 30°C)	QT
25	O		Oil, engine lubricating, 20W40 A.P.I. Engine Service Classification CC, CD, or CF (-10°C to 40°C)	QT
26	F		Shims, Timing	PK
27	O		Tape, Duct	RL
28	O		Rivet, Blind	EA
29	O		Bolt, M8 or M9 x 100mm, minimum length	EA
30	O		Pin, Cotter	EA

**OPERATOR, FIELD AND SUSTAINMENT MAINTENANCE
LARGE CAPACITY FIELD HEATER (LCFH)
ALPHABETICAL INDEX**

A

Additional Authorization List (AAL) 0116 00
 Assembly and Preparation for Use 0005 00

B

Before Operation PMCS 0005 00, 0010 00, 0018 00

C

Capabilities, Features, and Equipment Characteristics 0001 00
 Carbon Monoxide Detector, Deploying the 0005 00
 Checks and Services (PMCS):
 Operator Level 0010 00
 Unit Level 0018 00
 Chemical Decontamination Procedures 0006 00
 Cold, Operation in Extreme 0006 00
 Components of End Item and Basic Issue Items 0115 00
 Controls and Indicators 0004 00
 Corrosion Prevention and Control (CPC) 0001 00

D

Data, Equipment 0002 00
 Decals and Instruction Plates 0005 00
 Decontamination Procedures, Interim Nuclear, Biological, and Chemical (NBC) 0006 00
 Definitions, Leakage:
 for Operator PMCS 0009 00
 for Unit PMCS 0017 00
 Deploying Wheel Chocks 0005 00
 Description:
 and Location of Major Components 0002 00
 and Use of Operator's Controls and Indicators 0004 00
 Destruction of Army Materiel to Prevent Enemy Use 0001 00
 Direct Support Maintenance:
 Cylinder Block 0073 00
 Fuel Injection Pump 0074 00
 Governor Control 0075 00
 Introduction 0072 00
 Oil Pump 0076 00
 Rocker Arm Assembly 0077 00
 Dust or Sand, Operation in Extreme 0006 00

E

Equipment:
 Characteristics, Capabilities, and Features 0001 00
 Data 0002 00
 Improvement Recommendations (EIR), Reporting 0001 00
 Emergency Engine Shutdown Procedures 0006 01
 Exhaust Stack 0002 00
 Exhaust Stack, Deploying the 0005 00

Expendable and Durable Items List	0117 00
External Fuel Connector	0002 00, 0005 00
External Fuel Supply, Operating from	0005 00

F

Features, Equipment Characteristics, and Capabilities	0001 00
Flexible Ducts, Installing the	0001 00
Fresh Air Damper	0002 00, 0005 00
Fueling the LCFH	0005 00
Fueling the Internal Fuel Tank	0005 00

G

General Support Maintenance:	
Diesel Engine Piston and Connecting Rod	0087 00
Diesel Engine Balancer Shaft	0081 00
Diesel Engine Camshaft	0082 00
Diesel Engine Crankshaft	0083 00
Diesel Engine Cylinder Head	0084 00
Diesel Engine Fuel Injection Pump	0085 00
Diesel Engine Governor	0086 00
Introduction	0080 00
Main Wiring Harness Assembly	0088 00

H

Heater Controls and Indicators	0004 00
Heat Exchanger Assembly	0054 00
Humidity, Extreme, or Rain, Operation in	0006 00

I

Identification Plate	0005 00
Improvement Recommendations (EIR), Reporting Equipment	0001 00
Indicators and Controls	0004 00
Information Plate Locations	0005 00
Information Plates and Decals	0005 00
Initial Operator Control Box Settings	0005 00
Inlet and Outlet Duct Covers, Removing the	0005 00
Interim Nuclear, Biological, and Chemical (NBC) Decontamination Procedures	0006 00
Internal Fuel Tank	0002 00
Internal Fuel Tank, Fueling the	0005 00

L

LCFH Startup Codes	0005 00
LCFH Startup Time versus Outside Ambient Temperature	0005 00
Leakage Definitions:	
for Operator PMCS	0009 00
for Unit PMCS	0017 00
Location and Description of Major Components	0002 00
Locations, Information Plate	0005 00

M

Malfunction Symptom Index:	
Operator Level	0007 00

Unit Level	0015 00
Direct Support	0070 00
General Support.....	0078 00
Maintenance Allocation Chart Introduction	0090 00
Maintenance Allocation Chart	0091 00
Maintenance Checks and Services (PMCS):	
Operator Preventive	0010 00
Unit Preventive	0018 00
Maintenance Forms, Records, and Reports	0001 00
Major Components:	
Description and Location of	0002 00

N

Nomenclature:	
Cross-Reference	0001 00
Names, and Designations, Official.....	0001 00
Normal Operation, Stopping, and Starting	0005 00
Nuclear Decontamination Procedures	0006 00

O

Official Nomenclature, Names, and Designations	0001 00
Operating Procedures	0005 00
Operating the Carbon Monoxide Detector	0005 00
Operatng the Fresh Air Damper.....	0005 00
Operation:	
in Extreme Cold.....	0006 00
in Extreme Dust or Sand.....	0006 00
in High Winds	0006 00
in Rain or Extreme Humidity	0006 00
Principles of	0003 00
Under Unusual Conditions	0006 00
Under Usual Conditions	0005 00
Operator Control Box	0002 00, 0005 00
Operator Maintenance:	
Air Cleaner	0012 00
CO Detector – Operator Control Box	0013 00
Wheel Retraction Assembly	0014 00
Operator Preventive Maintenance Checks and Services (PMCS)	0010 00
Operator's Controls and Indicators,	
Use and Description of.....	0004 00

P

PMCS Procedures	0009 00, 0010 00, 0017 00, 001800
PMCS Table.....	0010 00, 0018 00
Plate:	
Identification	0005 00
Positioning Heater Outside Shelter	0005 00
Preparation:	
and Assembly for Use.....	0005 00
for Storage or Shipment.....	0069 00
for Movement	0005 00

Preservation	0069 00
Preventive Maintenance Checks and Services (PMCS)	
Operator	0010 00
Unit	0018 00
Principles of Operation	0003 00

Q

R

Records, and Reports, Maintenance Forms	0001 00
References	0089 00
Repair Parts and Special Tools List:	
Air Ducts	0110 00
Assembly, Engine System	0099 00
Battery Assembly	0106 00
Bulk Items	0112 00
Burner Assembly	0103 00
Burner Fuel Valve Assembly	0096 00
Burner Nozzle Assembly	0102 00
Cabinet Assembly	0093 00
Cabinet Assembly, Sheet Sound Installation	0094 00
Diesel Engine	0100 00
Duct Covers	0111 00
Fuel Panel Assembly	0095 00
Fuel Tank	0097 00
Heat Exchanger Transition Tube Assembly	0105 00
Heat System Assembly	0104 00
Ignition Assembly	0101 00
Inlet Fan Assembly	0098 00
Introduction	0092 00
Main Control Board Assembly	0108 00
National Stock Number Index	0113 00
NATO Slave Connector	0107 00
Operator Control Box Assembly	0109 00
Part Number Index	0114 00
Reporting Equipment Improvement Recommendations (EIR)	0001 00
Reports, Maintenance Forms, and Records	0001 00
Resetting the Heater	0004 00

S

Sand or Dust, Operation in Extreme	0006 00
Setup, Heater	0005 00
Shelter Requirements	0005 00
Shipment, Preparation for	0069 00
Shutdown Procedures	0005 00
Siting Requirements	0005 00
Starting, Normal Operation, and Stopping	0005 00
Stopping, Starting, and Normal Operation	0005 00
Storage:	
Administrative	0069 00
Preparation for	0069 00

Stowing:

Exhaust Stack	0005 00
External Fuel Supply	0005 00
Inlet and Outlet Duct Covers	0005 00
Flexible Inlet and Outlet Ducts	0005 00
Operator Control Box	0005 00
Wheel Chocks	0005 00

T

Troubleshooting, Operator	0007 00, 0008 00
Troubleshooting, Unit	0015 00, 0016 00
Troubleshooting, Direct Support	0070 00, 0071 00
Troubleshooting, General Support	0078 00, 0079 00

U

Unit Maintenance:

24V Alternator Assembly and Drive Belt.....	0039 00
Battery T-Bar.....	0059 00
Battery Terminal Connector	0057 00
Battery.....	0058 00
Burner Cone.....	0051 00
Burner Electrode and Nozzle Assembly	0050 00
Burner Fuel Pump Assembly	0033 00
Burner Fuel Valve Assembly 2-Way Solenoid Valve.....	0032 00
Burner Fuel Valve Assembly 3-Way Solenoid Valve.....	0031 00
Cabinet Assembly	0020 00
Carbon Monoxide Detector - Cabinet	0025 00
Carbon Monoxide Detector – Operator Control Box.....	0065 00
Combustion Blower.....	0049 00
Coupling Assembly	0040 00
Diesel Engine Air Cleaner.....	0042 00
Diesel Engine Electric Starter	0044 00
Diesel Engine Flywheel Housing and Cover	0045 00
Diesel Engine Fuel Injector Pump	0043 00
Diesel Engine Oil Fill Cap	0047 00
Diesel Engine Oil Filter Cleaning	0048 00
Diesel Engine Rocker Arm Assembly	0041 00
Door Latch	0023 00
Electrical Fuel Pump 3-Way Fuel Solenoid Valve	0029 00
Electrical Fuel Pump	0028 00
Engine Throttle Shutdown Solenoid	0026 00
External Fuel Hose Assembly.....	0068 00
External Fuel Supply Port	0036 00
Flame Sensor.....	0053 00
Fuel Filter	0027 00
Fuel Tank Level Switch.....	0035 00
Fuel Tank	0034 00
Heat Exchanger Exhaust Tube	0067 00
Heat Exchanger	0054 00
Ignition Assembly.....	0052 00
Inlet Fan Assembly	0038 00
Insulated Air Duct 16-in X 15-ft.....	0066 00
Introduction	0019 00

Jack Assembly	0022 00
Main Battery Power Switch	0030 00
Main Printed Circuit Board	0063 00
Mechanical Hour Meter	0064 00
Operator Box Mounting Bracket	0024 00
Operator Control Box Cable Assembly	0061 00
Outlet Temperature Sensor	0055 00
Relay Box Assembly	0062 00
Safety Screen	0037 00
Slave Receptacle	0060 00
Sound Sheet Installation	0021 00
Wire Harness Assemblies	0056 00
Unit Maintenance Preparation for Shipment and Storage	0069 00
Unit Preventive Maintenance Checks and Services (PMCS)	0017 00, 0018 00
Unusual Conditions, Operation Under	0006 00
Use and Description of Operator's Controls and Indicators	0004 00
Usual Conditions, Operation Under	0005 00

W

Winds, Operation in High	0006 00
Wheels, Lowering the Side	0005 00
Wheel Chocks, Deploying	0005 00

By Order of the Secretary of the Army:

Official:



JOYCE E. MORROW

*Administrative Assistant to the
Secretary of the Army*

0615701

PETER J. SCHOOMAKER
*General, United States Army
Chief of Staff*

DISTRIBUTION: To be distributed in accordance with initial distribution number (IDN) 256904, requirements for TM 9-4520-272-14&P.

These are the instructions for sending an electronic 2028

The following format must be used if submitting an electronic 2028. The subject line must be exactly the same and all fields must be included; however only the following fields are mandatory: 1, 3, 4, 5, 6, 7, 8, 9, 10, 13, 15, 16, 17, and 27.

From: "Whomever" <whomever@avma27.army.mil>

To: soldier.pubs@us.army.mil

Subject: DA Form 2028

1. From: Joe Smith
2. Unit: home
3. Address: 4300 Park
4. City: Hometown
5. St: MO
6. Zip: 77777
7. Date Sent: 19-OCT-93
8. Pub no: 55-2840-229-23
9. Pub Title: TM
10. Publication Date: 04-JUL-85
11. Change Number: 7
12. Submitter Rank: MSG
13. Submitter FName: Joe
14. Submitter MName: T
15. Submitter LName: Smith
16. Submitter Phone: 123-123-1234
17. Problem: 1
18. Page: 2
19. Paragraph: 3
20. Line: 4
21. NSN: 5
22. Reference: 6
23. Figure: 7
24. Table: 8
25. Item: 9
26. Total: 123
27. Text:

This is the text for the problem below line 27.

RECOMMENDED CHANGES TO PUBLICATIONS AND BLANK FORMS For use of this form, see AR 25-30; the proponent agency is ODISC4.						Use Part II (reverse) for Repair Parts and Special Tool Lists (RPSTL) and Supply Catalogs/Supply Manuals (SC/SM).	DATE 21 October 2003
TO: (Forward to proponent of publication or form) (Include ZIP Code) COMMANDER U.S ARMY TACOM-LIFE CYCLE MANAGEMENT COMMAND ATTN: AMSTA-LC-SECT 15 KANSAS STREET NATICK, MA 01760-5052						FROM: (Activity and location) (Include ZIP Code) <i>PFC Jane Doe</i> <i>CO A 3rd Engineer BR</i> <i>Ft. Leonardwood, MO 63108</i>	
PART I – ALL PUBLICATIONS (EXCEPT RPSTL AND SC/SM) AND BLANK FORMS							
PUBLICATION/FORM NUMBER TM 10-1670-296-23&P				DATE 30 October 2002	TITLE Unit Manual for Ancillary Equipment for Low Velocity Air Drop Systems		
ITEM NO.	PAGE NO.	PARA-GRAPH	LINE NO. *	FIGURE NO.	TABLE NO.	RECOMMENDED CHANGES AND REASON <i>(Provide exact wording of recommended changes, if possible).</i>	
	0036 00-2				1	<i>In table 1, Sewing Machine Code Symbols, the second sewing machine code symbol should be MD ZZ not MD 22.</i> <i>Change the manual to show Sewing Machine, Industrial: Zig-Zag; 308 stitch; medium-duty; NSN 3530-01-181-1421 as a MD ZZ code symbol.</i>	
<i>*Reference to line numbers within the paragraph or subparagraph.</i>							
TYPED NAME, GRADE OR TITLE Jane Doe, PFC				TELEPHONE EXCHANGE/AUTOVON, PLUS EXTENSION 508-233-4141		SIGNATURE Jane Doe <i>Jane Doe</i>	

TO: <i>(Forward direct to addressee listed in publication)</i> COMMANDER U.S ARMY TACOM-LIFE CYCLE MANAGEMENT COMMAND ATTN: AMSTA-LC-SECT 15 KANSAS STREET NATICK, MA 01760-5052	FROM: <i>(Activity and location) (Include ZIP Code)</i> <i>PFC Jane Doe</i> <i>CO A 3rd Engineer BR</i> <i>Ft. Leonardwood, MO 63108</i>	DATE 21 October 2003
--	---	--------------------------------

PART II – REPAIR PARTS AND SPECIAL TOOL LISTS AND SUPPLY CATALOGS/SUPPLY MANUALS

PUBLICATION NUMBER TM 10-1670-296-23&P	DATE 30 October 2002	TITLE Unit Manual for Ancillary Equipment for Low Velocity Air Drop Systems
--	--------------------------------	---

PAGE NO.	COLM NO.	LINE NO.	NATIONAL STOCK NUMBER	REFERENCE NO.	FIGURE NO.	ITEM NO.	TOTAL NO. OF MAJOR ITEMS SUPPORTED	RECOMMENDED ACTION
0066 00-1					4			<i>Callout 16 in figure 4 is pointed to a <u>D-Ring</u>. In the Repair Parts List key for figure 4, item 16 is called a <u>Snap Hook</u>. Please correct one or the other.</i>

SAMPLE

PART III – REMARKS *(Any general remarks or recommendations, or suggestions for improvement of publications and blank forms. Additional blank sheets may be used if more space is needed.)*

TYPED NAME, GRADE OR TITLE	TELEPHONE EXCHANGE/AUTOVON, PLUS EXTENSION	SIGNATURE
----------------------------	--	-----------

RECOMMENDED CHANGES TO PUBLICATIONS AND BLANK FORMS						Use Part II (reverse) for Repair Parts and Special Tool Lists (RPSTL) and Supply Catalogs/Supply Manuals (SC/SM).	DATE
For use of this form, see AR 25-30; the proponent agency is ODISC4.							
TO: (Forward to proponent of publication or form) (Include ZIP Code) COMMANDER U.S. ARMY TACOM LIFE CYCLE MANAGEMENT COMMAND ATTN: AMSTA-LC-SECT 15 KANSAS STREET NATICK, MA 01760-5052						FROM: (Activity and location) (Include ZIP Code)	
PART I – ALL PUBLICATIONS (EXCEPT RPSTL AND SC/SM) AND BLANK FORMS							
PUBLICATION/FORM NUMBER TM 9-4520-272-14&P				DATE 1 June 2006		TITLE Large Capacity Field Heater (LCFH)	
ITEM NO.	PAGE NO.	PARA-GRAPH	LINE NO. *	FIGURE NO.	TABLE NO.	RECOMMENDED CHANGES AND REASON (Provide exact wording of recommended changes, if possible).	
*Reference to line numbers within the paragraph or subparagraph.							
TYPED NAME, GRADE OR TITLE				TELEPHONE EXCHANGE/AUTOVON, PLUS EXTENSION		SIGNATURE	

TO: <i>(Forward direct to addressee listed in publication)</i> COMMANDER U.S. ARMY TACOM LIFE CYCLE MANAGEMENT COMMAND ATTN: AMSTA-LC-SECT 15 KANSAS STREET NATICK, MA 01760-5052	FROM: <i>(Activity and location) (Include ZIP Code)</i>	DATE
--	--	-------------

PART II – REPAIR PARTS AND SPECIAL TOOL LISTS AND SUPPLY CATALOGS/SUPPLY MANUALS

PUBLICATION NUMBER TM 9-4520-272-14&P					DATE 1 June 2006			TITLE Large Capacity Field Heater (LCFH)
PAGE NO.	COLM NO.	LINE NO.	NATIONAL STOCK NUMBER	REFERENCE NO.	FIGURE NO.	ITEM NO.	TOTAL NO. OF MAJOR ITEMS SUPPORTED	RECOMMENDED ACTION

PART III – REMARKS *(Any general remarks or recommendations, or suggestions for improvement of publications and blank forms. Additional blank sheets may be used if more space is needed.)*

TYPED NAME, GRADE OR TITLE	TELEPHONE EXCHANGE/AUTOVON, PLUS EXTENSION	SIGNATURE
----------------------------	--	-----------

RECOMMENDED CHANGES TO PUBLICATIONS AND BLANK FORMS						Use Part II (reverse) for Repair Parts and Special Tool Lists (RPSTL) and Supply Catalogs/Supply Manuals (SC/SM).	DATE
For use of this form, see AR 25-30; the proponent agency is ODISC4.							
TO: (Forward to proponent of publication or form) (Include ZIP Code) COMMANDER U.S. ARMY TACOM LIFE CYCLE MANAGEMENT COMMAND ATTN: AMSTA-LC-SECT 15 KANSAS STREET NATICK, MA 01760-5052						FROM: (Activity and location) (Include ZIP Code)	
PART I – ALL PUBLICATIONS (EXCEPT RPSTL AND SC/SM) AND BLANK FORMS							
PUBLICATION/FORM NUMBER				DATE		TITLE	
TM 9-4520-272-14&P				1 June 2006		Large Capacity Field Heater (LCFH)	
ITEM NO.	PAGE NO.	PARA-GRAPH	LINE NO. *	FIGURE NO.	TABLE NO.	RECOMMENDED CHANGES AND REASON <i>(Provide exact wording of recommended changes, if possible).</i>	
<i>*Reference to line numbers within the paragraph or subparagraph.</i>							
TYPED NAME, GRADE OR TITLE				TELEPHONE EXCHANGE/AUTOVON, PLUS EXTENSION		SIGNATURE	

TO: <i>(Forward direct to addressee listed in publication)</i> COMMANDER U.S. ARMY TACOM LIFE CYCLE MANAGEMENT COMMAND ATTN: AMSTA-LC-SECT 15 KANSAS STREET NATICK, MA 01760-5052	FROM: <i>(Activity and location) (Include ZIP Code)</i>	DATE
--	--	-------------

PART II – REPAIR PARTS AND SPECIAL TOOL LISTS AND SUPPLY CATALOGS/SUPPLY MANUALS

PUBLICATION NUMBER TM 9-4520-272-14&P					DATE 1 June 2006			TITLE Large Capacity Field Heater (LCFH)	
PAGE NO.	COLM NO.	LINE NO.	NATIONAL STOCK NUMBER	REFERENCE NO.	FIGURE NO.	ITEM NO.	TOTAL NO. OF MAJOR ITEMS SUPPORTED	RECOMMENDED ACTION	

PART III – REMARKS *(Any general remarks or recommendations, or suggestions for improvement of publications and blank forms. Additional blank sheets may be used if more space is needed.)*

TYPED NAME, GRADE OR TITLE	TELEPHONE EXCHANGE/AUTOVON, PLUS EXTENSION	SIGNATURE

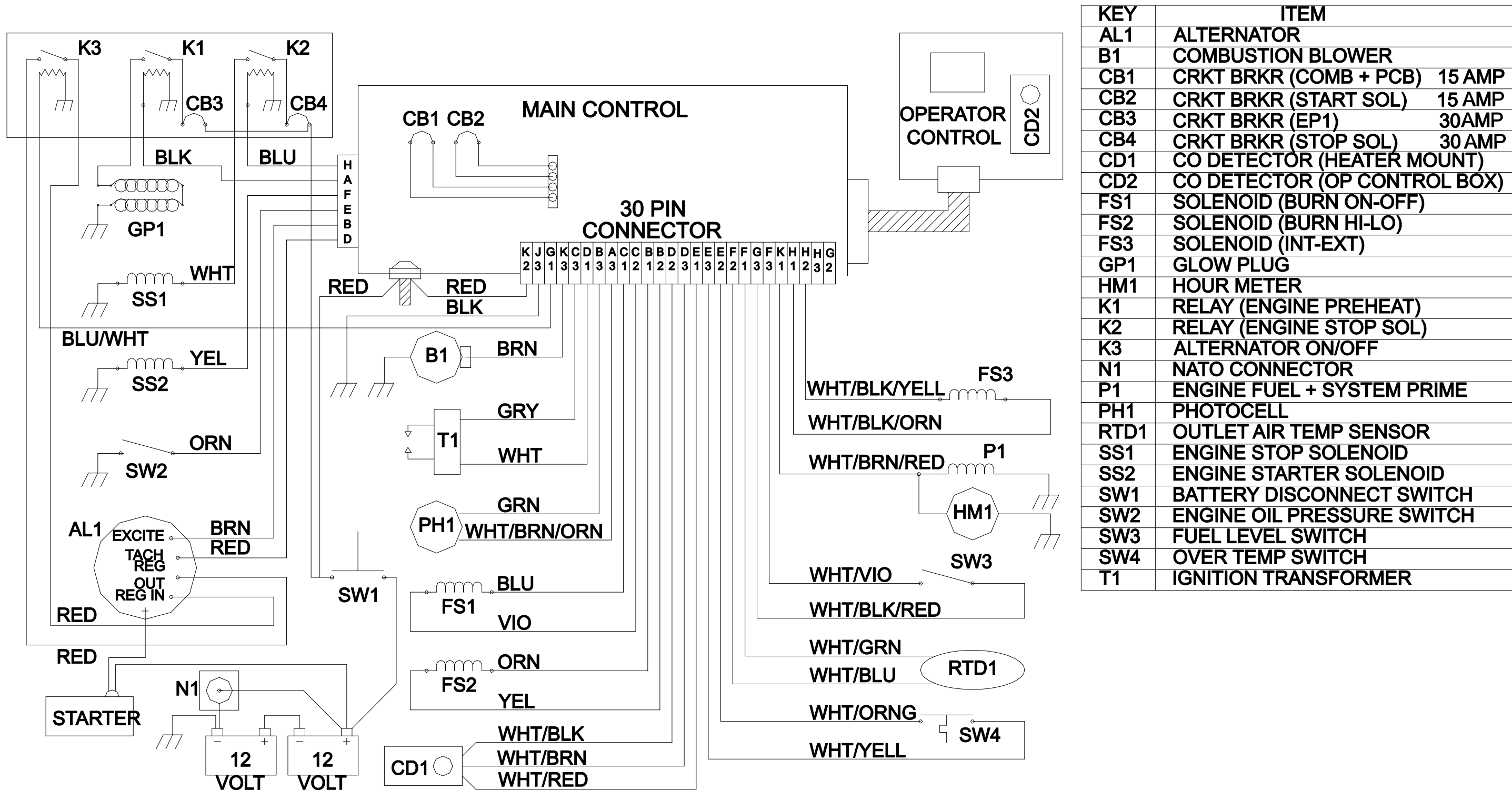

KEY	ITEM
AL1	ALTERNATOR
B1	COMBUSTION BLOWER
CB1	CRKT BRKR (COMB + PCB) 15 AMP
CB2	CRKT BRKR (START SOL) 15 AMP
CB3	CRKT BRKR (EP1) 30AMP
CB4	CRKT BRKR (STOP SOL) 30 AMP
CD1	CO DETECTOR (HEATER MOUNT)
CD2	CO DETECTOR (OP CONTROL BOX)
FS1	SOLENOID (BURN ON-OFF)
FS2	SOLENOID (BURN HI-LO)
FS3	SOLENOID (INT-EXT)
GP1	GLOW PLUG
HM1	HOUR METER
K1	RELAY (ENGINE PREHEAT)
K2	RELAY (ENGINE STOP SOL)
K3	ALTERNATOR ON/OFF
N1	NATO CONNECTOR
P1	ENGINE FUEL + SYSTEM PRIME
PH1	PHOTOCELL
RTD1	OUTLET AIR TEMP SENSOR
SS1	ENGINE STOP SOLENOID
SS2	ENGINE STARTER SOLENOID
SW1	BATTERY DISCONNECT SWITCH
SW2	ENGINE OIL PRESSURE SWITCH
SW3	FUEL LEVEL SWITCH
SW4	OVER TEMP SWITCH
T1	IGNITION TRANSFORMER

FO 1. LCFH Wiring Diagram

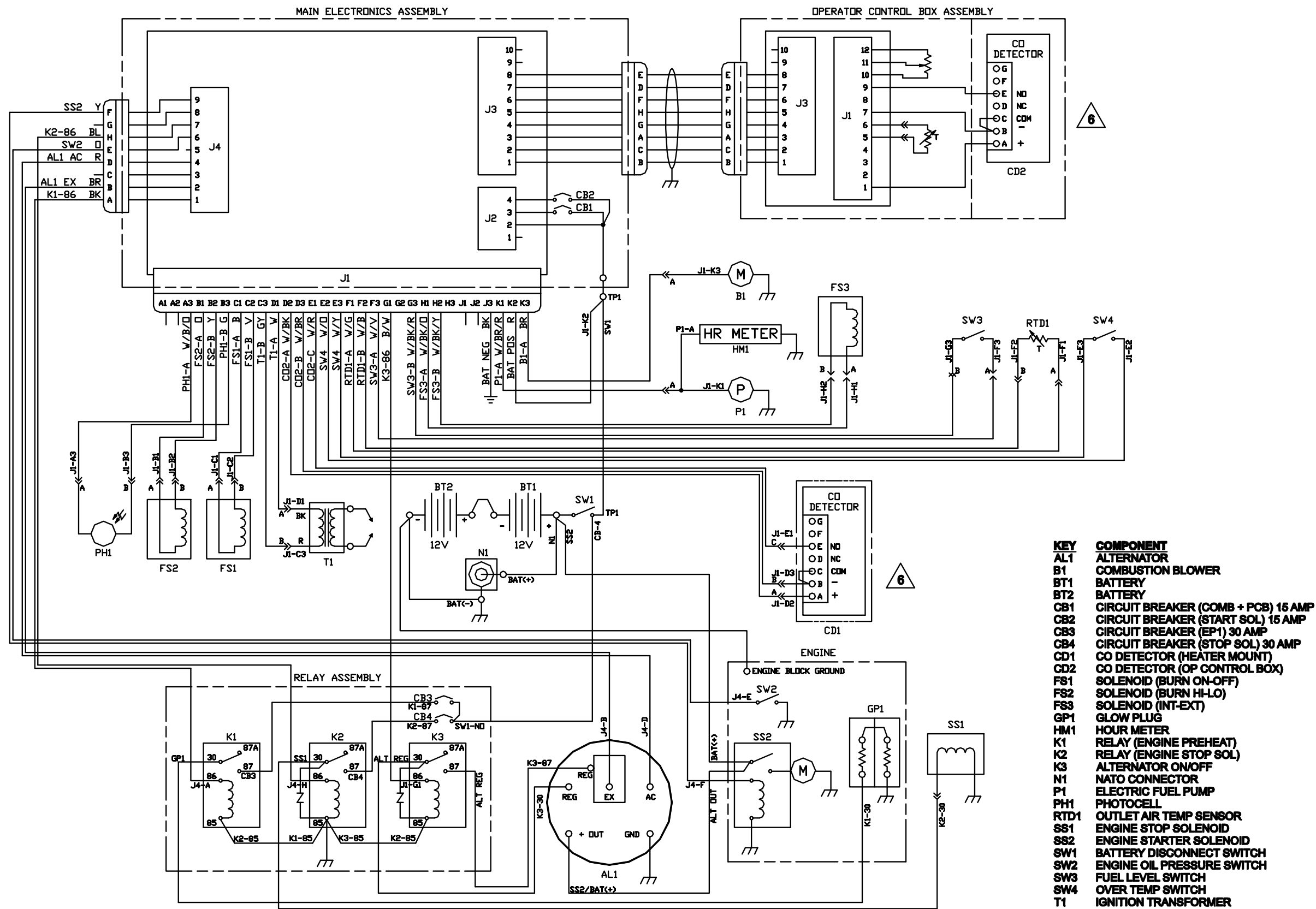

- | KEY | COMPONENT |
|------|-------------------------------------|
| AL1 | ALTERNATOR |
| B1 | COMBUSTION BLOWER |
| BT1 | BATTERY |
| BT2 | BATTERY |
| CB1 | CIRCUIT BREAKER (COMB + PCB) 15 AMP |
| CB2 | CIRCUIT BREAKER (START SOL) 15 AMP |
| CB3 | CIRCUIT BREAKER (EP1) 30 AMP |
| CB4 | CIRCUIT BREAKER (STOP SOL) 30 AMP |
| CD1 | CO DETECTOR (HEATER MOUNT) |
| CD2 | CO DETECTOR (OP CONTROL BOX) |
| FS1 | SOLENOID (BURN ON-OFF) |
| FS2 | SOLENOID (BURN HI-LO) |
| FS3 | SOLENOID (INT-EXT) |
| GP1 | GLOW PLUG |
| HM1 | HOUR METER |
| K1 | RELAY (ENGINE PREHEAT) |
| K2 | RELAY (ENGINE STOP SOL) |
| K3 | ALTERNATOR ON/OFF |
| N1 | NATO CONNECTOR |
| P1 | ELECTRIC FUEL PUMP |
| PH1 | PHOTOCELL |
| RTD1 | OUTLET AIR TEMP SENSOR |
| SS1 | ENGINE STOP SOLENOID |
| SS2 | ENGINE STARTER SOLENOID |
| SW1 | BATTERY DISCONNECT SWITCH |
| SW2 | ENGINE OIL PRESSURE SWITCH |
| SW3 | FUEL LEVEL SWITCH |
| SW4 | OVER TEMP SWITCH |
| T1 | IGNITION TRANSFORMER |

FO 2. LCFH Wiring Schematic

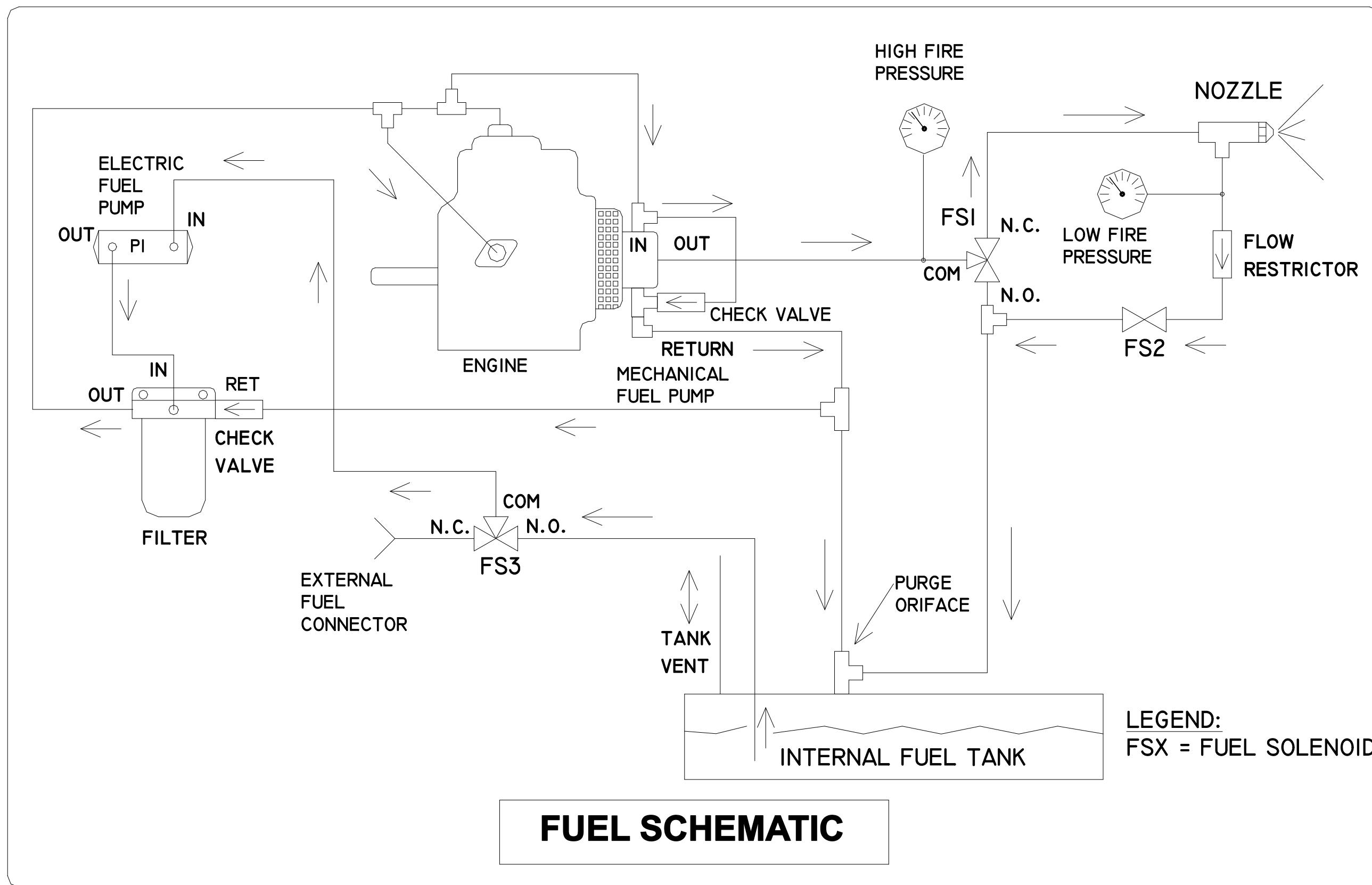

FO 3. LCFH Fuel System Schematic Diagram

NOTICE: THIS DRAWING IS AND REPRESENTS A PROPRIETARY DESIGN OF THE HUNTER MANUFACTURING COMPANY AND WITHOUT PROFIT IS RELEASED AND LICENSED FOR LIMITED PREPRODUCTION SOLELY FOR THE PURPOSE OF FURNISHING INFORMATION FOR EVALUATING, TESTING AND INSTALLING THE ITEM SHOWN. ALL RIGHTS ARE RESERVED AND ALL OTHER USES AND REPRODUCTION FOR ANY OTHER PURPOSE ARE PROHIBITED.

REVISIONS			
NO	DESCRIPTION	DATE	CHANGE DOC
1	ORIGINAL RELEASE - AS BUILT PROTO 01-10 - ECP 1546	8/21/03	6587

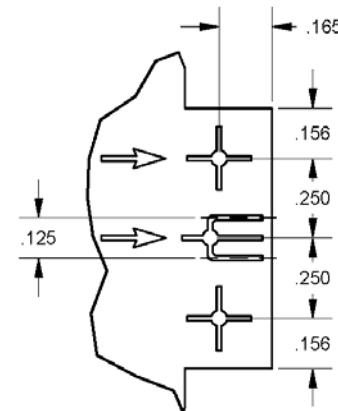
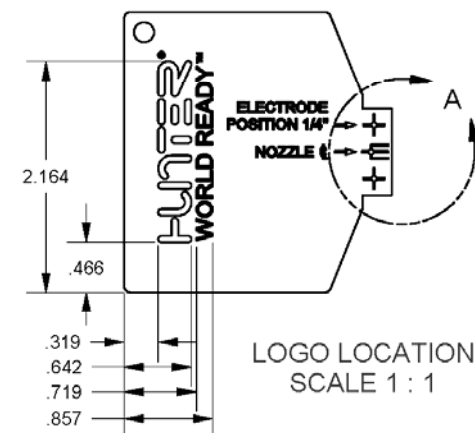
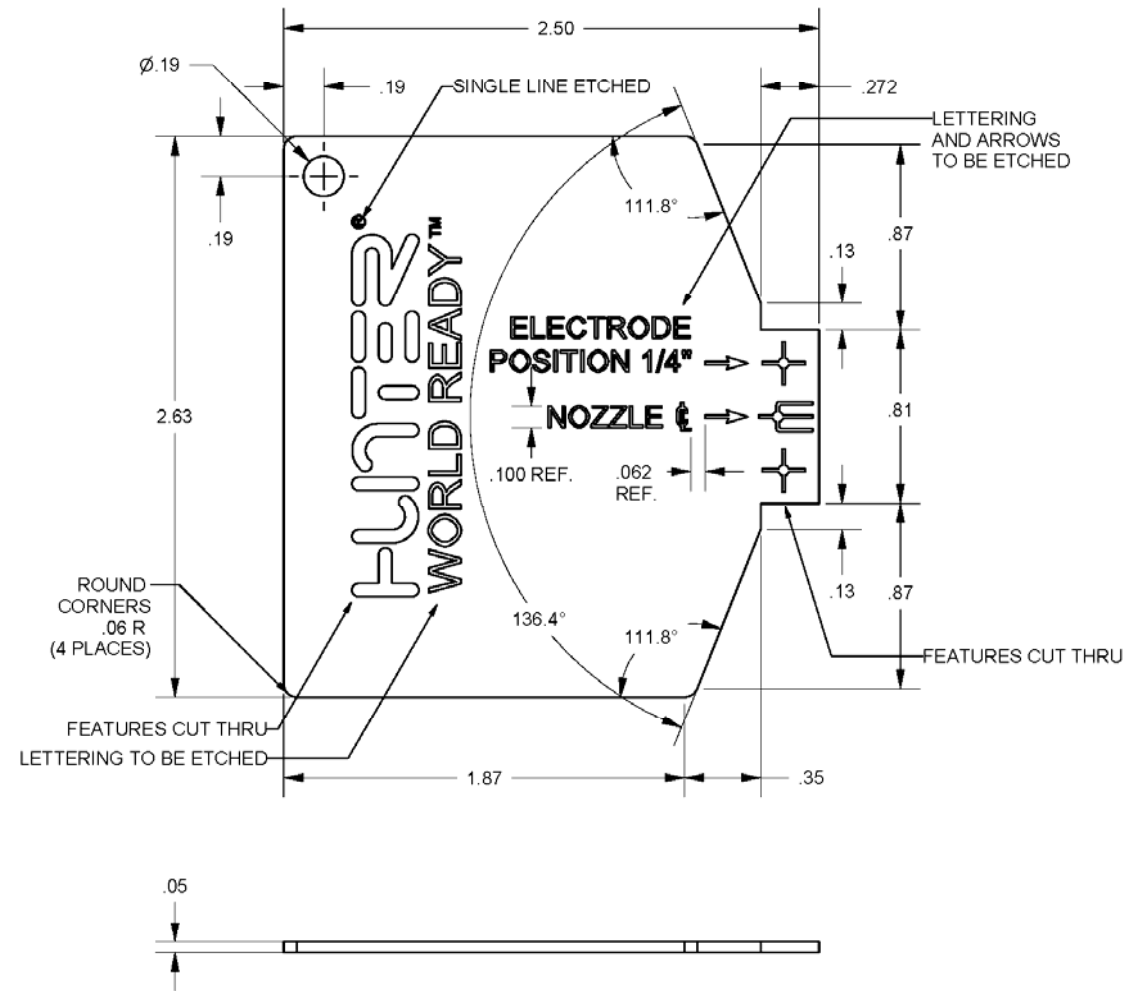

40791 1

NOTES:
1. MATERIAL: 18ga 310 STAINLESS STEEL

TOLERANCES ALL DIMENSIONS EXCEPT WHERE OTHERWISE SPECIFIED			CONTRACT NO. DAAB15-02-C-0019		
FRACTS ± 1/64"	DECIMALS 30X ± 0.10" 100X ± 0.05"	ANGLES ± 1.0°	Hunter Manufacturing Company 30525 Aurora Road Cleveland, OH 44139		
DR ekelley	DATE 8/21/2003	RELEASED			
NEXT ASSY:			TITLE: LARGE CAPACITY FIELD HEATER ELECTRODE SETTING TOOL		
HMC CODE IDENT. NO. 40790		DRAWING NO. 92878	DRAWING NO. 40791	REV. 1	SCALE 2:1
SHEET 1 OF 1			SHEET 1 OF 1		

FO 3. LCFH Electrode Alignment Tool

